

TOSHIBA

FILE NO. 810-200709GR

REVISED: 01

CIRCUIT DIAGRAMS



COMBINATION FLAT COLOR TELEVISION AND VIDEO CASSETTE RECORDER/ DVD VIDEO PLAYER

MW20H63

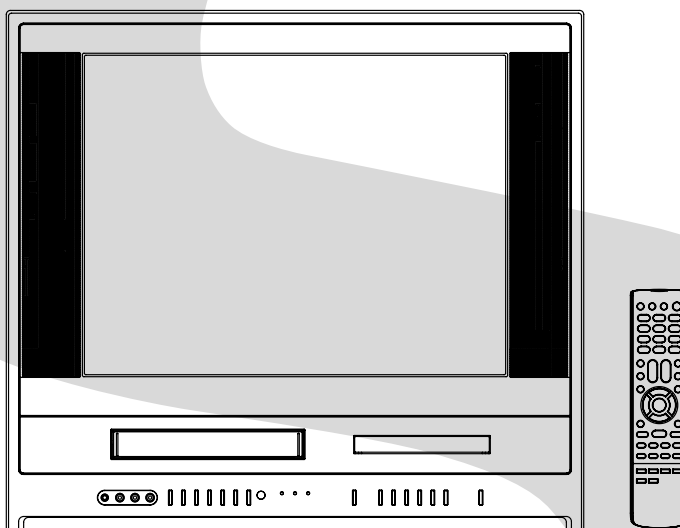

The above model is classified as a green product (*1), as indicated by the underlined serial number. This Service Manual describes replacement parts for the green product. When repairing this green product, use the part(s) described in this manual and lead-free solder (*2).

For (*1) and (*2), see the next page.

DVD BLOCK DIAGRAM

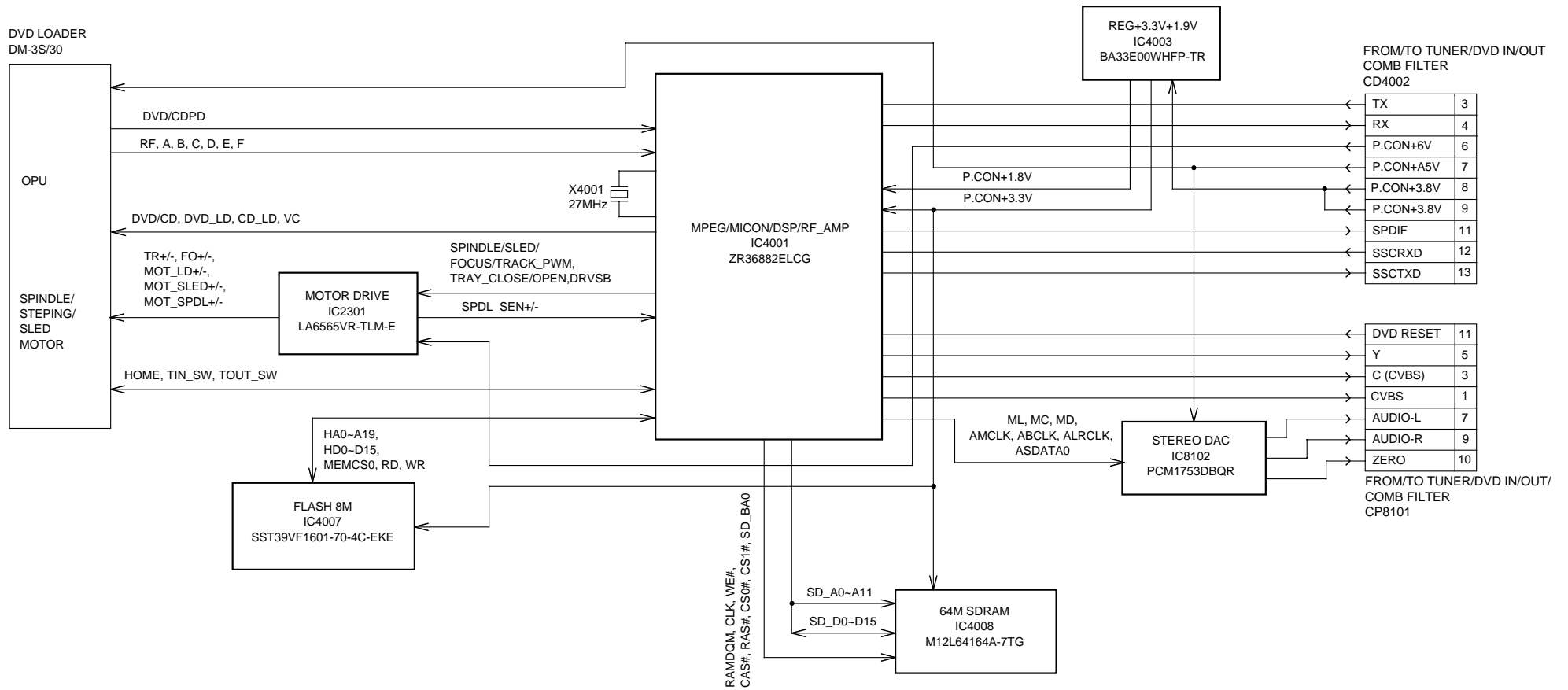

DIGITAL MODULE BLOCK DIAGRAM

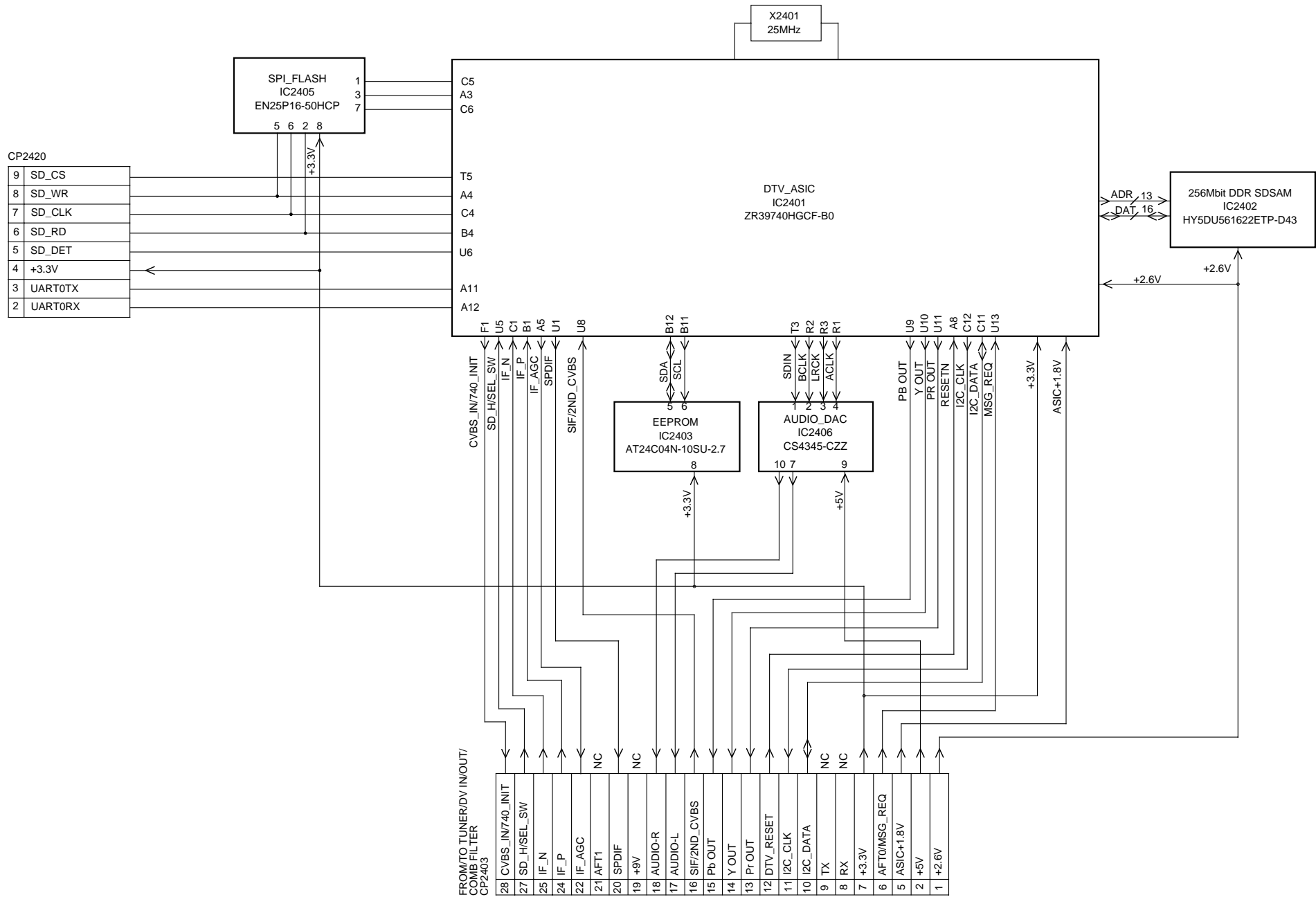

Y/C/AUDIO/HEAD AMP BLOCK DIAGRAM

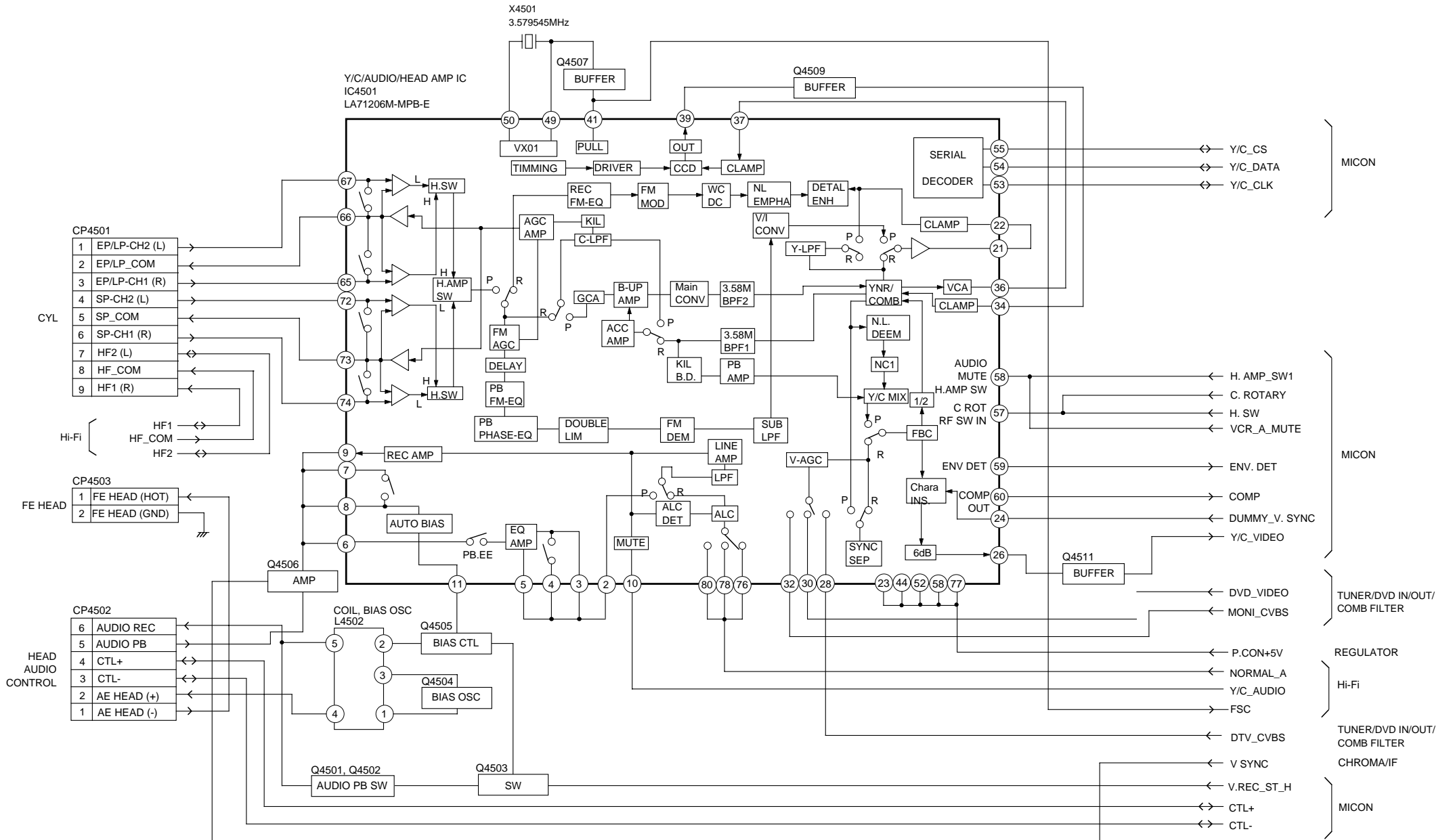

MICON BLOCK DIAGRAM

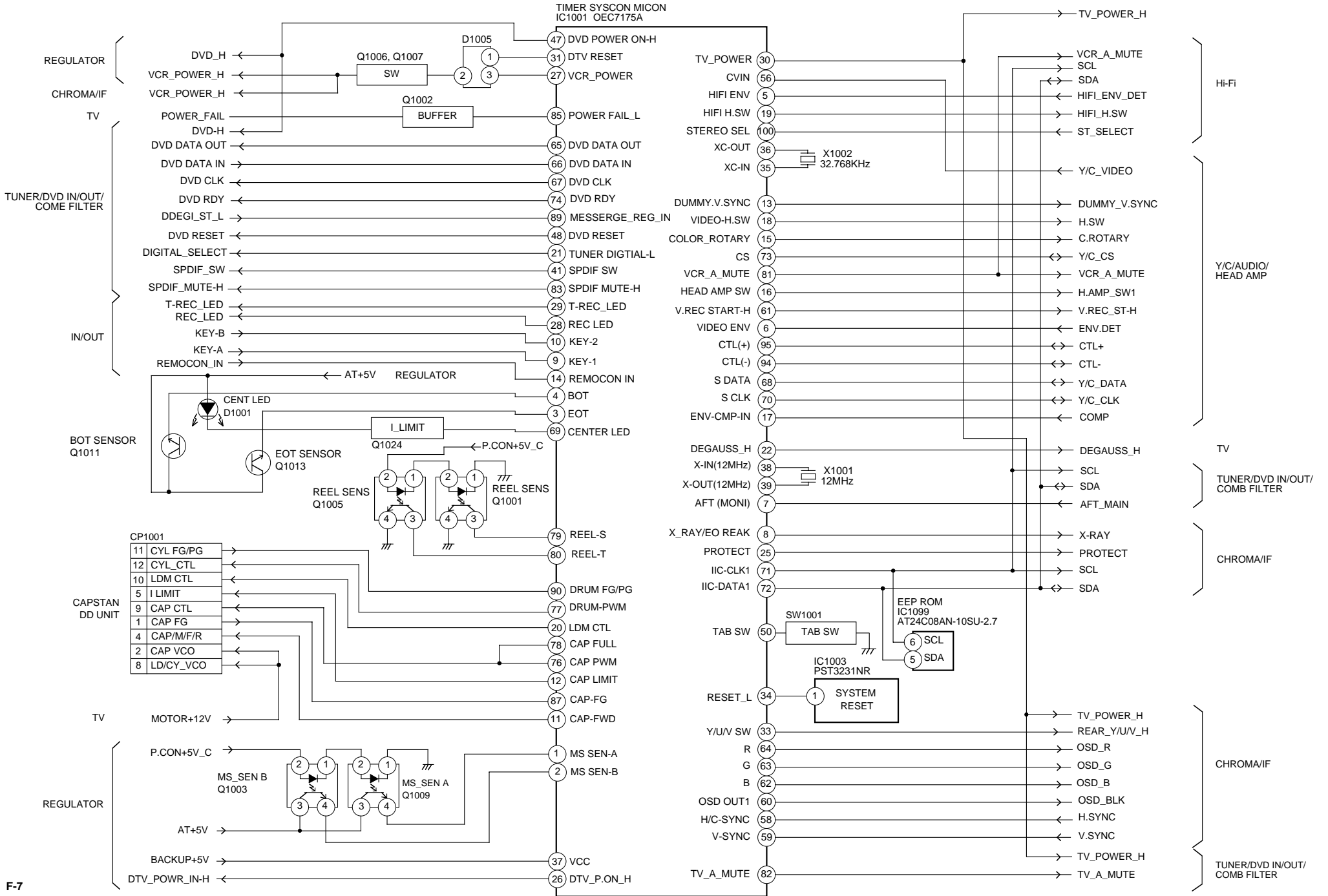

IN/OUT BLOCK DIAGRAM

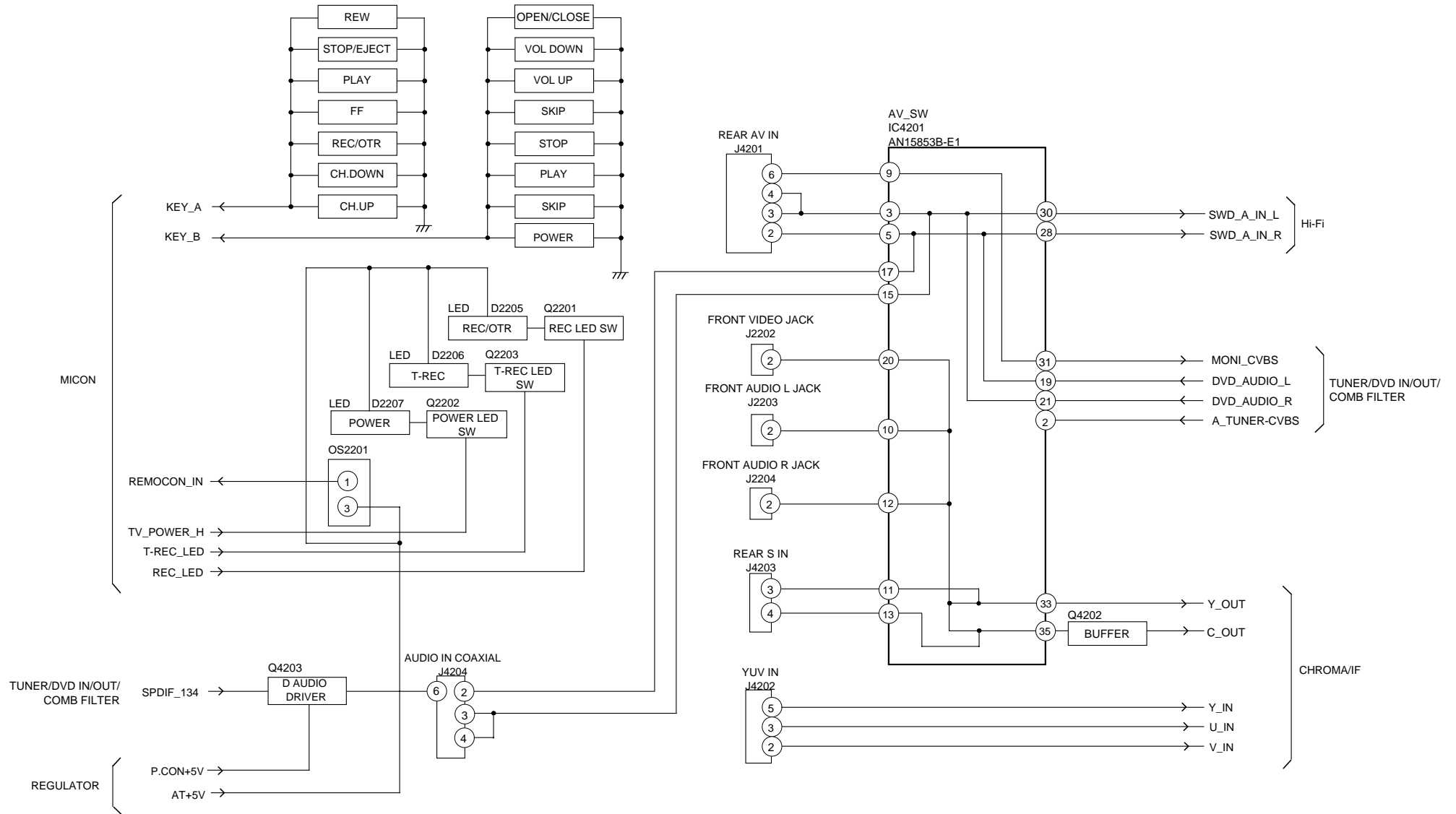

CHROMA/IF BLOCK DIAGRAM

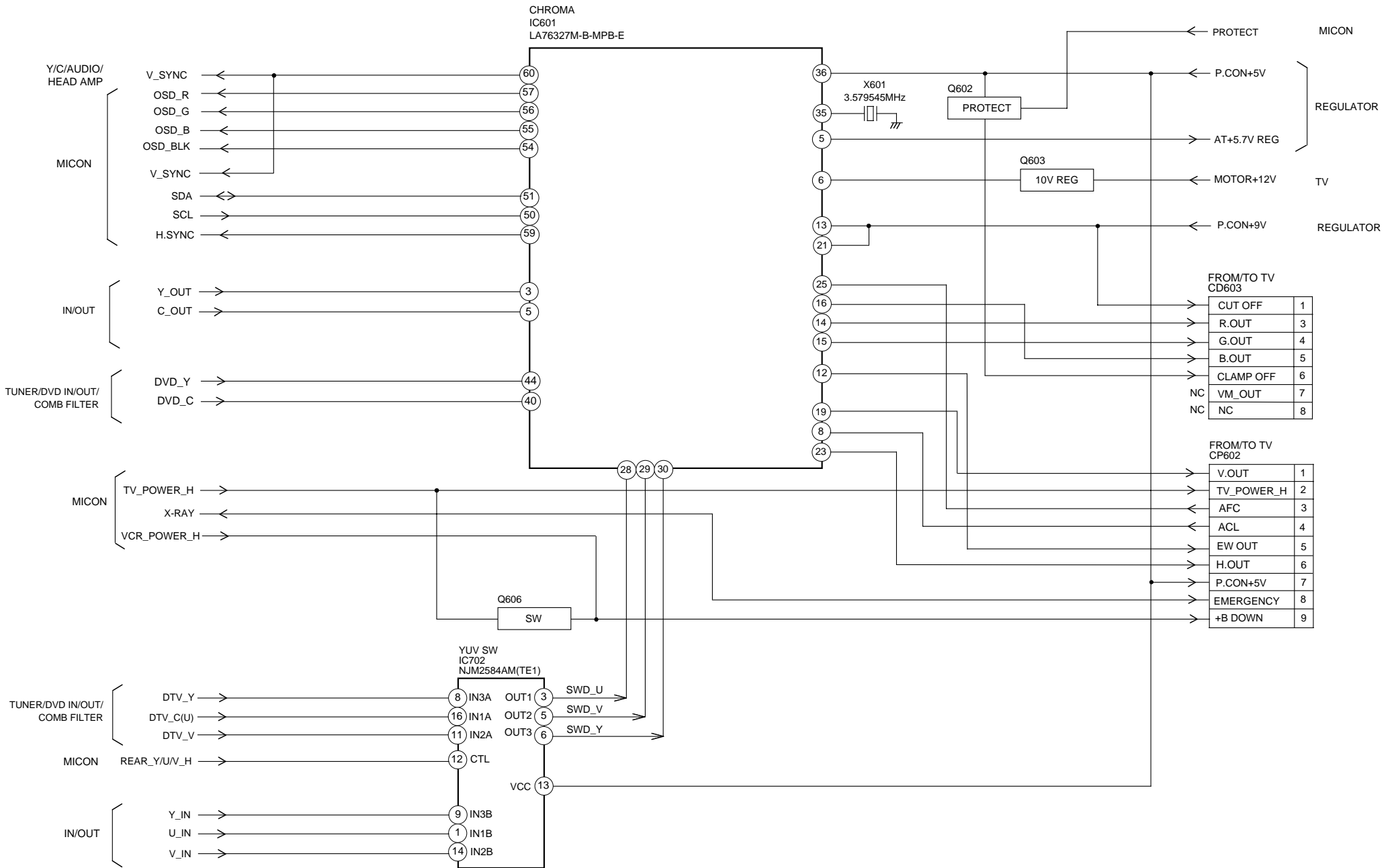

SOUND AMP/SURROUND BLOCK DIAGRAM

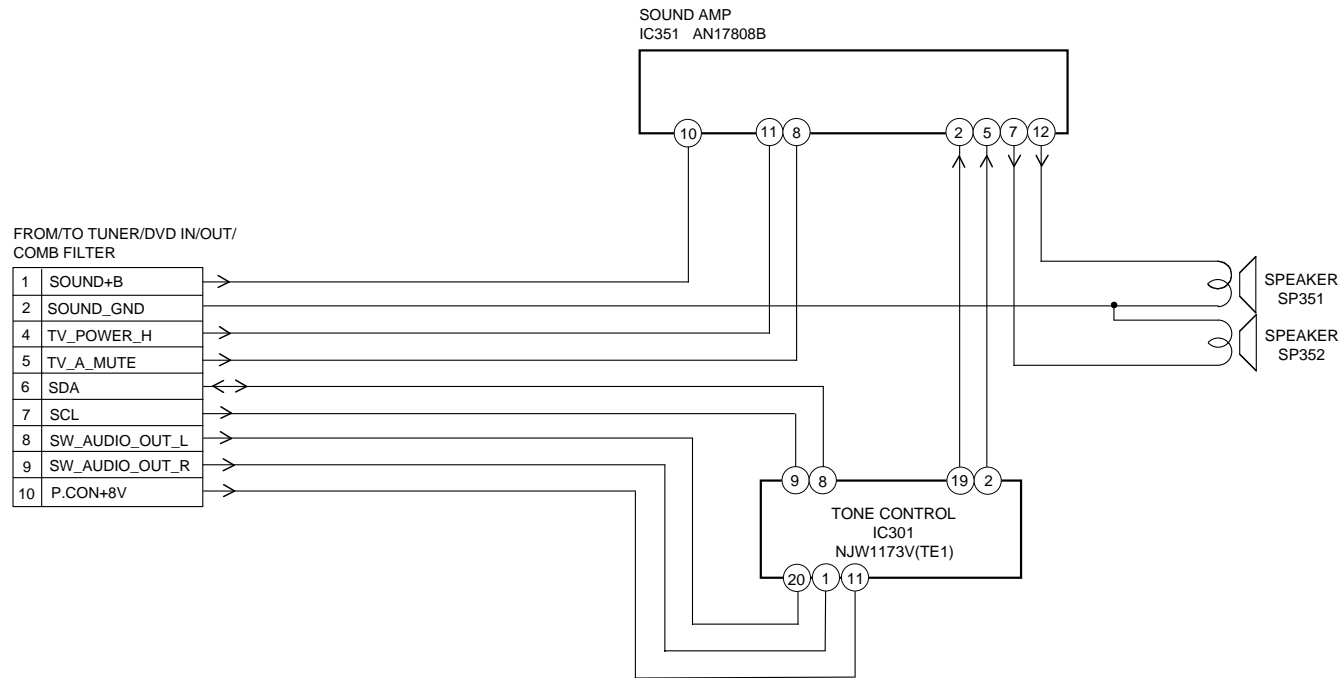

Hi-Fi/DEMODULATOR BLOCK DIAGRAM

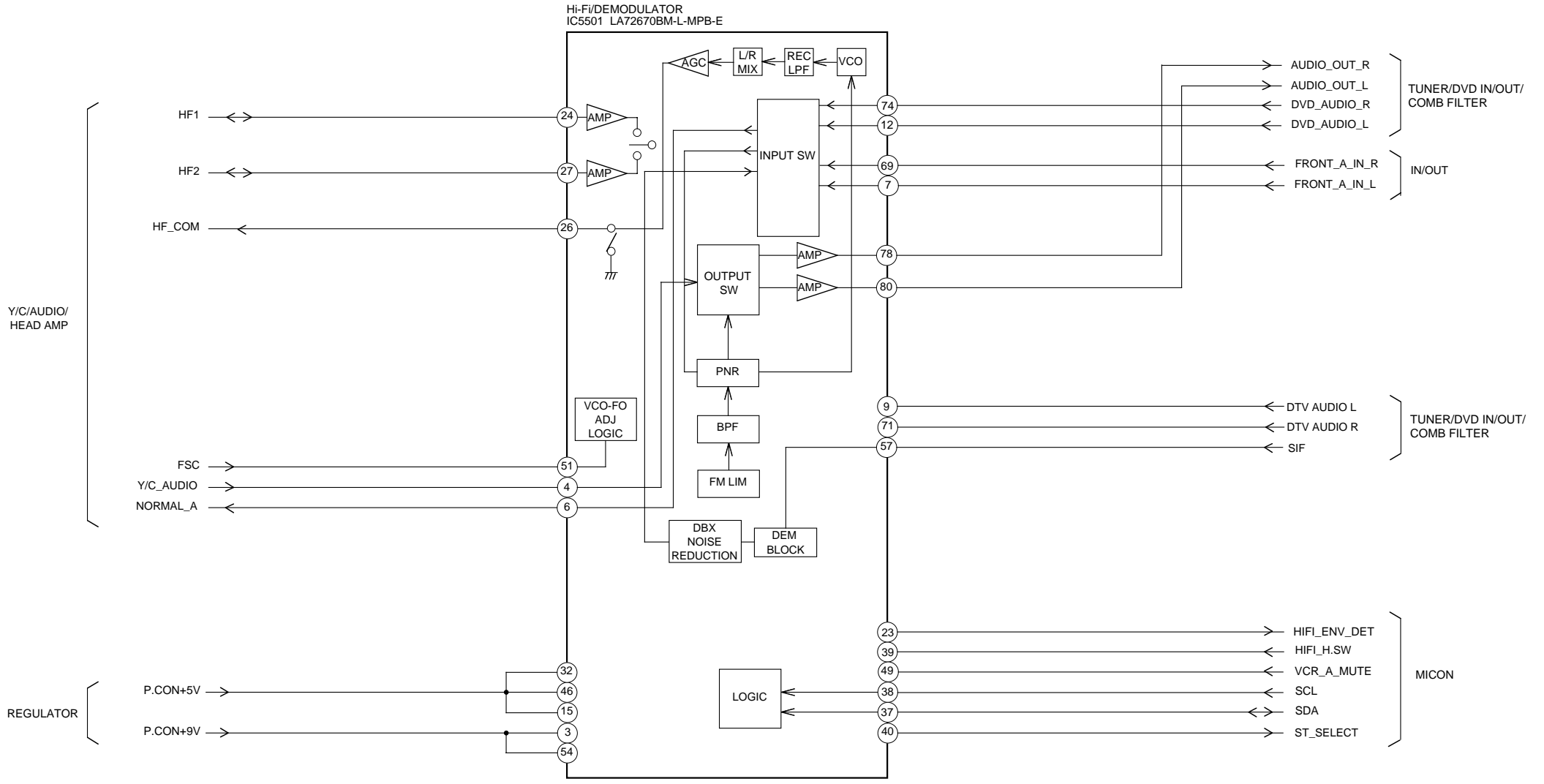

TUNER/DVD IN/OUT/COMB FILTER BLOCK DIAGRAM

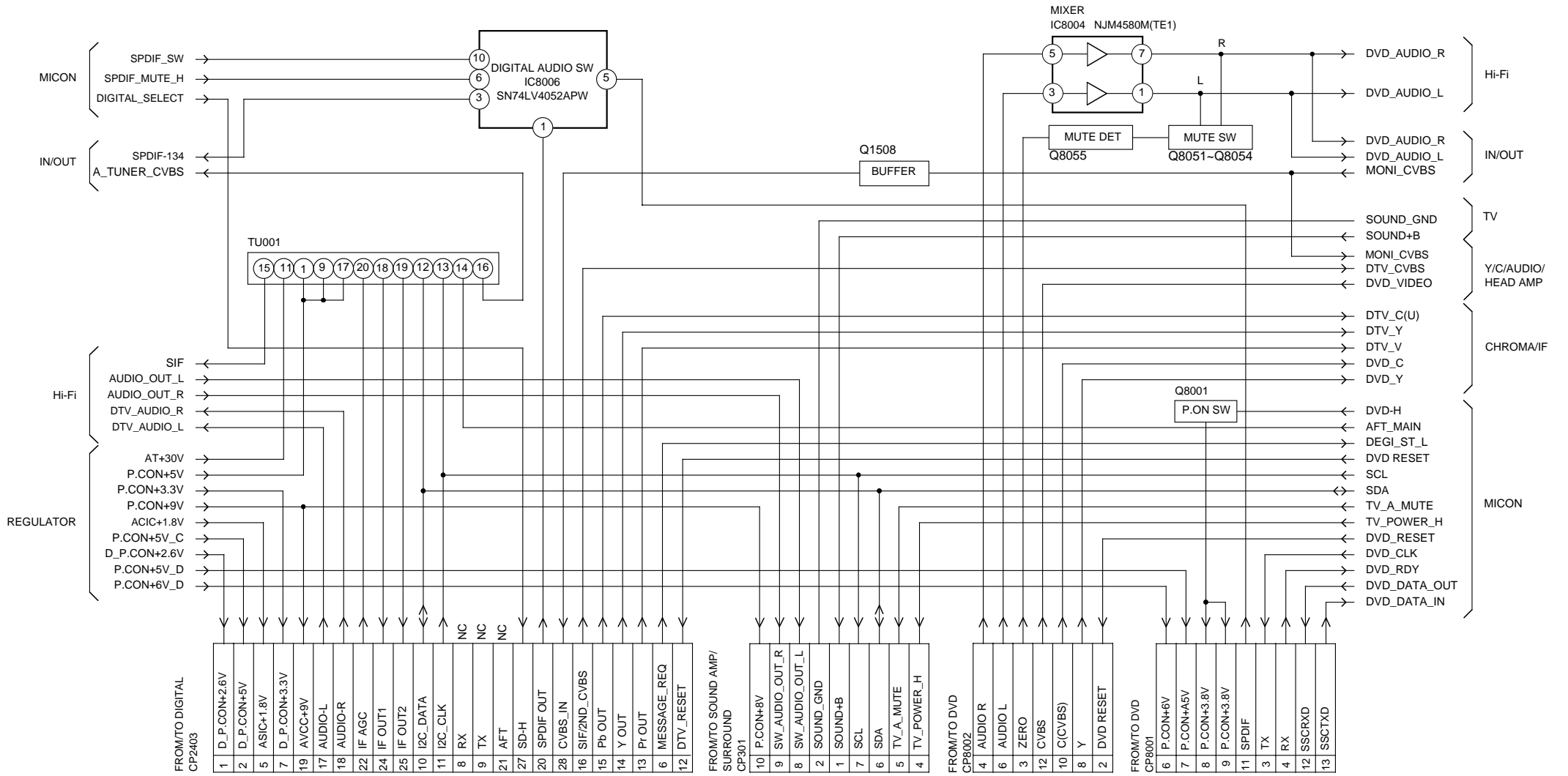

REGULATOR BLOCK DIAGRAM

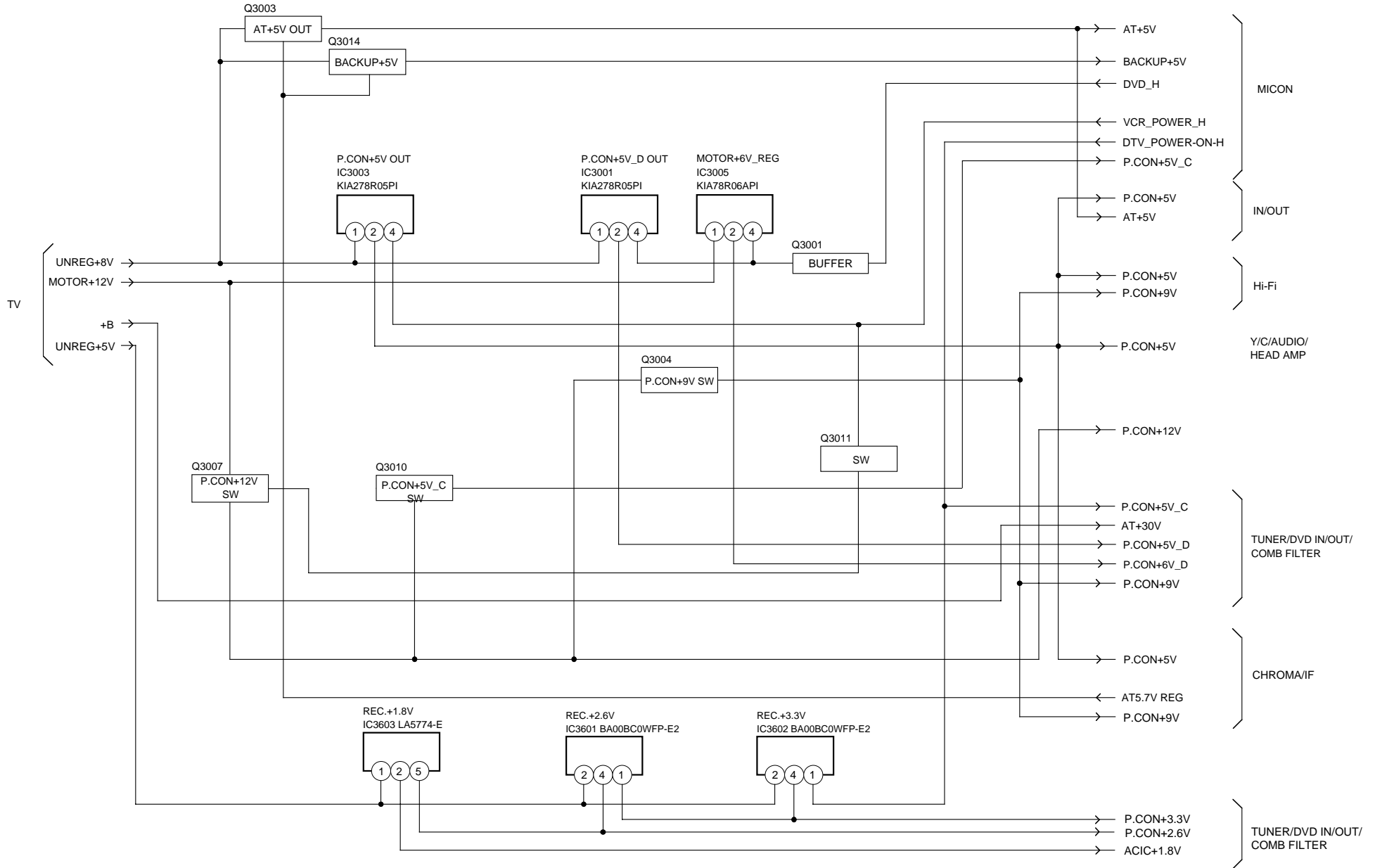

TV BLOCK DIAGRAM

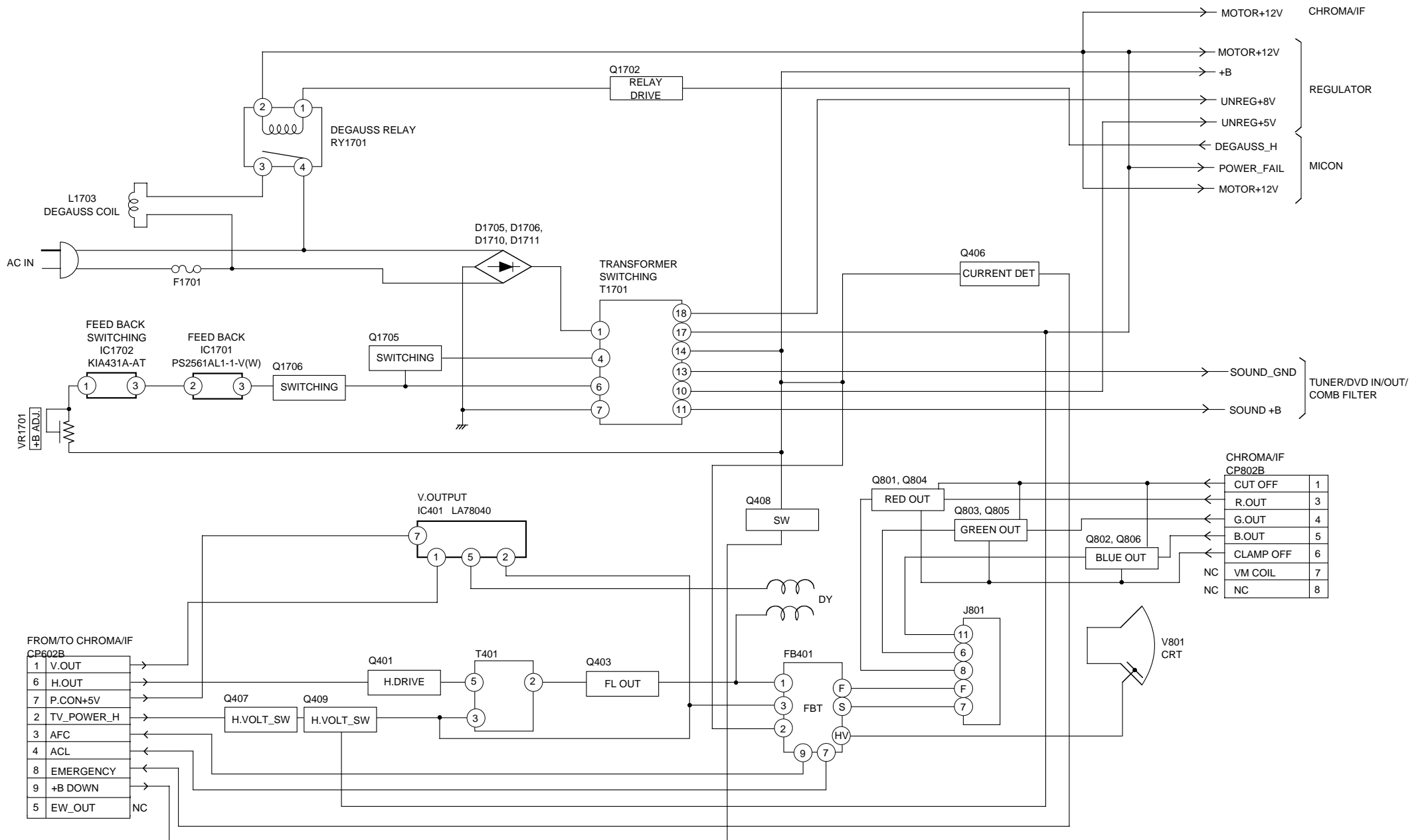

- MOTOR+12V CHROMA/IF
- MOTOR+12V
- +B REGULATOR
- UNREG+8V
- UNREG+5V
- DEGAUSS_H MICON
- POWER_FAIL
- MOTOR+12V

- SOUND_GND TUNER/DVD IN/OUT/ COMB FILTER
- SOUND +B

CHROMA/IF	
CP802B	
CUT OFF	1
R.OUT	3
G.OUT	4
B.OUT	5
CLAMP OFF	6
NC	7
NC	8

FROM/TO	CHROMA/IF
CP602B	
1	V.OUT
6	H.OUT
7	P.CON+5V
2	TV_POWER_H
3	AFC
4	ACL
8	EMERGENCY
9	+B DOWN
5	EW_OUT
	NC

**PRINTED CIRCUIT BOARDS
VCR MT (INSERTED PARTS)
SOLDER SIDE**

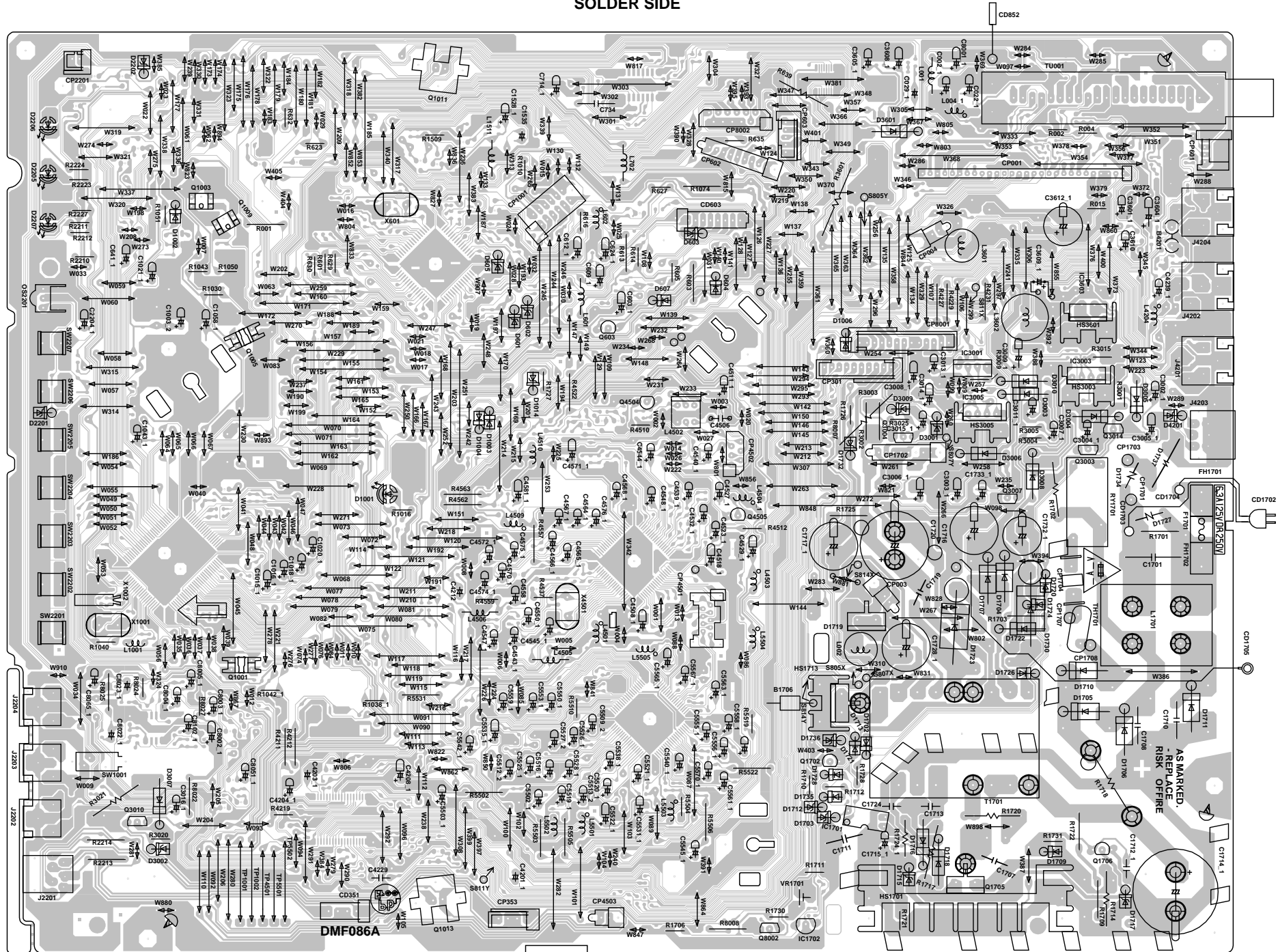

PRINTED CIRCUIT BOARDS
VCR MT (CHIP MOUNTED PARTS)
SOLDER SIDE



PRINTED CIRCUIT BOARDS

DIGITAL (TOP SIDE)

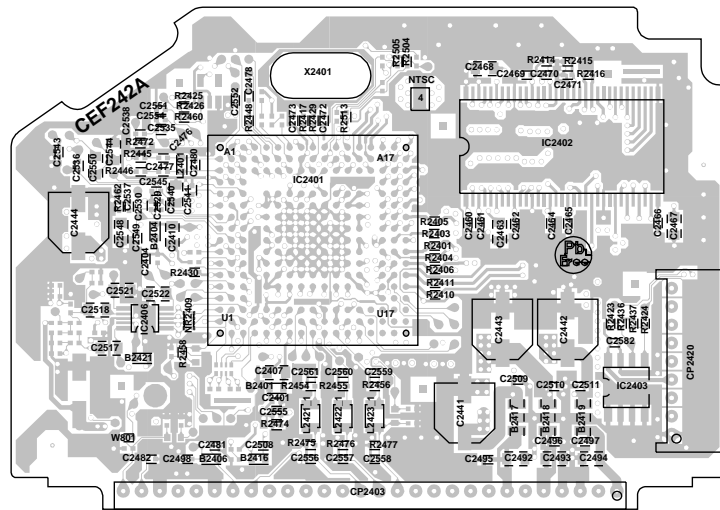

DIGITAL (BOTTOM SIDE)

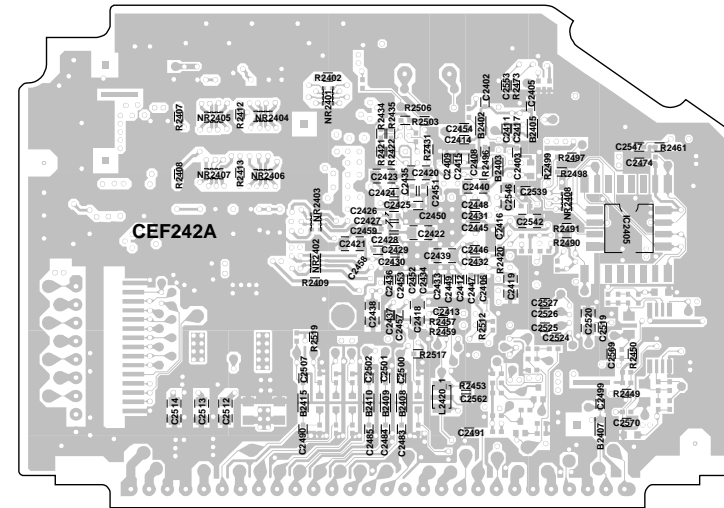

PRINTED CIRCUIT BOARDS

LOADING MOTOR (INSERTED PARTS) SOLDER SIDE

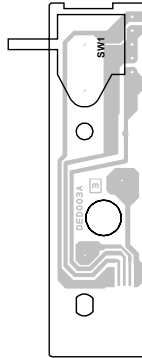

LOADING MOTOR (CHIP MOUNTED PARTS) SOLDER SIDE

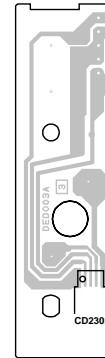

SW SOLDER SIDE

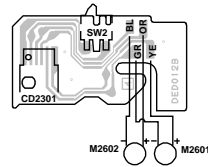

MEMORY SCHEMATIC DIAGRAM

(DVD MT PCB)

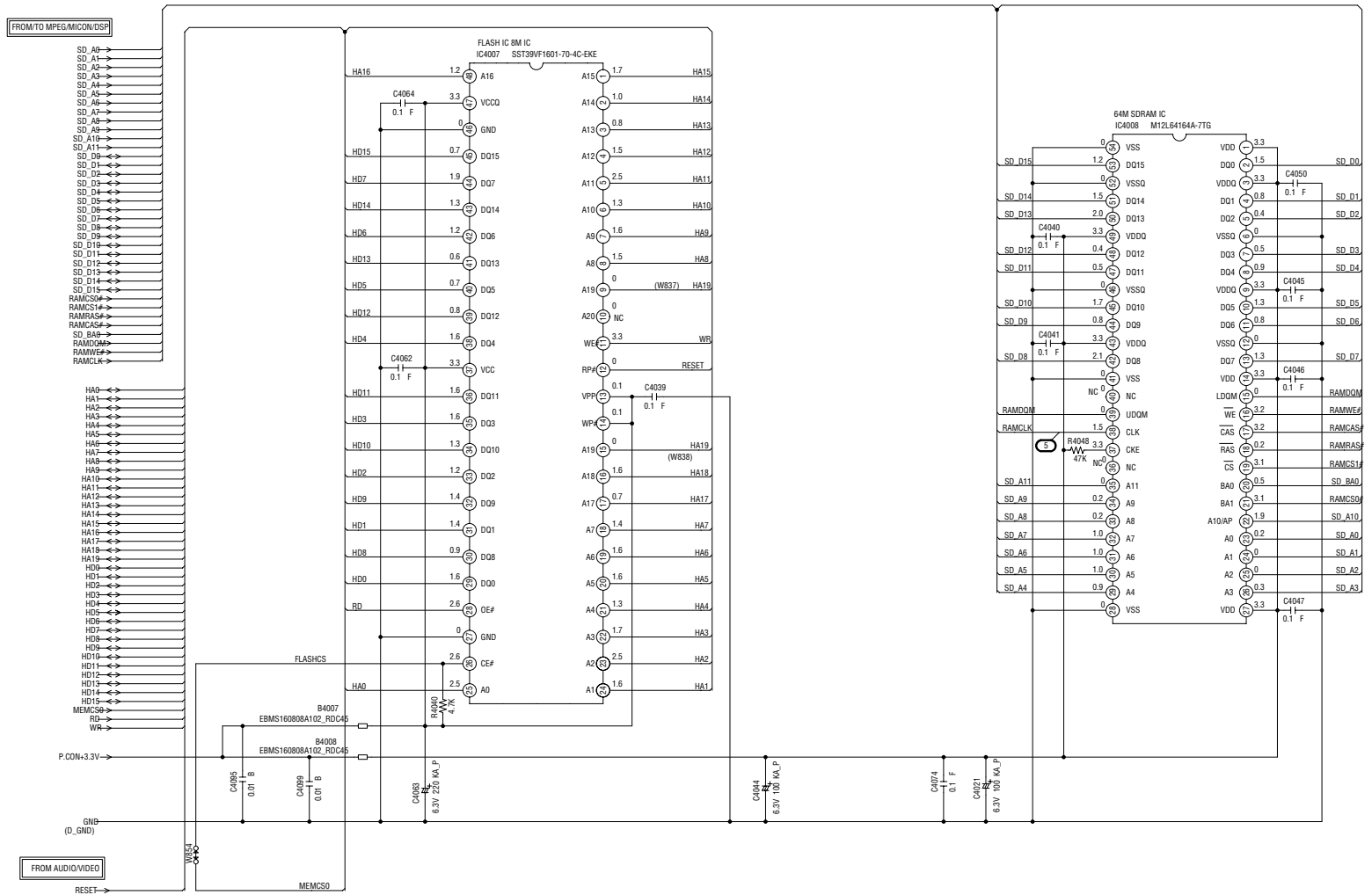

NOTE: THIS SCHEMATIC DIAGRAM IS THE LATEST AT THE TIME OF PRINTING AND SUBJECT TO CHANGE WITHOUT NOTICE.

NOTE: THE DC VOLTAGE EACH PART WAS MEASURED WITH THE DIGITAL TESTER DURING PLAYBACK.

AUDIO/VIDEO SCHEMATIC DIAGRAM (DVD MT PCB)

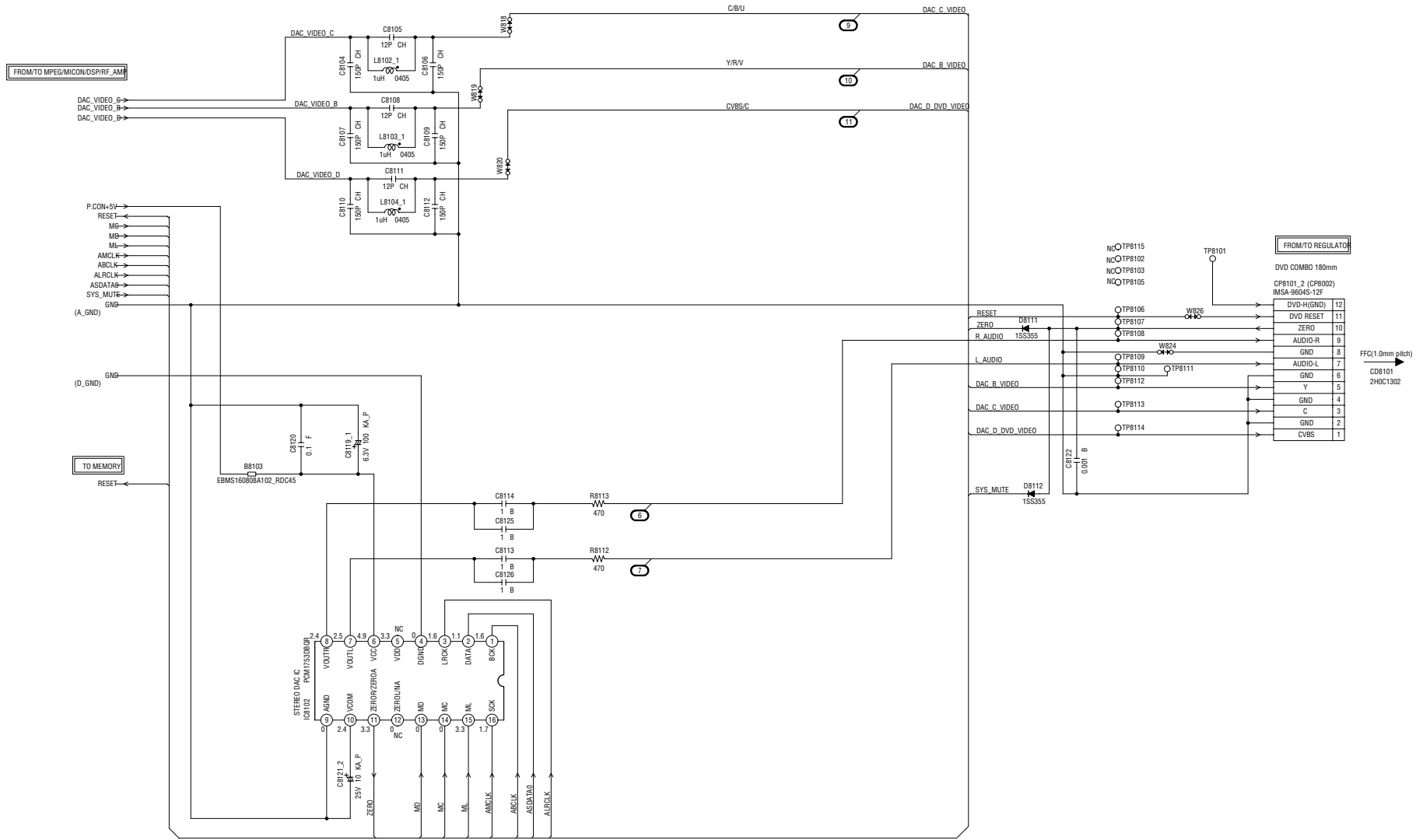

NOTE: THIS SCHEMATIC DIAGRAM IS THE LATEST AT THE TIME OF PRINTING AND SUBJECT TO CHANGE WITHOUT NOTICE.

NOTE: THE DC VOLTAGE EACH PART WAS MEASURED WITH THE DIGITAL TESTER DURING PLAYBACK.

PCB130
DME064

Y/C/AUDIO/HEAD AMP SCHEMATIC DIAGRAM (VCR MT PCB)

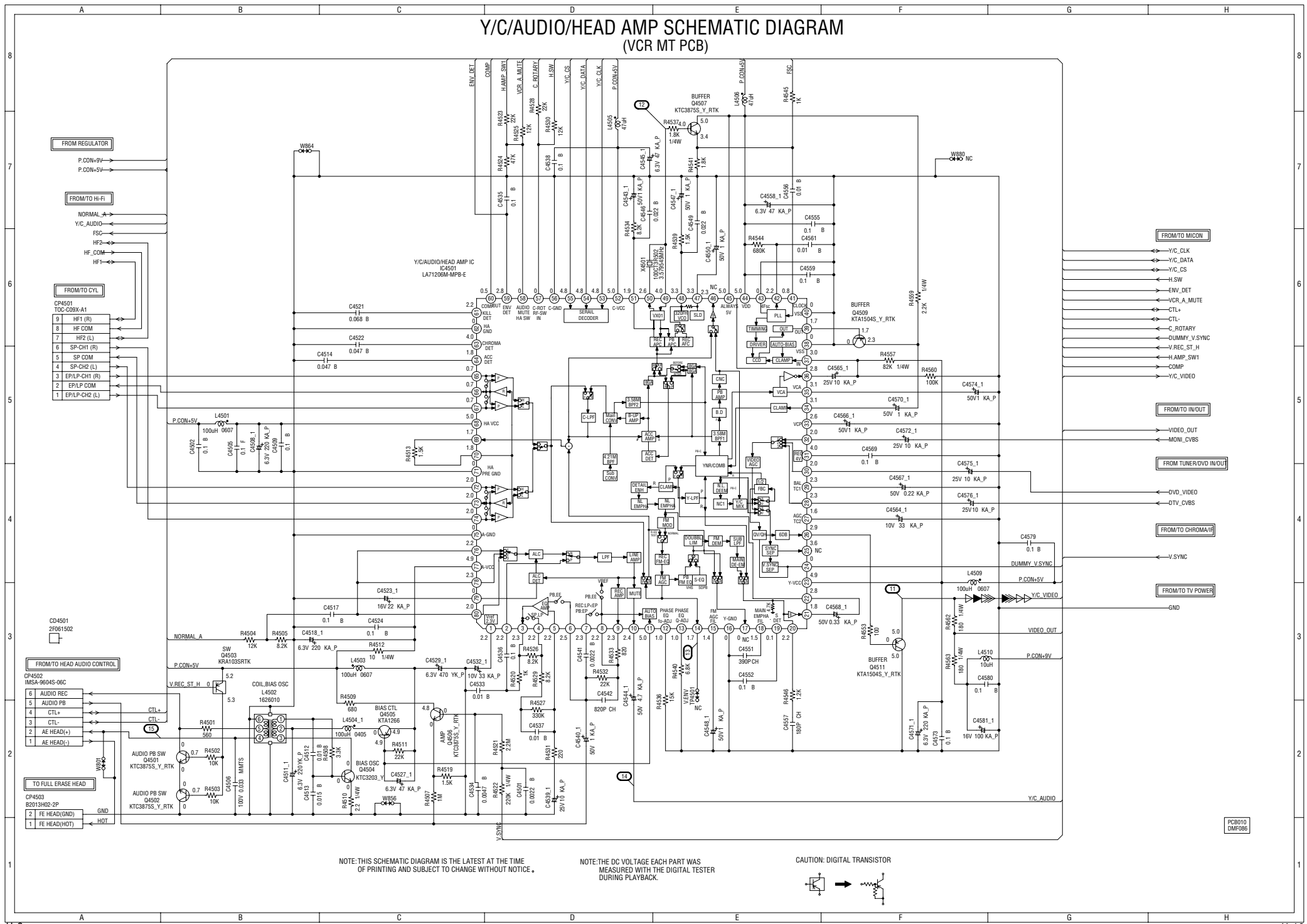

NOTE: THIS SCHEMATIC DIAGRAM IS THE LATEST AT THE TIME OF PRINTING AND SUBJECT TO CHANGE WITHOUT NOTICE.

NOTE: THE DC VOLTAGE EACH PART WAS MEASURED WITH THE DIGITAL TESTER DURING PLAYBACK.

CAUTION: DIGITAL TRANSISTOR

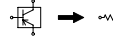

PC8010
DMF086

MICON SCHEMATIC DIAGRAM (VCR MT PCB)

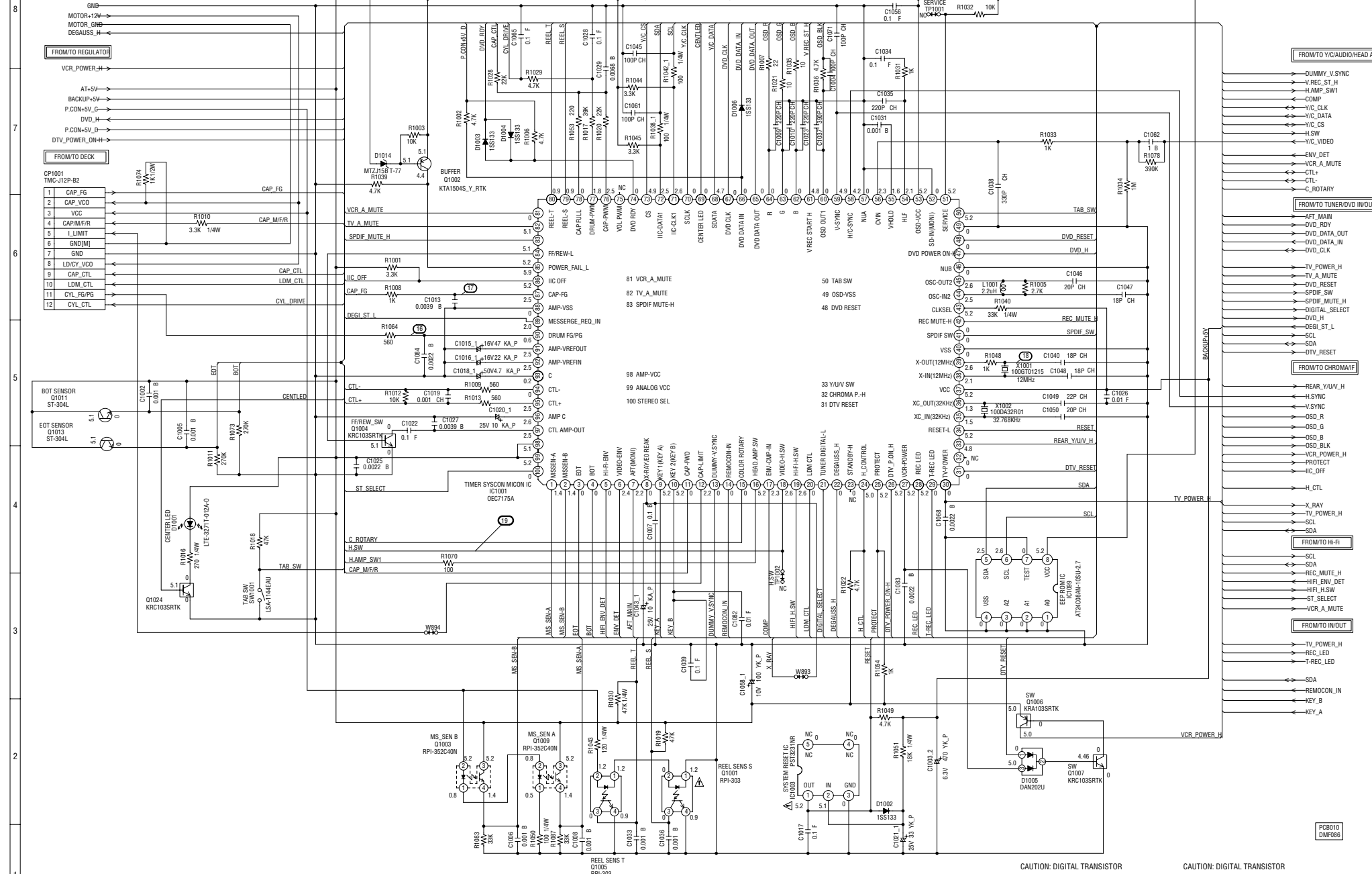

NOTE:THE DC VOLTAGE EACH PART WAS MEASURED WITH THE DIGITAL TESTER DURING PLAYBACK.

NOTE:THIS SCHEMATIC DIAGRAM IS THE LATEST AT THE TIME OF PRINTING AND SUBJECT TO CHANGE WITHOUT NOTICE.

CAUTION THESE PARTS MARKED WITH ARE CRITICAL FOR SAFETY. USE ONES DESCRIBED IN PARTS LIST ONLY.

ATTENTION LES PIECES REPARÉES PAR UN ÉTANT DANGEREUSES AN POINT DE VUE SECURITE N'UTILISER QUE CELLES DÉCRITES DANS LA NOMENCLATURE DES PIÈCES.

CAUTION: DIGITAL TRANSISTOR

CAUTION: DIGITAL TRANSISTOR

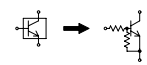
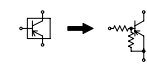

CHROMA/IF SCHEMATIC DIAGRAM (VCR MT PCB)

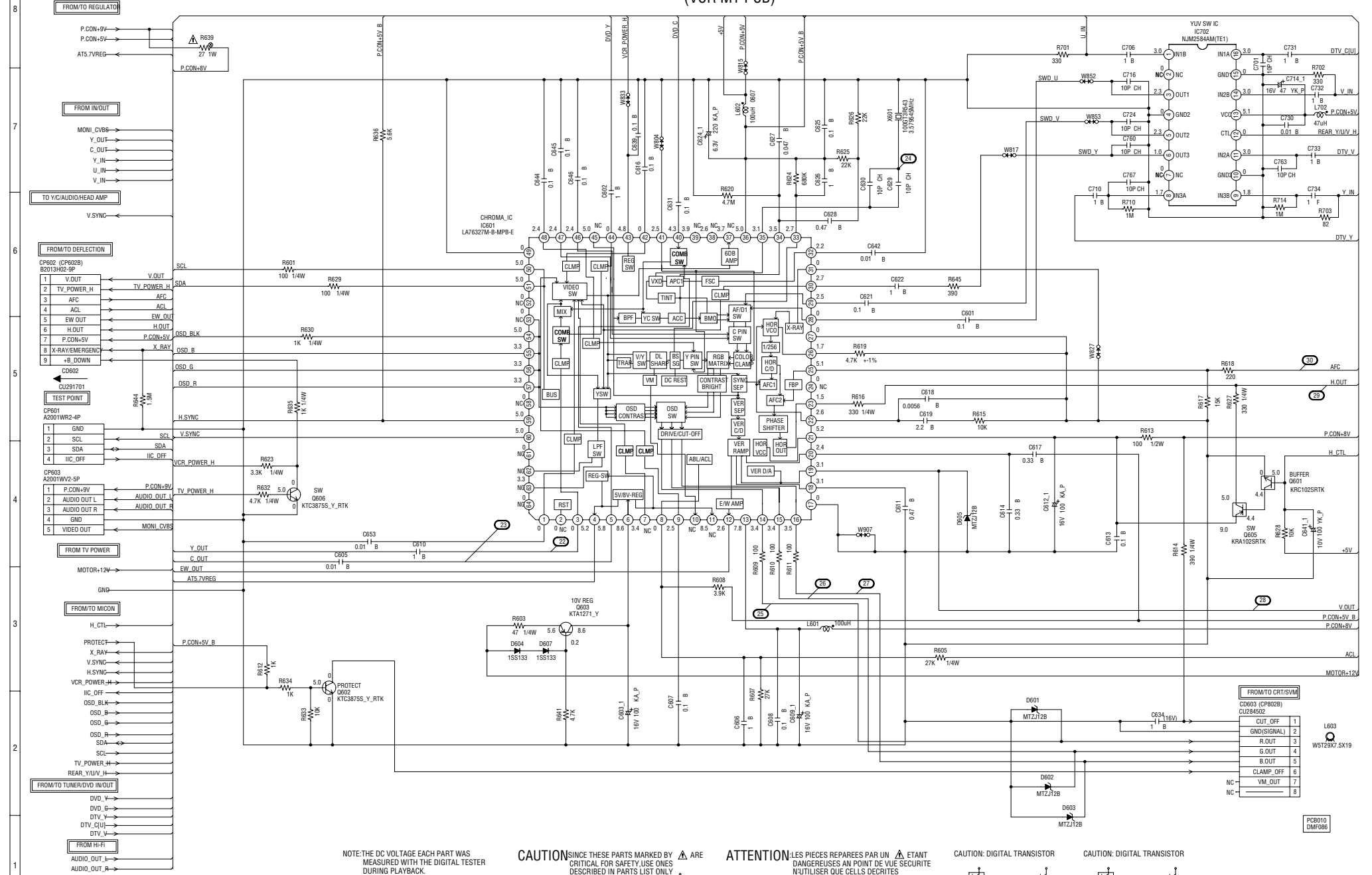

NOTE: THE DC VOLTAGE EACH PART WAS MEASURED WITH THE DIGITAL TESTER DURING PLAYBACK.

CAUTION SINCE THESE PARTS MARKED BY ARE CRITICAL FOR SAFETY, USE ONES DESCRIBED IN PARTS LIST ONLY.

ATTENTION LES PIÈCES RÉPARÉES PAR UN ÉTANT DANGEREUSES AN POINT DE VUE SECURITE UTILISER QUE CELLS DECRITES DANS LA NOMENCLATURE DES PIÈCES.

CAUTION: DIGITAL TRANSISTOR

CAUTION: DIGITAL TRANSISTOR

NOTE: THIS SCHEMATIC DIAGRAM IS THE LATEST AT THE TIME OF PRINTING AND SUBJECT TO CHANGE WITHOUT NOTICE.

FROM TO CRT/SVM	
CUT OFF	1
GND(SIGNAL)	2
R. OUT	3
G. OUT	4
B. OUT	5
CLAMP OFF	6
VM_OUT	7
NC	8

PC8010
DMP086

Hi-Fi SCHEMATIC DIAGRAM

(VCR MT PCB)

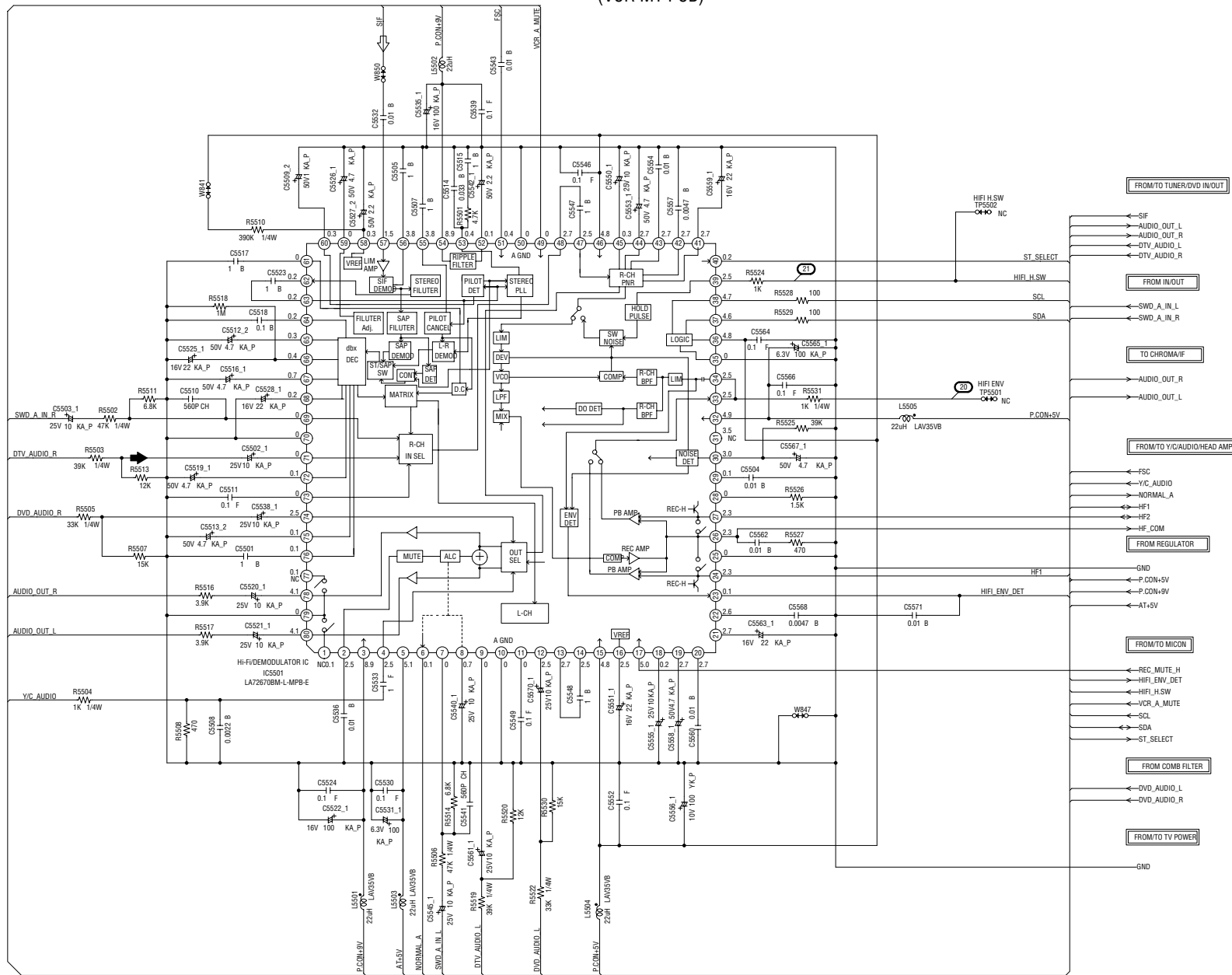

NOTE: THIS SCHEMATIC DIAGRAM IS THE LATEST AT THE TIME OF PRINTING AND SUBJECT TO CHANGE WITHOUT NOTICE.

NOTE: THE DC VOLTAGE EACH PART WAS MEASURED WITH THE DIGITAL TESTER DURING PLAYBACK.

PC8010 DMF086

TUNER/DVD IN/OUT SCHEMATIC DIAGRAM (VCR MT PCB)

FROM MPEG/MICON/DSP/R_F AMP

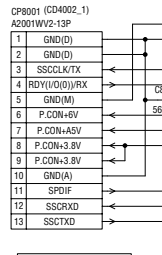

FROM TO DEFLECTION



FROM TO AUDIO/VIDEO

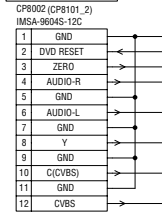

FROM TO SOUND AMP/SURROUND

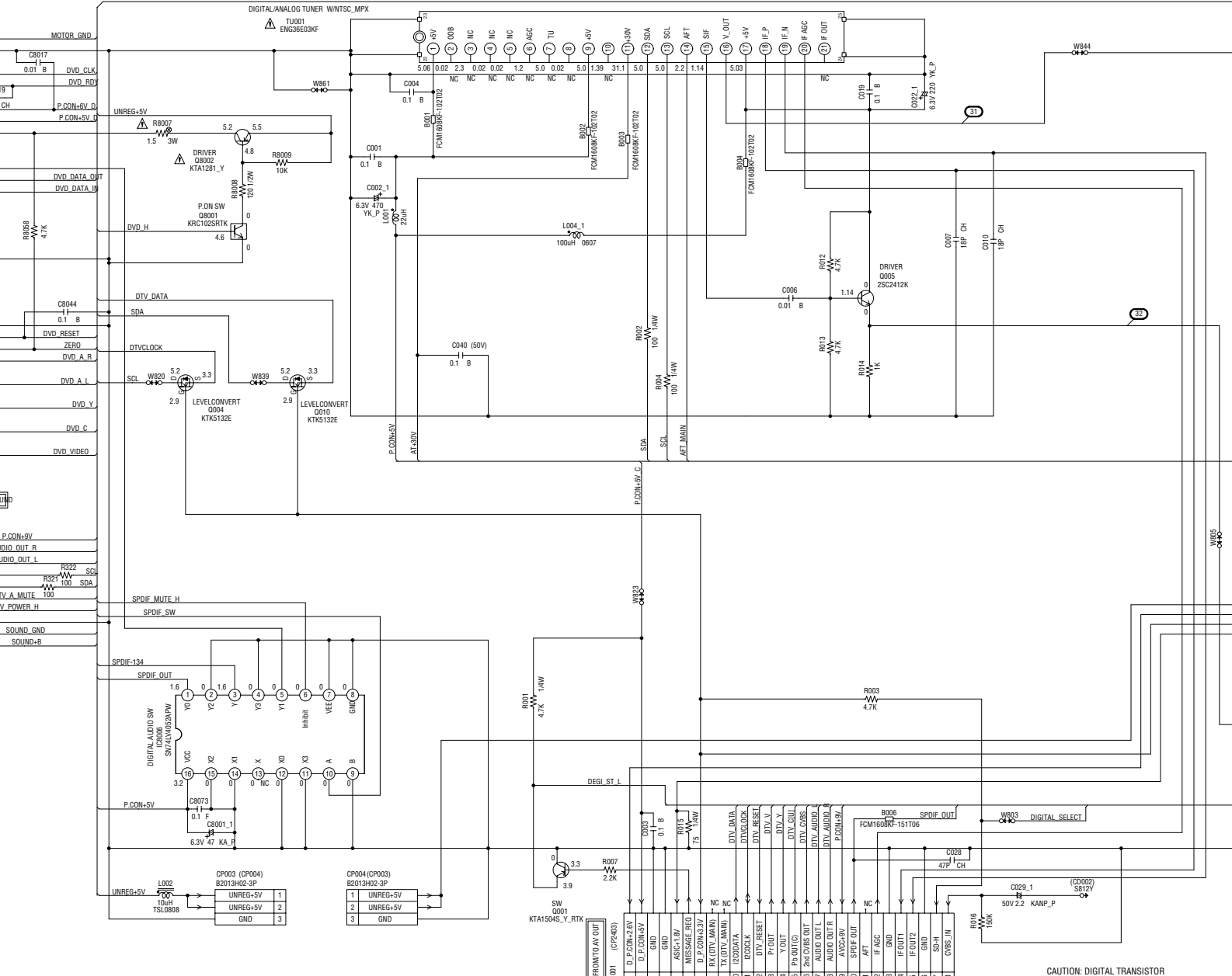
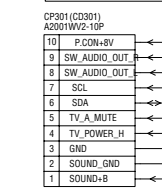

FROM TO IN/OUT

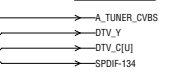

FROM TO COMB FILTER

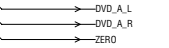

FROM TO CHROMA/IN

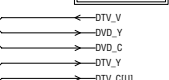

FROM TO MICON

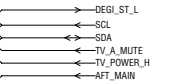

FROM TO MICON

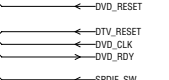

FROM TO REGULATOR

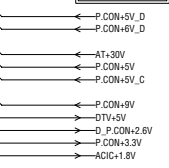

TO Y/C/AUDIO/HEAD AMP



FROM TO H-FI



FROM TV POWER

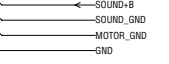

NOTE: THIS SCHEMATIC DIAGRAM IS THE LATEST AT THE TIME OF PRINTING AND SUBJECT TO CHANGE WITHOUT NOTICE.

NOTE: THE DC VOLTAGE EACH PART WAS MEASURED WITH THE DIGITAL TESTER DURING PLAYBACK.

CAUTION: SINCE THESE PARTS MARKED WITH Δ ARE DANGEROUS AS A POINT OF VIEW SECURITY DESCRIBED IN PARTS LIST ONLY.

ATTENTION: LES PIÈCES RÉPARÉES PAR UN Δ ÉTANT DANGEREUSES AN POINT DE VUE SÉCURITÉ UTILISER QUE CELLES DÉCRITES DANS LA NOMENCLATURE DES PIÈCES.

CAUTION: DIGITAL TRANSISTOR

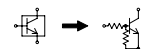

TV POWER SCHEMATIC DIAGRAM (VCR MT PCB)

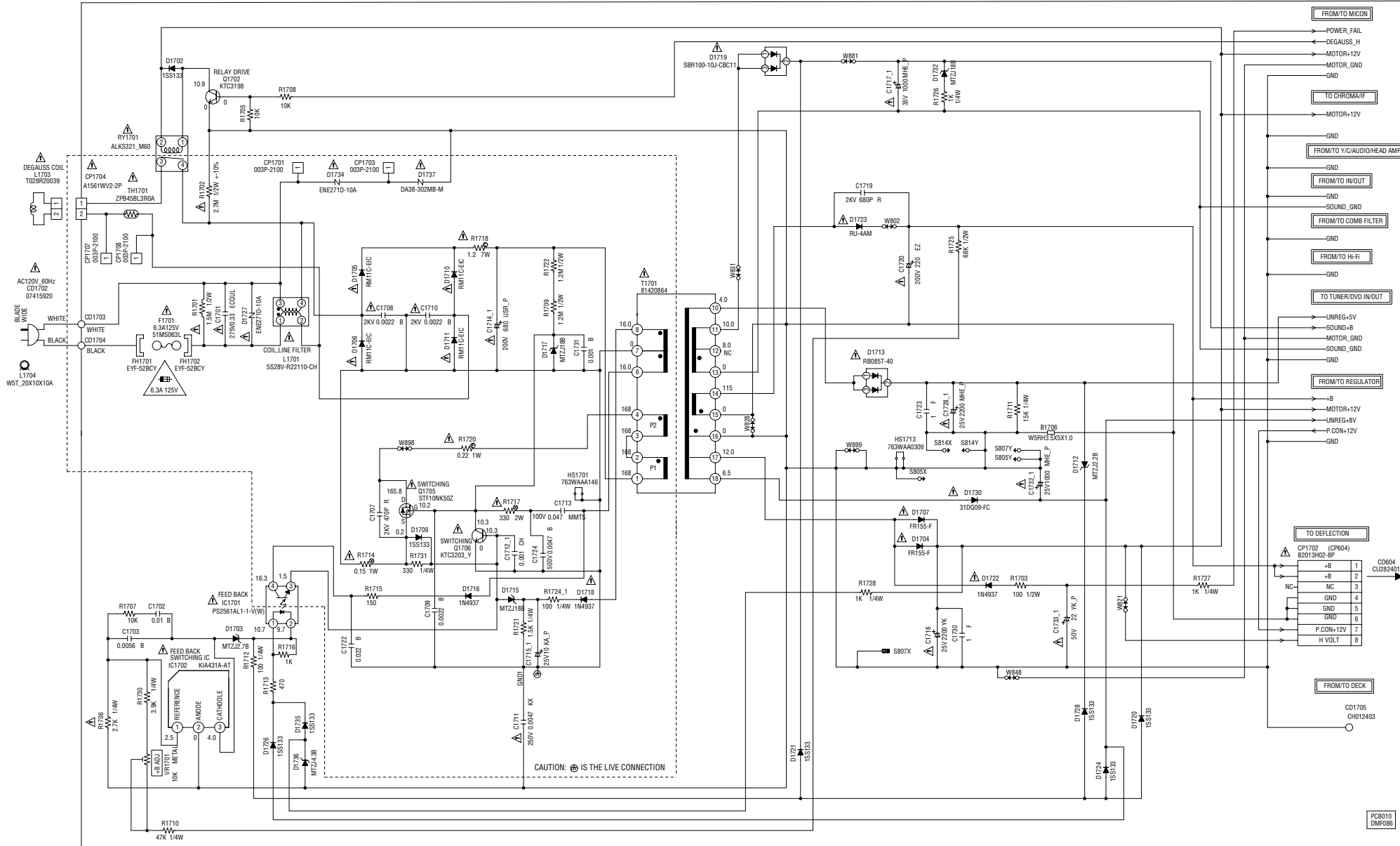

CAUTION FOR CONTINUED PROTECTION AGAINST FIRE HAZARD, REPLACE ONLY WITH THE SAME TYPE FUSE 6.3A 125V (F1701)

ATTENTION POUR UNE PROTECTION CONTINUE LES RISQUES D'INCENDIE N'UTILISER QUE DES FUSIBLES DE MEME TYPE 6.3A 125V (F1701)

NOTE: THIS SCHEMATIC DIAGRAM IS THE LATEST AT THE TIME OF PRINTING AND SUBJECT TO CHANGE WITHOUT NOTICE.

NOTE: THE DC VOLTAGE AT EACH PART WAS MEASURED WITH THE DIGITAL TESTER WHEN THE COLOR BROADCAST WAS RECEIVED IN GOOD CONDITION AND PICTURE IS NORMAL.

NOTE: THE RESISTOR MARKED F IS FUSE RESISTOR. THE ALUMI ELECTROLYTIC CAPACITOR MARKED NP IS NON POLAR ONE.

CAUTION SINCE THESE PARTS MARKED BY ARE CRITICAL FOR SAFETY USE ONES DESCRIBED IN PARTS LIST ONLY.

ATTENTION LES PIECES REPARÉES PAR UN ETANT DANGEREUSES AN POINT DE VUE SECURITE N'UTILISER QUE CELLES DECRITES DANS LA NOMENCLATURE DES PIECES.

PCB010 DMF036

DEFLECTION SCHEMATIC DIAGRAM (DEFLECTION PCB)

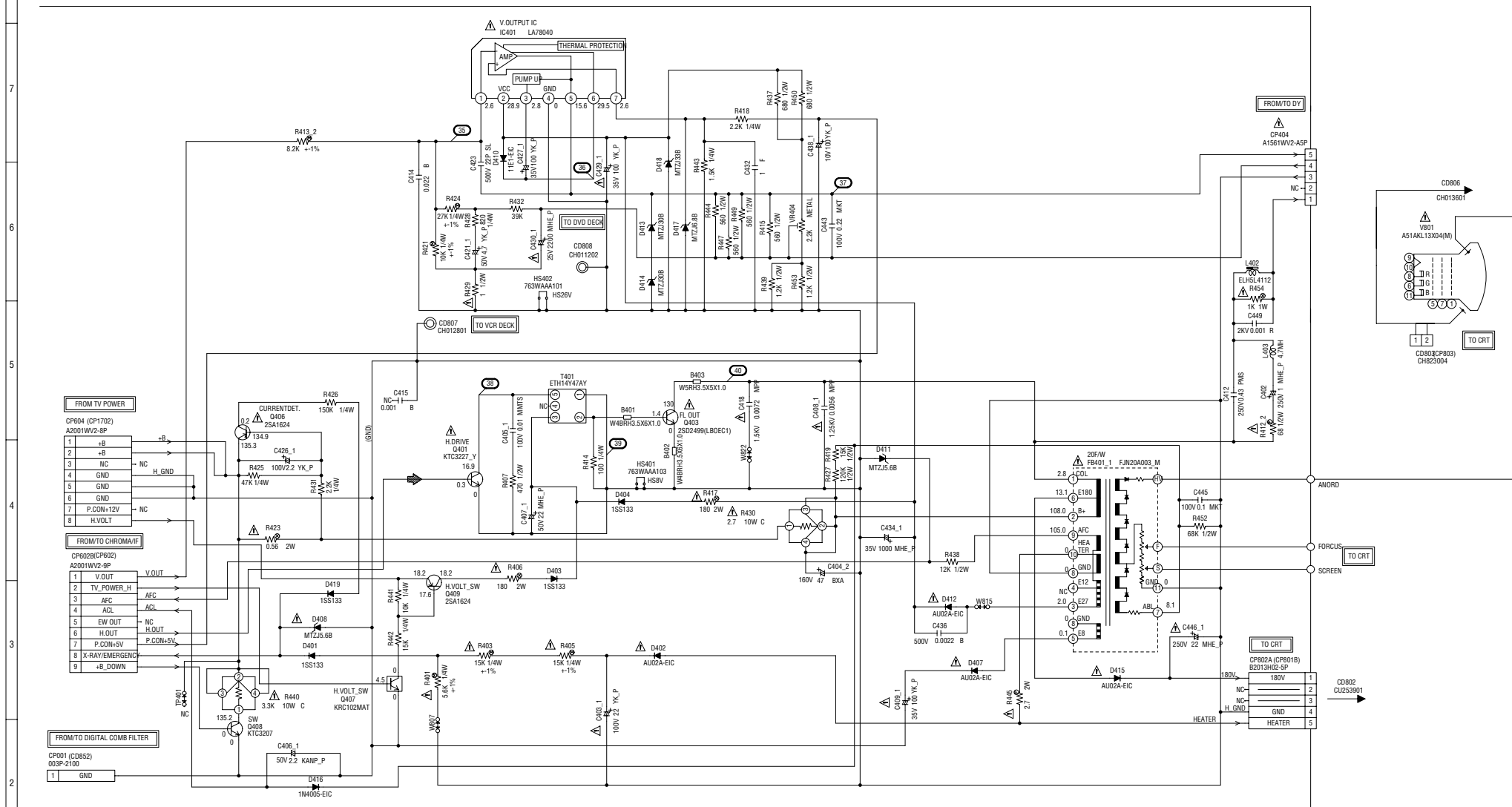

NOTE: THE DC VOLTAGE AT EACH PART WAS MEASURED WITH THE DIGITAL TESTER WHEN THE COLOR BROADCAST WAS RECEIVED IN GOOD CONDITION AND PICTURE IS NORMAL.

NOTE: THIS SCHEMATIC DIAGRAM IS THE LATEST AT THE TIME OF PRINTING AND SUBJECT TO CHANGE WITHOUT NOTICE.

CAUTION SINCE THESE PARTS MARKED BY ARE CRITICAL FOR SAFETY, USE ONES DESCRIBED IN PARTS LIST ONLY.

ATTENTION LES PIÈCES RÉPARÉES PAR UN ÉTANT DANGEREUSES À UN POINT DE VUE SÉCURITÉ, N'UTILISER QUE CELLES DÉCRITES DANS LA NOMENCLATURE DES PIÈCES.

NOTE: THE RESISTOR MARKED F IS FUSE RESISTOR. THE ALUMI ELECTROLYTIC CAPACITOR MARKED NP IS NON POLAR ONE.

CAUTION: DIGITAL TRANSISTOR



PCB080
CMP079

SOUND AMP/SURROUND SCHEMATIC DIAGRAM (DEFLECTION PCB)

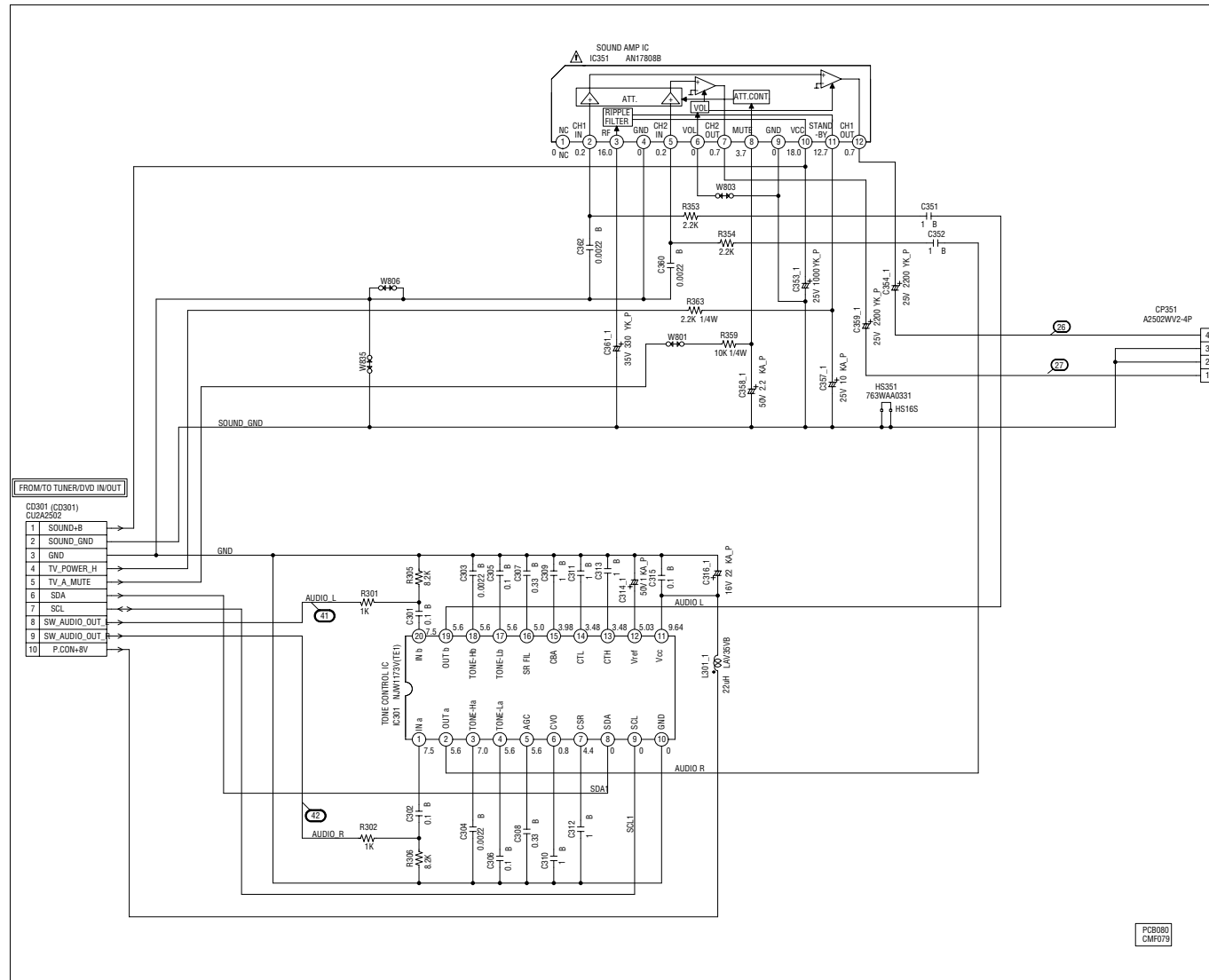

FROM/TU TUNER/DVD IN/OUT	
1	SOUND-B
2	SOUND_GND
3	GND
4	TV_POWER_H
5	TV_A_MUTE
6	SDA
7	SCL
8	SW_AUDIO_OUT
9	SW_AUDIO_OUT
10	P.CON+5V

ATTENTION LES PIÈCES RÉPARÉES PAR UN ÉTANT DANGEREUSES AN POINT DE VUE SÉCURITÉ N'UTILISER QUE CELLES DÉCRITES DANS LA NOMENCLATURE DES PIÈCES.

CAUTION SINCE THESE PARTS MARKED BY ARE CRITICAL FOR SAFETY USE ONES DESCRIBED IN PARTS LIST ONLY.

NOTE: THIS SCHEMATIC DIAGRAM IS THE LATEST AT THE TIME OF PRINTING AND SUBJECT TO CHANGE WITHOUT NOTICE.

NOTE: THE DC VOLTAGE EACH PART WAS MEASURED WITH THE DIGITAL TESTER DURING PLAYBACK.

CRT/SVM SCHEMATIC DIAGRAM (CRT PCB)

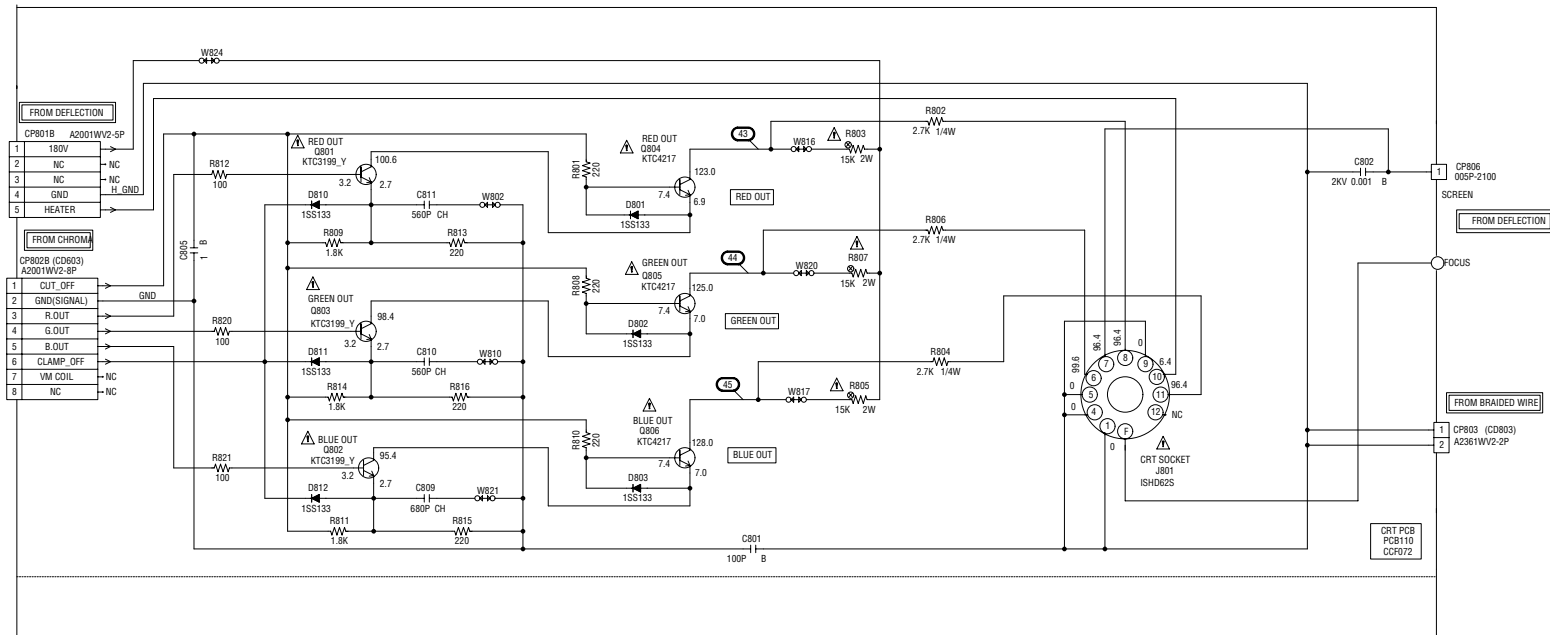

NOTE: THIS SCHEMATIC DIAGRAM IS THE LATEST AT THE TIME OF PRINTING AND SUBJECT TO CHANGE WITHOUT NOTICE.

NOTE: THE DC VOLTAGE AT EACH PART WAS MEASURED WITH THE DIGITAL TESTER WHEN THE COLOR BROADCAST WAS RECEIVED IN GOOD CONDITION AND PICTURE IS NORMAL.

CAUTION SINCE THESE PARTS MARKED BY Δ ARE CRITICAL FOR SAFETY, USE ONES DESCRIBED IN PARTS LIST ONLY.

ATTENTION LES PIÈCES RÉPARÉES PAR UN Δ ÉTANT DANGEREUSES AN POINT DE VUE SÉCURITÉ N'UTILISER QUE CELLES DÉCRITES DANS LA NOMENCLATURE DES PIÈCES.

OPERATION SCHEMATIC DIAGRAM (OPERATION PCB)

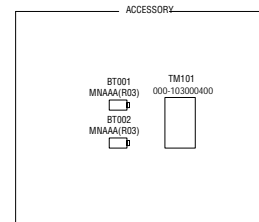
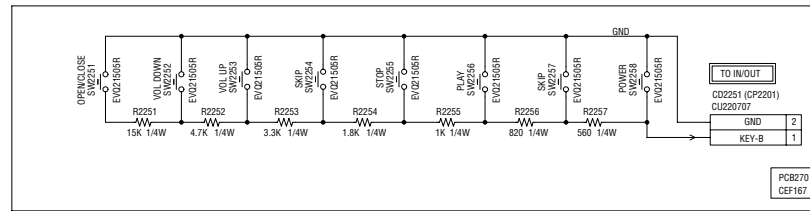

NOTE: THIS SCHEMATIC DIAGRAM IS THE LATEST AT THE TIME OF PRINTING AND SUBJECT TO CHANGE WITHOUT NOTICE.

NOTE: THE DC VOLTAGE AT EACH PART WAS MEASURED WITH THE DIGITAL TESTER WHEN THE COLOR BROADCAST WAS RECEIVED IN GOOD CONDITION AND PICTURE IS NORMAL.

POWER & GROUND SCHEMATIC DIAGRAM (DIGITAL PCB)

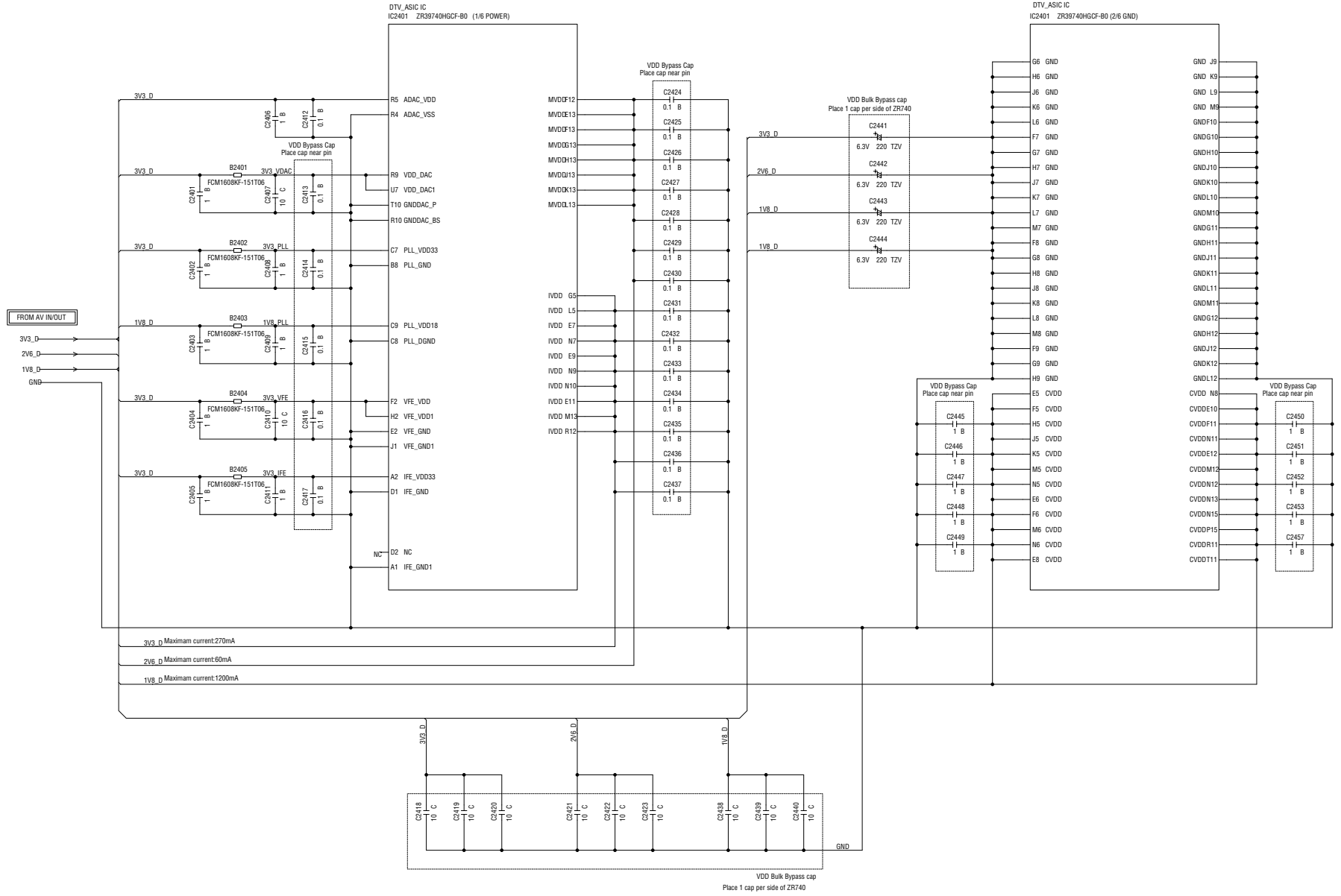

NOTE:THE DC VOLTAGE AT EACH PART WAS MEASURED WITH THE DIGITAL TESTER WHEN THE COLOR BROADCAST WAS RECEIVED IN GOOD CONDITION AND PICTURE IS NORMAL.

NOTE:THIS SCHEMATIC DIAGRAM IS THE LATEST AT THE TIME OF PRINTING AND SUBJECT TO CHANGE WITHOUT NOTICE.

PCB0H0
CEF242

SDRAM SCHEMATIC DIAGRAM (DIGITAL PCB)

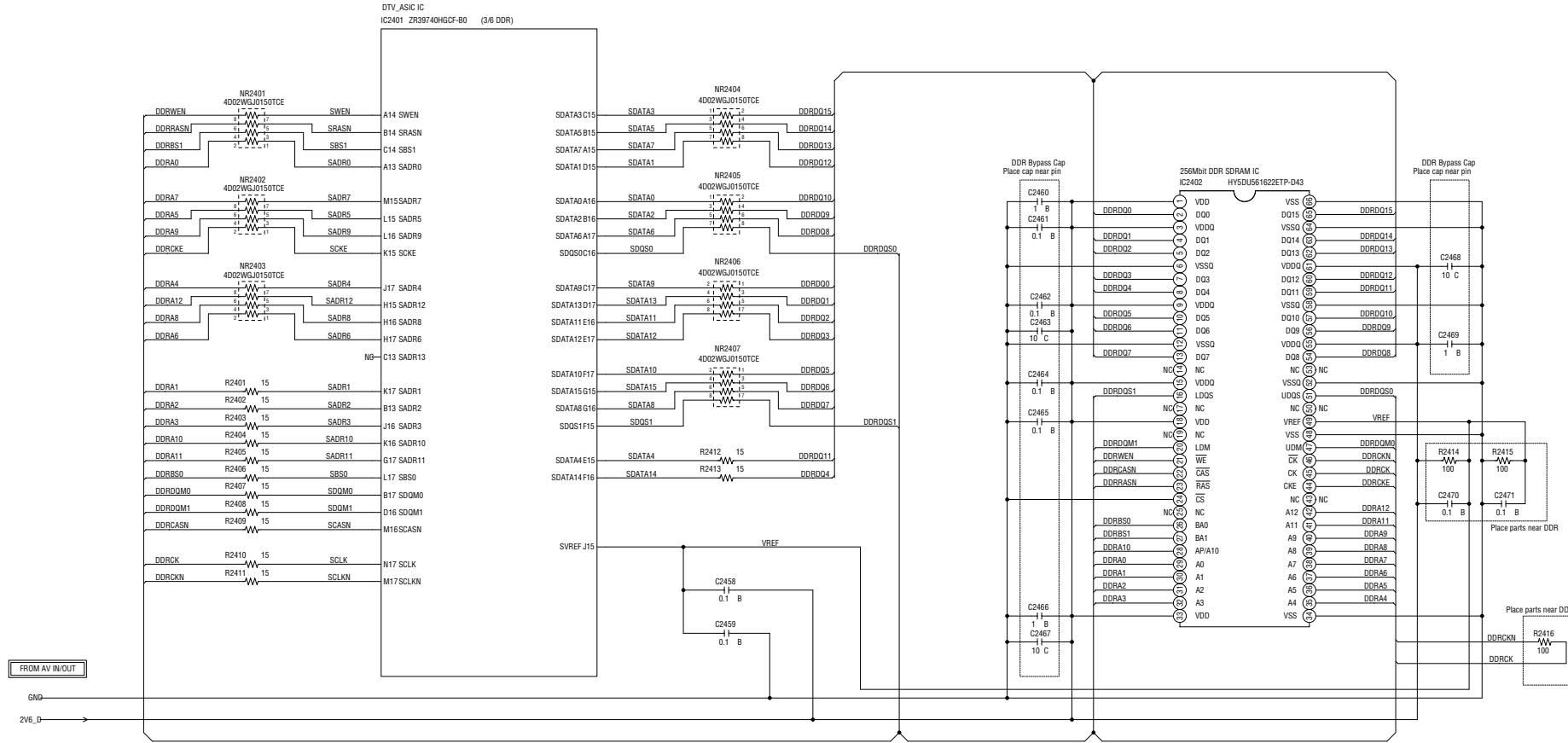

NOTE: THIS SCHEMATIC DIAGRAM IS THE LATEST AT THE TIME OF PRINTING AND SUBJECT TO CHANGE WITHOUT NOTICE.

NOTE: THE DC VOLTAGE AT EACH PART WAS MEASURED WITH THE DIGITAL TESTER WHEN THE COLOR BROADCAST WAS RECEIVED IN GOOD CONDITION AND PICTURE IS NORMAL.

PCBDH0
CEF242

FLASH/GPIO SCHEMATIC DIAGRAM (DIGITAL PCB)

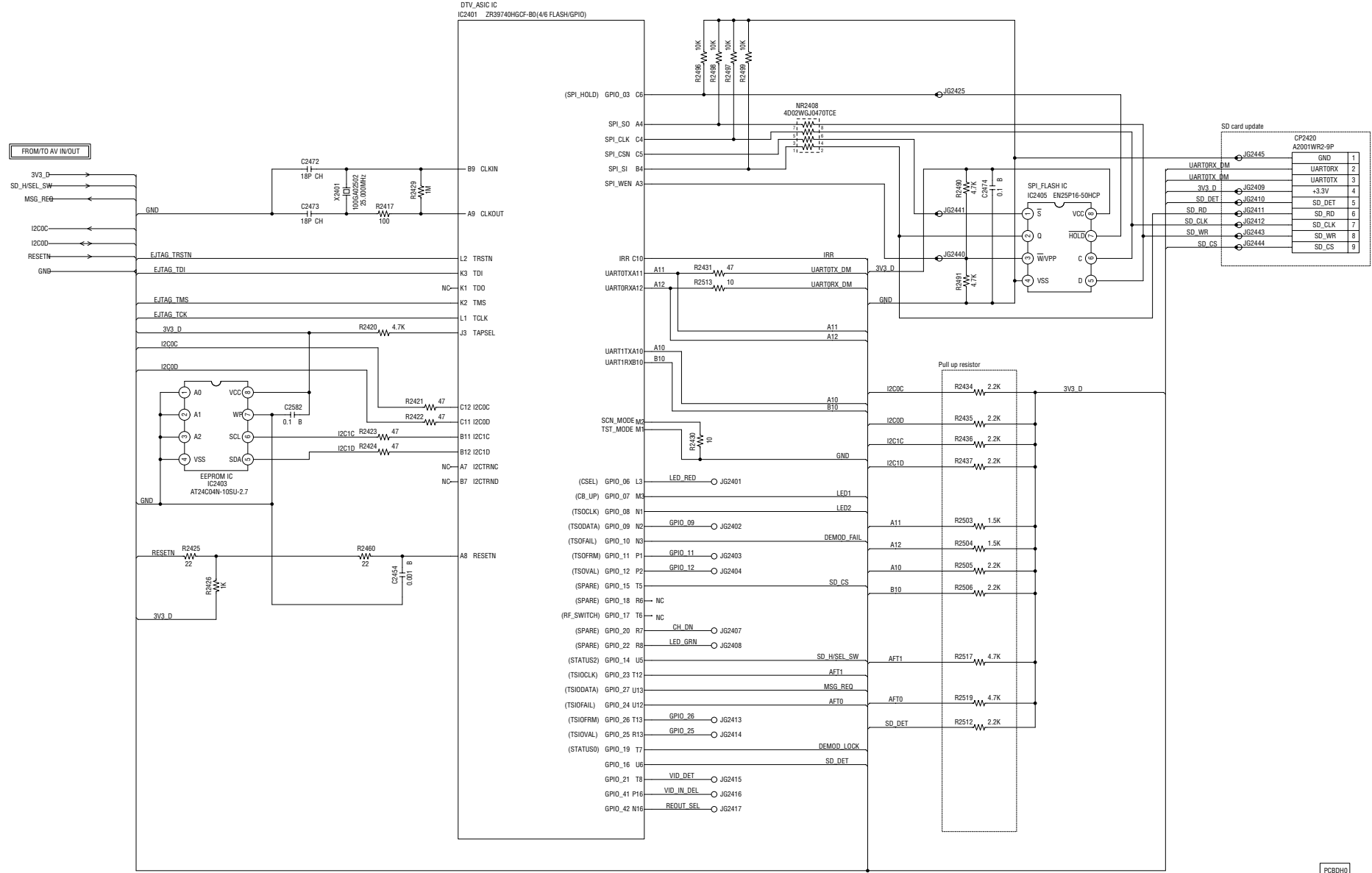

NOTE: THIS SCHEMATIC DIAGRAM IS THE LATEST AT THE TIME OF PRINTING AND SUBJECT TO CHANGE WITHOUT NOTICE.

NOTE: THE DC VOLTAGE AT EACH PART WAS MEASURED WITH THE DIGITAL TESTER WHEN THE COLOR BROADCAST WAS RECEIVED IN GOOD CONDITION AND PICTURE IS NORMAL.

PCB0H0
CF242

VIF/SIF SCHEMATIC DIAGRAM (DIGITAL PCB)

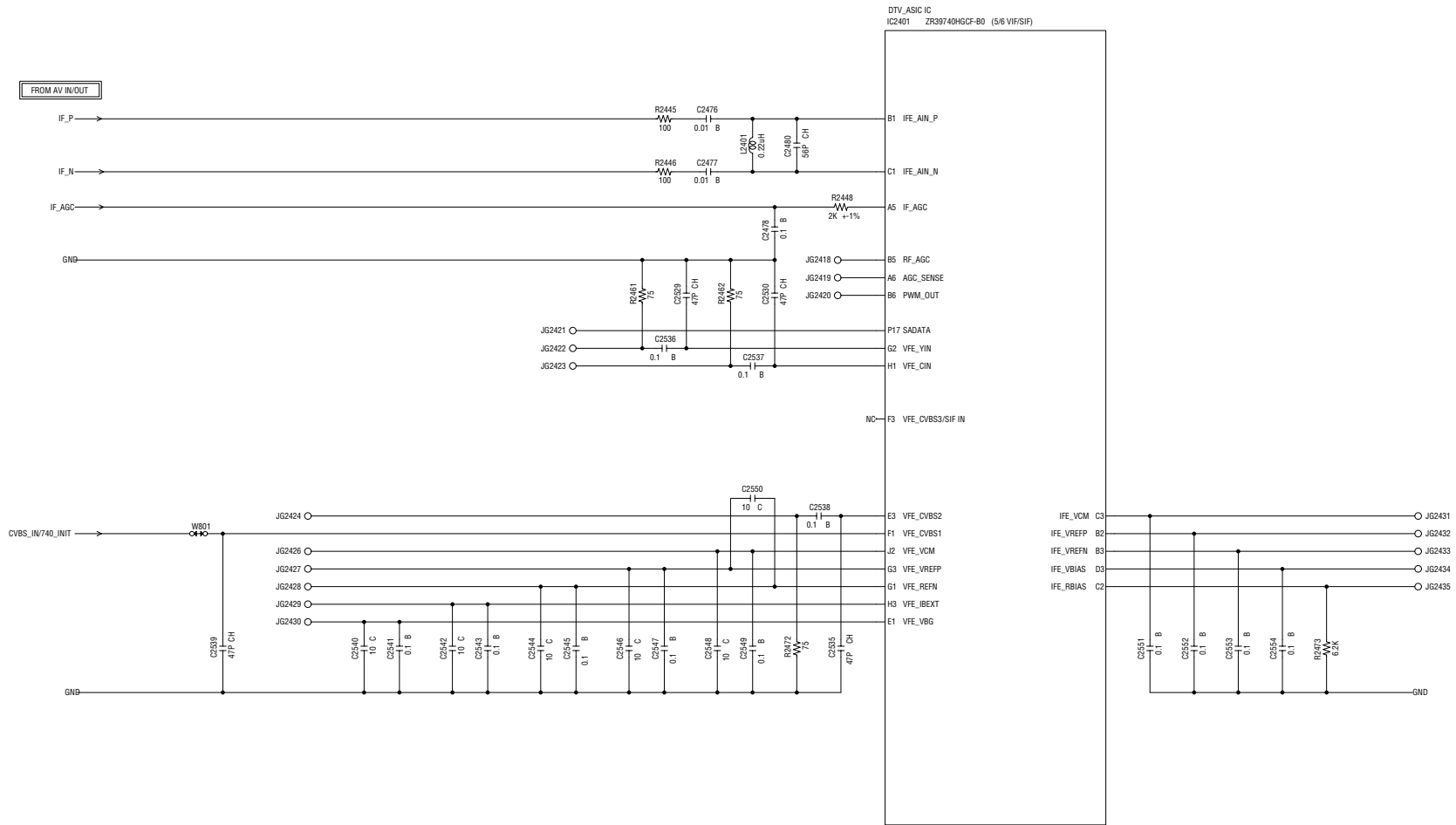

NOTE: THIS SCHEMATIC DIAGRAM IS THE LATEST AT THE TIME OF PRINTING AND SUBJECT TO CHANGE WITHOUT NOTICE.

NOTE: THE DC VOLTAGE AT EACH PART WAS MEASURED WITH THE DIGITAL TESTER WHEN THE COLOR BROADCAST WAS RECEIVED IN GOOD CONDITION AND PICTURE IS NORMAL.

PCB0H0
CEF242

AV IN/OUT SCHEMATIC DIAGRAM (DIGITAL PCB)

CP2403
IMSA-8029B-1-282136-PT1

28	CVBS_IN/740_INIT	CVBS_IN/740_INIT
27	SD_HSEL_SW	SD_HSEL_SW
26	GND	
25	IF_N	IF_N
24	IF_P	IF_P
23	GND	
22	IF_AGC	IF_AGC
21	AF_T1	NC
20	SPDIF	SPDIF
19	+9V	+9V
18	AUDIO_R	AUDIO_R
17	AUDIO_L	AUDIO_L
16	SIF2ND_CVBS	SIF2ND_CVBS
15	Pb_OUT	Pb_OUT
14	Y_OUT	Y_OUT
13	Pr_OUT	Pr_OUT
12	DTV_RESET	DTV_RESET
11	I2C_CLK	I2C_CLK
10	I2C_DATA	I2C_DATA
9	TX(DM_MAIN)	NC
8	RX(DM_MAIN)	NC
7	3V3_D	+3.3V
6	AFT0MSG_REQ	
5	1V8_D	+1.8V
4	GND	
3	5V_D	+5V
2	GND	
1	2V6_D	+2.6V

CP2403 Pin assignment:
Please refer the pin assignment table on page 6.

NOTE: THIS SCHEMATIC DIAGRAM IS THE LATEST AT THE TIME OF PRINTING AND SUBJECT TO CHANGE WITHOUT NOTICE.

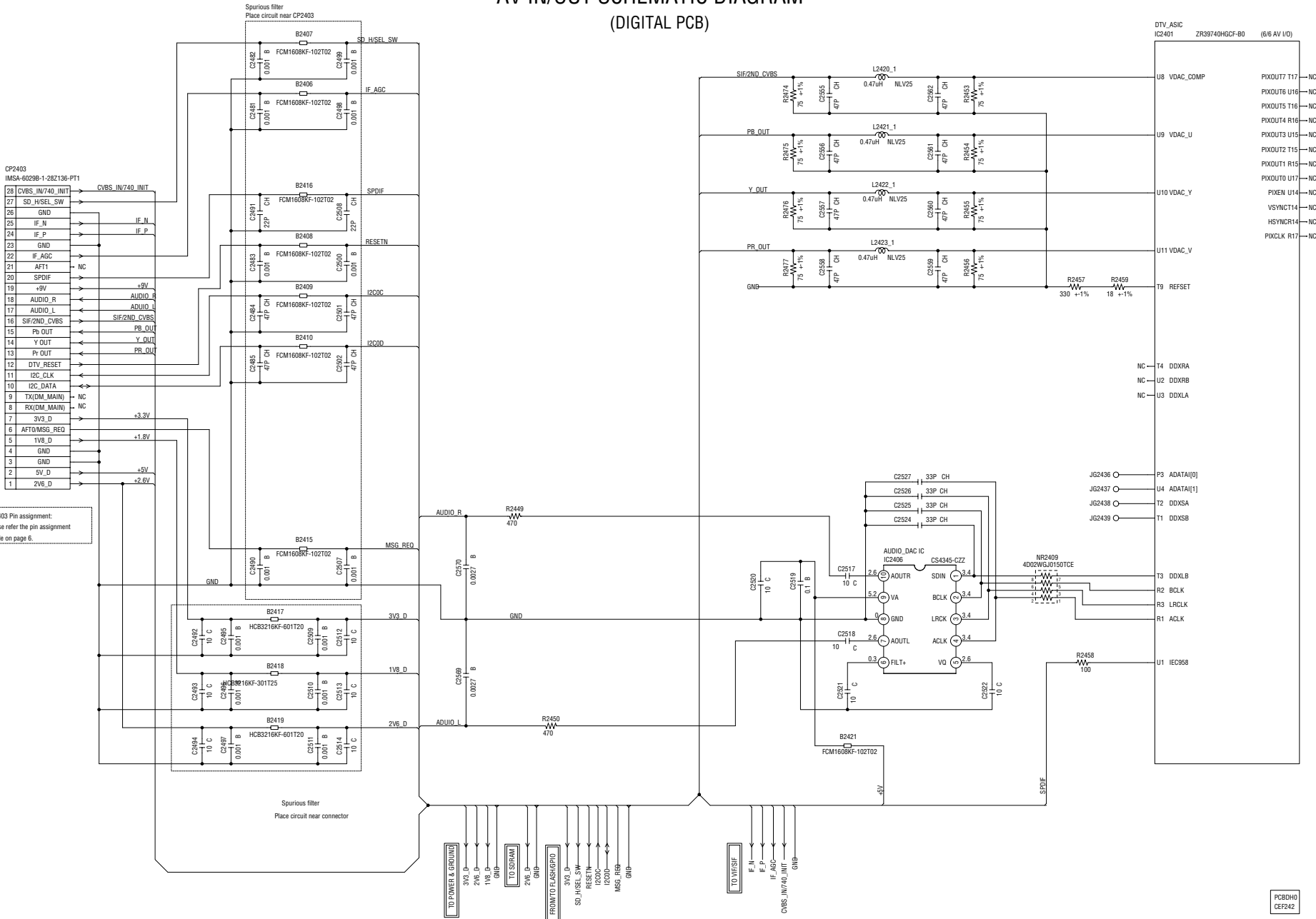

NOTE: THE DC VOLTAGE AT EACH PART WAS MEASURED WITH THE DIGITAL TESTER WHEN THE COLOR BROADCAST WAS RECEIVED IN GOOD CONDITION AND PICTURE IS NORMAL.

PCBDH0
CE242

LOADING MOTOR/SW SCHEMATIC DIAGRAM

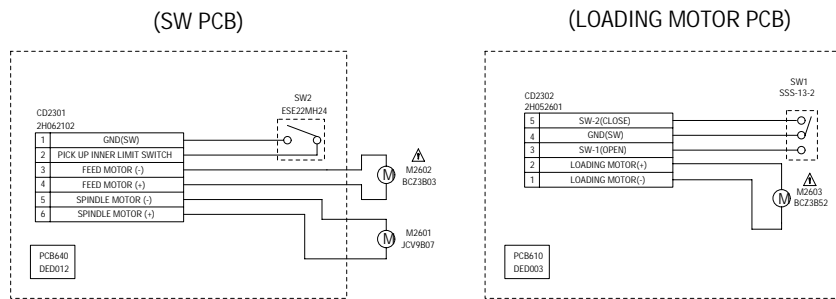

CAUTION SINCE THESE PARTS MARKED BY ARE CRITICAL FOR SAFETY, USE ONES DESCRIBED IN PARTS LIST ONLY.

ATTENTION LES PIÈCES RÉPARÉES PAR UN ÉTANT DANGEREUSES AN POINT DE VUE SECURITE N'UTILISER QUE CELLES DÉCRITES DANS LA NOMENCLATURE DES PIÈCES.

NOTE: THIS SCHEMATIC DIAGRAM IS THE LATEST AT THE TIME OF PRINTING AND SUBJECT TO CHANGE WITHOUT NOTICE.

WAVEFORMS

MPEG/MICON/DSP

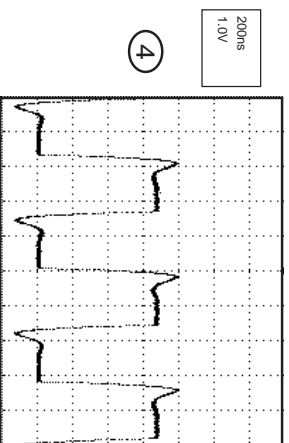
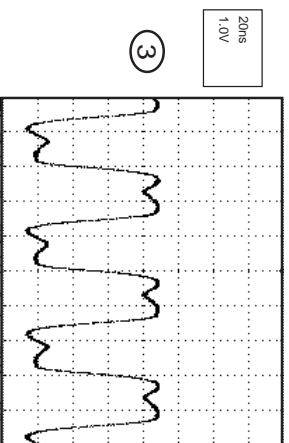
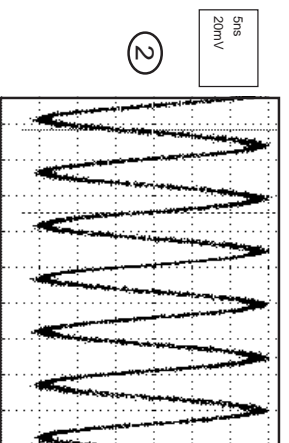
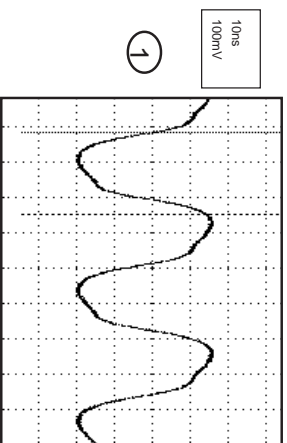

MEMORY

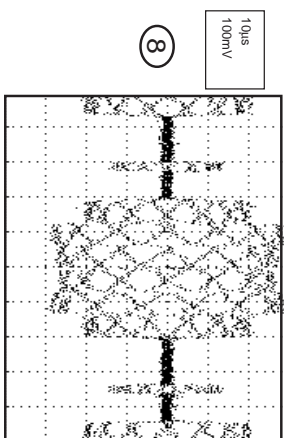
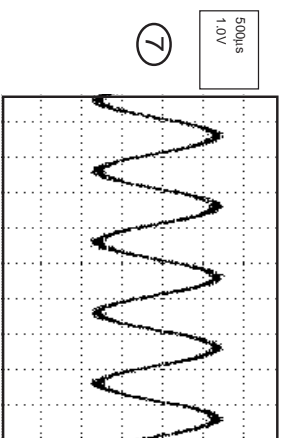
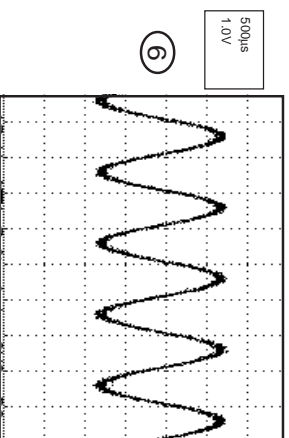
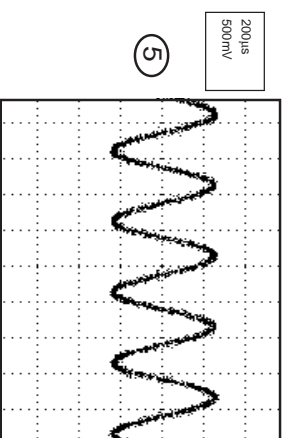

MEMORY

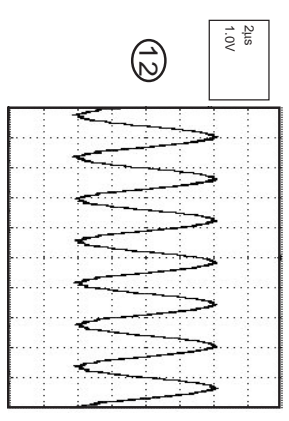
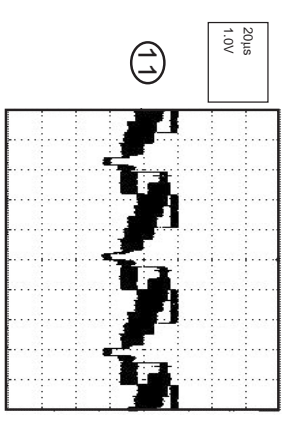
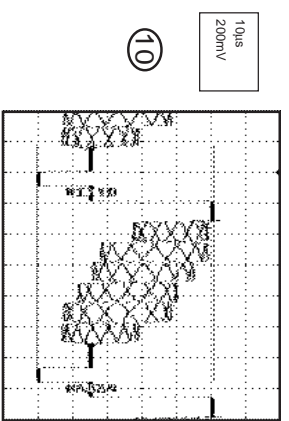
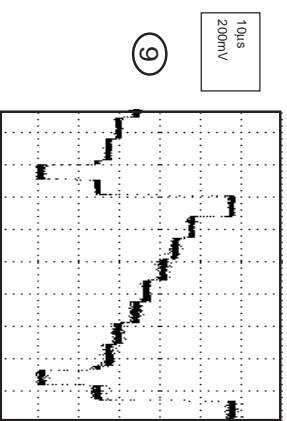

AUDIO/VIDEO

Y/CAUDIO/HEAD AMP

NOTE: The following waveforms were measured at the point of the corresponding balloon number in the schematic diagram.

WAVEFORMS

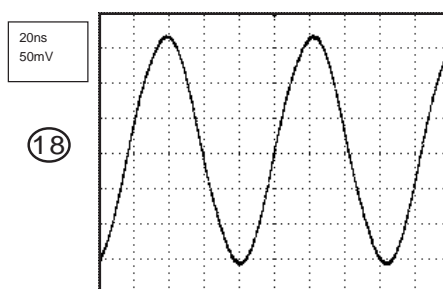
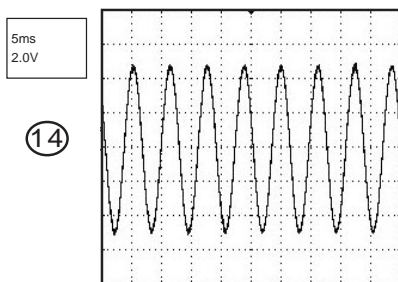
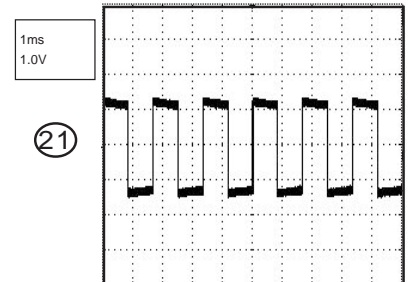
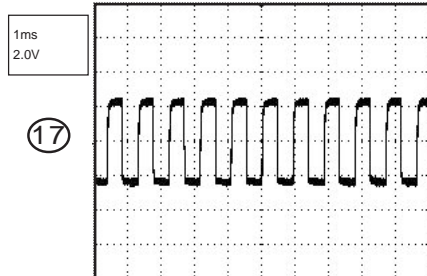
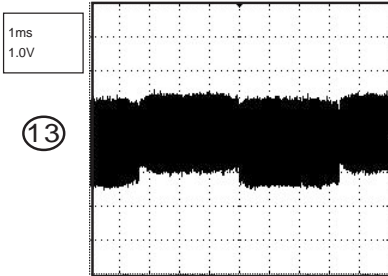

CHROMA/IF

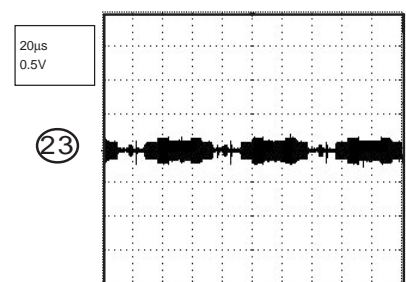
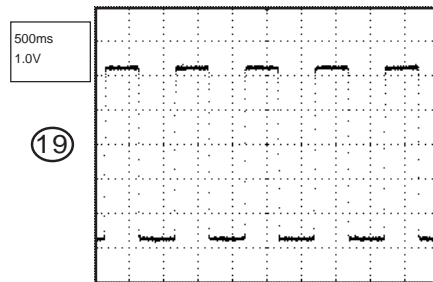
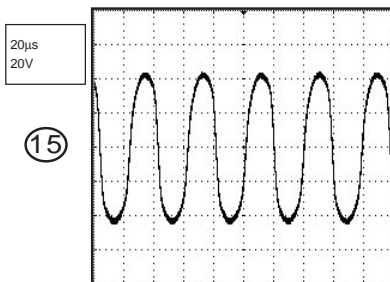
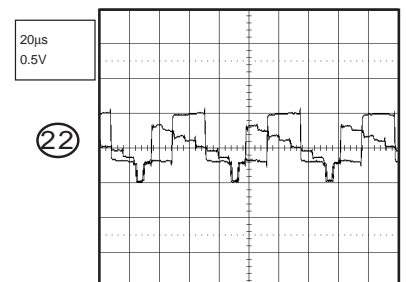

MICON

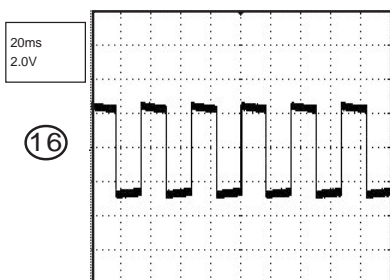

Hi-Fi

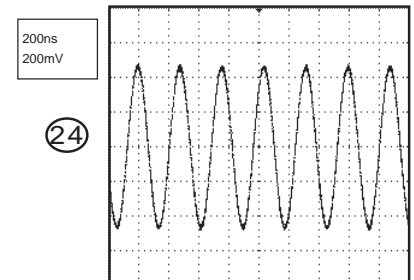
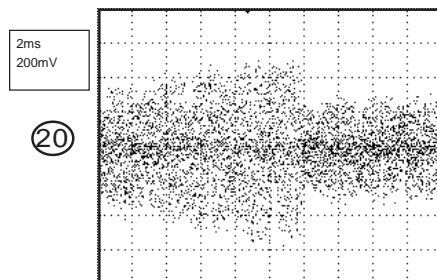

NOTE: The following waveforms were measured at the point of the corresponding balloon number in the schematic diagram.

WAVEFORMS

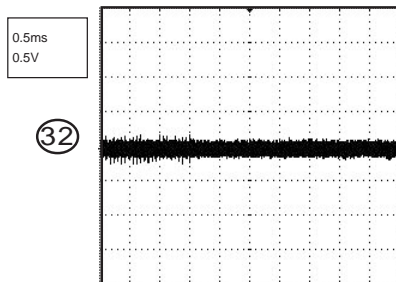
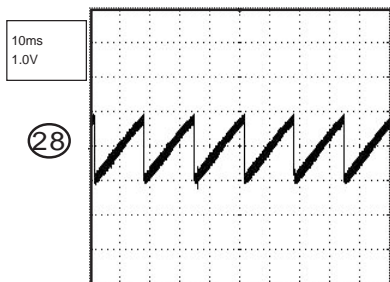
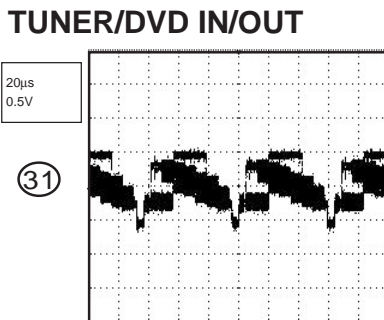
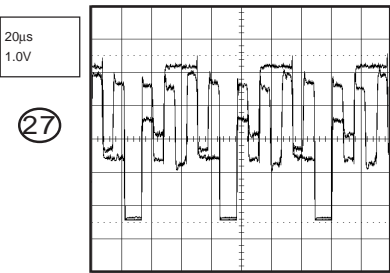
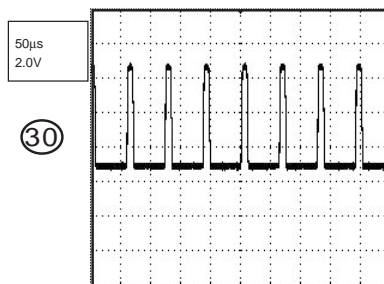
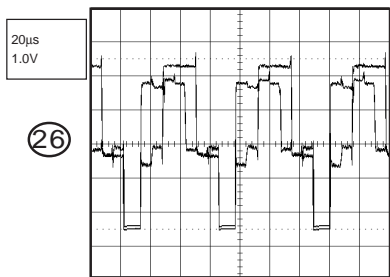
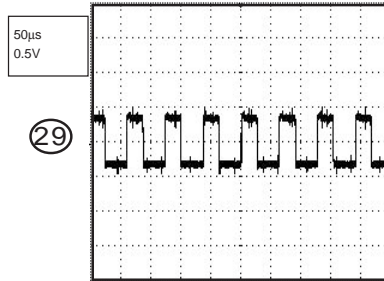
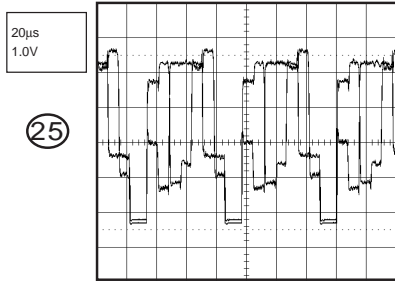

COMB FILTER

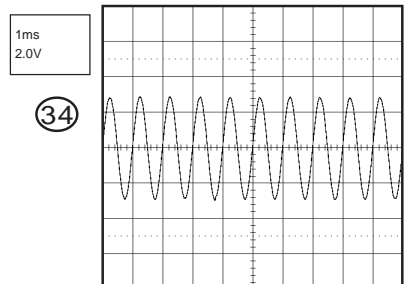
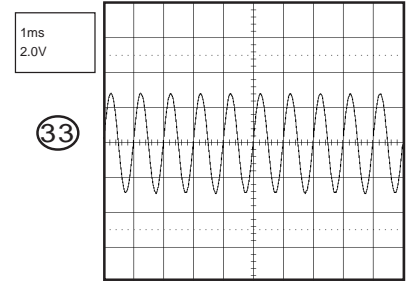

DEFLECTION

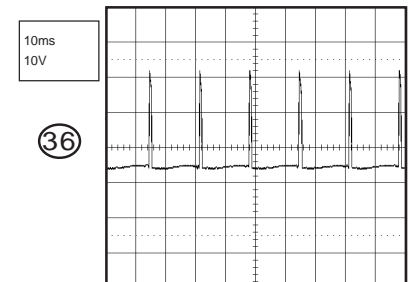
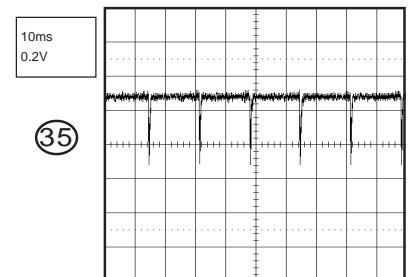

NOTE: The following waveforms were measured at the point of the corresponding balloon number in the schematic diagram.

WAVEFORMS

SOUND AMP/ SURROUND

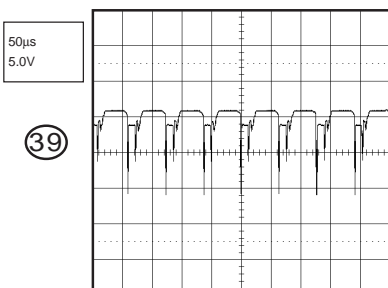
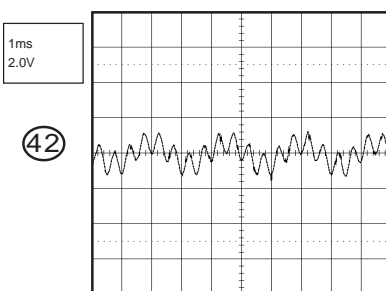
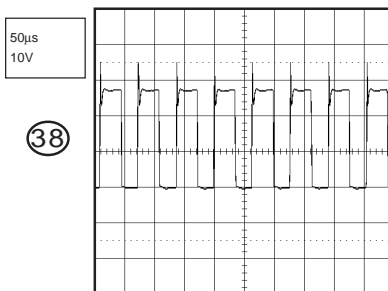
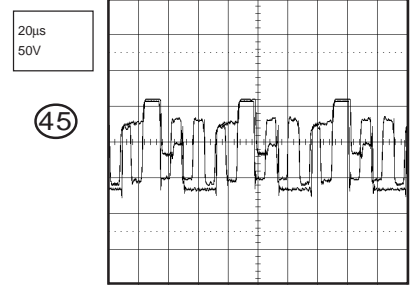
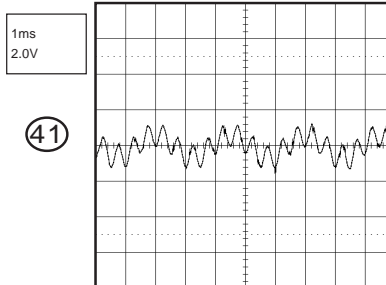
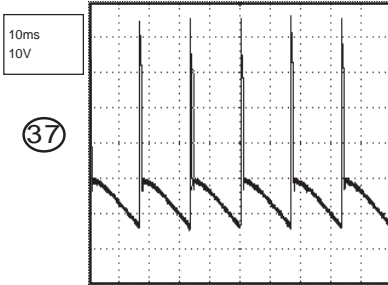

CRT

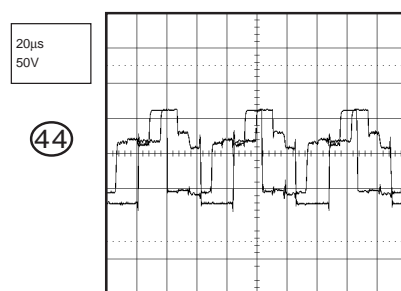
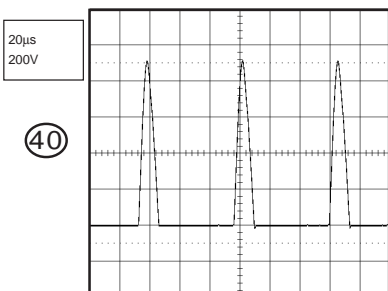
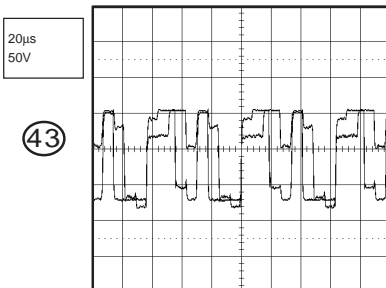

NOTE: The following waveforms were measured at the point of the corresponding balloon number in the schematic diagram.

TOSHIBA CORPORATION

1-1, SHIBAURA 1-CHOME, MINATO-KU, TOKYO 105-8001, JAPAN