

HP EliteBook 6930p Notebook PC

Maintenance and Service Guide



© Copyright 2008 Hewlett-Packard
Development Company, L.P.

Bluetooth is a trademark owned by its proprietor and used by Hewlett-Packard Company under license. Intel and Core are trademarks of Intel Corporation in the United States and other countries. Java is a US trademark of Sun Microsystems, Inc. Microsoft, Windows, and Windows Vista are U.S. registered trademarks of Microsoft Corporation in the United States. SD Logo is a trademark of its proprietor.

The information contained herein is subject to change without notice. The only warranties for HP products and services are set forth in the express warranty statements accompanying such products and services. Nothing herein should be construed as constituting an additional warranty. HP shall not be liable for technical or editorial errors or omissions contained herein.

First Edition: August 2008

Document Part Number: 462940-001

Safety warning notice

-
- ⚠ **WARNING!** To reduce the possibility of heat-related injuries or of overheating the computer, do not place the computer directly on your lap or obstruct the computer air vents. Use the computer only on a hard, flat surface. Do not allow another hard surface, such as an adjoining optional printer, or a soft surface, such as pillows or rugs or clothing, to block airflow. Also, do not allow the AC adapter to contact the skin or a soft surface, such as pillows or rugs or clothing, during operation. The computer and the AC adapter comply with the user-accessible surface temperature limits defined by the International Standard for Safety of Information Technology Equipment (IEC 60950).
-

Table of contents

1 Product description

2 External component identification

Top components	8
Display	8
Antennae	9
Button, switches, and fingerprint reader	10
Keys	11
Lights	12
Pointing devices	13
Front components	14
Rear components	15
Right-side components	15
Left-side components	16
Bottom components	17

3 Illustrated parts catalog

Serial number location	18
Computer major components	19
Plastics Kit	25
Cable Kit	26
Mass storage devices	27
Miscellaneous parts	28
Sequential part number listing	29

4 Removal and replacement procedures

Preliminary replacement requirements	35
Tools required	35
Service considerations	35
Plastic parts	35
Cables and connectors	36
Drive handling	36
Grounding guidelines	37

Electrostatic discharge damage	37
Packaging and transporting guidelines	38
Workstation guidelines	38
Equipment guidelines	39
Unknown user password	40
Component replacement procedures	41
Service tag	41
Computer feet	42
Battery	43
SIM	44
Display inverter	45
Bluetooth module	47
Hard drive	49
Optical drive	51
Upgrade bay device	52
Expansion memory module	54
WWAN module	55
Keyboard	57
Primary memory module	59
Modem module	61
WLAN module	62
RTC battery	65
Switch cover	66
Power button board	68
Fan	69
Heat sink	70
Processor	75
Display assembly	77
Top cover	82
TouchPad	84
Fingerprint reader board	86
Bluetooth module cable	87
Speaker	88
Audio/ExpressCard assembly	89
Modem module cable	90
System board	92

5 Computer Setup

Starting Computer Setup	95
Using Computer Setup	95
Navigating and selecting in Computer Setup	95
Restoring factory settings in Computer Setup	96
Computer Setup menus	97

File menu	97
Security menu	97
Diagnostics menu	98
System Configuration menu	99

6 Specifications

Computer specifications	101
14.1-inch, WXGA display specifications	102
Hard drive specifications	103
DVD±RW and CD-RW Double-Layer Combo Drive specifications	104
DVD/CD-RW Combo Drive specifications	105
DVD-ROM Drive	106
System DMA specifications	107
System interrupt specifications	108
System I/O address specifications	109
System memory map specifications	111

7 Screw listing

Phillips PM2.0×5.0 captive screw	113
Phillips PM2.5×11.0 captive screw	114
Phillips PM3.0×4.0 screw	115
Phillips 2.5×9.0 captive screw	116
Phillips PM2.0×3.0 screw	117
Phillips PM2.5×4.0 screw	118
Phillips PM2.5×4.0 screw	119
Phillips PM2.0×3.0 broad-head screw	121
Torx8 T8M2.5×7.0 screw	123
Phillips PM2.5×7.0 screw	125
Phillips PM2.5×11.0 captive screw	127
Phillips PM2.0×5.0 screw	128

8 Backup and recovery in Windows Vista

Overview	129
Creating recovery discs	130
Backing up your information	131
Backup tips	131
Backing up individual files or folders	132
Scheduling an automatic backup	132
Creating system restore points	133
Performing a recovery	134
Recovering individual files	134
Restoring the computer to a previous state	135
Recovering information using f8 recovery tools	135

Recovering information using Windows Recovery Environment (WinRE)	136
Recovering information using Recovery Manager	137
Recovering the entire hard drive using f11	137
Recovering information using a Windows Vista operating system DVD (purchased separately)	138

9 Backup and recovery in Windows XP

Backing up your information	139
When to back up	139
Backup suggestions	140
Backing up individual files or folders	140
Backing up all files and folders	141
Creating recovery points	141
Scheduling backups	142
Performing a recovery	142
Initiating a recovery in Windows	142

10 Connector pin assignments

1394	143
Audio-in (microphone)	144
Audio-out (headphone)	144
External monitor	145
RJ-11 (modem)	146
RJ-45 (network)	146
Universal Serial Bus	147

11 Power cord set requirements

Requirements for all countries and regions	148
Requirements for specific countries and regions	149

12 Recycling

Battery	150
Display	150

Index	156
--------------------	------------

1 Product description

Category	Description	Computer models equipped with discrete graphics subsystem memory	Computer models equipped with Unified Memory Architecture (UMA) graphics subsystem memory
Product Name	HP EliteBook 6930p Notebook PC	√	√
Processors	Intel® Core™ 2 Duo processors		
	<ul style="list-style-type: none"> T9600 2.80-GHz processor, 6-MB L2 cache, 1066-MHz front side bus (FSB) 	√	√
	<ul style="list-style-type: none"> T9400 2.53-GHz processor, 6-MB L2 cache, 1066-MHz FSB 	√	√
	<ul style="list-style-type: none"> P8600 2.40-GHz processor, 3-MB L2 cache, 1066-MHz FSB 	√	√
	<ul style="list-style-type: none"> P8400 2.26-GHz processor, 3-MB L2 cache, 1066-MHz FSB 	√	√
Chipset	Northbridge: Intel GM45 with up to 1067 FSB with iAMT support	√	
	Northbridge: Intel PM45 with up to 1067 FSB with iAMT support		√
	Southbridge: Intel ICH9M enhanced	√	√
Graphics	ATI M82-SCE Mobility Radeon HD 3450 discrete graphics subsystem memory with 128 MB GDDR3 (operating at 700 MHz) or 256 MB GDDR3 (operating at 700 MHz)	√	
	Mobile Intel GMA X4500 HD Universal Memory Architecture (UMA) graphics subsystem integrated with shared video memory (dynamically allocated), up to 384 MB		√
Panels	All display assemblies include 3 wireless local area network (WLAN) antennae	√	√
	Supports HP Panel Protection System	√	√
	Supports HP privacy filter	√	√
	Supports the following display assemblies:		
	<ul style="list-style-type: none"> 14.1-inch WXGA LED 	√	√

Category	Description	Computer models equipped with discrete graphics subsystem memory	Computer models equipped with Unified Memory Architecture (UMA) graphics subsystem memory
	<ul style="list-style-type: none"> 14.1-inch WXGA+ 	√	√
	<ul style="list-style-type: none"> 14.1-inch WXGA 	√	√
Memory	2 customer-accessible/upgradable memory module slots	√	√
	Supports dual-channel memory	√	√
	Supports up to 8 GB of system RAM	√	√
	PC2-6400, 800-MHz, DDR2	√	√
	Supports the following configurations in all countries and regions except Brazil: <ul style="list-style-type: none"> 8192-MB total system memory (4096 × 2, dual-channel) 4096-MB total system memory (2048 × 2, dual-channel) 4096-MB total system memory (4096 × 1) 3072-MB total system memory (2048 + 1024, dual-channel) 2048-MB total system memory (1024 × 2) 2048-MB total system memory (2048 × 1) 1024-MB total system memory (512 × 2, dual-channel) 1024-MB total system memory (1024 × 1) 	√	√
	Supports the following configurations only in Brazil: <ul style="list-style-type: none"> 4096-MB total system memory (2048 × 2, dual-channel) 2048-MB total system memory (1024 × 2, dual-channel) 2048-MB total system memory (2048 × 1) 1024-MB total system memory (512 × 2, dual-channel) 1024-MB total system memory (1024 × 1) 	√	√
Hard drives	Supports 9.5-mm (2.5-inch) hard drives	√	√
	Customer-accessible	√	√

Category	Description	Computer models equipped with discrete graphics subsystem memory	Computer models equipped with Unified Memory Architecture (UMA) graphics subsystem memory
	Serial ATA	√	√
	Supports Disk Sanitizer	√	√
	Supports full disk encryption	√	√
	Supports HP 3D DriveGuard	√	√
	Supports RAID 0 (striping) and RAID 1 (mirror)	√	√
	Supports the following drives:	√	√
	<ul style="list-style-type: none"> • 250-GB, 5400-rpm hard drive • 160-GB, 7200-rpm hard drive • 160-GB, 5400-rpm hard drive • 120-GB, 7200-rpm hard drive • 120-GB, 5400-rpm hard drive • 80-GB solid-state drive 		
Upgrade bay	Fixed (removal of 1 screw required)	√	√
	Customer-accessible	√	√
	Serial ATA	√	√
	12.7-mm tray load	√	√
	Supports weight saver option	√	√
	Supports the following optical drives:	√	√
	<ul style="list-style-type: none"> • DVD±RW and CD-RW SuperMulti Double-Layer Combo Drive with LightScribe • DVD±RW and CD-RW SuperMulti Double-Layer Combo Drive • DVD/CD-RW Combo Drive • DVD-ROM Drive 		
	Supports the following hard drives (requires the upgrade bay cradle):	√	√
	<ul style="list-style-type: none"> • 250-GB, 5400-rpm • 160-GB, 7200-rpm 		
Audio/video	HD audio	√	√
	Integrated dual array microphones (2)	√	√
	Stereo speakers (2)	√	√
	Integrated 2-megapixel webcam	√	√

Category	Description	Computer models equipped with discrete graphics subsystem memory	Computer models equipped with Unified Memory Architecture (UMA) graphics subsystem memory
Modem	56K V.92 1.5-inch data/fax modem	√	√
	Support for no-modem option	√	√
Ethernet	Intel 82567LM 10/100/1000 Ethernet, with iAMT Intel 82567LM Gigabit network connection	√	√
	S4/S5 wake on LAN: DC - no	√	√
	S4/S5 wake on LAN: AC - yes	√	√
Wireless	Integrated WLAN options by way of wireless module:		
	3 WLAN antennae built into display assembly	√	√
	Support for no-WLAN option	√	√
	Support for the following WLAN formats:	√	√
	<ul style="list-style-type: none"> • Broadcom 4322 802.11a/b/g/n • Broadcom 4311AG 802.11a/b/g • Broadcom BCM4312 802.11b/g • Intel Wi-Fi Link 5300 802.11a/b/g/n • Intel Wi-Fi Link 5100 802.11a/b/g/n • Intel Wi-Fi Link 5100 802.11b/g 		
	Integrated WWAN options by way of wireless module:		
	2 WWAN antennae built into display assembly	√	√
	Subscriber identity module (SIM) security	√	√
	Integrated personal area network (PAN) options by way of Bluetooth® module:		
	Support for no-WPAN option	√	√
Broadcom Bluetooth 2.0+EDR	√	√	
External media cards	One ExpressCard/54 slot	√	√
	SD card reader supporting Secure Digital (SD) Memory Card and MultiMediaCard (MMC)	√	√
Ports	Audio-in (mono microphone)	√	√
	Audio-out (stereo headphone)	√	√
	Docking	√	√
	Battery (system)	√	√

Category	Description	Computer models equipped with discrete graphics subsystem memory	Computer models equipped with Unified Memory Architecture (UMA) graphics subsystem memory
	Battery (travel)	√	√
	RJ-11 (modem)	√	√
	RJ-45 (Ethernet, includes link and activity lights)	√	√
	USB (3)	√	√
	VGA (Dsub 15-pin) supporting 1600 × 1200 external resolution at 75-GHz (hot plug/unplug with auto-detect)	√	√
	1394a	√	√
	3-pin HP Smart AC Adapter	√	√
Keyboard/ pointing devices	11.97-inch keyboard with embedded numeric keypad	√	√
	Spill-resistant keyboard	√	√
	Dura-Keys	√	√
	Vertical scrolling, taps enabled as default	√	√
	Dualpoint (pointing stick and TouchPad) with 2 pointing stick buttons and 2 TouchPad buttons	√	√
Power requirements	90-W HP Smart AC Adapter with localized cable plug support (2-wire plug with ground pin, supports 2-pin DC connector)	√	√
	6-cell, 55-Wh Li-ion battery	√	√
	4-cell, 37-Wh Li-ion battery	√	√
	Support for 12-cell Ultra Capacity Battery	√	√
	Support for 8-cell Li-ion Extended Life Battery	√	√
	HP Fast Charge Technology	√	√
Security	Supports Kensington security sock	√	√
	Infineon Trusted Platform Module (TPM) v. 1.2	√	√
	TPM Enhanced Drive Lock	√	√
	Fingerprint reader	√	√
	Integrated smart card reader	√	√
Operating system	Preinstalled:		

Category	Description	Computer models equipped with discrete graphics subsystem memory	Computer models equipped with Unified Memory Architecture (UMA) graphics subsystem memory
	Windows® Vista® Basic 32 with and without Office Ready	√	√
	Windows Vista Business 32 with and without Office Ready	√	√
	Windows Vista Ultimate with Office Ready (in Canada and the United States)	√	√
	Windows Vista Business with Windows® XP Pro with and without Office Ready	√	√
	Windows Vista Basic 32 with Office Personal and Powerpoint (Japan)	√	√
	Windows Vista Basic 32 with Office Pro 2007 (Japan)	√	√
	Windows Vista Business 32 with Office Personal and Powerpoint (Japan)	√	√
	Windows Vista Business 32 with Office Pro 2007 (Japan)	√	√
	Windows Vista Business 32 with Office Personal (Japan)	√	√
	Windows Vista Business with Windows XP Pro and Office Personal with Powerpoint (Japan)	√	√
	Windows Vista Business with Windows XP Pro and Office Pro 2007 (Japan)	√	√
	Windows Vista Business with Windows XP Pro with Office Personal (Japan)	√	√
	FreeDOS	√	√
	Restore media:		
	DRDVD Windows Vista	√	√
	DRDVD Windows XP	√	√
	Windows Vista Basic 32	√	√
	Windows Vista Business 32	√	√
	Windows Vista Business 64	√	√
	Windows Vista Ultimate	√	√
	Windows XP Pro	√	√
	Certified:		
	Microsoft® WHQL	√	√
	Novell	√	√

Category	Description	Computer models equipped with discrete graphics subsystem memory	Computer models equipped with Unified Memory Architecture (UMA) graphics subsystem memory
	SuSE Linux	√	√
	Web support:		
	Windows Vista Enterprise 32	√	√
	Windows Vista Enterprise 64	√	√
	Windows XP Pro	√	√
Serviceability	Customer service replaceable (CSR) parts:		
	AC adapter	√	√
	Battery (system)	√	√
	Expansion memory module	√	√
	Hard drive	√	√
	Keyboard	√	√
	Optical drive	√	√
	Primary memory module	√	√
	SIM	√	√
	WLAN module	√	√
	WWAN module	√	√

2 External component identification

Top components

Display

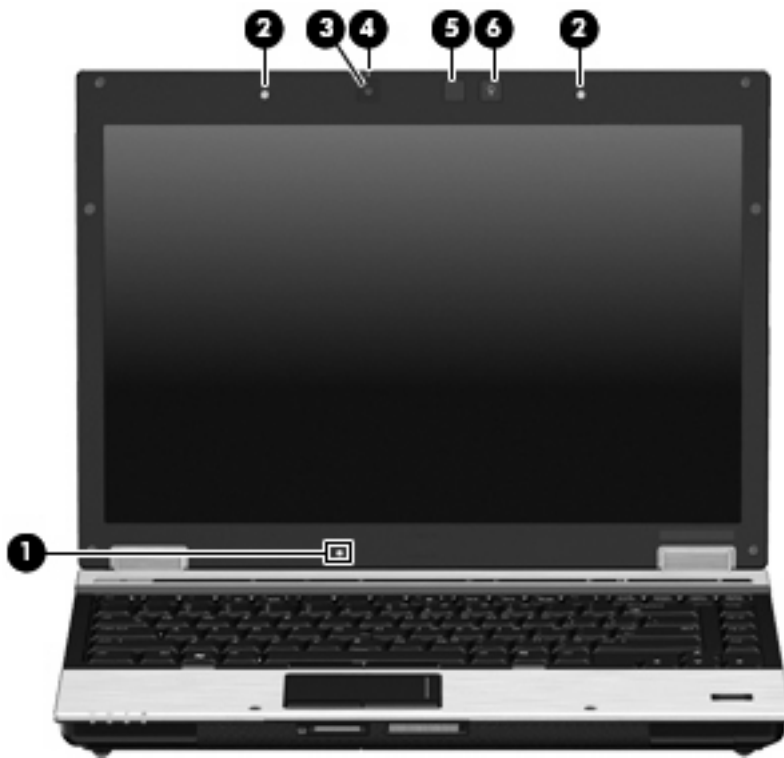

Item	Component	Function
(1)	Ambient light sensor	Automatically adjusts the display brightness based on the lighting conditions in your environment.
(2)	Internal microphones (2)	Record sound.
(3)	HP Webcam	Records video and captures still video.
(4)	HP Webcam light	On: The integrated camera is in use.
(5)	Keyboard light	Illuminates the keyboard in low-light conditions when the keyboard light button is pressed.
(6)	Keyboard light button	Opens and turns on the keyboard light.

Antennae

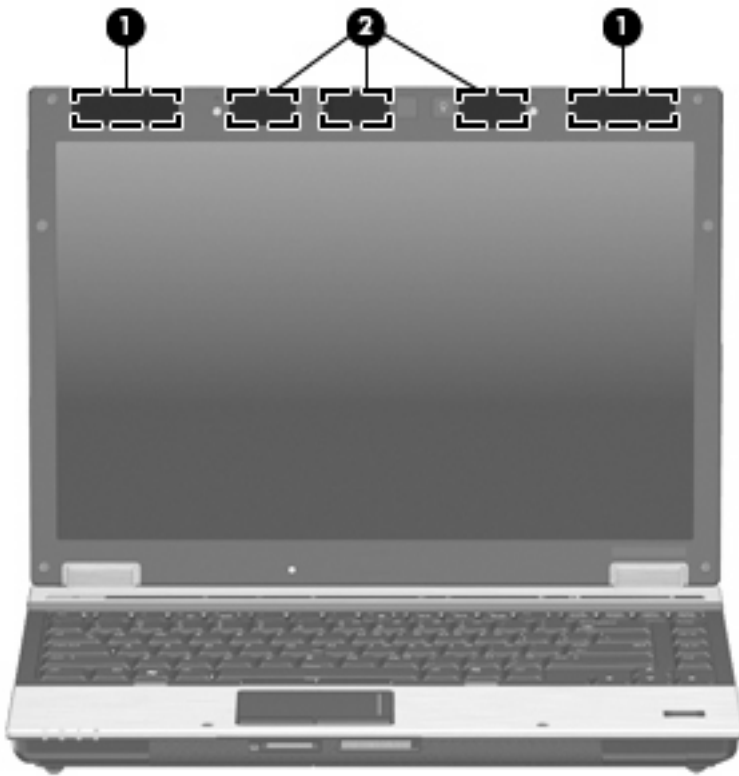

Item	Component	Description
(1)	WWAN antennae (2)*	Send and receive wireless signals to communicate with wireless wide-area networks (WWAN).
(2)	WLAN antennae (3)*	Send and receive wireless signals to communicate with wireless local area networks (WLAN).

*The antennae are not visible from the outside of the computer. For optimal transmission, keep the areas immediately around the antennae free from obstructions.

Button, switches, and fingerprint reader



Item	Component	Function
(1)	Power button	<ul style="list-style-type: none"> When the computer is off, press the button to turn on the computer. When the computer is on, press the button to shut down the computer. When the computer is in the Sleep state, press the button briefly to exit Sleep. When the computer is in Hibernation, press the button briefly to exit Hibernation. <p>If the computer has stopped responding and Windows® shutdown procedures are ineffective, press and hold the power button for at least 5 seconds to turn off the computer.</p> <p>To learn more about your power settings, select Start > Control Panel > System and Maintenance > Power Options.</p>
(2)	Internal display switch	Turns off the display if the display is closed while the power is on.
(3)	Info button	Launches Info center, which enables you to open various software solutions.
(4)	Wireless button	Turns the wireless feature on or off but does not establish a wireless connection.
		NOTE: A wireless network must be set up in order to establish a wireless connection.
(5)	Presentation button	Starts the presentation feature.
(6)	Volume mute button	Mutes and restores speaker sound.

Item	Component	Function
(7)	Volume scroll zone	Adjusts speaker volume. Slide your finger to the left to decrease volume and to the right to increase volume. You can also press the left side of the volume slider to decrease volume, or press the right side of the volume slider to increase volume.
(8)	Fingerprint reader (select models only)	Allows a fingerprint logon to Windows, instead of a password logon.

Keys

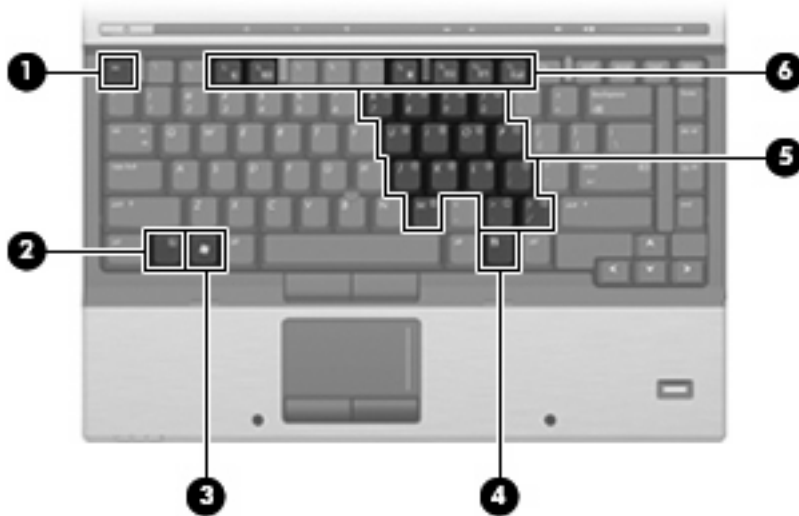

Item	Component	Function
(1)	<code>esc</code> key	Displays system information when pressed in combination with the <code>fn</code> key.
(2)	<code>fn</code> key	Executes frequently used system functions when pressed in combination with a function key or the <code>esc</code> key.
(3)	Windows logo key	Displays the Windows Start menu.
(4)	Windows applications key	Displays a shortcut menu for items beneath the pointer.
(5)	Embedded numeric keypad keys	Can be used like the keys on an external numeric keypad.
(6)	Function keys	Execute frequently used system functions when pressed in combination with the <code>fn</code> key.

Lights



Item	Component	Function
(1)	Wireless lights (2)*	<ul style="list-style-type: none"> On: An integrated wireless device, such as a wireless local area network (WLAN) device, the HP Broadband Wireless Module, and/or a Bluetooth® device, is on. Amber: All wireless devices are off.
(2)	Power lights (2)†	<ul style="list-style-type: none"> On: The computer is on. Blinking: The computer is in the Sleep state. Blinking rapidly: An AC adapter with a higher power rating should be connected. Off: The computer is off or in Hibernation.
(3)	Battery light	<ul style="list-style-type: none"> Amber: A battery is charging. Green: A battery is close to full charge capacity. Blinking amber: A battery that is the only available power source has reached a low battery level. When the battery reaches a critical battery level, the battery light begins blinking rapidly. Off: If the computer is plugged into an external power source, the light turns off when all batteries in the computer are fully charged. If the computer is not plugged into an external power source, the light stays off until the battery reaches a low battery level.
(4)	Drive light	<ul style="list-style-type: none"> Blinking green: The hard drive or optical drive is being accessed. Amber: HP 3D DriveGuard has temporarily parked the internal hard drive, and if present, the hard drive in the upgrade bay.
(5)	Caps lock light	On: Caps lock is on.

Item	Component	Function
(6)	Num lock light	On: Num lock is on or the embedded numeric keypad is enabled.
(7)	Volume mute light	<ul style="list-style-type: none"> On: Computer sound is on. Amber: Computer sound is off.
(8)	Volume down light	Blinking: The volume scroll zone is being used to decrease speaker volume.
(9)	Volume up light	Blinking: The volume scroll zone is being used to increase speaker volume.

*The 2 wireless lights display the same information. The light on the wireless button is visible only when the computer is open. The wireless light on the front of the computer is visible whether the computer is open or closed.

†The 2 power lights display the same information. The light on the power button is visible only when the computer is open. The power light on the front of the computer is visible whether the computer is open or closed.

Pointing devices



Item	Component	Function
(1)	Pointing stick	Moves the pointer and selects or activates items on the screen.
(2)	Left pointing stick button*	Functions like the left button on an external mouse.
(3)	TouchPad*	Moves the pointer and selects or activates items on the screen.
(4)	Left TouchPad button*	Functions like the left button on an external mouse.
(5)	Right pointing stick button*	Functions like the right button on an external mouse.
(6)	TouchPad scroll zone	Scrolls up or down.
(7)	Right TouchPad button*	Functions like the right button on an external mouse.

*This table describes factory settings. To view or change pointing device preferences, select **Start > Control Panel > Hardware and Sound > Mouse**.

Front components

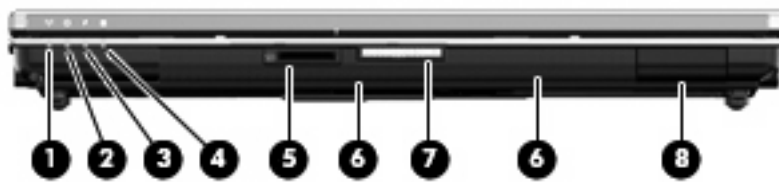

Item	Component	Function
(1)	Wireless light	On: An integrated wireless device, such as a wireless local area network (WLAN) device, the HP Broadband Wireless Module, and/ or a Bluetooth device, is on. Amber: All wireless devices are off.
(2)	Power light	<ul style="list-style-type: none"> On: The computer is on. Blinking: The computer is in the Sleep state. Blinking rapidly: An AC adapter with a higher power rating should be connected. Off: The computer is off or in Hibernation.
(3)	Battery light	<ul style="list-style-type: none"> Amber: A battery is charging. Green: A battery is close to full charge capacity. Blinking amber: A battery that is the only available power source has reached a low battery level. When the battery reaches a critical battery level, the battery light begins blinking rapidly. Off: If the computer is plugged into an external power source, the light turns off when all batteries in the computer are fully charged. If the computer is not plugged into an external power source, the light stays off until the battery reaches a low battery level.
(4)	Drive light	Blinking green: The hard drive or optical drive is being accessed. Amber: HP 3D DriveGuard has temporarily parked the hard drive.
(5)	SD card reader	Supports the Secure Digital (SD) Memory Card and MultiMediaCard (MMC) optional digital card formats.
(6)	Speakers (2)	Produce sound.
(7)	Display release button	Opens the computer.
(8)	Bluetooth compartment	Contains a Bluetooth device.

Rear components



Item	Component	Description
(1)	Security cable slot	Attaches an optional security cable to the computer. NOTE: The security cable is designed to act as a deterrent, but it may not prevent the computer from being mishandled or stolen.
(2)	Power connector	Connects an AC adapter.
(3)	External monitor port	Connects an external VGA monitor or projector.

Right-side components



Item	Component	Function
(1)	Smart card reader	Supports optional smart cards and Java™ cards.
(2)	Upgrade bay	Supports an optical drive or hard drive.
(3)	USB port	Connects an optional USB device.
(4)	RJ-45 (network) jack	Connects a network cable.
(5)	RJ-11 (modem) jack	Connects a modem cable.

Left-side components



Item	Component	Function
(1)	Vent	Enables airflow to cool internal components. NOTE: The computer fan starts up automatically to cool internal components and prevent overheating. It is normal for the internal fan to cycle on and off during routine operation.
(2)	USB ports (2)	Connect optional USB devices.
(3)	1394 port	Connects an optional IEEE 1394 or 1394a device, such as a camcorder.
(4)	Audio-in (microphone) jack	Connects an optional computer headset microphone, stereo array microphone, or monaural microphone.
(5)	Audio-out (headphone) jack	Produces sound when connected to optional powered stereo speakers, headphones, ear buds, a headset, or television audio.
(6)	ExpressCard slot	Supports optional ExpressCards.

Bottom components

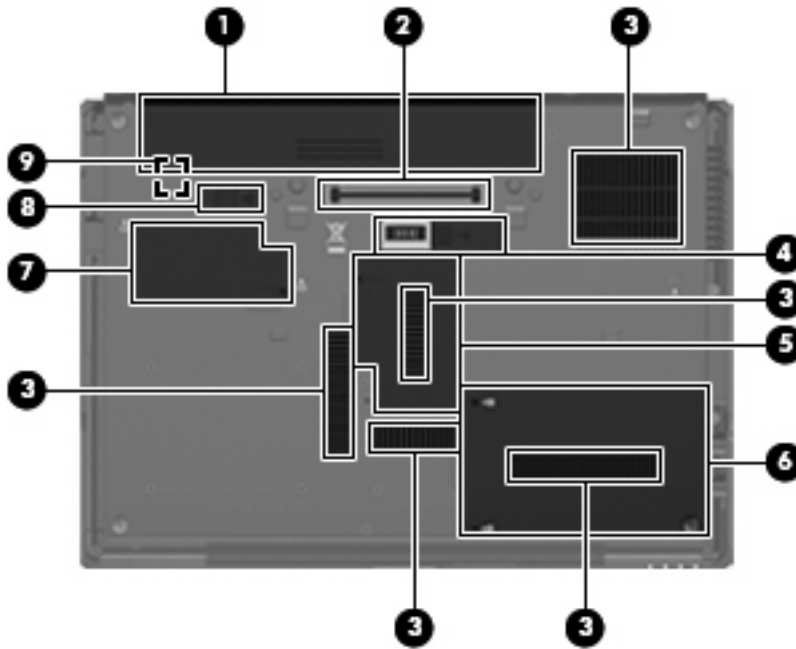

Item	Component	Function
(1)	Battery bay	Holds the battery.
(2)	Docking connector	Connects an optional docking device.
(3)	Vents (5)	Enable airflow to cool internal components. CAUTION: To prevent overheating, do not obstruct vents. Use the computer only on a hard, flat surface. Do not allow another hard surface, such as an adjoining optional printer, or a soft surface, such as pillows or thick rugs or clothing, to block airflow. NOTE: The computer fan starts up automatically to cool internal components and prevent overheating. It is normal for the internal fan to cycle on and off during routine operation.
(4)	Accessory battery connector	Connects an optional accessory battery.
(5)	Memory module compartment	Contains the expansion memory module slot.
(6)	Hard drive bay	Holds the hard drive.
(7)	WWAN module compartment	Contains a WWAN module (select models only). CAUTION: To prevent an unresponsive system and the display of a warning message, replace the device with only a WLAN module authorized for use in the computer by the governmental agency that regulates wireless devices in your country. If you replace the device and then receive a warning message, remove the device to restore computer functionality, and then contact technical support through Help and Support.
(8)	Battery release latch	Releases the battery from the battery bay.
(9)	SIM slot (select models only)	Contains a wireless subscriber identity module (SIM). The SIM slot is located inside the battery bay.

3 Illustrated parts catalog

Serial number location

The service tag, affixed to the bottom of the computer, provides information that may be needed when troubleshooting system problems. The service tag provides the following information:

- (1) Product name: This is the product name affixed to the front of the computer.
- (2) Serial number (s/n): This is an alphanumeric identifier that is unique to each product.
- (3) Part number/Product number (p/n): This number provides specific information about the product's hardware components. The part number helps a service technician to determine what components and parts are needed.
- (4) Model description: This is the number used to locate documents, drivers, and support for the computer.
- (5) Warranty period: Describes the duration of the warranty period for the computer.

When ordering parts or requesting information, provide the computer serial number and model description provided on the service tag.

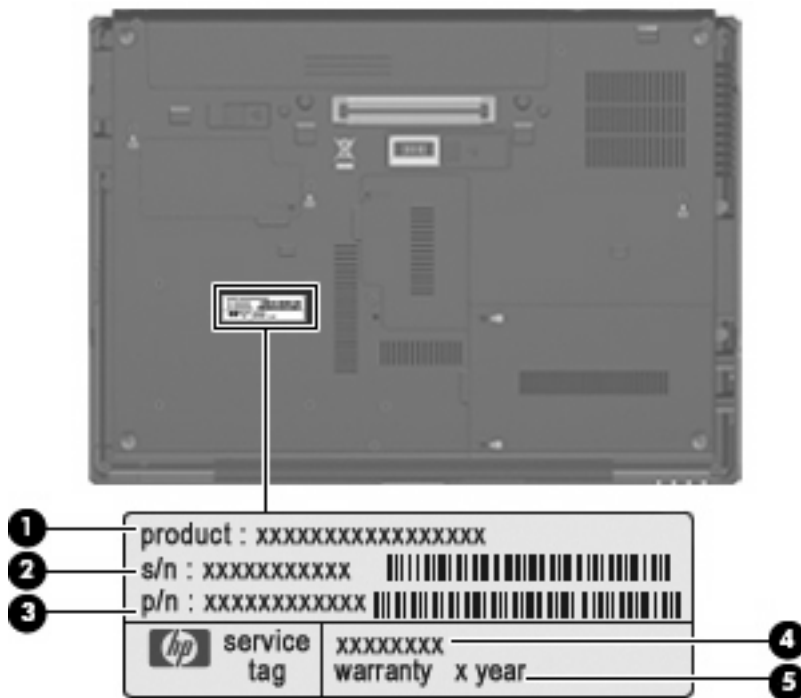

Computer major components

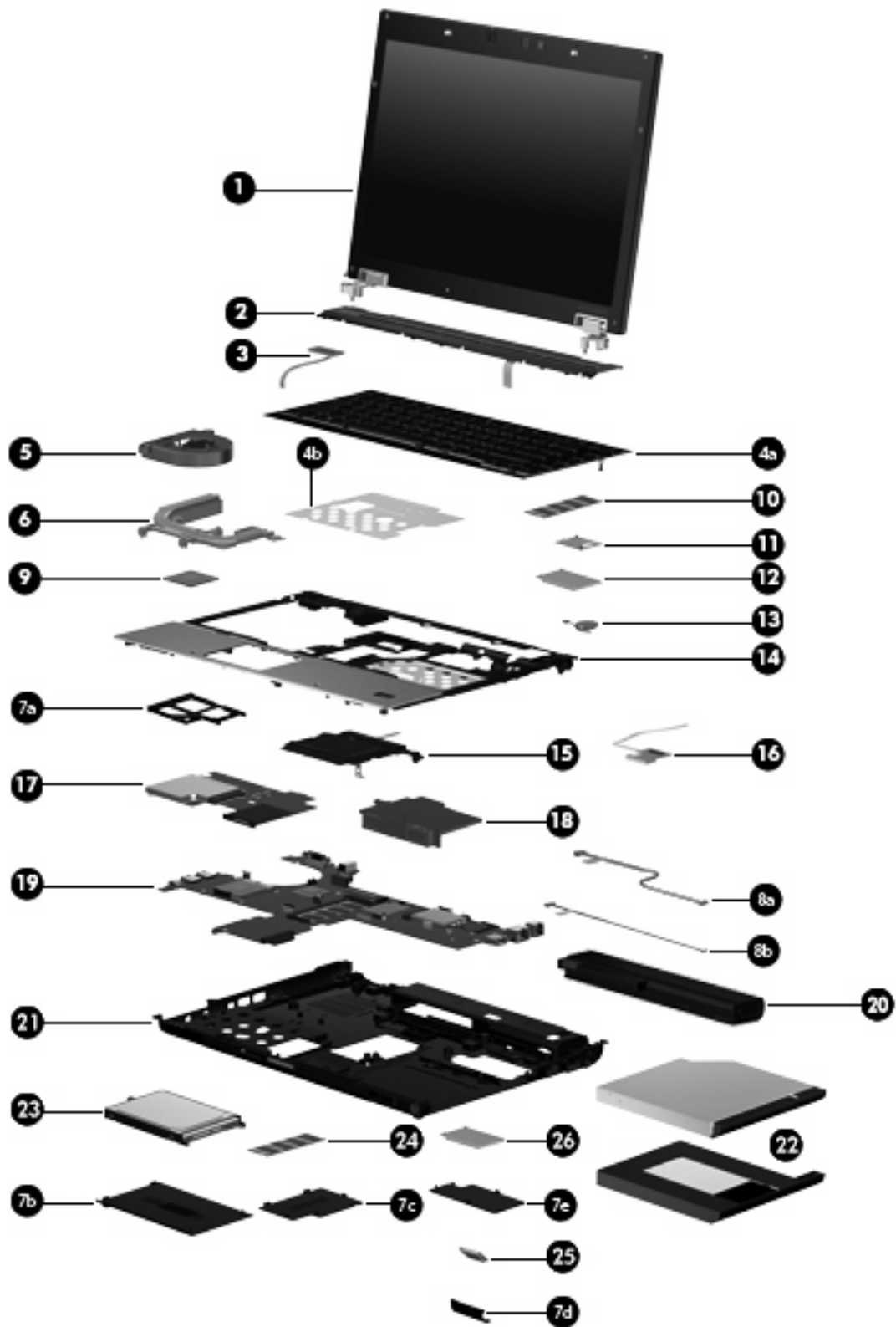

Item	Description	Spare part number
(1)	14.1-inch, AntiGlare display assemblies (include three WLAN antenna cables, two WWAN antenna cables, and two microphones):	
	WXGA LED display assembly with webcam (includes webcam cable)	487433-001
	WXGA LED display assembly without webcam	483202-001
	WXGA+ display assembly with webcam (includes webcam cable)	487435-001
	WXGA+ display assembly without webcam	483201-001
	WXGA display assembly with webcam (includes webcam cable)	487434-001
	WXGA display assembly without webcam	483200-001
	Display assembly internal components:	
	Display bezels	
	For use only with computer models equipped with a webcam	488189-001
	For use only with computer models not equipped with a webcam	488190-001
	Webcam	486302-001
	Display inverter	487431-001
	Display Hinge Kit (includes left and right hinges)	482967-001
	Display Cable Kit (includes display panel cable)	482966-001
	Logo Kit	500325-001
	Wireless Antenna Kit (includes 3 WLAN antenna transceivers and cables and 2 WWAN antenna transceivers and cables)	482969-001
(2)	Switch cover (includes capacitive board and cable)	486307-001
(3)	Power button board (includes cable)	482964-001
(4a)	Keyboards (include keyboard cable, keyboard shield, pointing stick, and pointing stick cable)	
	For use in Belgium	483010-A41
	For use in Brazil	483010-201
	For use in the Czech Republic	483010-221
	For use in Denmark	483010-081
	For use in France	483010-051
	For use in French Canada	483010-121
	For use in Germany	483010-041
	For use in Greece	483010-DJ1
	For use in Hungary	483010-211
	For use in Iceland	483010-DD1
	For use in Israel	483010-BB1
	For use in Italy	483010-061
	For use in Japan	483010-291

Item	Description	Spare part number
	For use in Latin America	483010-161
	For use in the Netherlands	483010-B31
	For use in Norway	483010-091
	For use in Portugal	483010-131
	For use in Russia	483010-251
	For use in Saudi Arabia	483010-171
	For use in Sweden and Finland	483010-B71
	For use in Slovakia	483010-231
	For use in South Korea	483010-AD1
	For use in Spain	483010-071
	For use in Switzerland	483010-BG1
	For use in Taiwan	483010-AB1
	For use in Turkey	483010-141
	For use in the United Kingdom	483010-031
	For use in the United States	483010-001
(4b)	Keyboard shield (included with keyboard spare part kit)	
	Pointing stick rubber caps (not illustrated)	486565-001
(5)	Fan	487436-001
(6)	Heat sinks (include replacement thermal material)	
	For use only with computer models with discrete graphics subsystem memory	483011-001
	For use only with computer models with UMA graphics subsystem memory	483012-001
	Plastics Kit (see Plastics Kit on page 25 for more Plastics Kit spare part information):	487429-001
(7a)	ExpressCard slot bezel	
(7b)	Hard drive bay cover	
(7c)	Memory module compartment cover	
(7d)	Bluetooth module compartment cover	
(7e)	WWAN module compartment cover	
	Cable Kit:	487432-001
(8a)	Bluetooth module cable	
(8b)	Modem module cable (includes RJ-11 connector)	
(9)	Intel Core 2 Duo processors (include replacement thermal material)	
	T9600 2.80-GHz (1066-MHz FSB, 6-MB L2 cache)	483199-001
	T9400 2.53-GHz (1066-MHz FSB, 6-MB L2 cache)	483198-001
	P8600 2.40-GHz (1066-MHz FSB, 3-MB L2 cache)	483197-001

Item	Description	Spare part number
	P8400 2.26-GHz (1066-MHz FSB, 3-MB L2 cache)	483196-001
(10)	Primary memory modules (PC2-6400, 667-MHz, DDR2)	
	4096-MB	483195-001
	2048-MB	483194-001
	1024-MB	483193-001
(11)	Modem modules	
	NOTE: The modem module spare part kits do not include a modem module cable. The modem module cable is included in the Cable Kit, spare part number 487432-001. See Cable Kit on page 26 for more Cable Kit spare part information.	
	For use in all countries and regions except Australia and New Zealand	461750-001
	For use only in Australia and New Zealand	461750-011
(12)	WLAN modules	
	Intel Wi-Fi Link 5300 802.11a/b/g/n WLAN module for use in all countries and regions	480986-001
	Intel Wi-Fi Link 5100 802.11a/b/g/n WLAN module for use in all countries and regions	480985-001
	Intel Wi-Fi Link 5100 802.11a/b/g WLAN module for use in all countries and regions	482957-001
	Broadcom 4322 802.11a/b/g/n WLAN modules:	
	<ul style="list-style-type: none"> For use in Antigua and Barbuda, Barbados, Belize, Canada, the Cayman Islands, Guam, Puerto Rico, Trinidad and Tobago, the U.S. Virgin Islands, and the United States 	487330-001
	<ul style="list-style-type: none"> For use in Afghanistan, Albania, Algeria, Andorra, Angola, Antigua and Barbuda, Argentina, Armenia, Aruba, Australia, Austria, Azerbaijan, the Bahamas, Bahrain, Bangladesh, Barbados, Belarus, Belgium, Belize, Benin, Bermuda, Bhutan, Bolivia, Bosnia and Herzegovina, Botswana, Brazil, the British Virgin Islands, Brunei, Bulgaria, Burkina Faso, Burundi, Cameroon, Cape Verde, the Central African Republic, Chad, Chile, the People's Republic of China, Colombia, Comoros, the Congo, Costa Rica, Croatia, Cyprus, the Czech Republic, Denmark, Djibouti, Dominica, the Dominican Republic, East Timor, Ecuador, Egypt, El Salvador, Equatorial Guinea, Eritrea, Estonia, Ethiopia, Fiji, Finland, France, French Guiana, Gabon, Gambia, Georgia, Germany, Ghana, Gibraltar, Greece, Grenada, Guadeloupe, Guatemala, Guinea, Guinea-Bissau, Guyana, Haiti, Honduras, Hong Kong, Hungary, Iceland, India, Ireland, Israel, Italy, the Ivory Coast, Jamaica, Jordan, Kazakhstan, Kenya, Kiribati, Kyrgyzstan, Laos, Latvia, Lebanon, Lesotho, Liberia, Liechtenstein, Lithuania, Luxembourg, Macedonia, Madagascar, Malawi, Malaysia, the Maldives, Mali, Malta, the Marshall Islands, Martinique, Mauritania, Mauritius, Mexico, Micronesia, Monaco, Mongolia, Montenegro, Morocco, Mozambique, Namibia, Nauru, Nepal, the Nether Antilles, the Netherlands, New Zealand, Nicaragua, Niger, Nigeria, Norway, Oman, Pakistan, Palau, Panama, Papua New Guinea, Paraguay, Peru, the Philippines, Poland, Portugal, the Republic of Moldova, Romania, Russia, Rwanda, Samoa, San Marino, Sao Tome and Principe, Saudi Arabia, Senegal, Serbia, the Seychelles, Sierra Leone, Singapore, Slovakia, Slovenia, the Solomon Islands, Somalia, South Africa, South Korea, Spain, Sri Lanka, St. Kitts and Nevis, St. Lucia, St. Vincent and the Grenadines, Suriname, Swaziland, Sweden, Switzerland, Taiwan, Tajikistan, Tanzania, Togo, Tonga, Trinidad and Tobago, Tunisia, Turkey, Turkmenistan, Tuvalu, Uganda, Ukraine, the United Arab Emirates, the United Kingdom, Uruguay, Uzbekistan, Vanuatu, Venezuela, Vietnam, Yemen, Zaire, Zambia, and Zimbabwe 	487330-002

Item	Description	Spare part number
Broadcom BCM4312 802.11b/g WLAN modules:		
	<ul style="list-style-type: none"> For use in Antigua and Barbuda, Barbados, Belize, Canada, the Cayman Islands, Guam, Puerto Rico, Trinidad and Tobago, the U.S. Virgin Islands, and the United States 	459263-001
	<ul style="list-style-type: none"> For use in Afghanistan, Albania, Algeria, Andorra, Angola, Antigua and Barbuda, Argentina, Armenia, Aruba, Australia, Austria, Azerbaijan, the Bahamas, Bahrain, Bangladesh, Barbados, Belarus, Belgium, Belize, Benin, Bermuda, Bhutan, Bolivia, Bosnia and Herzegovina, Botswana, Brazil, the British Virgin Islands, Brunei, Bulgaria, Burkina Faso, Burundi, Cameroon, Cape Verde, the Central African Republic, Chad, Chile, the People's Republic of China, Colombia, Comoros, the Congo, Costa Rica, Croatia, Cyprus, the Czech Republic, Denmark, Djibouti, Dominica, the Dominican Republic, East Timor, Ecuador, Egypt, El Salvador, Equatorial Guinea, Eritrea, Estonia, Ethiopia, Fiji, Finland, France, French Guiana, Gabon, Gambia, Georgia, Germany, Ghana, Gibraltar, Greece, Grenada, Guadeloupe, Guatemala, Guinea, Guinea-Bissau, Guyana, Haiti, Honduras, Hong Kong, Hungary, Iceland, India, Ireland, Israel, Italy, the Ivory Coast, Jamaica, Jordan, Kazakhstan, Kenya, Kiribati, Kyrgyzstan, Laos, Latvia, Lebanon, Lesotho, Liberia, Liechtenstein, Lithuania, Luxembourg, Macedonia, Madagascar, Malawi, Malaysia, the Maldives, Mali, Malta, the Marshall Islands, Martinique, Mauritania, Mauritius, Mexico, Micronesia, Monaco, Mongolia, Montenegro, Morocco, Mozambique, Namibia, Nauru, Nepal, the Nether Antilles, the Netherlands, New Zealand, Nicaragua, Niger, Nigeria, Norway, Oman, Pakistan, Palau, Panama, Papua New Guinea, Paraguay, Peru, the Philippines, Poland, Portugal, the Republic of Moldova, Romania, Russia, Rwanda, Samoa, San Marino, Sao Tome and Principe, Saudi Arabia, Senegal, Serbia, the Seychelles, Sierra Leone, Singapore, Slovakia, Slovenia, the Solomon Islands, Somalia, South Africa, South Korea, Spain, Sri Lanka, St. Kitts and Nevis, St. Lucia, St. Vincent and the Grenadines, Suriname, Swaziland, Sweden, Switzerland, Taiwan, Tajikistan, Tanzania, Togo, Tonga, Trinidad and Tobago, Tunisia, Turkey, Turkmenistan, Tuvalu, Uganda, Ukraine, the United Arab Emirates, the United Kingdom, Uruguay, Uzbekistan, Vanuatu, Venezuela, Vietnam, Yemen, Zaire, Zambia, and Zimbabwe 	459263-002
(13)	RTC battery	482963-001
(14)	Top cover (includes smart card reader and TouchPad buttons)	486303-001
(15)	TouchPad (includes cable and TouchPad button board and cable)	486306-001
(16)	Fingerprint reader board (includes cable)	486309-001
(17)	Audio/ExpressCard assembly (includes ExpressCard slot, cable, headphone and microphone connectors, and SD card reader slot)	482959-001
(18)	Speaker	486308-001
(19)	System boards (include replacement thermal material)	
	For use only with computer models with discrete graphics subsystem memory (includes 256 MB of graphics subsystem memory)	486300-001
	For use only with computer models with discrete graphics subsystem memory (includes 128 MB of graphics subsystem memory)	486299-001
	For use only with computer models with UMA graphics subsystem memory	486301-001
(20)	Batteries	
	6-cell, 55-Wh Li-ion battery	482962-001
	4-cell, 37-Wh Li-ion battery	482961-001
(21)	Base enclosure	482960-001

Item	Description	Spare part number
	Rubber Kit (not illustrated, includes base enclosure rubber feet and rubber screw covers)	482968-001
(22)	Optical drives (include bezel and bracket)	
	DVD±RW and CD-RW SuperMulti Double-Layer Combo Drive with LightScribe	483190-001
	DVD/CD-RW Combo Drive	483189-001
	DVD-ROM Drive	483191-001
	Upgrade bay device cradle	502332-001
(23)	Hard drives (include bracket)	
	250-GB, 5400-rpm	483187-001
	160-GB, 7200-rpm	483186-001
	160-GB, 5400-rpm	483185-001
	120-GB, 7200-rpm	483184-001
	120-GB, 5400-rpm	483183-001
	80-GB solid-state drive (not illustrated)	486304-001
(24)	External memory modules (PC2-6400, 667-MHz, DDR2)	
	4096-MB	483195-001
	2048-MB	483194-001
	1024-MB	483193-001
(25)	Bluetooth module	483113-001
	NOTE: The Bluetooth module spare part kit does not include a Bluetooth module cable. The Bluetooth module cable is included in the Cable Kit, spare part number 487432-001. See Cable Kit on page 26 for more Cable Kit spare part information.	
(26)	HP un2400 Mobile Broadband WWAN module	483377-001

Plastics Kit

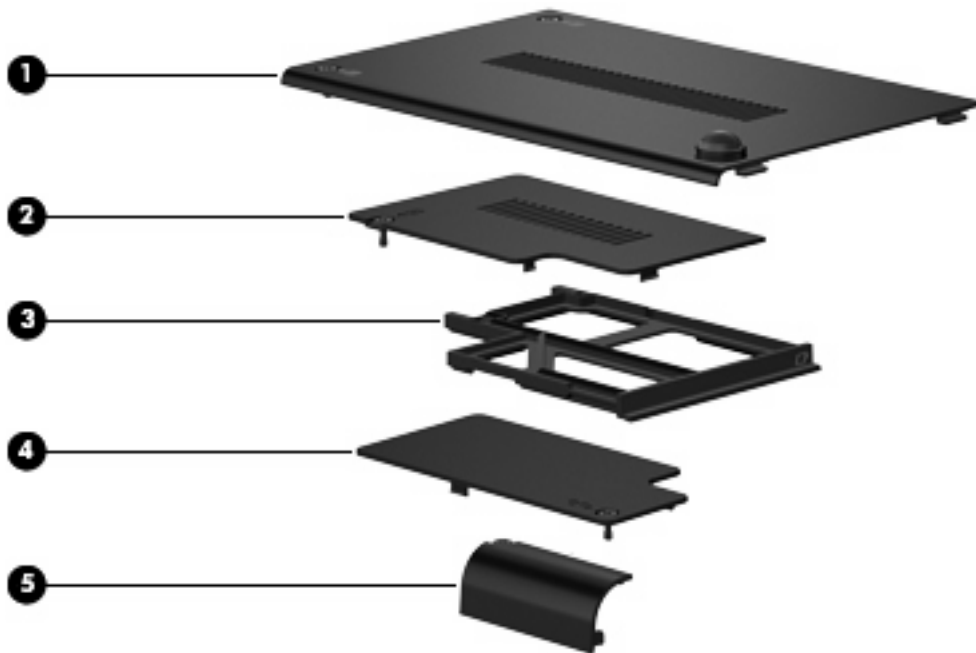

Item	Description	Spare part number
	Plastics Kit:	487429-001
(1)	Hard drive bay cover (includes 2 captive screws, secured by C-clips)	
(2)	Memory module compartment cover (includes one captive screw, secured by a C-clip)	
(3)	ExpressCard slot bezel	
(4)	WWAN module compartment cover (includes one captive screw, secured by a C-clip)	
(5)	Bluetooth module compartment cover (includes one captive screw, secured by a C-clip)	

Cable Kit



Item	Description	Spare part number
	Cable Kit:	487432-001
(1)	Modem module cable (includes RJ-11 connector)	
(2)	Bluetooth module cable	

Mass storage devices

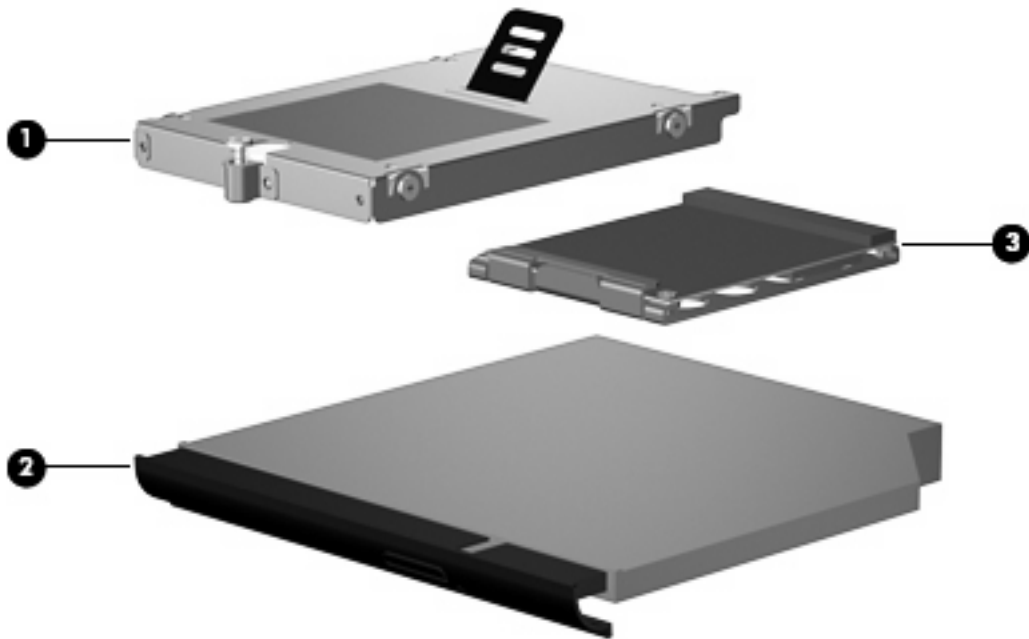

Item	Description	Spare part number
(1)	Hard drives (include bracket)	
	250-GB, 5400-rpm	483187-001
	160-GB, 7200-rpm	483186-001
	160-GB, 5400-rpm	483185-001
	120-GB, 7200-rpm	483184-001
	120-GB, 5400-rpm	483183-001
(2)	Optical drives (include bezel and bracket)	
	DVD±RW and CD-RW SuperMulti Double-Layer Combo Drive with LightScribe	483190-001
	DVD/CD-RW Combo Drive	483189-001
	DVD-ROM Drive	483191-001
	Upgrade bay device cradle	502332-001
(3)	80-GB solid-state drive	486304-001

Miscellaneous parts

Description	Spare part number
AC adapters	
90-W HP Smart AC adapter for use in all countries and regions except India	463955-001
90-W HP Smart AC adapter for use only in India	463956-001
Power cords:	
For use in Argentina	490371-D01
For use in Australia	490371-011
For use in Brazil	490371-201
For use in Iceland	490371-BB1
For use in India	490371-D61
For use in Italy	490371-061
For use in Japan	490371-291
For use in the People's Republic of China	490371-AA1
For use in South Africa	490371-AR1
For use in South Korea	490371-AD1
For use in Switzerland	490371-111
For use in Taiwan	490371-AB1
For use in the United Kingdom	490371-031
For use in the United States	490371-001
Screw Kit	486305-001
<ul style="list-style-type: none"> • Phillips PM3.0×4.0 screw • Phillips PM2.5×11.0 captive screw • Phillips PM2.5×10.0 captive screw • Phillips PM2.5×9.0 captive screw • Phillips PM2.5×7.0 screw • Phillips PM2.5×4.0 screw • Phillips PM2.0×5.0 captive screw • Phillips PM2.0×5.0 screw • Phillips PM2.0×3.0 broad-head screw • Phillips PM2.0×3.0 screw • Torx T8M2.5×7.0 screw 	
Travel battery	456946-001

Sequential part number listing

Spare part number	Description
456946-001	Travel battery
459263-001	Broadcom BCM4312 802.11b/g WLAN module for use in Antigua and Barbuda, Barbados, Belize, Canada, the Cayman Islands, Guam, Puerto Rico, Trinidad and Tobago, the U.S. Virgin Islands, and the United States
459263-002	Broadcom BCM4312 802.11b/g WLAN module for use in Afghanistan, Albania, Algeria, Andorra, Angola, Antigua and Barbuda, Argentina, Armenia, Aruba, Australia, Austria, Azerbaijan, the Bahamas, Bahrain, Bangladesh, Barbados, Belarus, Belgium, Belize, Benin, Bermuda, Bhutan, Bolivia, Bosnia and Herzegovina, Botswana, Brazil, the British Virgin Islands, Brunei, Bulgaria, Burkina Faso, Burundi, Cameroon, Cape Verde, the Central African Republic, Chad, Chile, the People's Republic of China, Colombia, Comoros, the Congo, Costa Rica, Croatia, Cyprus, the Czech Republic, Denmark, Djibouti, Dominica, the Dominican Republic, East Timor, Ecuador, Egypt, El Salvador, Equatorial Guinea, Eritrea, Estonia, Ethiopia, Fiji, Finland, France, French Guiana, Gabon, Gambia, Georgia, Germany, Ghana, Gibraltar, Greece, Grenada, Guadeloupe, Guatemala, Guinea, Guinea-Bissau, Guyana, Haiti, Honduras, Hong Kong, Hungary, Iceland, India, Ireland, Israel, Italy, the Ivory Coast, Jamaica, Jordan, Kazakhstan, Kenya, Kiribati, Kyrgyzstan, Laos, Latvia, Lebanon, Lesotho, Liberia, Liechtenstein, Lithuania, Luxembourg, Macedonia, Madagascar, Malawi, Malaysia, the Maldives, Mali, Malta, the Marshall Islands, Martinique, Mauritania, Mauritius, Mexico, Micronesia, Monaco, Mongolia, Montenegro, Morocco, Mozambique, Namibia, Nauru, Nepal, the Nether Antilles, the Netherlands, New Zealand, Nicaragua, Niger, Nigeria, Norway, Oman, Pakistan, Palau, Panama, Papua New Guinea, Paraguay, Peru, the Philippines, Poland, Portugal, the Republic of Moldova, Romania, Russia, Rwanda, Samoa, San Marino, Sao Tome and Principe, Saudi Arabia, Senegal, Serbia, the Seychelles, Sierra Leone, Singapore, Slovakia, Slovenia, the Solomon Islands, Somalia, South Africa, South Korea, Spain, Sri Lanka, St. Kitts and Nevis, St. Lucia, St. Vincent and the Grenadines, Suriname, Swaziland, Sweden, Switzerland, Taiwan, Tajikistan, Tanzania, Togo, Tonga, Trinidad and Tobago, Tunisia, Turkey, Turkmenistan, Tuvalu, Uganda, Ukraine, the United Arab Emirates, the United Kingdom, Uruguay, Uzbekistan, Vanuatu, Venezuela, Vietnam, Yemen, Zaire, Zambia, and Zimbabwe
461750-001	Modem module for use in all countries and regions except Australia and New Zealand NOTE: The modem module spare part kits do not include a modem module cable. The modem module cable is included in the Cable Kit, spare part number 487432-001. See Cable Kit on page 26 for more Cable Kit spare part information.
461750-011	Modem module for use only in Australia and New Zealand NOTE: The modem module spare part kits do not include a modem module cable. The modem module cable is included in the Cable Kit, spare part number 487432-001. See Cable Kit on page 26 for more Cable Kit spare part information.
463955-001	90-W HP Smart AC adapter for use in all countries and regions except India
463956-001	90-W HP Smart AC adapter for use only in India
480985-001	Intel Wi-Fi Link 5100 802.11a/b/g/n WLAN module for use in all countries and regions
480986-001	Intel Wi-Fi Link 5300 802.11a/b/g/n WLAN module for use in all countries and regions
482957-001	Intel Wi-Fi Link 5100 802.11a/b/g WLAN module for use in all countries and regions
482959-001	Audio/ExpressCard assembly (includes cable)
482960-001	Base enclosure
482961-001	4-cell, 37-Wh Li-ion battery
482962-001	6-cell, 55-Wh Li-ion battery
482963-001	RTC battery

Spare part number	Description
482964-001	Power button board (includes cable)
482966-001	Display Cable Kit (includes display panel cable)
482967-001	Display Hinge Kit (includes left and right hinges)
482968-001	Rubber Kit (includes base enclosure rubber feet, rubber screw covers, and display bezel rubber screw covers)
482969-001	Wireless Antenna Kit (includes 3 WLAN antenna transceivers and cables and 2 WWAN antenna transceivers and cables)
483010-001	Keyboard for use in the United States (includes keyboard cable, keyboard shield, pointing stick, and pointing stick cable)
483010-031	Keyboard for use in the United Kingdom (includes keyboard cable, keyboard shield, pointing stick, and pointing stick cable)
483010-041	Keyboard for use in Germany (includes keyboard cable, keyboard shield, pointing stick, and pointing stick cable)
483010-051	Keyboard for use in France (includes keyboard cable, keyboard shield, pointing stick, and pointing stick cable)
483010-061	Keyboard for use in Italy (includes keyboard cable, keyboard shield, pointing stick, and pointing stick cable)
483010-071	Keyboard for use in Spain (includes keyboard cable, keyboard shield, pointing stick, and pointing stick cable)
483010-081	Keyboard for use in Denmark (includes keyboard cable, keyboard shield, pointing stick, and pointing stick cable)
483010-091	Keyboard for use in Norway (includes keyboard cable, keyboard shield, pointing stick, and pointing stick cable)
483010-121	Keyboard for use in French Canada (includes keyboard cable, keyboard shield, pointing stick, and pointing stick cable)
483010-131	Keyboard for use in Portugal (includes keyboard cable, keyboard shield, pointing stick, and pointing stick cable)
483010-141	Keyboard for use in Turkey (includes keyboard cable, keyboard shield, pointing stick, and pointing stick cable)
483010-161	Keyboard for use in Latin America (includes keyboard cable, keyboard shield, pointing stick, and pointing stick cable)
483010-171	Keyboard for use in Saudi Arabia (includes keyboard cable, keyboard shield, pointing stick, and pointing stick cable)
483010-201	Keyboard for use in Brazil (includes keyboard cable, keyboard shield, pointing stick, and pointing stick cable)
483010-211	Keyboard for use in Hungary (includes keyboard cable, keyboard shield, pointing stick, and pointing stick cable)
483010-221	Keyboard for use in the Czech Republic (includes keyboard cable, keyboard shield, pointing stick, and pointing stick cable)
483010-231	Keyboard for use in Slovakia (includes keyboard cable, keyboard shield, pointing stick, and pointing stick cable)
483010-251	Keyboard for use in Russia (includes keyboard cable, keyboard shield, pointing stick, and pointing stick cable)

Spare part number	Description
483010-281	Keyboard for use in Thailand (includes keyboard cable, keyboard shield, pointing stick, and pointing stick cable)
483010-291	Keyboard for use in Japan (includes keyboard cable, keyboard shield, pointing stick, and pointing stick cable)
483010-A41	Keyboard for use in Belgium (includes keyboard cable, keyboard shield, pointing stick, and pointing stick cable)
483010-AB1	Keyboard for use in Taiwan (includes keyboard cable, keyboard shield, pointing stick, and pointing stick cable)
483010-AD1	Keyboard for use in South Korea (includes keyboard cable, keyboard shield, pointing stick, and pointing stick cable)
483010-B31	Keyboard for use in the Netherlands (includes keyboard cable, keyboard shield, pointing stick, and pointing stick cable)
483010-B71	Keyboard for use in Sweden and Finland (includes keyboard cable, keyboard shield, pointing stick, and pointing stick cable)
483010-BB1	Keyboard for use in Israel (includes keyboard cable, keyboard shield, pointing stick, and pointing stick cable)
483010-BG1	Keyboard for use in Switzerland (includes keyboard cable, keyboard shield, pointing stick, and pointing stick cable)
483010-DD1	Keyboard for use in Iceland (includes keyboard cable, keyboard shield, pointing stick, and pointing stick cable)
483010-DJ1	Keyboard for use in Greece (includes keyboard cable, keyboard shield, pointing stick, and pointing stick cable)
483011-001	Heat sink for use only with computer models with discrete graphics subsystem memory (includes replacement thermal material)
483012-001	Heat sink for use only with computer models with UMA graphics subsystem memory (includes replacement thermal material)
483113-001	Bluetooth module NOTE: The Bluetooth module spare part kit does not include a Bluetooth module cable. The Bluetooth module cable is included in the Cable Kit, spare part number 487432-001. See Cable Kit on page 26 for more Cable Kit spare part information.
483183-001	120-GB, 5400-rpm hard drive (includes bracket)
483184-001	120-GB, 7200-rpm hard drive (includes bracket)
483185-001	160-GB, 5400-rpm hard drive (includes bracket)
483186-001	160-GB, 7200-rpm hard drive (includes bracket)
483187-001	250-GB, 5400-rpm hard drive (includes bracket)
483189-001	DVD/CD-RW Combo Drive
483190-001	DVD±RW and CD-RW SuperMulti Double-Layer Combo Drive with LightScribe
483191-001	DVD-ROM Drive
483193-001	1024-MB memory module (PC2-6400, 667-MHz, DDR2)
483194-001	2048-MB memory module (PC2-6400, 667-MHz, DDR2)

Spare part number	Description
483195-001	4096-MB memory module (PC2-6400, 667-MHz, DDR2)
483196-001	Intel Core 2 Duo 2.26-GHz processor (1066-MHz FSB, 3-MB L2 cache, includes replacement thermal material)
483197-001	Intel Core 2 Duo 2.40-GHz processor (1066-MHz FSB, 3-MB L2 cache, includes replacement thermal material)
483198-001	Intel Core 2 Duo 2.53-GHz processor (1066-MHz FSB, 6-MB L2 cache, includes replacement thermal material)
483199-001	Intel Core 2 Duo 2.80-GHz processor (1066-MHz FSB, 6-MB L2 cache, includes replacement thermal material)
483200-001	14.1-inch, WXGA AntiGlare display assembly for use on computer models not equipped with a webcam (includes three WLAN antenna cables, two WWAN antenna cables, and two microphones)
483201-001	14.1-inch, WXGA+ AntiGlare display assembly for use on computer models not equipped with a webcam (includes three WLAN antenna cables, two WWAN antenna cables, and two microphones)
483202-001	14.1-inch, WXGA AntiGlare LED display assembly for use on computer models not equipped with a webcam (includes three WLAN antenna cables, two WWAN antenna cables, and two microphones)
483377-001	HP un2400 Mobile Broadband WWAN module
486299-001	System board with 128 MB of discrete graphics subsystem memory (includes replacement thermal material)
486300-001	System board with 256 MB of discrete graphics subsystem memory (includes replacement thermal material)
486301-001	System board for use only with computer models with UMA graphics subsystem memory (includes replacement thermal material)
486302-001	Webcam
486303-001	Top cover (includes TouchPad buttons)
486304-001	80-GB solid-state drive
486305-001	Screw Kit
486306-001	TouchPad (includes cable and TouchPad button board and cable)
486307-001	Switch cover (includes capacitive board and cable)
486308-001	Speaker
486309-001	Fingerprint reader board (includes cable)
486565-001	Pointing stick rubber caps
487330-001	Broadcom 4322 802.11a/b/g/n WLAN module for use in Antigua and Barbuda, Barbados, Belize, Canada, the Cayman Islands, Guam, Puerto Rico, Trinidad and Tobago, the U.S. Virgin Islands, and the United States
487330-002	Broadcom 4322 802.11a/b/g/n WLAN module for use in Afghanistan, Albania, Algeria, Andorra, Angola, Antigua and Barbuda, Argentina, Armenia, Aruba, Australia, Austria, Azerbaijan, the Bahamas, Bahrain, Bangladesh, Barbados, Belarus, Belgium, Belize, Benin, Bermuda, Bhutan, Bolivia, Bosnia and Herzegovina, Botswana, Brazil, the British Virgin Islands, Brunei, Bulgaria, Burkina Faso, Burundi, Cameroon, Cape Verde, the Central African Republic, Chad, Chile, the People's Republic of China, Colombia, Comoros, the Congo, Costa Rica, Croatia, Cyprus, the Czech Republic, Denmark, Djibouti, Dominica, the Dominican Republic, East Timor, Ecuador, Egypt, El Salvador, Equatorial Guinea, Eritrea, Estonia, Ethiopia, Fiji, Finland, France, French Guiana, Gabon, Gambia, Georgia, Germany, Ghana, Gibraltar, Greece, Grenada, Guadeloupe, Guatemala, Guinea,

Spare part number	Description
	Guinea-Bissau, Guyana, Haiti, Honduras, Hong Kong, Hungary, Iceland, India, Ireland, Israel, Italy, the Ivory Coast, Jamaica, Jordan, Kazakhstan, Kenya, Kiribati, Kyrgyzstan, Laos, Latvia, Lebanon, Lesotho, Liberia, Liechtenstein, Lithuania, Luxembourg, Macedonia, Madagascar, Malawi, Malaysia, the Maldives, Mali, Malta, the Marshall Islands, Martinique, Mauritania, Mauritius, Mexico, Micronesia, Monaco, Mongolia, Montenegro, Morocco, Mozambique, Namibia, Nauru, Nepal, the Nether Antilles, the Netherlands, New Zealand, Nicaragua, Niger, Nigeria, Norway, Oman, Pakistan, Palau, Panama, Papua New Guinea, Paraguay, Peru, the Philippines, Poland, Portugal, the Republic of Moldova, Romania, Russia, Rwanda, Samoa, San Marino, Sao Tome and Principe, Saudi Arabia, Senegal, Serbia, the Seychelles, Sierra Leone, Singapore, Slovakia, Slovenia, the Solomon Islands, Somalia, South Africa, South Korea, Spain, Sri Lanka, St. Kitts and Nevis, St. Lucia, St. Vincent and the Grenadines, Suriname, Swaziland, Sweden, Switzerland, Taiwan, Tajikistan, Tanzania, Togo, Tonga, Trinidad and Tobago, Tunisia, Turkey, Turkmenistan, Tuvalu, Uganda, Ukraine, the United Arab Emirates, the United Kingdom, Uruguay, Uzbekistan, Vanuatu, Venezuela, Vietnam, Yemen, Zaire, Zambia, and Zimbabwe
487429-001	Plastics Kit (see Plastics Kit on page 25 for more Plastics Kit spare part information)
487431-001	Display inverter
487432-001	Cable Kit (see Cable Kit on page 26 for more Cable Kit spare part information)
487433-001	14.1-inch, WXGA AntiGlare LED display assembly for use on computer models equipped with a webcam (includes three WLAN antenna cables, two WWAN antenna cables, and two microphones)
487434-001	14.1-inch, WXGA AntiGlare display assembly for use on computer models equipped with a webcam (includes three WLAN antenna cables, two WWAN antenna cables, and two microphones)
487435-001	14.1-inch, WXGA+ AntiGlare display assembly for use on computer models equipped with a webcam (includes three WLAN antenna cables, two WWAN antenna cables, and two microphones)
487436-001	Fan
488189-001	Display bezel for use only with computer models equipped with a webcam
488190-001	Display bezel for use only with computer models not equipped with a webcam
490371-001	Power cord for use in the United States
490371-011	Power cord for use in Australia
490371-031	Power cord for use in the United Kingdom
490371-061	Power cord for use in Italy
490371-111	Power cord for use in Switzerland
490371-201	Power cord for use in Brazil
490371-291	Power cord for use in Japan
490371-AA1	Power cord for use in the People's Republic of China
490371-AB1	Power cord for use in Taiwan
490371-AD1	Power cord for use in South Korea
490371-AR1	Power cord for use in South Africa
490371-BB1	Power cord for use in Iceland
490371-D01	Power cord for use in Argentina
490371-D61	Power cord for use in India

Spare part number	Description
500325-001	Logo Kit
502322-0001	Upgrade bay device cradle

4 Removal and replacement procedures

Preliminary replacement requirements

Tools required

You will need the following tools to complete the removal and replacement procedures:

- Flat-bladed screwdriver
- Magnetic screwdriver
- Phillips P0 and P1 screwdrivers
- Torx T8 screwdriver

Service considerations

The following sections include some of the considerations that you must keep in mind during disassembly and assembly procedures.

 **NOTE:** As you remove each subassembly from the computer, place the subassembly (and all accompanying screws) away from the work area to prevent damage.

Plastic parts

Using excessive force during disassembly and reassembly can damage plastic parts. Use care when handling the plastic parts. Apply pressure only at the points designated in the maintenance instructions.

Cables and connectors

-
- △ **CAUTION:** When servicing the computer, be sure that cables are placed in their proper locations during the reassembly process. Improper cable placement can damage the computer.
-

Cables must be handled with extreme care to avoid damage. Apply only the tension required to unseat or seat the cables during removal and insertion. Handle cables by the connector whenever possible. In all cases, avoid bending, twisting, or tearing cables. Be sure that cables are routed in such a way that they cannot be caught or snagged by parts being removed or replaced. Handle flex cables with extreme care; these cables tear easily.

Drive handling

-
- △ **CAUTION:** Drives are fragile components that must be handled with care. To prevent damage to the computer, damage to a drive, or loss of information, observe these precautions:
-

Before removing or inserting a hard drive, shut down the computer. If you are unsure whether the computer is off or in Hibernation, turn the computer on, and then shut it down through the operating system.

Before handling a drive, be sure that you are discharged of static electricity. While handling a drive, avoid touching the connector.

Before removing a diskette drive or optical drive, be sure that a diskette or disc is not in the drive and be sure that the optical drive tray is closed.

Handle drives on surfaces covered with at least one inch of shock-proof foam.

Avoid dropping drives from any height onto any surface.

After removing a hard drive, an optical drive, or a diskette drive, place it in a static-proof bag.

Avoid exposing a hard drive to products that have magnetic fields, such as monitors or speakers.

Avoid exposing a drive to temperature extremes or liquids.

If a drive must be mailed, place the drive in a bubble pack mailer or other suitable form of protective packaging and label the package "FRAGILE."

Grounding guidelines

Electrostatic discharge damage

Electronic components are sensitive to electrostatic discharge (ESD). Circuitry design and structure determine the degree of sensitivity. Networks built into many integrated circuits provide some protection, but in many cases, ESD contains enough power to alter device parameters or melt silicon junctions.

A discharge of static electricity from a finger or other conductor can destroy static-sensitive devices or microcircuitry. Even if the spark is neither felt nor heard, damage may have occurred.

An electronic device exposed to ESD may not be affected at all and can work perfectly throughout a normal cycle. Or the device may function normally for a while, then degrade in the internal layers, reducing its life expectancy.

△ **CAUTION:** To prevent damage to the computer when you are removing or installing internal components, observe these precautions:

Keep components in their electrostatic-safe containers until you are ready to install them.

Use nonmagnetic tools.

Before touching an electronic component, discharge static electricity by using the guidelines described in this section.

Avoid touching pins, leads, and circuitry. Handle electronic components as little as possible.

If you remove a component, place it in an electrostatic-safe container.

The following table shows how humidity affects the electrostatic voltage levels generated by different activities.

△ **CAUTION:** A product can be degraded by as little as 700 V.

Typical electrostatic voltage levels			
Event	Relative humidity		
	10%	40%	55%
Walking across carpet	35,000 V	15,000 V	7,500 V
Walking across vinyl floor	12,000 V	5,000 V	3,000 V
Motions of bench worker	6,000 V	800 V	400 V
Removing DIPS from plastic tube	2,000 V	700 V	400 V
Removing DIPS from vinyl tray	11,500 V	4,000 V	2,000 V
Removing DIPS from Styrofoam	14,500 V	5,000 V	3,500 V
Removing bubble pack from PCB	26,500 V	20,000 V	7,000 V
Packing PCBs in foam-lined box	21,000 V	11,000 V	5,000 V

Packaging and transporting guidelines

Follow these grounding guidelines when packaging and transporting equipment:

- To avoid hand contact, transport products in static-safe tubes, bags, or boxes.
- Protect ESD-sensitive parts and assemblies with conductive or approved containers or packaging.
- Keep ESD-sensitive parts in their containers until the parts arrive at static-free workstations.
- Place items on a grounded surface before removing items from their containers.
- Always be properly grounded when touching a component or assembly.
- Store reusable ESD-sensitive parts from assemblies in protective packaging or nonconductive foam.
- Use transporters and conveyors made of antistatic belts and roller bushings. Be sure that mechanized equipment used for moving materials is wired to ground and that proper materials are selected to avoid static charging. When grounding is not possible, use an ionizer to dissipate electric charges.

Workstation guidelines

Follow these grounding workstation guidelines:

- Cover the workstation with approved static-shielding material.
- Use a wrist strap connected to a properly grounded work surface and use properly grounded tools and equipment.
- Use conductive field service tools, such as cutters, screwdrivers, and vacuums.
- When fixtures must directly contact dissipative surfaces, use fixtures made only of static-safe materials.
- Keep the work area free of nonconductive materials, such as ordinary plastic assembly aids and Styrofoam.
- Handle ESD-sensitive components, parts, and assemblies by the case or PCM laminate. Handle these items only at static-free workstations.
- Avoid contact with pins, leads, or circuitry.
- Turn off power and input signals before inserting or removing connectors or test equipment.

Equipment guidelines

Grounding equipment must include either a wrist strap or a foot strap at a grounded workstation.

- When seated, wear a wrist strap connected to a grounded system. Wrist straps are flexible straps with a minimum of one megohm $\pm 10\%$ resistance in the ground cords. To provide proper ground, wear a strap snugly against the skin at all times. On grounded mats with banana-plug connectors, use alligator clips to connect a wrist strap.
- When standing, use foot straps and a grounded floor mat. Foot straps (heel, toe, or boot straps) can be used at standing workstations and are compatible with most types of shoes or boots. On conductive floors or dissipative floor mats, use foot straps on both feet with a minimum of one megohm resistance between the operator and ground. To be effective, the conductive strips must be worn in contact with the skin.

The following grounding equipment is recommended to prevent electrostatic damage:

- Antistatic tape
- Antistatic smocks, aprons, and sleeve protectors
- Conductive bins and other assembly or soldering aids
- Nonconductive foam
- Conductive tabletop workstations with ground cords of one megohm resistance
- Static-dissipative tables or floor mats with hard ties to the ground
- Field service kits
- Static awareness labels
- Material-handling packages
- Nonconductive plastic bags, tubes, or boxes
- Metal tote boxes
- Electrostatic voltage levels and protective materials

The following table lists the shielding protection provided by antistatic bags and floor mats.

Material	Use	Voltage protection level
Antistatic plastic	Bags	1,500 V
Carbon-loaded plastic	Floor mats	7,500 V
Metallized laminate	Floor mats	5,000 V

Unknown user password

If the computer you are servicing has an unknown user password, follow these steps to clear the password:

 **NOTE:** These steps also clear CMOS.

1. Shut down the computer. If you are unsure whether the computer is off or in Hibernation, turn the computer on, and then shut it down through the operating system.
2. Disconnect all external devices connected to the computer.
3. Disconnect the power from the computer by first unplugging the power cord from the AC outlet and then unplugging the AC adapter from the computer.
4. Remove the battery (see [Battery on page 43](#)).
5. Remove the real-time clock (RTC) battery (see [RTC battery on page 65](#)).
6. Wait approximately 5 minutes.
7. Replace the RTC battery and reassemble the computer.
8. Connect AC power to the computer. Do not reinsert any batteries at this time.
9. Turn on the computer.

All passwords and all CMOS settings have been cleared.

Component replacement procedures

This chapter provides removal and replacement procedures.

There are as many as 72 screws, in 12 different sizes, that must be removed, replaced, or loosened when servicing the computer. Make special note of each screw size and location during removal and replacement.

Service tag

The service tag, affixed to the bottom of the computer, provides information that may be needed when troubleshooting system problems. The service tag provides the following information:

- (1) Product name: This is the product name affixed to the front of the computer.
- (2) Serial number (s/n): This is an alphanumeric identifier that is unique to each product.
- (3) Part number/Product number (p/n): This number provides specific information about the product's hardware components. The part number helps a service technician to determine what components and parts are needed.
- (4) Model description: This is the number used to locate documents, drivers, and support for the computer.
- (5) Warranty period: Describes the duration of the warranty period for the computer.

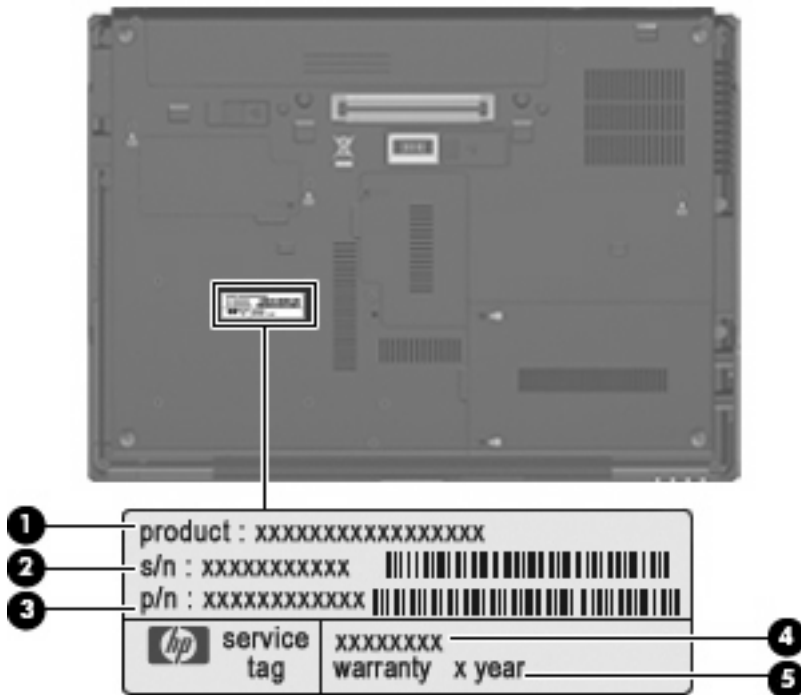

Computer feet

The computer feet are adhesive-backed rubber pads. The feet are included in the Rubber Kit, spare part number 482968-001. There are 4 rubber feet that attach to the base enclosure in the locations illustrated below.

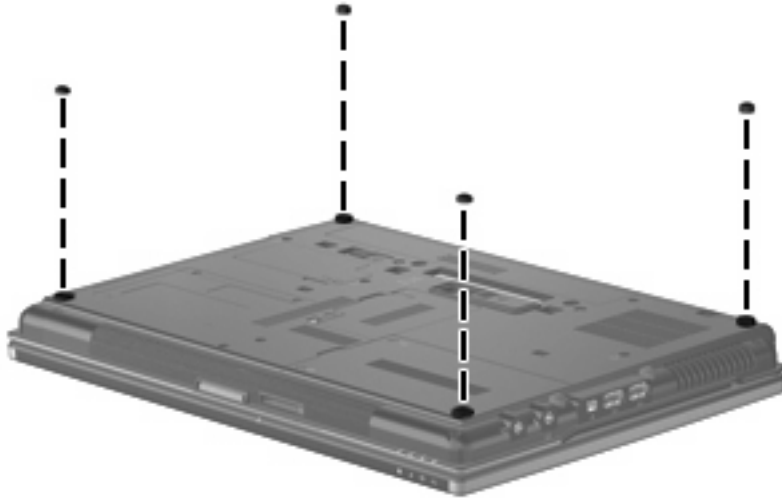

Battery

Description	Spare part number
6-cell, 55-Wh Li-ion battery	482962-001
4-cell, 37-Wh Li-ion battery	482961-001

Before disassembling the computer, follow these steps:

1. Shut down the computer. If you are unsure whether the computer is off or in Hibernation, turn the computer on, and then shut it down through the operating system.
2. Disconnect all external devices connected to the computer.
3. Disconnect the power from the computer by first unplugging the power cord from the AC outlet and then unplugging the AC adapter from the computer.

Remove the battery:

1. Turn the computer upside down on a flat surface, with the battery bay toward you.
2. Slide the battery release latch **(1)** to release the battery.
3. Remove the battery **(2)** from the computer.

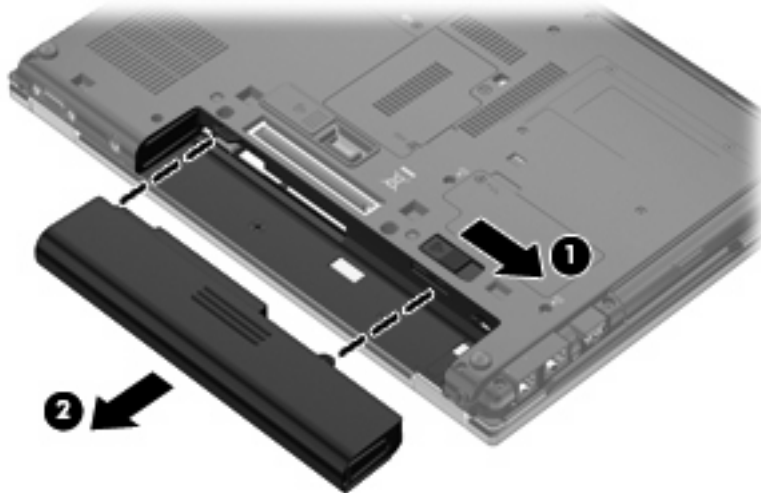

Install the battery by inserting it into the battery bay until you hear a click.

SIM

 **NOTE:** This section applies only to computer models with WWAN capability. If there is a SIM inserted in the SIM slot, it should be removed before disassembling the computer. Be sure the SIM is reinserted in the SIM slot after reassembling the computer.

Before removing the SIM, follow these steps:

1. Shut down the computer. If you are unsure whether the computer is off or in Hibernation, turn the computer on, and then shut it down through the operating system.
2. Disconnect all external devices connected to the computer.
3. Disconnect the power from the computer by first unplugging the power cord from the AC outlet and then unplugging the AC Adapter from the computer.
4. Remove the battery (see [Battery on page 43](#)).

Remove the SIM:

1. Press in on the SIM **(1)**. (The module is partially ejected from the SIM slot.)
2. Remove the SIM **(2)** from the SIM slot.

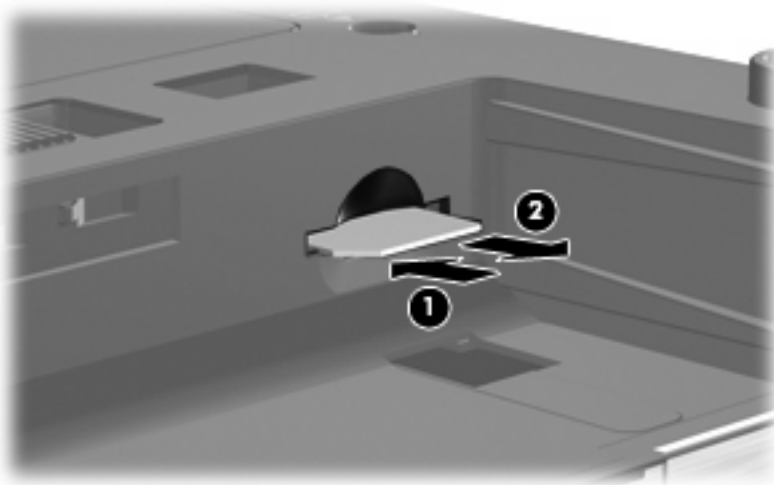

Reverse this procedure to install the SIM.

Display inverter

Description	Spare part number
Display inverter	487431-001

Before removing the display inverter, follow these steps:

1. Shut down the computer. If you are unsure whether the computer is off or in Hibernation, turn the computer on, and then shut it down through the operating system.
2. Disconnect all external devices connected to the computer.
3. Disconnect the power from the computer by first unplugging the power cord from the AC outlet and then unplugging the AC Adapter from the computer.
4. Remove the battery (see [Battery on page 43](#)).

Remove the display inverter:

1. Turn the computer right-side up, with the front toward you.
2. Open the computer as far as it will open.
3. Remove the two rubber screw covers (1) on the bottom edge of the display bezel. The rubber screw covers are available in the Display Rubber Kit, spare part number 482966-001.
4. Remove the two Phillips PM2.5×6.0 screws (2) that secure the bottom edge of the display bezel to the display enclosure.

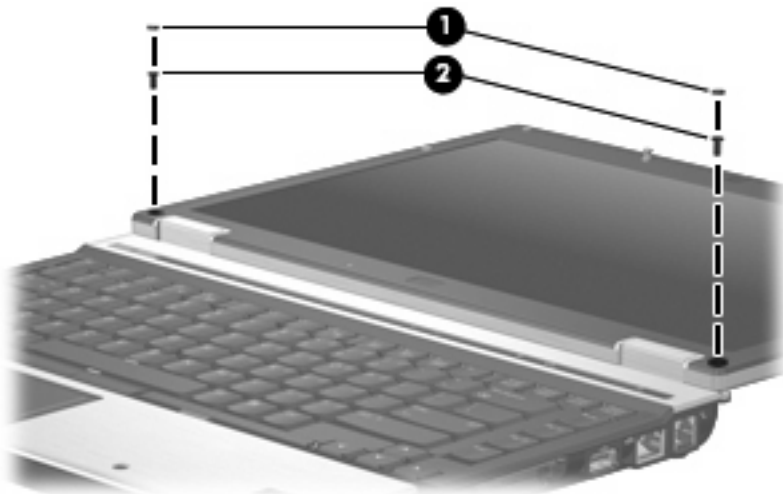

5. Flex the hinge cover areas (1) and the bottom edge (2) of the display bezel until the bezel disengages from the display enclosure.

6. Release the bottom edge of the display bezel (3) from the display assembly.

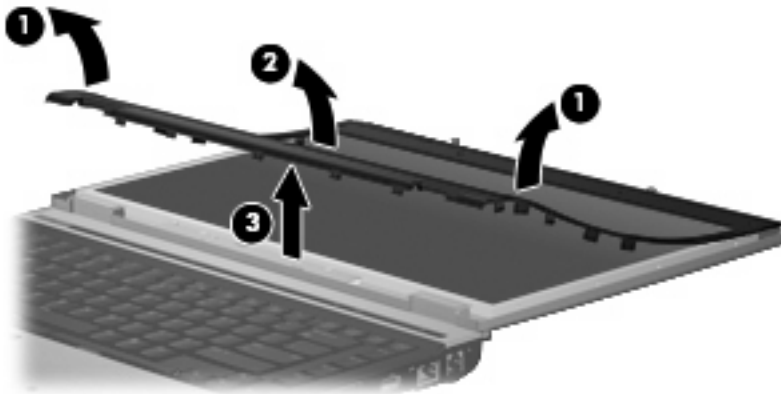

7. Release the zero insertion force (ZIF) connector (1) to which the keyboard light cable is attached, and disconnect the keyboard light cable from the display inverter.
8. Remove the two Phillips PM2.5×4.0 screws (2) that secure the display inverter to the display enclosure.
9. Release the display inverter (3) from the display enclosure as far as the display panel cable and backlight cable allow.
10. Disconnect the display panel cable (4) and the backlight cable (5) from the display inverter.

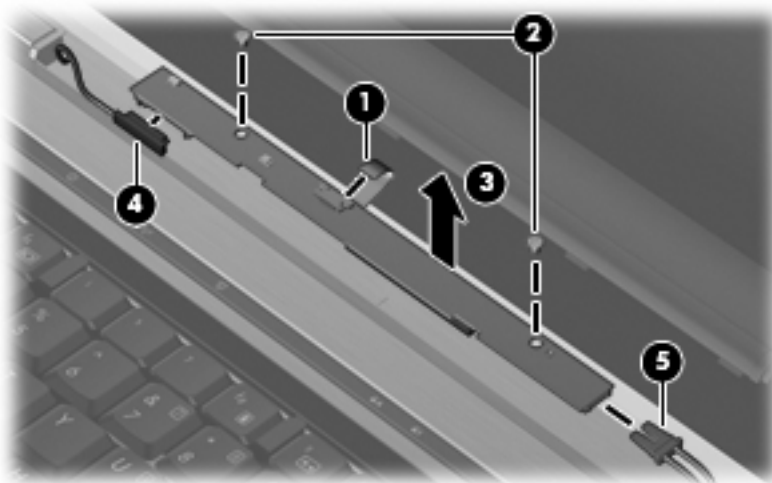

11. Remove the display inverter.

Reverse this procedure to install the display inverter.

Bluetooth module

 **NOTE:** The Bluetooth® module spare part kit does not include a Bluetooth module cable. The Bluetooth module cable is included in the Cable Kit, spare part number 487432-001. See [Bluetooth module cable on page 87](#) for removal procedures for the Bluetooth module cable.

Description	Spare part number
Bluetooth module	483113-001

Before removing the Bluetooth module, follow these steps:

1. Shut down the computer. If you are unsure whether the computer is off or in Hibernation, turn the computer on, and then shut it down through the operating system.
2. Disconnect all external devices connected to the computer.
3. Disconnect the power from the computer by first unplugging the power cord from the AC outlet and then unplugging the AC adapter from the computer.
4. Remove the battery (see [Battery on page 43](#)).

Remove the Bluetooth module:

1. Loosen the Phillips PM2.0×5.0 captive screw (1) that secures the Bluetooth module compartment cover to the computer.
2. Remove the Bluetooth module compartment cover (2) by lifting it straight up.

 **NOTE:** The Bluetooth module compartment cover is included in the Plastics Kit, spare part number 487429-001.

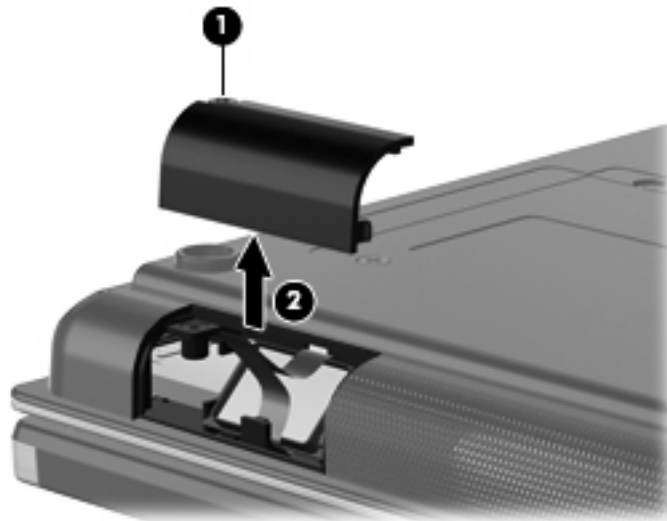

3. Release the Bluetooth module (1) from the computer as far as the Bluetooth module cable allows.

4. Disconnect the Bluetooth module cable (2) from the Bluetooth module.

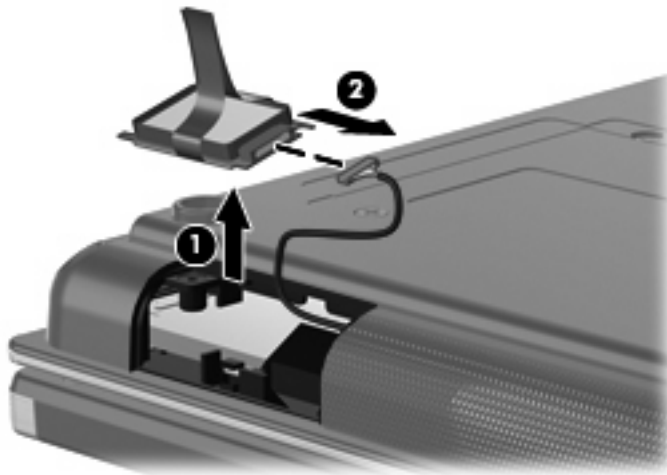

5. Remove the Bluetooth module.

Reverse this procedure to install the Bluetooth module.

Hard drive

 **NOTE:** All hard drive spare part kits include a hard drive bracket.

Description	Spare part number
250-GB, 5400-rpm	483187-001
160-GB, 7200-rpm	483186-001
160-GB, 5400-rpm	483185-001
120-GB, 7200-rpm	483184-001
120-GB, 5400-rpm	483183-001

Before removing the hard drive, follow these steps:

1. Shut down the computer. If you are unsure whether the computer is off or in Hibernation, turn the computer on, and then shut it down through the operating system.
2. Disconnect all external devices connected to the computer.
3. Disconnect the power from the computer by first unplugging the power cord from the AC outlet and then unplugging the AC adapter from the computer.
4. Remove the battery (see [Battery on page 43](#)).

Remove the hard drive:

1. Position the computer with the front toward you.
2. Loosen the two Phillips PM2.0×5.0 captive screws **(1)** that secure the hard drive bay cover to the computer.
3. Lift the left side of the hard drive bay cover **(2)**, swing it up and to the right, and remove the cover. The hard drive bay cover is included in the Plastics Kit, spare part number 487429-001.

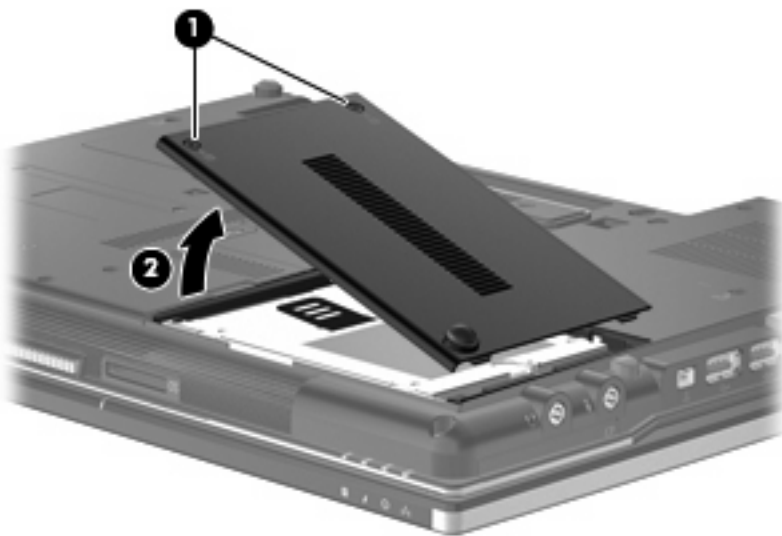

4. Loosen the Phillips PM2.5×10.0 captive screw **(1)** that secures the hard drive to the computer.

5. Grasp the Mylar tab (2) on the hard drive and slide the hard drive (3) to the right to disconnect it from the system board.
6. Remove the hard drive (4) from the hard drive bay.

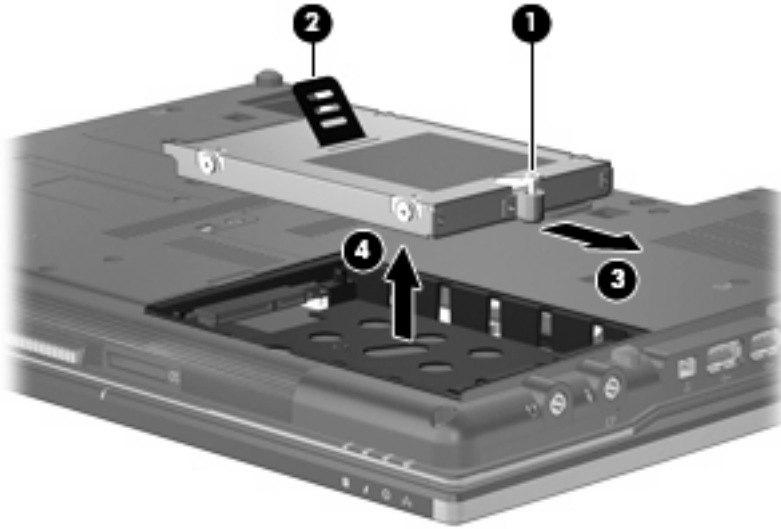

7. If it is necessary to replace the hard drive bracket, remove the two Phillips PM3.0×4.0 hard drive bracket screws (1) from each side of the hard drive.
8. Lift the bracket (2) straight up to remove it from the hard drive.

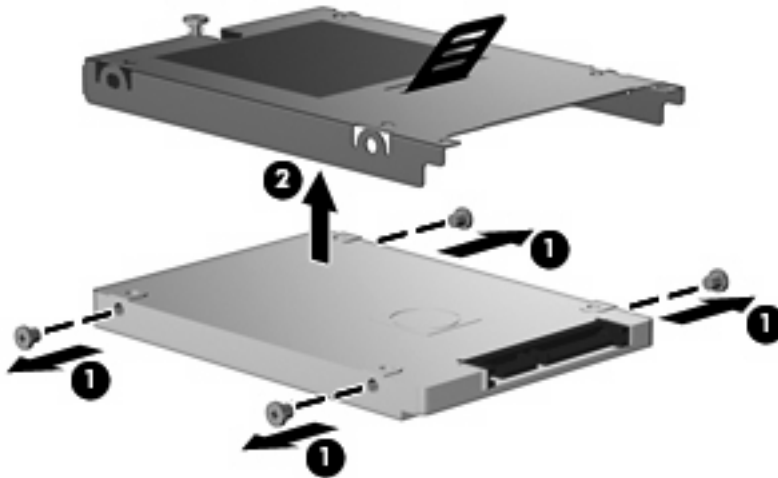

Reverse this procedure to reassemble and install the hard drive.

Optical drive

 **NOTE:** All optical drive spare part kits include an optical drive bezel.

Description	Spare part number
DVD±RW and CD-RW SuperMulti Double-Layer Combo Drive with LightScribe	483190-001
DVD/CD-RW Combo Drive	483189-001
DVD-ROM Drive	483191-001

Before removing the optical drive, follow these steps:

1. Shut down the computer. If you are unsure whether the computer is off or in Hibernation, turn the computer on, and then shut it down through the operating system.
2. Disconnect all external devices connected to the computer.
3. Disconnect the power from the computer by first unplugging the power cord from the AC outlet and then unplugging the AC adapter from the computer.
4. Remove the battery (see [Battery on page 43](#)).

Remove the optical drive:

1. Position the computer with the front toward you.
2. Loosen the Phillips PM2.5×9.0 captive screw (1) that secures the optical drive to the computer.
3. Insert a flat-bladed screwdriver or similar tool into the optical drive tab access (2) and press the tab to the left to release the optical drive from the computer.
4. Remove the optical drive (3) from the upgrade bay.

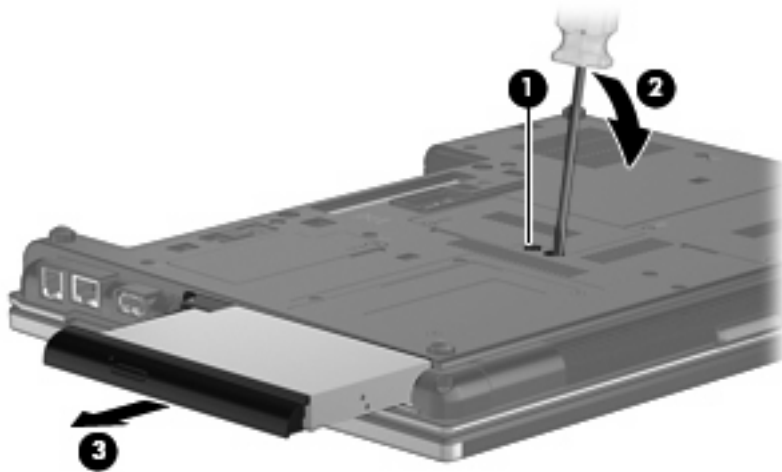

5. If it is necessary to replace the optical drive bracket, position the optical drive with the rear toward you.
6. Remove the two Phillips PM2.0×3.0 screws (1) that secure the optical drive bracket to the optical drive.

7. Remove the optical drive bracket (2).

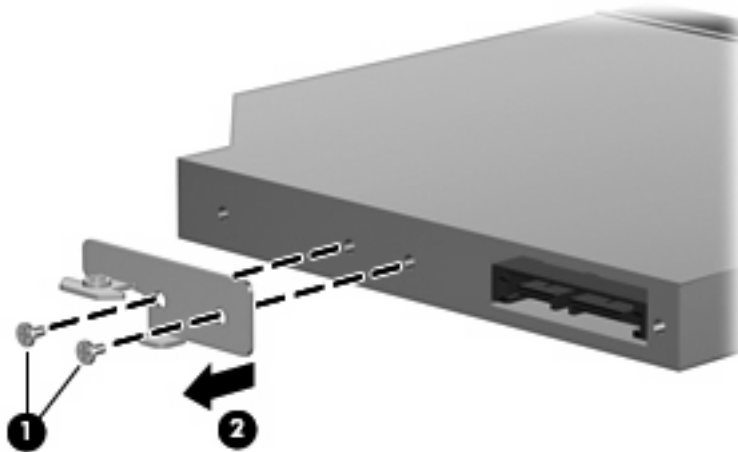

Reverse this procedure to reassemble and install an optical drive.

Upgrade bay device

Description	Spare part number
Upgrade bay device cradle	502322-001

Before removing the upgrade bay device, follow these steps:

1. Shut down the computer. If you are unsure whether the computer is off or in Hibernation, turn the computer on, and then shut it down through the operating system.
2. Disconnect all external devices connected to the computer.
3. Disconnect the power from the computer by first unplugging the power cord from the AC outlet and then unplugging the AC Adapter from the computer.
4. Remove the battery (see [Battery on page 43](#)).

Remove the upgrade bay device:

1. Position the computer with the front toward you.
2. Loosen the Phillips PM2.5×9.0 captive screw (1) that secures the upgrade bay device to the computer.
3. Remove the four Phillips PM2.5×4.0 screws (2) that secure the upgrade bay device to the computer.
4. Insert a flat-bladed screwdriver or similar tool into the upgrade bay device tab access (3) and press the tab to the left to release the upgrade bay device from the computer.

5. Remove the upgrade bay device (4) from the computer.

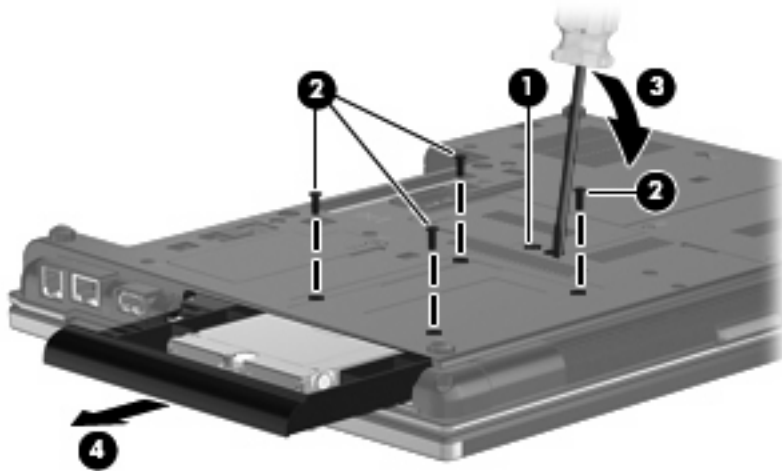

6. If it is necessary to remove the hard drive from the upgrade bay cradle, position the upgrade bay cradle with the front bezel toward you.
7. Loosen the Phillips PM2.5×10.0 captive screw (1) that secures the hard drive to the upgrade bay cradle.
8. Grasp the Mylar tab (2) on the hard drive and slide the hard drive (3) forward to disconnect it from the upgrade bay cradle.
9. Remove the hard drive (4) from the upgrade bay cradle.

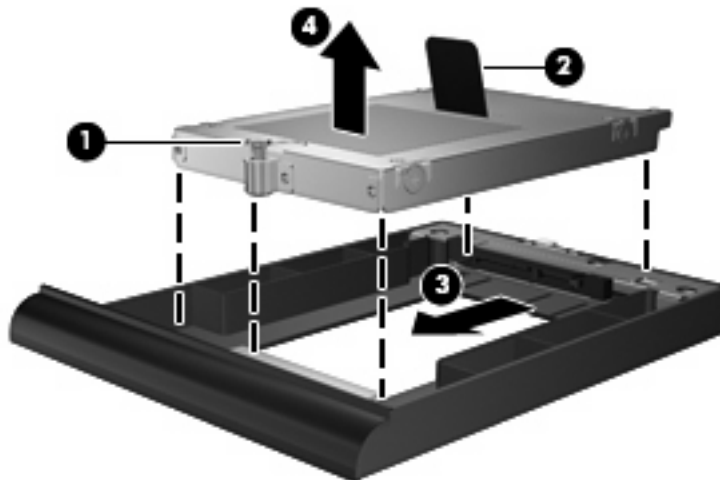

Reverse this procedure to install the upgrade bay device.

Expansion memory module

Description	Spare part number
4096-MB memory module (PC2-6400, 667-MHz, DDR2)	483195-001
2048-MB memory module (PC2-6400, 667-MHz, DDR2)	483194-001
1024-MB memory module (PC2-6400, 667-MHz, DDR2)	483193-001

Before removing the expansion memory module, follow these steps:

1. Shut down the computer. If you are unsure whether the computer is off or in Hibernation, turn the computer on, and then shut it down through the operating system.
2. Disconnect all external devices connected to the computer.
3. Disconnect the power from the computer by first unplugging the power cord from the AC outlet and then unplugging the AC adapter from the computer.
4. Remove the battery (see [Battery on page 43](#)).

Remove the memory module:

1. Position the computer with the front toward you.
2. Loosen the Phillips PM2.0×5.0 captive screw (1) that secures the memory module compartment cover to the computer.
3. Lift the left side of the cover (2), swing it up and to the right, and remove the cover. The memory module compartment cover is included in the Plastics Kit, spare part number 487429-001.

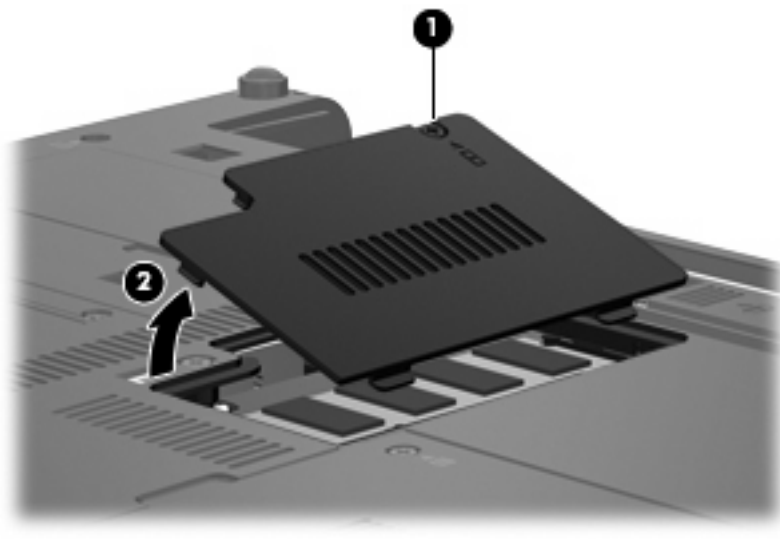

4. Spread the retaining tabs (1) on each side of the memory module slot to release the memory module. (The edge of the module opposite the slot rises away from the computer.)

5. Remove the memory module (2) by pulling the module away from the slot at an angle.

 **NOTE:** Memory modules are designed with a notch (3) to prevent incorrect insertion into the memory module slot.

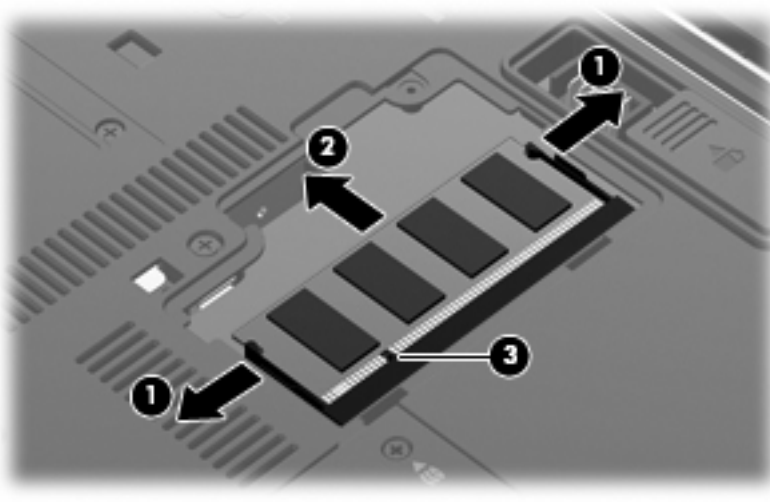

Reverse this procedure to install the expansion memory module.

WWAN module

Description	Spare part number
HP un2400 Mobile Broadband WWAN module	483377-001

Before removing the WWAN module, follow these steps:

1. Shut down the computer. If you are unsure whether the computer is off or in Hibernation, turn the computer on, and then shut it down through the operating system.
2. Disconnect all external devices connected to the computer.
3. Disconnect the power from the computer by first unplugging the power cord from the AC outlet and then unplugging the AC Adapter from the computer.
4. Remove the battery (see [Battery on page 43](#)).

Remove the WWAN module:

1. Loosen the Phillips PM2.0×5.0 captive screw (1) that secures the WWAN module compartment cover to the computer.

2. Lift the left side of the cover (2), swing it up and to the right, and remove the cover. The WWAN module compartment cover is included in the Plastics Kit, spare part 487429-001.

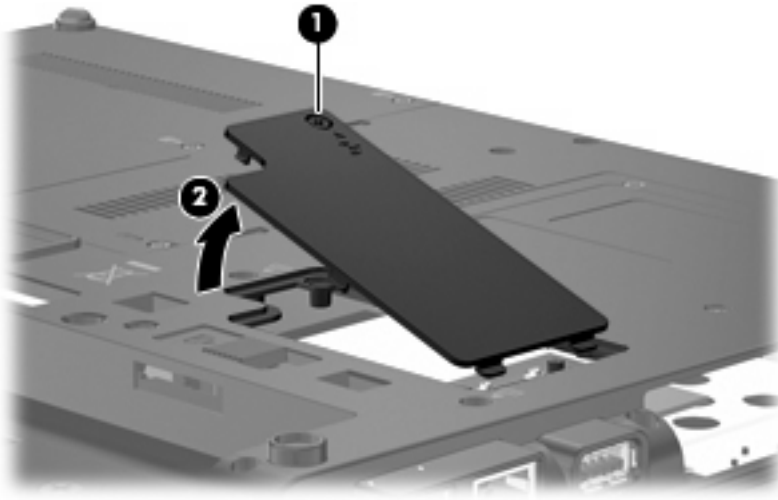

3. Disconnect the WWAN antenna cables (1) from the terminals on the WWAN module.

 **NOTE:** The red WWAN antenna cable is connected to the WWAN module “Main” terminal. The blue WWAN antenna cable is connected to the WWAN module “Aux” terminal.

4. Remove the two Phillips PM2.5×4.0 screws (2) that secure the WWAN module to the computer. (The edge of the module opposite the slot rises away from the computer.)
5. Remove the WWAN module (3) by pulling the module away from the slot at an angle.

 **NOTE:** WWAN modules are designed with a notch (4) to prevent incorrect insertion into the WWAN module slot.

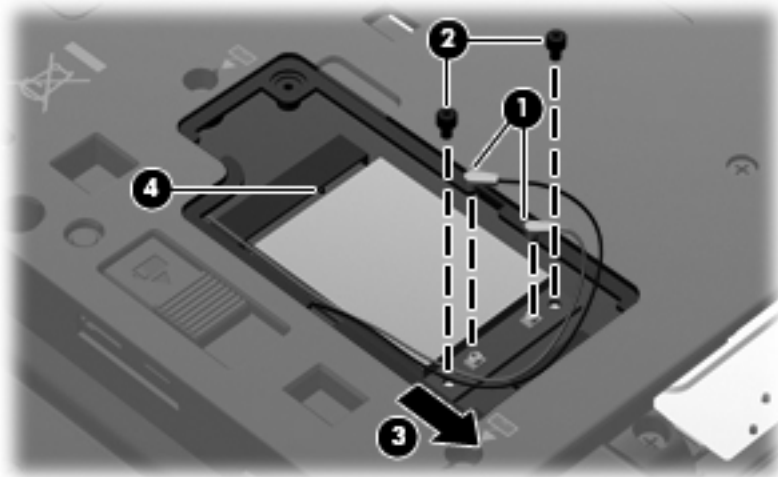

Reverse this procedure to install the WWAN module.

Keyboard

 **NOTE:** All keyboard spare part kits include a keyboard cable, keyboard shield, pointing stick, and pointing stick cable.

Country or region	Spare part number	Country or region	Spare part number
Belgium	483010-A41	Norway	483010-091
Brazil	483010-201	Portugal	483010-131
The Czech Republic	483010-221	Russia	483010-251
Denmark	483010-081	Saudi Arabia	483010-171
France	483010-051	Sweden and Finland	483010-B71
French Canada	483010-121	Slovakia	483010-231
Germany	483010-041	South Korea	483010-AD1
Greece	483010-DJ1	Spain	483010-071
Hungary	483010-211	Switzerland	483010-BG1
Iceland	483010-DD1	Taiwan	483010-AB1
Israel	483010-BB1	Thailand	483010-281
Italy	483010-061	Turkey	483010-141
Japan	483010-291	The United Kingdom	483010-031
Latin America	483010-161	The United States	483010-001
The Netherlands	483010-B31		
Pointing stick rubber caps			486565-001

Before removing the keyboard, follow these steps:

1. Shut down the computer. If you are unsure whether the computer is off or in Hibernation, turn the computer on, and then shut it down through the operating system.
2. Disconnect all external devices connected to the computer.
3. Disconnect the power from the computer by first unplugging the power cord from the AC outlet and then unplugging the AC Adapter from the computer.
4. Remove the battery (see [Battery on page 43](#)).

Remove the keyboard:

1. Position the computer with front toward you.

2. Loosen the three Phillips PM2.5×9.0 captive screws that secure the keyboard to the computer.

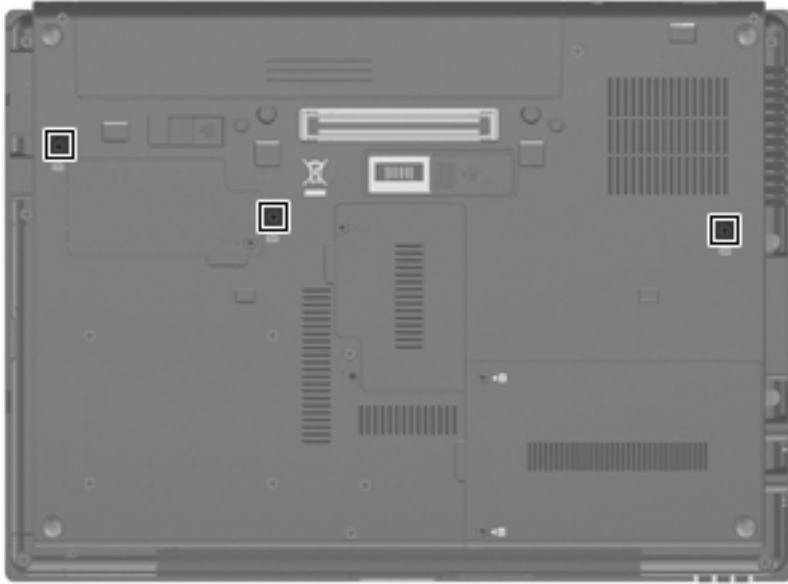

3. Turn the computer display-side up, with the front toward you.
4. Open the computer as far as possible.
5. Slide the four keyboard retention tabs (1) toward you. The tabs are located between the **esc** and **f1** keys, between the **f4** and **f5** keys, between the **f8** and **f9** keys, and between the **f12** and **scroll** keys.
6. Lift the rear edge of the keyboard (2), and swing it up and forward until it rests upside down on the palm rest.

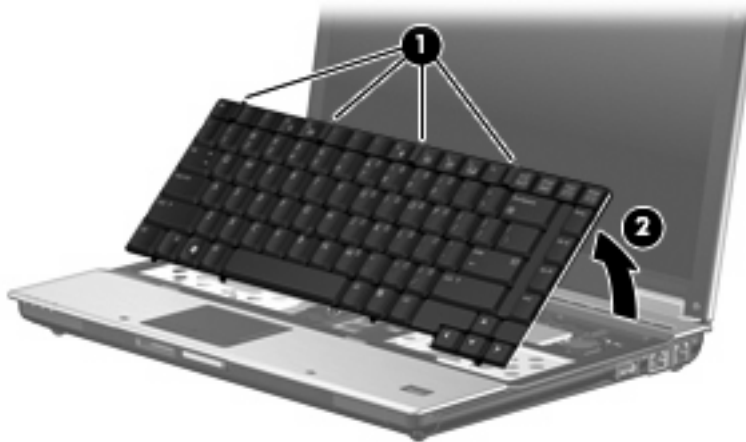

7. Release the ZIF connector (1) to which the pointing stick cable is attached, and disconnect the pointing stick cable (2) from the system board.

8. Release the ZIF connector (3) to which the keyboard cable is attached, and disconnect the keyboard cable (4) from the system board.

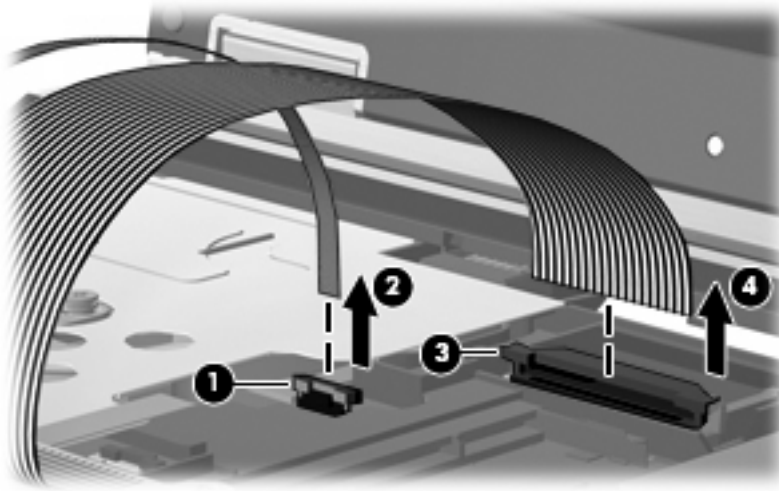

9. Remove the keyboard.

Reverse this procedure to install the keyboard.

Primary memory module

Description	Spare part number
4096-MB memory module (PC2-6400, 667-MHz, DDR2)	483195-001
2048-MB memory module (PC2-6400, 667-MHz, DDR2)	483194-001
1024-MB memory module (PC2-6400, 667-MHz, DDR2)	483193-001

Before removing the primary memory module, follow these steps:

1. Shut down the computer. If you are unsure whether the computer is off or in Hibernation, turn the computer on, and then shut it down through the operating system.
2. Disconnect all external devices connected to the computer.
3. Disconnect the power from the computer by first unplugging the power cord from the AC outlet and then unplugging the AC Adapter from the computer.
4. Remove the battery (see [Battery on page 43](#)).
5. Remove the keyboard (see [Keyboard on page 57](#)).

Remove the primary memory module:

1. Spread the retaining tabs (1) on each side of the memory module slot to release the memory module. (The edge of the module opposite the slot rises away from the computer.)

2. Remove the memory module (2) by pulling the module away from the slot at an angle.

 **NOTE:** Memory modules are designed with a notch (3) to prevent incorrect insertion into the memory module slot.

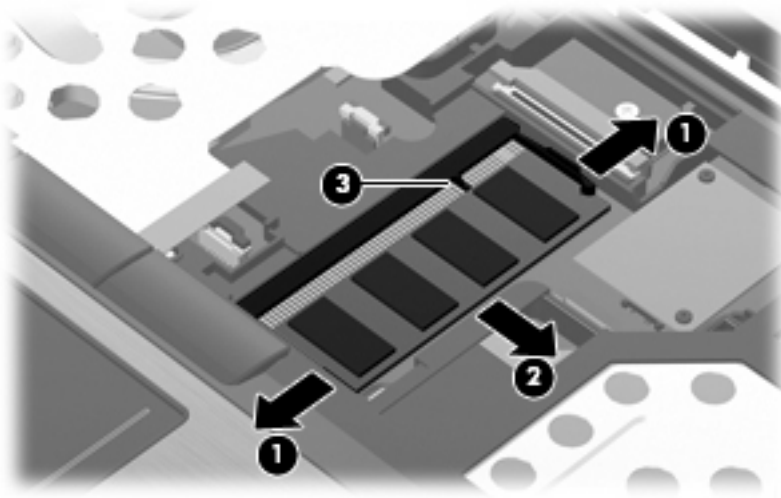

Reverse this procedure to install the primary memory module.

Modem module

 **NOTE:** The modem module spare part kits do not include a modem module cable. The modem module cable is included in the Cable Kit, spare part number 487432-001.

Description	Spare part number
For use in all countries and regions except Australia and New Zealand	461750-001
Modem module for use only in Australia and New Zealand	461750-011

Before removing the modem module, follow these steps:

1. Shut down the computer. If you are unsure whether the computer is off or in Hibernation, turn the computer on, and then shut it down through the operating system.
2. Disconnect all external devices connected to the computer.
3. Disconnect the power from the computer by first unplugging the power cord from the AC outlet and then unplugging the AC adapter from the computer.
4. Remove the battery (see [Battery on page 43](#)).
5. Remove the keyboard (see [Keyboard on page 57](#)).

Remove the modem module:

1. Remove the two Phillips PM2.5×4.0 screws (1) that secure the modem module to the system board.
2. Release the modem module (2) from the computer as far as the modem module cable allows.
3. Disconnect the modem module cable (3) from the modem module.

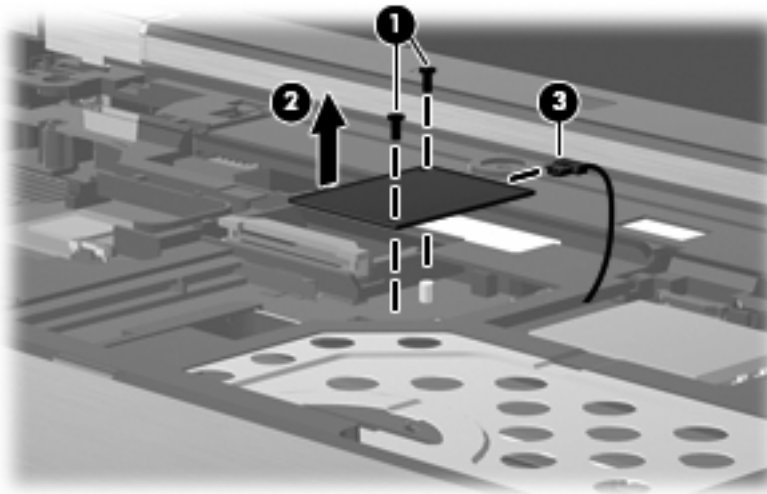

4. Remove the modem module.

Reverse this procedure to install the modem module.

WLAN module

Description	Spare part number
Intel Wi-Fi Link 5300 802.11a/b/g/n WLAN module for use in all countries and regions	480986-001
Intel Wi-Fi Link 5100 802.11a/b/g/n WLAN module for use in all countries and regions	480985-001
Intel Wi-Fi Link 5100 802.11a/b/g WLAN module for use in all countries and regions	482957-001
Broadcom 4322 802.11a/b/g/n WLAN modules:	
<ul style="list-style-type: none"> For use in Antigua and Barbuda, Barbados, Belize, Canada, the Cayman Islands, Guam, Puerto Rico, Trinidad and Tobago, the U.S. Virgin Islands, and the United States 	487330-001
<ul style="list-style-type: none"> For use in Afghanistan, Albania, Algeria, Andorra, Angola, Antigua and Barbuda, Argentina, Armenia, Aruba, Australia, Austria, Azerbaijan, the Bahamas, Bahrain, Bangladesh, Barbados, Belarus, Belgium, Belize, Benin, Bermuda, Bhutan, Bolivia, Bosnia and Herzegovina, Botswana, Brazil, the British Virgin Islands, Brunei, Bulgaria, Burkina Faso, Burundi, Cameroon, Cape Verde, the Central African Republic, Chad, Chile, the People's Republic of China, Colombia, Comoros, the Congo, Costa Rica, Croatia, Cyprus, the Czech Republic, Denmark, Djibouti, Dominica, the Dominican Republic, East Timor, Ecuador, Egypt, El Salvador, Equatorial Guinea, Eritrea, Estonia, Ethiopia, Fiji, Finland, France, French Guiana, Gabon, Gambia, Georgia, Germany, Ghana, Gibraltar, Greece, Grenada, Guadeloupe, Guatemala, Guinea, Guinea-Bissau, Guyana, Haiti, Honduras, Hong Kong, Hungary, Iceland, India, Ireland, Israel, Italy, the Ivory Coast, Jamaica, Jordan, Kazakhstan, Kenya, Kiribati, Kyrgyzstan, Laos, Latvia, Lebanon, Lesotho, Liberia, Liechtenstein, Lithuania, Luxembourg, Macedonia, Madagascar, Malawi, Malaysia, the Maldives, Mali, Malta, the Marshall Islands, Martinique, Mauritania, Mauritius, Mexico, Micronesia, Monaco, Mongolia, Montenegro, Morocco, Mozambique, Namibia, Nauru, Nepal, the Nether Antilles, the Netherlands, New Zealand, Nicaragua, Niger, Nigeria, Norway, Oman, Pakistan, Palau, Panama, Papua New Guinea, Paraguay, Peru, the Philippines, Poland, Portugal, the Republic of Moldova, Romania, Russia, Rwanda, Samoa, San Marino, Sao Tome and Principe, Saudi Arabia, Senegal, Serbia, the Seychelles, Sierra Leone, Singapore, Slovakia, Slovenia, the Solomon Islands, Somalia, South Africa, South Korea, Spain, Sri Lanka, St. Kitts and Nevis, St. Lucia, St. Vincent and the Grenadines, Suriname, Swaziland, Sweden, Switzerland, Taiwan, Tajikistan, Tanzania, Togo, Tonga, Trinidad and Tobago, Tunisia, Turkey, Turkmenistan, Tuvalu, Uganda, Ukraine, the United Arab Emirates, the United Kingdom, Uruguay, Uzbekistan, Vanuatu, Venezuela, Vietnam, Yemen, Zaire, Zambia, and Zimbabwe 	487330-002
Broadcom BCM4312 802.11b/g WLAN modules:	
<ul style="list-style-type: none"> For use in Antigua and Barbuda, Barbados, Belize, Canada, the Cayman Islands, Guam, Puerto Rico, Trinidad and Tobago, the U.S. Virgin Islands, and the United States 	459263-001
<ul style="list-style-type: none"> For use in Afghanistan, Albania, Algeria, Andorra, Angola, Antigua and Barbuda, Argentina, Armenia, Aruba, Australia, Austria, Azerbaijan, the Bahamas, Bahrain, Bangladesh, Barbados, Belarus, Belgium, Belize, Benin, Bermuda, Bhutan, Bolivia, Bosnia and Herzegovina, Botswana, Brazil, the British Virgin Islands, Brunei, Bulgaria, Burkina Faso, Burundi, Cameroon, Cape Verde, the Central African Republic, Chad, Chile, the People's Republic of China, Colombia, Comoros, the Congo, Costa Rica, Croatia, Cyprus, the Czech Republic, Denmark, Djibouti, Dominica, the Dominican Republic, East Timor, Ecuador, Egypt, El Salvador, Equatorial Guinea, Eritrea, Estonia, Ethiopia, Fiji, Finland, France, French Guiana, Gabon, Gambia, Georgia, Germany, Ghana, Gibraltar, Greece, Grenada, Guadeloupe, Guatemala, Guinea, Guinea-Bissau, Guyana, Haiti, Honduras, Hong Kong, Hungary, Iceland, India, Ireland, Israel, Italy, the Ivory Coast, Jamaica, Jordan, Kazakhstan, Kenya, Kiribati, Kyrgyzstan, Laos, Latvia, Lebanon, Lesotho, Liberia, Liechtenstein, Lithuania, Luxembourg, Macedonia, Madagascar, Malawi, Malaysia, the Maldives, Mali, Malta, the Marshall Islands, Martinique, Mauritania, Mauritius, Mexico, Micronesia, Monaco, Mongolia, Montenegro, Morocco, Mozambique, Namibia, Nauru, Nepal, the Nether Antilles, the Netherlands, New Zealand, Nicaragua, Niger, Nigeria, Norway, Oman, Pakistan, Palau, Panama, Papua New Guinea, Paraguay, Peru, the Philippines, Poland, Portugal, the Republic of Moldova, Romania, Russia, Rwanda, Samoa, San Marino, Sao Tome and Principe, Saudi Arabia, Senegal, Serbia, the Seychelles, 	459263-002

Description	Spare part number
Sierra Leone, Singapore, Slovakia, Slovenia, the Solomon Islands, Somalia, South Africa, South Korea, Spain, Sri Lanka, St. Kitts and Nevis, St. Lucia, St. Vincent and the Grenadines, Suriname, Swaziland, Sweden, Switzerland, Taiwan, Tajikistan, Tanzania, Togo, Tonga, Trinidad and Tobago, Tunisia, Turkey, Turkmenistan, Tuvalu, Uganda, Ukraine, the United Arab Emirates, the United Kingdom, Uruguay, Uzbekistan, Vanuatu, Venezuela, Vietnam, Yemen, Zaire, Zambia, and Zimbabwe	

Before removing the WLAN module, follow these steps:

1. Shut down the computer. If you are unsure whether the computer is off or in Hibernation, turn the computer on, and then shut it down through the operating system.
2. Disconnect all external devices connected to the computer.
3. Disconnect the power from the computer by first unplugging the power cord from the AC outlet and then unplugging the AC adapter from the computer.
4. Remove the battery (see [Battery on page 43](#)).
5. Remove the keyboard (see [Keyboard on page 57](#)).

Remove the WLAN module:

1. Disconnect the WLAN antenna cables (1) from the terminals on the WLAN module.

 **NOTE:** The black WLAN antenna cable is connected to the WLAN module “Main” terminal. The white WLAN antenna cable is connected to the WLAN module “Aux” terminal. If the computer is equipped with an 802.11a/b/g/n WLAN module, the yellow WLAN antenna cable (2) is connected to the middle terminal on the WLAN module.

2. Remove the two Phillips PM2.5×4.0 screws (3) that secure the WLAN module to the computer. (The edge of the module opposite the slot rises away from the computer.)
3. Remove the WLAN module (4) by pulling the module away from the slot at an angle.

 **NOTE:** WLAN modules are designed with a notch (5) to prevent incorrect insertion into the WLAN module slot.

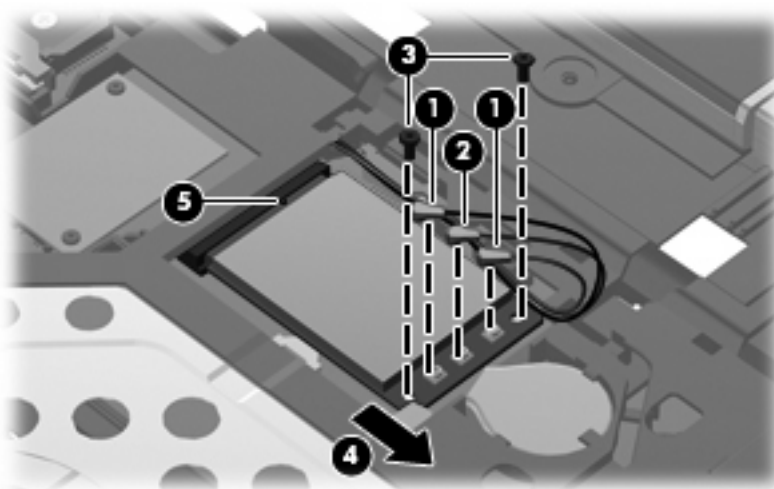

Reverse this procedure to install the WLAN module.

RTC battery

 **NOTE:** Removing the RTC battery and leaving it uninstalled for 5 or more minutes causes all passwords and CMOS settings to be cleared.

Description	Spare part number
RTC battery	482963-001

Before removing the RTC battery, follow these steps:

1. Shut down the computer. If you are unsure whether the computer is off or in Hibernation, turn the computer on, and then shut it down through the operating system.
2. Disconnect all external devices connected to the computer.
3. Disconnect the power from the computer by first unplugging the power cord from the AC outlet and then unplugging the AC adapter from the computer.
4. Remove the battery (see [Battery on page 43](#)).
5. Remove the keyboard (see [Keyboard on page 57](#)).

Remove the RTC battery:

1. Disconnect the RTC battery cable (1) from the system board.
2. Remove the RTC battery (2) from the clip built into the top cover.

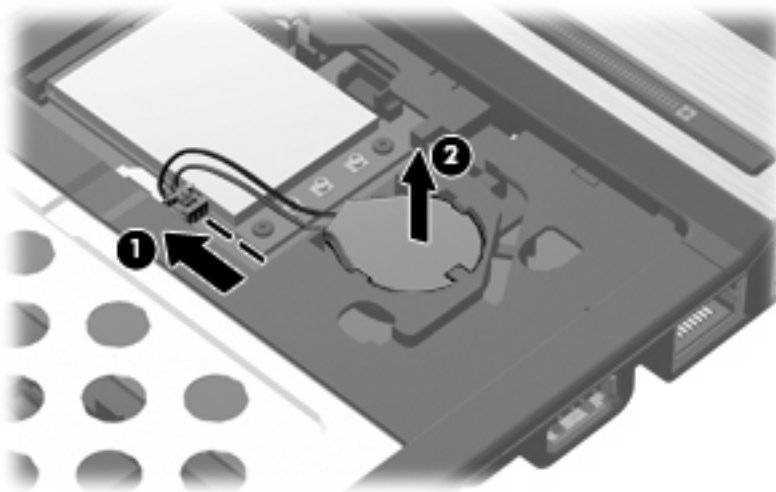

Reverse this procedure to install the RTC battery.

Switch cover

Description	Spare part number
Switch cover (includes capacitive board and cable)	486307-001

Before removing the switch cover, follow these steps:

1. Shut down the computer. If you are unsure whether the computer is off or in Hibernation, turn the computer on, and then shut it down through the operating system.
2. Disconnect all external devices connected to the computer.
3. Disconnect the power from the computer by first unplugging the power cord from the AC outlet and then unplugging the AC adapter from the computer.
4. Remove the battery (see [Battery on page 43](#)).
5. Remove the keyboard (see [Keyboard on page 57](#)).

Remove the switch cover:

1. Close the computer and turn it upside down, with the rear panel toward you.
2. Remove the following:
 - (1) Two rubber screw covers. Screw covers are available in the Rubber Kit, spare part number 482966-001.
 - (2) Three Torx T8M2.5×7.0 screws.
 - (3) Two Phillips PM2.0×4.0 broad-head screws.

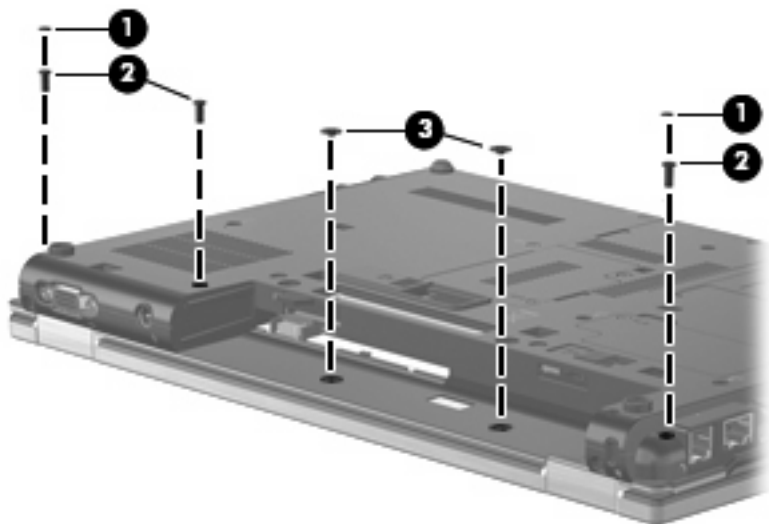

3. Turn the computer display-side up, with the front toward you.
4. Open the computer as far as possible.

5. Lift the right side of the keyboard shield (1) until it rests at an angle, and then remove the shield (2) by lifting it straight up.

 **NOTE:** The keyboard shield is included with the keyboard spare part kit.

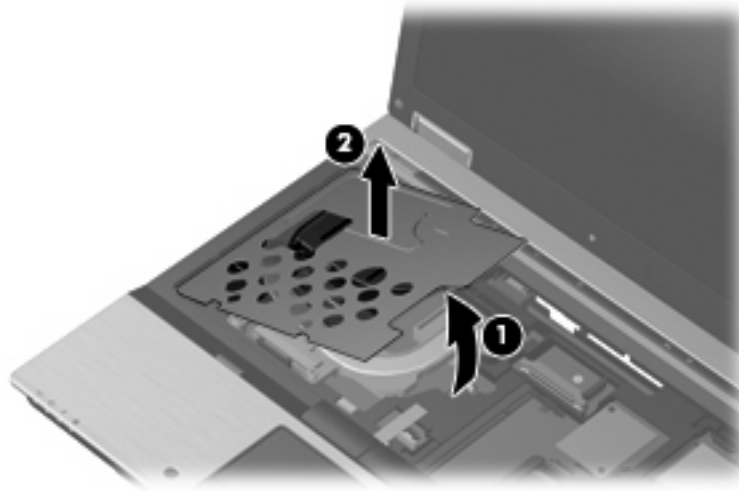

6. Release the ZIF connector (1) to which the power button board cable is attached, and disconnect the power button board cable from the system board.
7. Release the ZIF connector (2) to which the LED board cable is attached, and disconnect the LED board cable from the system board.
8. Remove the switch cover by lifting it straight up (3).

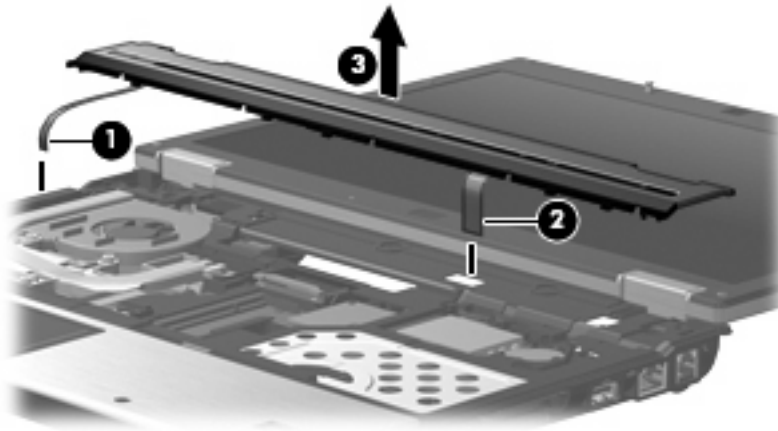

Reverse this procedure to install the switch cover.

Power button board

Description	Spare part number
Power button board (includes cable)	482964-001

Before removing the power button board, follow these steps:

1. Shut down the computer. If you are unsure whether the computer is off or in Hibernation, turn the computer on, and then shut it down through the operating system.
2. Disconnect all external devices connected to the computer.
3. Disconnect the power from the computer by first unplugging the power cord from the AC outlet and then unplugging the AC Adapter from the computer.
4. Remove the battery (see [Battery on page 43](#)).
5. Remove the keyboard (see [Keyboard on page 57](#)).
6. Remove the switch cover (see [Switch cover on page 66](#)).

Remove the power button board:

1. Turn the switch cover upside down, with the front toward you.
2. Remove the Phillips PM2.0×4.0 screw (1) that secures the power button board to the switch cover.
3. Lift the right side of the power button board (2) until it rests at an angle.
4. Remove the power button board (3) by sliding the board to the right at an angle.

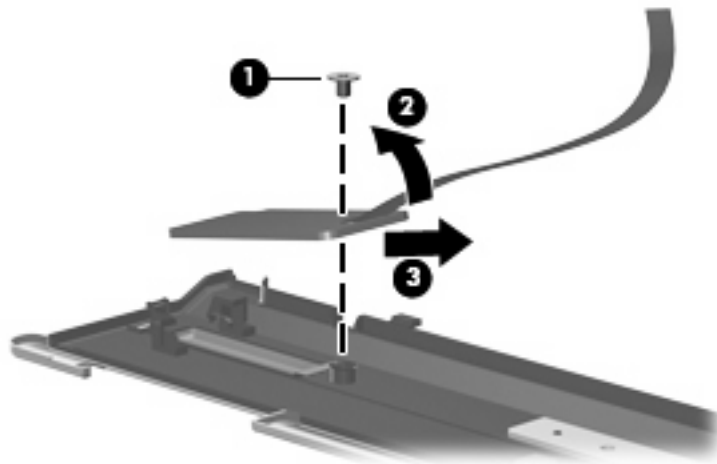

Reverse this procedure to install the power button board.

Fan

Description	Spare part number
Fan	487436-001

Before removing the fan, follow these steps:

1. Shut down the computer. If you are unsure whether the computer is off or in Hibernation, turn the computer on, and then shut it down through the operating system.
2. Disconnect all external devices connected to the computer.
3. Disconnect the power from the computer by first unplugging the power cord from the AC outlet and then unplugging the AC adapter from the computer.
4. Remove the battery (see [Battery on page 43](#)).
5. Remove the keyboard (see [Keyboard on page 57](#)).
6. Remove the switch cover (see [Switch cover on page 66](#)).

Remove the fan:

1. Disconnect the fan cable (1) from the system board.
2. Remove the Phillips PM2.5×7.0 screw (2) that secures the fan to the base enclosure.
3. Lift the front edge of the fan (3) until it rests at an angle.
4. Remove the fan (4) by sliding it forward at an angle.

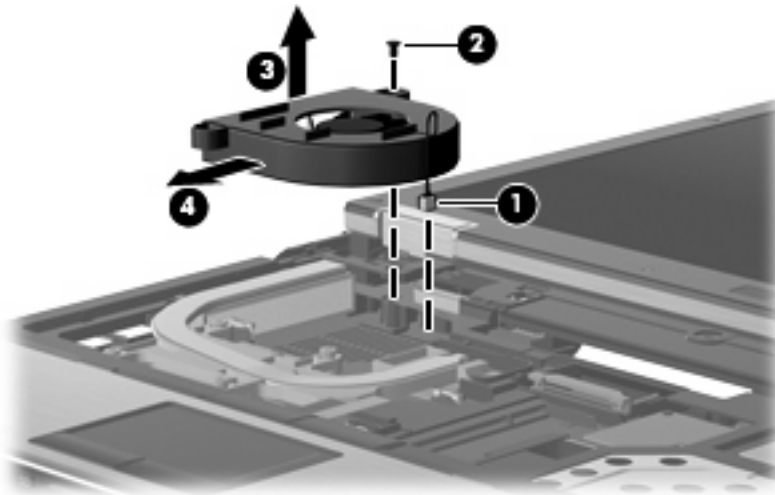

Reverse this procedure to install the fan.

 **NOTE:** To properly ventilate the computer, allow at least a 7.6-cm (3-inch) clearance on the left side of the computer.

The computer uses an electric fan for ventilation. The fan is controlled by a temperature sensor and is designed to turn on automatically when high temperature conditions exist. These conditions are affected by high external temperatures, system power consumption, power management/battery conservation

configurations, battery fast charging, and software requirements. Exhaust air is displaced through the ventilation grill located on the left side of the computer.

Heat sink

 **NOTE:** The heat sink spare part kits include replacement thermal material.

Description	Spare part number
For use only with computer models with discrete graphics subsystem memory	483011-001
For use only with computer models with UMA graphics subsystem memory	483012-001

Before removing the heat sink, follow these steps:

1. Shut down the computer. If you are unsure whether the computer is off or in Hibernation, turn the computer on, and then shut it down through the operating system.
2. Disconnect all external devices connected to the computer.
3. Disconnect the power from the computer by first unplugging the power cord from the AC outlet and then unplugging the AC adapter from the computer.
4. Remove the battery (see [Battery on page 43](#)).
5. Remove the following.
 - a. Keyboard (see [Keyboard on page 57](#))
 - b. Switch cover (see [Switch cover on page 66](#))
 - c. Fan (see [Fan on page 69](#))

Remove the heat sink:

 **NOTE:** Steps 1 through 5 apply only to computer models equipped with discrete graphics subsystem memory. See steps 6 through 8 for removing the heat sink on computer models with UMA graphics subsystem memory.

1. Following the 1, 2, 3, 4 sequence stamped into the heat sink, loosen the four Phillips PM2.5×11.0 captive screws (**1**) that secure the heat sink to the system board.

2. Remove the Phillips PM2.5×4.0 screw (2) that secures the heat sink to the system board.

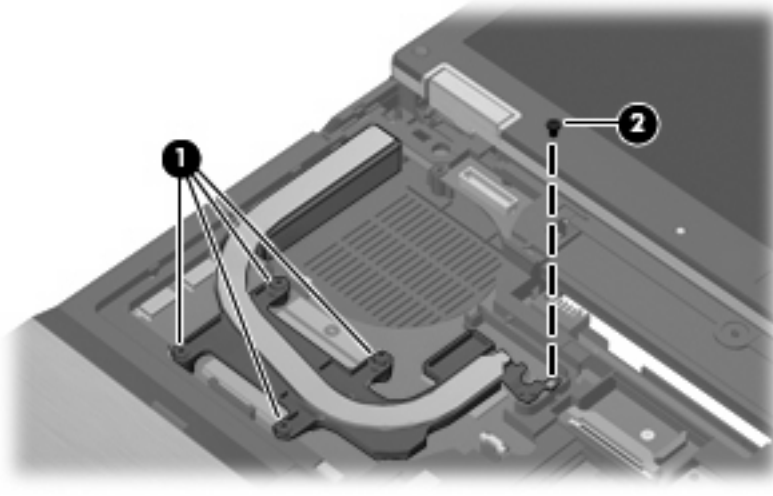

3. Lift the right side of the heat sink (1) until it rests at angle.

 **NOTE:** Due to the adhesive quality of the thermal material located between the heat sink and system board components, it may be necessary to move the heat sink from side to side to detach it.

4. Release the heat sink (2) by sliding it to the right until it clears the left side of the top cover.

5. Remove the heat sink (3) by sliding it up and forward.

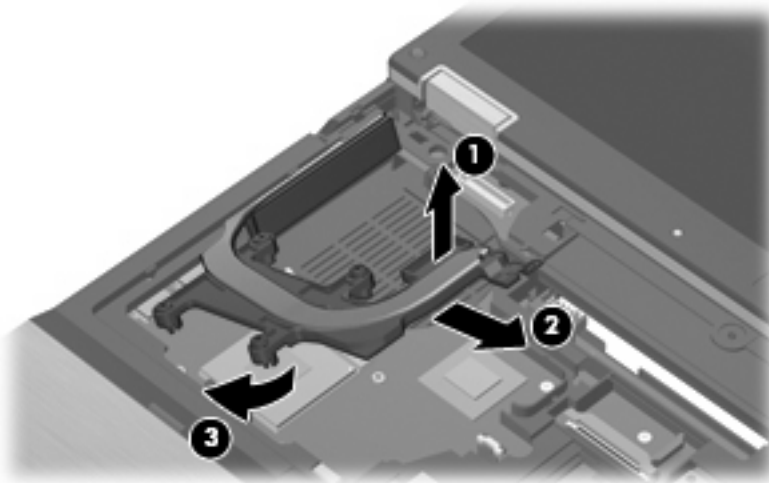

NOTE: The thermal material must be thoroughly cleaned from the surfaces of the heat sink and the system board each time the heat sink is removed. Thermal paste is used on the processor (1) and the section of the heat sink (1) that services it. Thermal pads are used on the Northbridge chip (2) and the section of the heat sink (2) that services it, and on the graphics subsystem chip (3) and the section of the heat sink (3) that services it. Replacement thermal material is included with all heat sink, system board, and processor spare part kits.

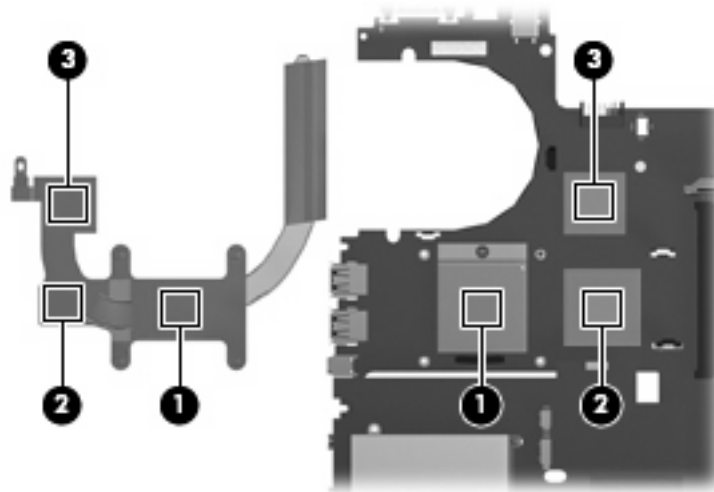

NOTE: Steps 6 through 8 apply only to computer models equipped with UMA graphics subsystem memory. See steps 1 through 5 for removing the heat sink on computer models with discrete graphics subsystem memory.

6. Following the 1, 2, 3, 4, sequence stamped into the heat sink, loosen the four Phillips PM2.5×11.0 screws **(1)** that secure the heat sink to the system board.

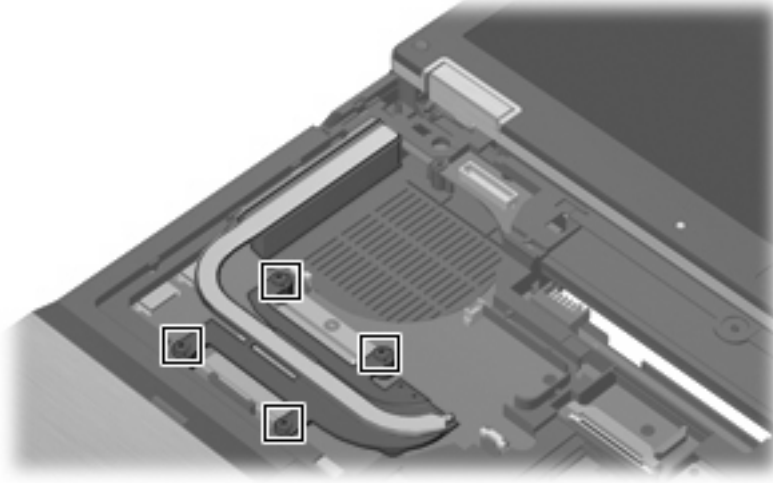

7. Lift the right side of the heat sink **(1)** until it rests at an angle.

 **NOTE:** Due to the adhesive quality of the thermal material located between the heat sink and system board components, it may be necessary to move the heat sink from side to side to detach it.

8. Release the heat sink **(2)** by sliding it to the right until it clears the left side of the top cover.

9. Remove the heat sink (3) by sliding it up and forward.

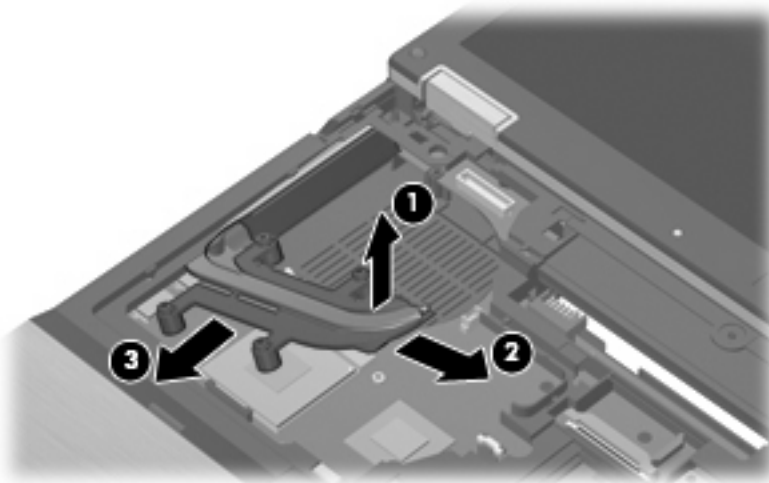

NOTE: The thermal material must be thoroughly cleaned from the surfaces of the heat sink and the system board each time the heat sink is removed. Thermal paste is used on the processor (1) and the section of the heat sink (1) that services it. Thermal pads are used on the Northbridge chip (2) and the section of the heat sink (2) that services it. Replacement thermal material is included with all heat sink, system board, and processor spare part kits.

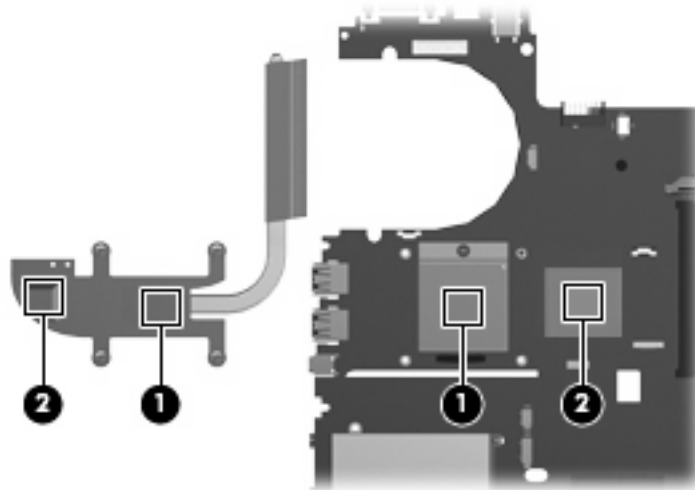

Reverse this procedure to install the heat sink.

Processor

 **NOTE:** All processor spare part kits include replacement thermal material.

Description	Spare part number
Intel Core 2 Duo 2.80-GHz processor (1066-MHz FSB, 6-MB L2 cache)	483199-001
Intel Core 2 Duo 2.53-GHz processor (1066-MHz FSB, 6-MB L2 cache)	483198-001
Intel Core 2 Duo 2.40-GHz processor (1066-MHz FSB, 3-MB L2 cache)	483197-001
Intel Core 2 Duo 2.26-GHz processor (1066-MHz FSB, 3-MB L2 cache)	483196-001

Before removing the processor, follow these steps:

1. Shut down the computer. If you are unsure whether the computer is off or in Hibernation, turn the computer on, and then shut it down through the operating system.
2. Disconnect all external devices connected to the computer.
3. Disconnect the power from the computer by first unplugging the power cord from the AC outlet and then unplugging the AC adapter from the computer.
4. Remove the battery (see [Battery on page 43](#)).
5. Remove the following:
 - a. Keyboard (see [Keyboard on page 57](#))
 - b. Switch cover (see [Switch cover on page 66](#))
 - c. Fan (see [Fan on page 69](#))
 - d. Heat sink (see [Heat sink on page 70](#))

Remove the processor:

1. Use a flat-bladed screwdriver to turn the processor locking screw **(1)** one-half turn counterclockwise until you hear a click.

2. Lift the processor (2) straight up and remove it.

 **NOTE:** When you install the processor, the gold triangle (3) on the processor must be aligned with the triangle (4) embossed on the processor slot.

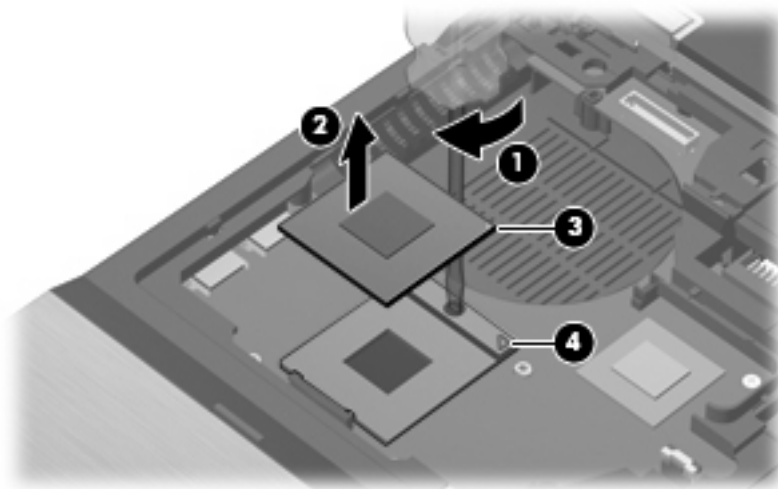

Reverse this procedure to install the processor.

Display assembly

Description	Spare part number
14.1-inch, WXGA AntiGlare LED display assembly for use on computer models equipped with a webcam (includes three WLAN antenna cables, two WWAN antenna cables, and two microphones)	487433-001
14.1-inch, WXGA AntiGlare LED display assembly for use on computer models not equipped with a webcam (includes three WLAN antenna cables, two WWAN antenna cables, and two microphones)	483202-001
14.1-inch, WXGA+ AntiGlare display assembly for use on computer models equipped with a webcam (includes three WLAN antenna cables, two WWAN antenna cables, and two microphones)	487435-001
14.1-inch, WXGA+ AntiGlare display assembly for use on computer models not equipped with a webcam (includes three WLAN antenna cables, two WWAN antenna cables, and two microphones)	483201-001
14.1-inch, WXGA AntiGlare display assembly for use on computer models equipped with a webcam (includes three WLAN antenna cables, two WWAN antenna cables, and two microphones)	487434-001
14.1-inch, WXGA AntiGlare display assembly for use on computer models not equipped with a webcam (includes three WLAN antenna cables, two WWAN antenna cables, and two microphones)	483200-001

Before removing the display assembly, follow these steps:

1. Shut down the computer. If you are unsure whether the computer is off or in Hibernation, turn the computer on, and then shut it down through the operating system.
2. Disconnect all external devices connected to the computer.
3. Disconnect the power from the computer by first unplugging the power cord from the AC outlet and then unplugging the AC adapter from the computer.
4. Remove the battery (see [Battery on page 43](#)).
5. Disconnect the wireless antenna cables from the WLAN module (see [WLAN module on page 62](#)).
6. Remove the keyboard (see [Keyboard on page 57](#)).
7. Remove the switch cover (see [Switch cover on page 66](#)).

Remove the display assembly:

1. Close the computer and turn it upside down, with the rear panel toward you.

2. Remove the following:

(1) Two round rubber screw covers. Screw covers are available in the Rubber Kit, spare part number 482966-001.

(2) Two wedge-shaped rubber screw covers. Screw covers are available in the Rubber Kit, spare part number 482966-001.

(3) Four Torx T8M2.5×7.0 screws that secure the display assembly to the computer.

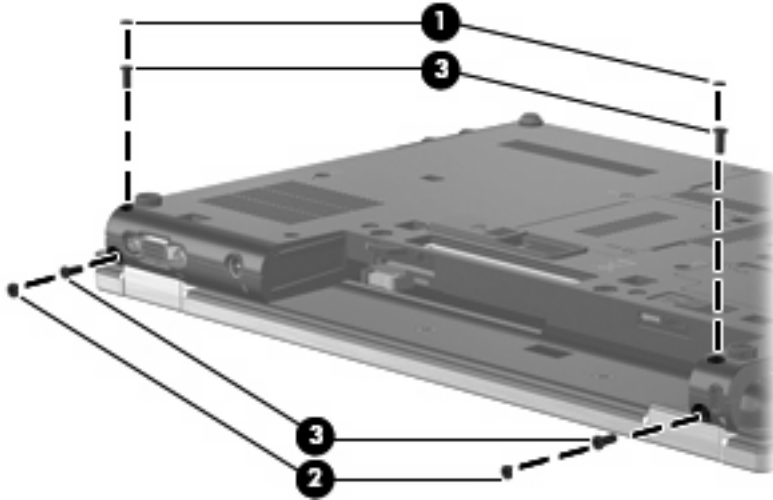

3. Turn the computer right-side up, with the front toward you.

4. Open the computer as far as possible.

5. Disconnect the display panel cable (1) from the system board.

6. Disconnect the microphone cable (2) from the system board.

7. Remove the wireless antenna cables (3) from the clips and routing channels built into the top cover.

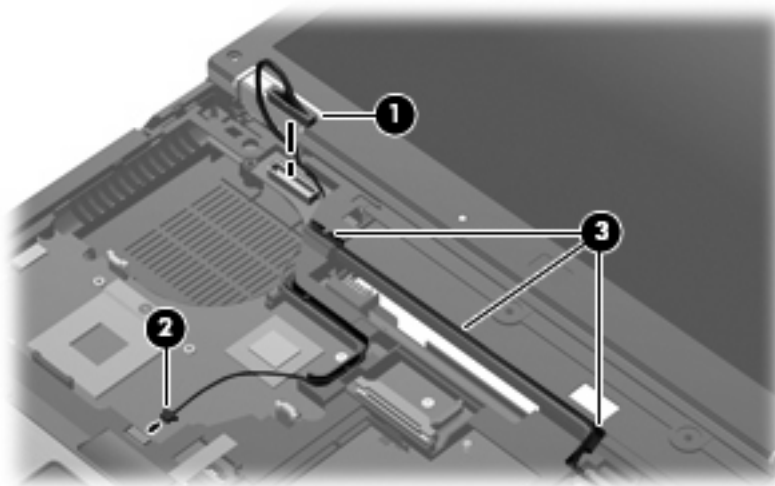

8. Disconnect the webcam cable (1) from the system board.

9. Remove the wireless antenna cables (2) from the clips and routing channels built into the top cover.

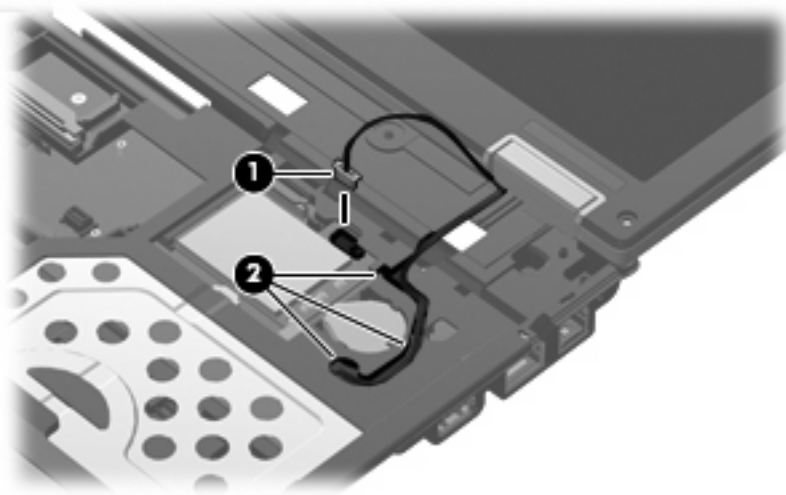

△ **CAUTION:** The display assembly will be unsupported when the following screws are removed. To prevent damage to the display assembly, support it before removing the screws.

10. Remove the two T8M2.5×7.0 screws (1) that secure the display assembly to the computer.
11. Remove the display assembly (2) by lifting it straight up.

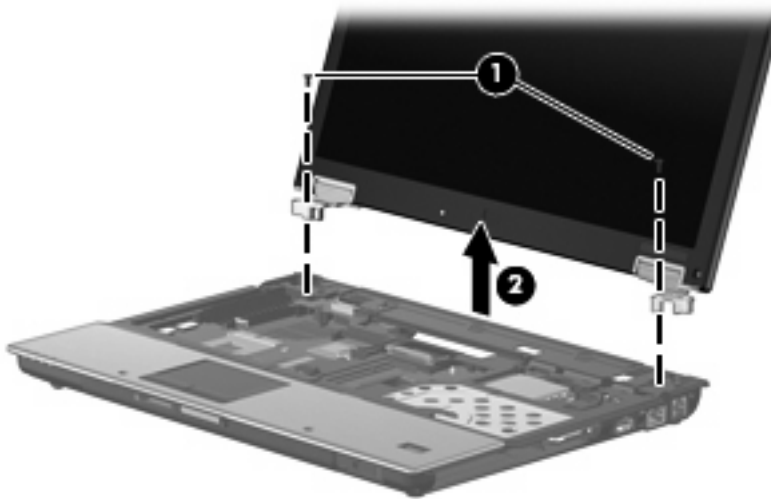

12. If it is necessary to replace the display bezel or display hinges, remove the four rubber screw covers **(1)** and the four Phillips PM2.5×7.0 screws **(2)** that secure the display bezel to the display assembly. The rubber screw covers are available in the Rubber Kit, spare part number 482966-001.

 **NOTE:** See [Display inverter on page 45](#) for procedures on removing the display inverter.

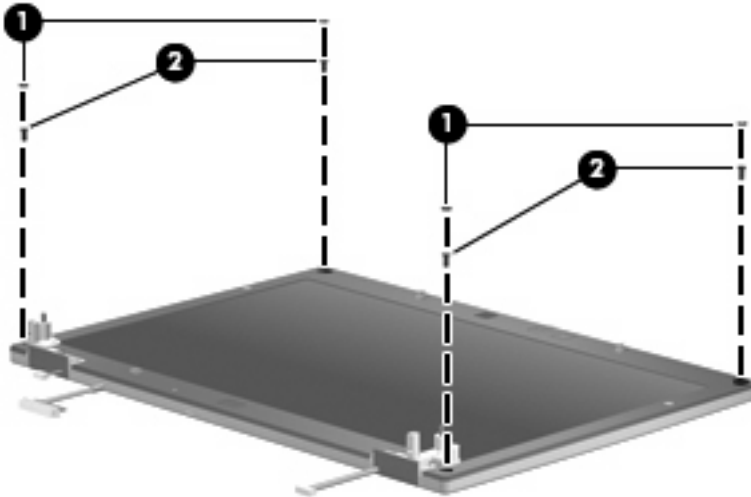

13. Flex the inside edges of the left and right sides **(1)** and the top and bottom sides **(2)** of the display bezel until the bezel disengages from the display enclosure.
14. Remove the display bezel **(3)**. The display bezel is available using spare part numbers 488189-001 (for use with computer models equipped with a webcam) and 488190-001 (for use with computer models not equipped with a webcam).

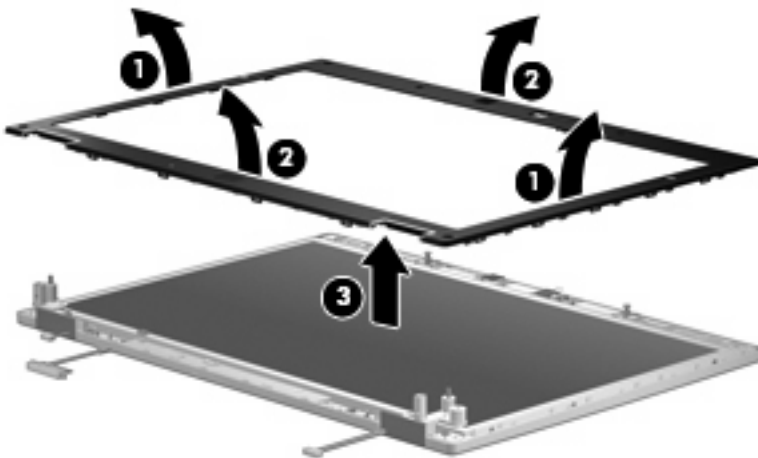

15. If it is necessary to replace the display hinges, remove the two Phillips PM2.5×7.0 screws **(1)** that secure the display hinges to the display enclosure.

16. Remove the display hinges (2). The left and right display hinges are included in the Display Hinge Kit, spare part number 482967-001.

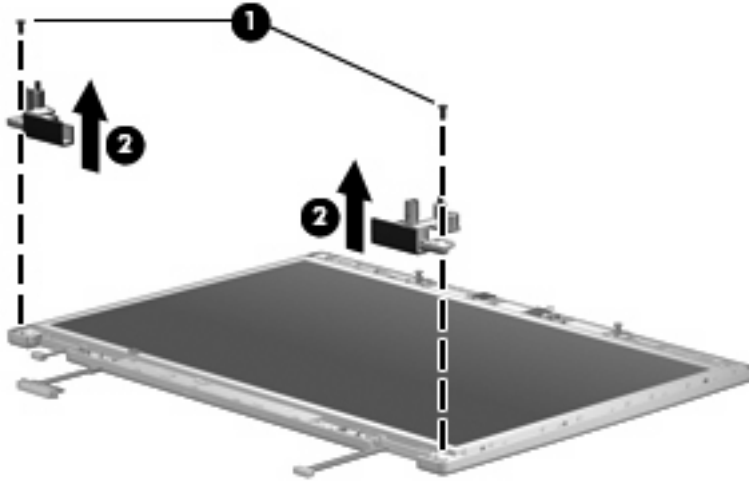

Reverse this procedure to reassemble and install the display assembly.

Top cover

Description	Spare part number
Top cover (includes TouchPad buttons)	486303-001

Before removing the top cover, follow these steps:

1. Shut down the computer. If you are unsure whether the computer is off or in Hibernation, turn the computer on, and then shut it down through the operating system.
2. Disconnect all external devices connected to the computer.
3. Disconnect the power from the computer by first unplugging the power cord from the AC outlet and then unplugging the AC Adapter from the computer.
4. Remove the battery (see [Battery on page 43](#)).
5. Remove the following:
 - a. Hard drive (see [Hard drive on page 49](#))
 - b. Keyboard (see [Keyboard on page 57](#))
 - c. Switch cover (see [Switch cover on page 66](#))
 - d. Display assembly (see [Display assembly on page 77](#))

Remove the top cover:

1. Turn the computer upside down, with the front toward you.

2. Remove the following:

(1) Two round rubber screw covers on the front edge of the base enclosure. Rubber screw covers are available in the Rubber Kit, spare part number 482968-001.

(2) Two cup-shaped rubber screw covers on the right edge of the base enclosure. Rubber screw covers are available in the Rubber Kit, spare part number 482968-001.

(3) Seven Torx8 T8M2.5×7.0 screws.

(4) One Phillips PM2.0×5.0 screw.

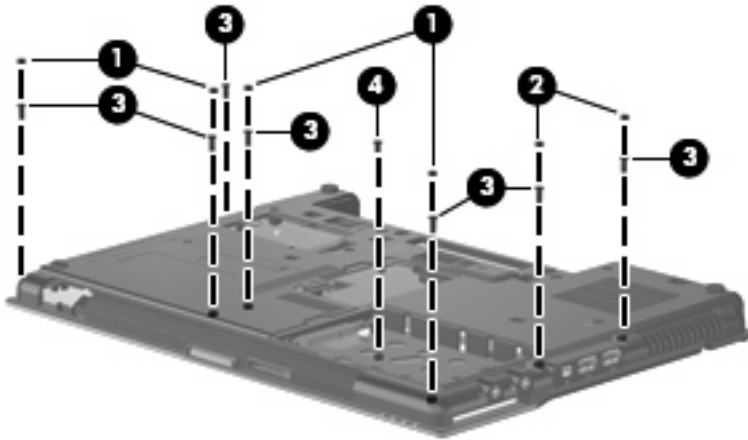

3. Turn the computer right-side up, with the front toward you.

4. Release the ZIF connector (1) to which the TouchPad cable is attached, and disconnect the TouchPad cable from the system board.

5. Release the ZIF connector (2) to which the audio/ExpressCard assembly cable is attached, and disconnect the audio/ExpressCard assembly cable from the system board.

6. Release the ZIF connector (3) to which the fingerprint reader board cable is attached, and disconnect the fingerprint reader board cable from the system board.

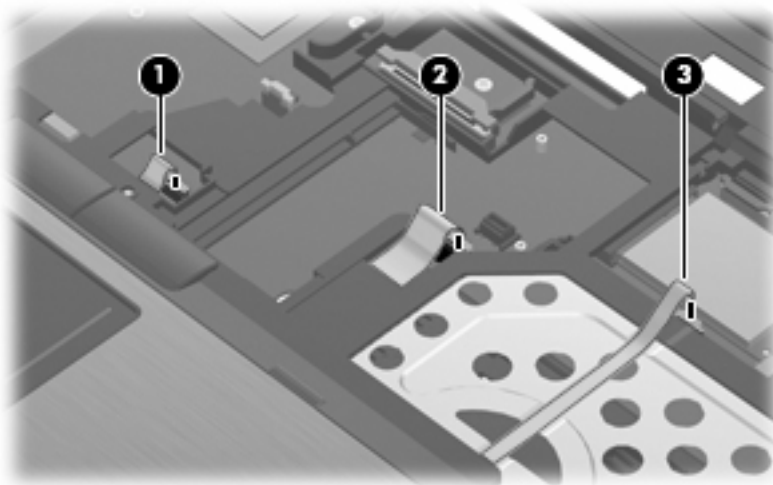

7. Lift the rear edge of the top cover (1) until it detaches from the base enclosure.

8. Remove the top cover (**2**) by lifting it straight up.

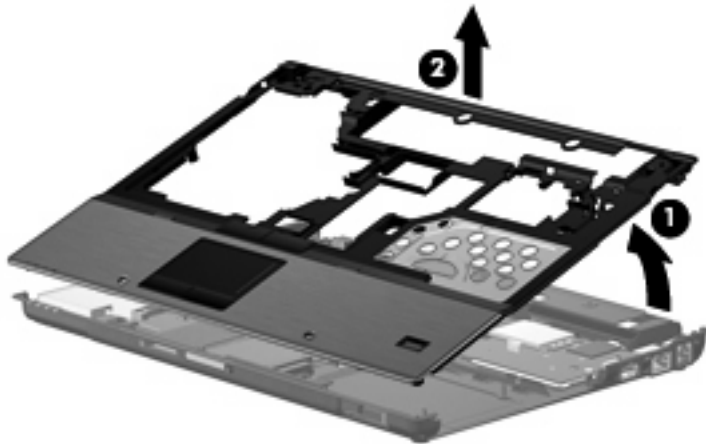

Reverse this procedure to install the top cover.

TouchPad

Description	Spare part number
TouchPad (includes cable and TouchPad button board and cable)	486306-001

Before removing the TouchPad, follow these steps:

1. Shut down the computer. If you are unsure whether the computer is off or in Hibernation, turn the computer on, and then shut it down through the operating system.
2. Disconnect all external devices connected to the computer.
3. Disconnect the power from the computer by first unplugging the power cord from the AC outlet and then unplugging the AC Adapter from the computer.
4. Remove the battery (see [Battery on page 43](#)).
5. Remove the following:
 - a. Hard drive (see [Hard drive on page 49](#))
 - b. Keyboard (see [Keyboard on page 57](#))
 - c. Switch cover (see [Switch cover on page 66](#))
 - d. Display assembly (see [Display assembly on page 77](#))
 - e. Top cover (see [Top cover on page 82](#))

Remove the TouchPad:

1. Turn the top cover upside down, with the front toward you.
2. Remove the four Phillips PM2.0×3.0 screws (**1**) that secure the TouchPad bracket to the top cover.
3. Release the TouchPad bracket (**2**) by sliding it toward the back of the top cover.

4. Remove the TouchPad bracket (3) by lifting it straight up.

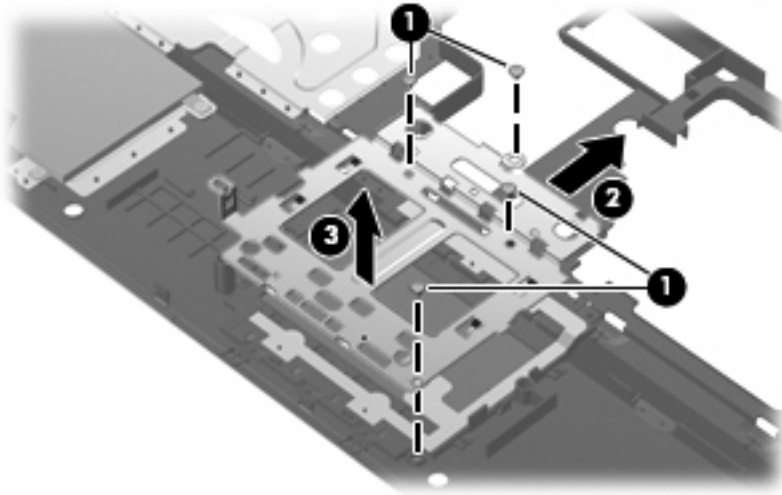

5. Release the ZIF connector (1) to which the TouchPad button board cable is attached, and disconnect the TouchPad button board cable from the TouchPad board.
6. Remove the TouchPad board (2) by lifting it straight up.

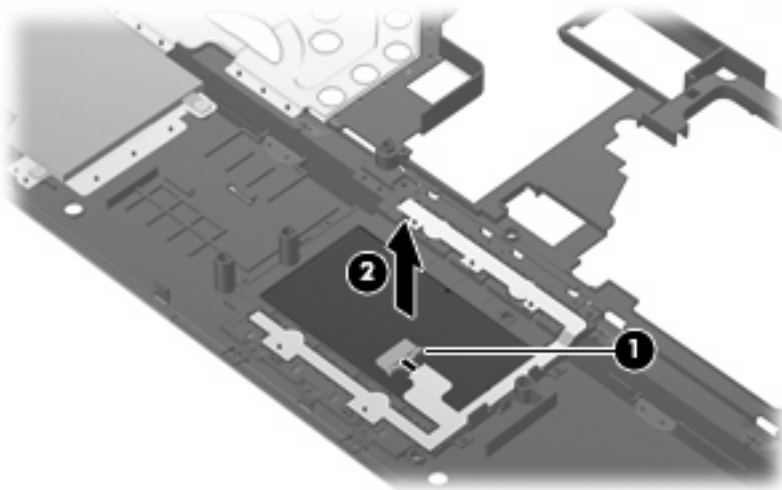

Reverse this procedure to install the TouchPad.

Fingerprint reader board

Description	Spare part number
Fingerprint reader board (includes cable)	486309-001

Before removing the fingerprint reader board, follow these steps:

1. Shut down the computer. If you are unsure whether the computer is off or in Hibernation, turn the computer on, and then shut it down through the operating system.
2. Disconnect all external devices connected to the computer.
3. Disconnect the power from the computer by first unplugging the power cord from the AC outlet and then unplugging the AC Adapter from the computer.
4. Remove the battery (see [Battery on page 43](#)).
5. Remove the following:
 - a. Hard drive (see [Hard drive on page 49](#))
 - b. Keyboard (see [Keyboard on page 57](#))
 - c. Switch cover (see [Switch cover on page 66](#))
 - d. Display assembly (see [Display assembly on page 77](#))
 - e. Top cover (see [Top cover on page 82](#))
 - f. Audio/ExpressCard assembly (see [Audio/ExpressCard assembly on page 89](#))

Remove the fingerprint reader board:

1. Remove the fingerprint reader board cable (**1**) from the opening in the top cover.
2. Remove the fingerprint reader board (**2**) by lifting it straight up. The fingerprint reader board is attached to the top cover using double-sided tape.

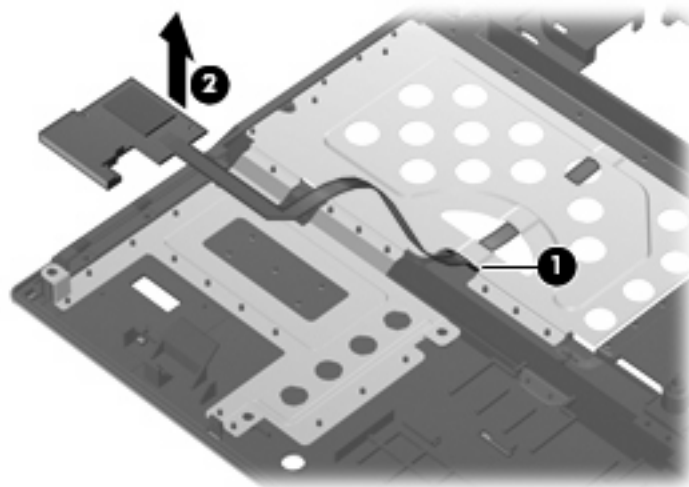

Reverse this procedure to install the fingerprint reader board.

Bluetooth module cable

 **NOTE:** The Bluetooth module spare part kit does not include a Bluetooth module cable. The Bluetooth module cable is included in the Cable Kit, spare part number 487432-001.

Before removing the Bluetooth module cable, follow these steps:

1. Shut down the computer. If you are unsure whether the computer is off or in Hibernation, turn the computer on, and then shut it down through the operating system.
2. Disconnect all external devices connected to the computer.
3. Disconnect the power from the computer by first unplugging the power cord from the AC outlet and then unplugging the AC Adapter from the computer.
4. Remove the battery (see [Battery on page 43](#)).
5. Remove the following:
 - a. Hard drive (see [Hard drive on page 49](#))
 - b. Keyboard (see [Keyboard on page 57](#))
 - c. Switch cover (see [Switch cover on page 66](#))
 - d. Display assembly (see [Display assembly on page 77](#))
 - e. Top cover (see [Top cover on page 82](#))

Remove the Bluetooth module cable:

1. Disconnect the Bluetooth module cable **(1)** from the system board.
2. Detach the Bluetooth module cable **(2)** from the speaker. The Bluetooth module cable is attached to the speaker using double-sided tape.

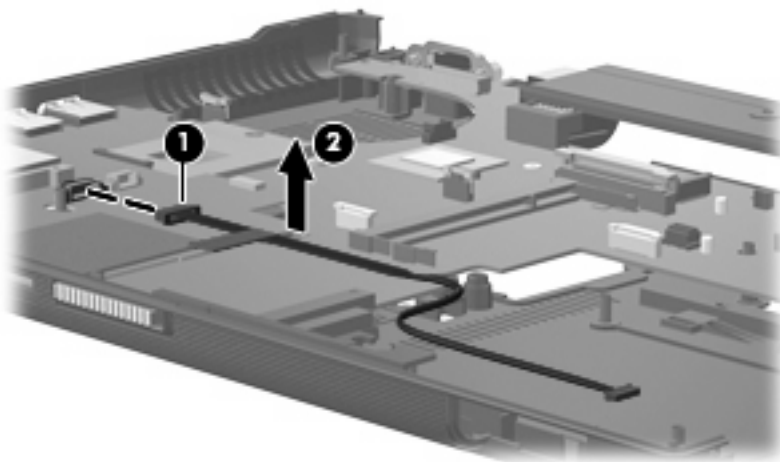

Reverse this procedure to install the Bluetooth module cable.

Speaker

Description	Spare part number
Speaker	486308-001

Before removing the speaker, follow these steps:

1. Shut down the computer. If you are unsure whether the computer is off or in Hibernation, turn the computer on, and then shut it down through the operating system.
2. Disconnect all external devices connected to the computer.
3. Disconnect the power from the computer by first unplugging the power cord from the AC outlet and then unplugging the AC Adapter from the computer.
4. Remove the battery (see [Battery on page 43](#)).
5. Remove the following:
 - a. Hard drive (see [Hard drive on page 49](#))
 - b. Keyboard (see [Keyboard on page 57](#))
 - c. Switch cover (see [Switch cover on page 66](#))
 - d. Display assembly (see [Display assembly on page 77](#))
 - e. Top cover (see [Top cover on page 82](#))
 - f. Bluetooth module cable (see [Bluetooth module cable on page 87](#))

Remove the speaker:

1. Disconnect the speaker cable (1) from the system board.
2. Remove the Torx8 T8M2.5×7.0 screw (2) that secures the speaker to the base enclosure.
3. Remove the speaker (3) by lifting it straight up.

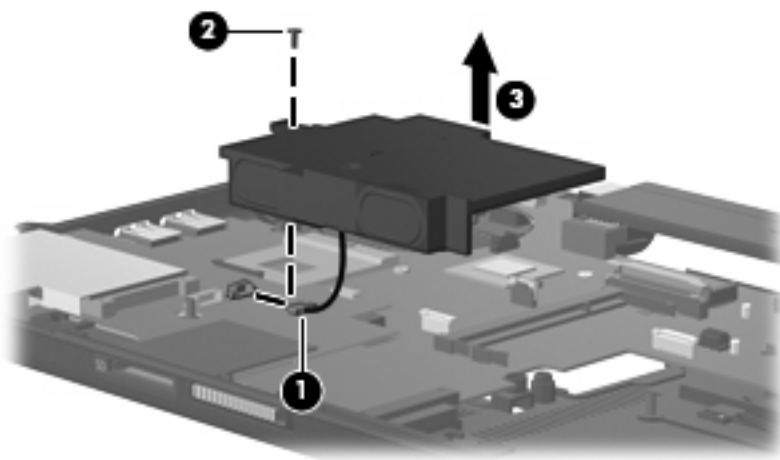

Reverse this procedure to install the speaker.

Audio/ExpressCard assembly

Description	Spare part number
Audio/ExpressCard assembly (includes ExpressCard slot, cable, headphone and microphone connectors, and SD card reader slot)	482959-001

Before removing the audio/ExpressCard assembly, follow these steps:

1. Shut down the computer. If you are unsure whether the computer is off or in Hibernation, turn the computer on, and then shut it down through the operating system.
2. Disconnect all external devices connected to the computer.
3. Disconnect the power from the computer by first unplugging the power cord from the AC outlet and then unplugging the AC Adapter from the computer.
4. Remove the battery (see [Battery on page 43](#)).
5. Remove the following:
 - a. Hard drive (see [Hard drive on page 49](#))
 - b. Keyboard (see [Keyboard on page 57](#))
 - c. Switch cover (see [Switch cover on page 66](#))
 - d. Display assembly (see [Display assembly on page 77](#))
 - e. Top cover (see [Top cover on page 82](#))
 - f. Bluetooth module cable (see [Bluetooth module cable on page 87](#))
 - g. Speaker (see [Speaker on page 88](#))

Remove the audio/ExpressCard assembly:

1. Release the ZIF connector **(1)** to which the audio/ExpressCard assembly cable is attached, and disconnect the audio/ExpressCard assembly cable from the system board.
2. Lift the right side of the audio/ExpressCard assembly **(2)** to disconnect it from the system board.

3. Remove the audio/ExpressCard assembly (3) by sliding it up and to the right.

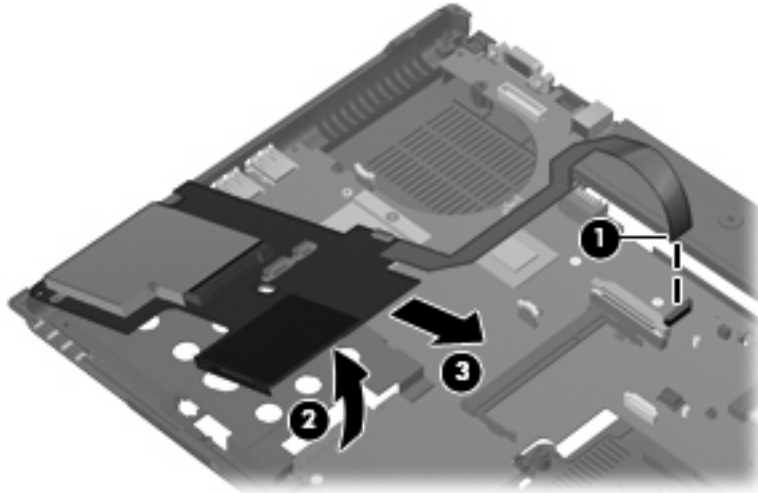

Reverse this procedure to install the audio/ExpressCard assembly.

Modem module cable

 **NOTE:** The modem module spare part kits do not include a modem module cable. The modem module cable is included in the Cable Kit, spare part number 487432-001. The modem module cable includes an RJ-11 connector.

Before removing the modem module cable, follow these steps:

1. Shut down the computer. If you are unsure whether the computer is off or in Hibernation, turn the computer on, and then shut it down through the operating system.
2. Disconnect all external devices connected to the computer.
3. Disconnect the power from the computer by first unplugging the power cord from the AC outlet and then unplugging the AC Adapter from the computer.
4. Remove the battery (see [Battery on page 43](#)).
5. Remove the following:
 - a. Hard drive (see [Hard drive on page 49](#))
 - b. Keyboard (see [Keyboard on page 57](#))
 - c. Switch cover (see [Switch cover on page 66](#))
 - d. Display assembly (see [Display assembly on page 77](#))
 - e. Top cover (see [Top cover on page 82](#))

Remove the modem module cable:

1. Disconnect the modem module cable (1) from the system board.

2. Remove the RJ-11 connector (2) from the clip built into the base enclosure.

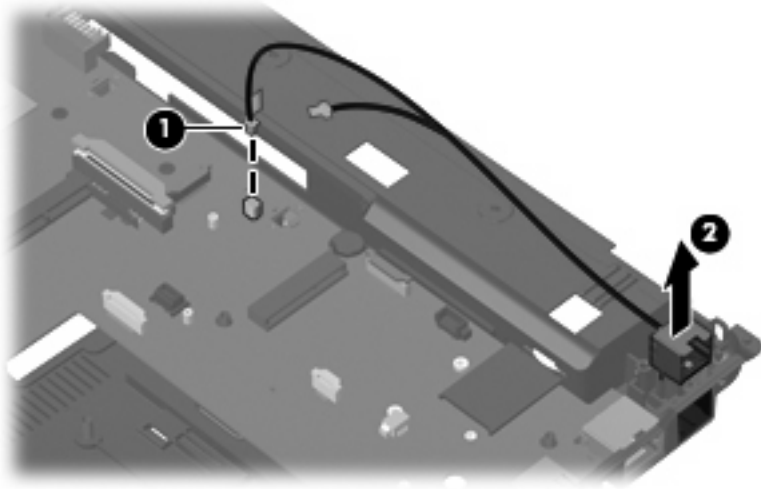

Reverse this procedure to install the modem module cable.

System board

 **NOTE:** All system board spare part kits include replacement thermal material.

Description	Spare part number
For use only with computer models with discrete graphics subsystem memory (includes 256 MB of graphics subsystem memory)	486300-001
For use only with computer models with discrete graphics subsystem memory (includes 128 MB of graphics subsystem memory)	486299-001
For use only with computer models with UMA graphics subsystem memory	486301-001

Before removing the system board, follow these steps:

1. Shut down the computer. If you are unsure whether the computer is off or in Hibernation, turn the computer on, and then shut it down through the operating system.
2. Disconnect all external devices connected to the computer.
3. Disconnect the power from the computer by first unplugging the power cord from the AC outlet and then unplugging the AC adapter from the computer.
4. Remove the battery (see [Battery on page 43](#)).
5. Remove the following components:
 - a. Bluetooth module (see [Bluetooth module on page 47](#))
 - b. Hard drive (see [Hard drive on page 49](#))
 - c. Optical drive (see [Optical drive on page 51](#)) or upgrade bay device (see [Upgrade bay device on page 52](#))
 - d. Keyboard (see [Keyboard on page 57](#))
 - e. Switch cover (see [Switch cover on page 66](#))
 - f. Display assembly (see [Display assembly on page 77](#))
 - g. Top cover (see [Top cover on page 82](#))
 - h. Bluetooth module cable (see [Bluetooth module cable on page 87](#))
 - i. Speaker (see [Speaker on page 88](#))
 - j. Audio/ExpressCard assembly (see [Audio/ExpressCard assembly on page 89](#))

When replacing the system board, be sure that the following components are removed from the defective system board and installed on the replacement system board:

- Memory module (see [Expansion memory module on page 54](#) and [Primary memory module on page 59](#))
- WWAN module (see [WWAN module on page 55](#))
- Modem module (see [Modem module on page 61](#))

- WLAN module (see [WLAN module on page 62](#))
- RTC battery (see [RTC battery on page 65](#))
- Fan (see [Fan on page 69](#))
- Heat sink (see [Heat sink on page 70](#))
- Processor (see [Processor on page 75](#))

Remove the system board:

1. Disconnect the modem module cable (1) from the system board.
2. Remove the three Phillips PM2.5×4.0 screws (2) that secure the system board to the base enclosure.

 **NOTE:** Computer models equipped with UMA graphics subsystem memory will have a fourth Phillips PM2.5×4.0 screw (3) securing the system board to the base enclosure.

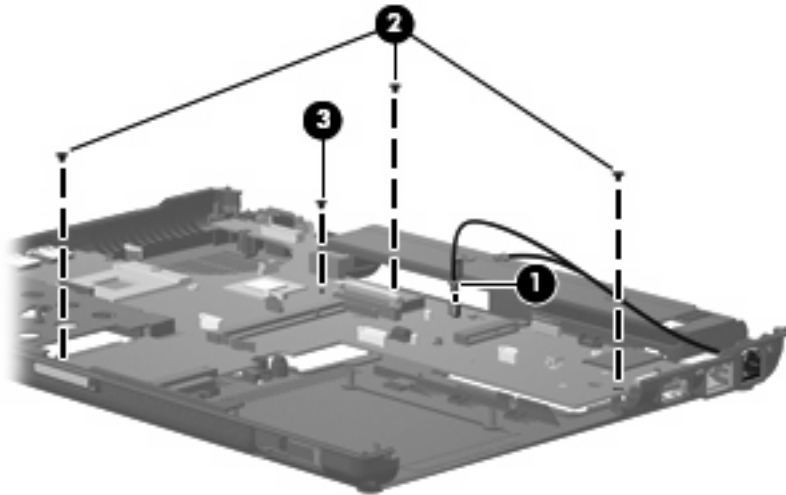

3. Use the optical drive connector (1) to lift the right edge of the system board (2) until it rests at an angle.
4. Remove the system board (3) from the base enclosure by sliding it up and to the right at an angle.

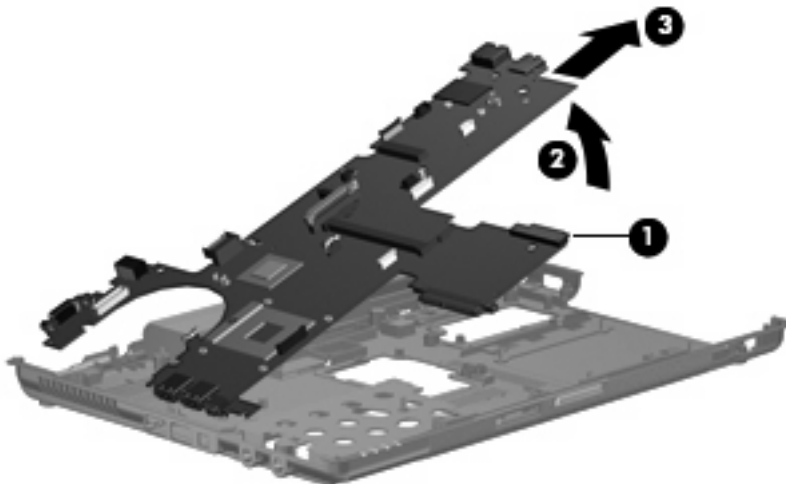

Reverse the preceding procedure to install the system board.

5 Computer Setup

This user guide describes features that are common to most models. Some features may not be available on your computer.

Starting Computer Setup

Computer Setup is a preinstalled, ROM-based utility that can be used even when the operating system is not working or will not load.

 **NOTE:** Some of the Computer Setup menu items listed in this guide may not be supported by your computer.

NOTE: An external keyboard or mouse connected to a USB port can be used with Computer Setup only if USB legacy support is enabled.

To start Computer Setup, follow these steps:

1. Turn on or restart the computer, and then press **esc** while the “Press the ESC key for Startup Menu” message is displayed at the bottom of the screen.
2. Press **f10** to enter BIOS Setup.

Using Computer Setup

Navigating and selecting in Computer Setup

The information and settings in Computer Setup are accessed from the File, Security, Diagnostics, and System Configuration menus.

To navigate and select in Computer Setup, follow these steps:

1. Turn on or restart the computer, and then press **esc** while the “Press the ESC key for Startup Menu” message is displayed at the bottom of the screen.

 **NOTE:** You can use either a pointing device (TouchPad, pointing stick, or USB mouse) or the keyboard to navigate and make selections in Computer Setup.

- To select a menu or a menu item, use the keyboard arrow keys and then press **enter**, or use a pointing device to click the item.
- To scroll up and down, click the plus sign (+) or the minus sign (-) in the upper-right corner of the screen.
- To close open dialog boxes and return to the main Computer Setup screen, press **esc**, and then follow the on-screen instructions.

2. Press **f10** to enter BIOS Setup.

3. Select the **File**, **Security**, **Diagnostics**, or **System Configuration** menu.

To exit Computer Setup menus, choose one of the following methods:

- To exit Computer Setup menus without saving your changes, click **Exit** in the lower-left corner of the screen, and then follow the on-screen instructions.

– or –

Use the arrow keys to select **File > Ignore changes and exit**, and then press **enter**.

– or –

- To save your changes and exit Computer Setup menus, click **Save** in the lower-left corner of the screen, and then follow the on-screen instructions.

– or –

Use the arrow keys to select **File > Save changes and exit**, and then press **enter**.

Your changes go into effect when the computer restarts.

Restoring factory settings in Computer Setup

 **NOTE:** Restoring defaults will not change the hard drive mode.

To return all settings in Computer Setup to the values that were set at the factory, follow these steps:

1. Turn on or restart the computer, and then press **esc** while the “Press the ESC key for Startup Menu” message is displayed at the bottom of the screen.
2. Press **f10** to enter BIOS Setup.
3. Use a pointing device or the arrow keys to select **File > Restore defaults**.
4. Follow the on-screen instructions.
5. To save your changes and exit, click **Save** in the lower-left corner of the screen, and then follow the on-screen instructions.

– or –

Use the arrow keys to select **File > Save changes and exit**, and then press **enter**.

Your changes go into effect when the computer restarts.

 **NOTE:** Your password settings and security settings are not changed when you restore the factory settings.

Computer Setup menus

The menu tables in this section provide an overview of Computer Setup options.

 **NOTE:** Some of the Computer Setup menu items listed in this chapter may not be supported by your computer.

File menu

Select	To do this
System Information	<ul style="list-style-type: none">View identification information for the computer and the batteries in the system.View specification information for the processor, cache and memory size, system ROM, video revision, and keyboard controller version.
Restore defaults	Replace the configuration settings in Computer Setup with the original factory settings. (Password settings and security settings are not changed when you restore the factory settings.)
Ignore changes and exit	Cancel any changes entered during the current session. Then exit and restart the computer.
Save changes and exit	Save changes and exit Save any changes entered during the current session. Then exit and restart the computer. Your changes go into effect when the computer restarts.

Security menu

 **NOTE:** Some of the menu items listed in this section may not be supported by your computer.

Select	To do this
Setup BIOS Administrator Password	Set up a BIOS administrator password.
User Management (requires an administrator password)	<ul style="list-style-type: none">Create a new BIOS user account.View a list of ProtectTools users.
Password Policy (requires an administrator password)	Revise password policy criteria.
HP SpareKey	Enable/disable HP SpareKey (enabled by default).
Always Prompt for HP SpareKey Enrollment	Enable/disable HP SpareKey enrollment (enabled by default).
Fingerprint Reset on Reboot (if Present)	Enable/disable the fingerprint reader (select models only; disabled by default).
Allow reset of HP ProtectTools security keys	Enable/disable reset of HP ProtectTools security keys.
Change Password	Enter, change, or delete a BIOS administrator password.
HP SpareKey Enrollment	Enroll or reset HP SpareKey, which is a set of security questions and answers used if you forget your password.

Select	To do this
DriveLock Passwords	<ul style="list-style-type: none"> • Enable/disable DriveLock on any computer hard drive (enabled by default). • Change a DriveLock user password or master password. <p>NOTE: DriveLock settings are accessible only when you enter Computer Setup by turning on (not restarting) the computer.</p>
Automatic DriveLock	Enable/disable Automatic DriveLock support.
Disk Sanitizer	Run Disk Sanitizer to destroy all existing data on the primary hard drive.
	CAUTION: If you run Disk Sanitizer, the data on the primary hard drive is destroyed permanently.
System IDs	Enter a user-defined computer asset tracking number and ownership tag.
Always Prompt for HP SpareKey Enrollment	Enable/disable a prompt for HP SpareKey enrollment.

Diagnostics menu

Select	To do this
System Diagnostics menu	<ul style="list-style-type: none"> • F1 System Information—Displays the following information: <ul style="list-style-type: none"> ◦ Identification information for the computer and the batteries in the system. ◦ Specification information for the processor, cache and memory size, system ROM, video revision, and keyboard controller version. • F2 Start-up Test—Verifies the system components needed for starting the computer. • F3 Run-In Test—Runs a comprehensive check on system memory. • F4 Hard Disk Test—Runs a comprehensive self-test on any hard drive in the system.

System Configuration menu

 **NOTE:** Some of the menu items listed in this section may not be supported by your computer.

Select	To do this
Language	Change the Computer Setup language.
Boot Options	<ul style="list-style-type: none">• Set a Startup Menu delay (in seconds).• Enable/disable Custom Logo (disabled by default).• Enable/disable Display Diagnostic URL (disabled by default).• Enable/disable CD-ROM boot (enabled by default).• Enable/disable SD Card boot (enabled by default).• Enable/disable diskette boot (enabled by default).• Enable/disable boot from Extensible Firmware Interface (EFI) File (select models only; enabled by default).• Enable/disable internal network adapter boot and set the Preboot eXecution Environment (PXE) (enabled by default).• Set the Express Boot Popup delay in seconds.• Set the boot order.
Device Configurations	<ul style="list-style-type: none">• Enable/disable USB legacy support (enabled by default). When enabled, USB legacy support allows the following:<ul style="list-style-type: none">◦ Use of a USB keyboard in Computer Setup even when a Windows® operating system is not running.◦ Startup from bootable USB devices, including a hard drive, diskette drive, or optical drive connected by a USB port to the computer.• Select a parallel port mode: ECP (Enhanced Capabilities Port), standard, bidirectional, or EPP (Enhanced Parallel Port).• Enable/disable BIOS DMA data transfers (select models only; enabled by default).• Enable/disable fan always on while connected to an AC outlet (disabled by default).• Enable/disable LAN Power Save. When enabled, saves power by turning off the LAN when not in use (enabled by default).• Enable/disable Data Execution Prevention. When enabled, the processor can disable some virus code execution, which helps to improve computer security.• SATA (Serial Advanced Technology Attachment) device mode. The following options are available:<ul style="list-style-type: none">◦ AHCI (Advanced Host Controller Interface)◦ IDE (Integrated Drive Electronics)◦ RAID (Redundant Array of Independent Disks)<p>NOTE: Availability of the options above varies by computer model.</p>• Enable/disable secondary battery fast charge (enabled by default).• Enable/disable HP QuickLook (enabled by default).

Select	To do this
	<ul style="list-style-type: none"> • Enable/disable Virtualization Technology (select models only; enabled by default). • Enable/disable TXT (Intel® Trusted Execution Technology) (select models only; enabled by default). • Enable/disable Dual Core CPU (select models only; enabled by default).
Built-In Device Options	<ul style="list-style-type: none"> • Enable/disable the wireless button state (enabled by default). • Enable/disable embedded WWAN device radio (select models only; enabled by default). • Enable/disable embedded Bluetooth® device radio (enabled by default). • Enable/disable the Network Interface Controller (LAN) (enabled by default). • Set the wake on LAN state. Options include the following: <ul style="list-style-type: none"> ◦ Disabled ◦ Boot to Network (set by default) ◦ Follow Boot Order • Enable/disable the fingerprint device (enabled by default). • Enable/disable a modem device (enabled by default).
Port Options (all are enabled by default)	<p>NOTE: All port options are enabled by default.</p> <ul style="list-style-type: none"> • Enable/disable the serial port. • Enable/disable the parallel port. • Enable/disable the flash media reader. • Enable/disable the USB port. <p>CAUTION: Disabling the USB port also disables MultiBay devices and ExpressCard devices on the advanced port replicator.</p> <ul style="list-style-type: none"> • Enable/disable the 1394 port.
Set Security Level	Change, view, or hide security levels for all BIOS menu items.
Restore Security Defaults	Restore the default security settings.

6 Specifications

Computer specifications

	Metric	U.S.
Dimensions		
Depth	24.30 cm	9.57 in
Width	33.10 cm	13.03 in
Height (front to rear)	3.13 to 3.41 cm	1.23 to 1.34 in
Weight (computer equipped with an optical drive, WXGA display assembly, 1 memory module, WLAN module, and 6-cell battery)	2.40 kg	5.29 lbs
Weight (computer equipped with the optical drive weight saver, WXGA display assembly, 1 memory module, WLAN module, and 4-cell battery)	2.10 kg	4.63 lbs
Input power		
Operating voltage	19.0 V dc @ 4.74 A – 90 W	
Operating current	4.74 A	
Temperature		
Operating (not writing to optical disc)	0°C to 35°C	32°F to 95°F
Operating (writing to optical disc)	5°C to 35°C	41°F to 95°F
Nonoperating	-20°C to 60°C	-4°F to 140°F
Relative humidity		
Operating	10% to 90%	
Nonoperating	5% to 95%	
Maximum altitude (unpressurized)		
Operating	-15 m to 3,048 m	-50 ft to 10,000 ft
Nonoperating	-15 m to 12,192 m	-50 ft to 40,000 ft
Shock		
Operating	125 g, 2 ms, half-sine	
Nonoperating	200 g, 2 ms, half-sine	
Random vibration		

	Metric	U.S.
Operating	0.75 g zero-to-peak, 10 Hz to 500 Hz, 0.25 oct/min sweep rate	
Nonoperating	1.50 g zero-to-peak, 10 Hz to 500 Hz, 0.5 oct/min sweep rate	

NOTE: Applicable product safety standards specify thermal limits for plastic surfaces. The computer operates well within this range of temperatures.

14.1-inch, WXGA display specifications

	Metric	U.S.
Dimensions		
Height	27.94 cm	11.0 in
Width	20.83 cm	8.2 in
Diagonal	35.56 cm	14.1 in
Number of colors	Up to 16.8 million	
Contrast ratio	250:1 (typical)	
Brightness	180 nits (typical)	
Pixel resolution		
Pitch	0.279 × 0.279 mm	
Format	1280 × 800	
Configuration	RGB vertical stripe	
Backlight	Edge lit	
Character display	80 × 25	
Total power consumption	4.0 W	
Viewing angle	+/-40 horizontal, +20/-40° vertical (typical)	

Hard drive specifications

	250-GB*	160-GB*	120-GB*
Dimensions			
Height	9.5 mm	9.5 mm	9.5 mm
Width	70 mm	70 mm	70 mm
Weight	101 g	101 g	101 g
Interface type	SATA	SATA	SATA
Transfer rate	100 MB/sec	100 MB/sec	100 MB/sec
Security	ATA security	ATA security	ATA security
Seek times (typical read, including setting)			
Single track	3 ms	3 ms	3 ms
Average	13 ms	13 ms	13 ms
Maximum	24 ms	24 ms	24 ms
Logical blocks	488,376,280	312,560,640	234,420,480
Disc rotational speed	5400 rpm	7200 rpm and 5400 rpm	7200 rpm and 5400 rpm
Operating temperature	5°C to 55°C (41°F to 131°F)		
*1 GB = 1 billion bytes when referring to hard drive storage capacity. Actual accessible capacity is less. Actual drive specifications may differ slightly.			
NOTE: Certain restrictions and exclusions apply. Contact technical support for details.			

DVD±RW and CD-RW Double-Layer Combo Drive specifications

Applicable disc	Read:	Write:
	CD-DA, CD+(E)G, CD-MIDI, CD-TEXT, CD-ROM, CD-ROM XA, MIXED MODE CD, CD-I, CD-I Bridge (Photo-CD, Video CD), Multisession CD (Photo-CD, CD-EXTRA, Portfolio, CD-R, CD-RW), CD-R, CD-RW, DVD-ROM (DVD-5, DVD-9, DVD-10, DVD-18), DVD-R, DVD-RW, DVD+R, DVD+RW, DVD-RAM	CD-R and CD-RW DVD+R, DVD+RW, DVD-R, DVD-RW, DVD-RAM
Access time	CD	DVD
Random	< 175 ms	< 230 ms
Cache buffer	2 MB	
Data transfer rate		
24X CD-ROM	3,600 KB/sec	
8X DVD-ROM	10,800 KB/sec	
24X CD-R	3,600 KB/sec	
16X CD-RW	2,400 KB/sec	
8X DVD+R	10,800 KB/sec	
4X DVD+RW	5,400 KB/sec	
8X DVD-R	10,800 KB/sec	
4X DVD-RW	5,400 KB/sec	
2.4X DVD+R(9)	2,700 KB/sec	
5X DVD-RAM	6,750 KB/sec	

DVD/CD-RW Combo Drive specifications

Applicable disc	Read:	Write:
	CD-DA, CD+(E)G, CD-MIDI, CD-TEXT, CD-ROM, CD-ROM XA, MIXED MODE CD, CD-I, CD-I Bridge (Photo-CD, Video CD), Multisession CD (Photo-CD, CD-EXTRA, Portfolio, CD-R, CD-RW), CD-R, CD-RW, DVD-ROM (DVD-5, DVD-9, DVD-10, DVD-18), DVD-R, DVD-RW, DVD+R, DVD+RW, DVD-RAM	CD-R and CD-RW
Access time	CD	DVD
Random	< 110 ms	< 130 ms
Cache buffer	2 MB	
Data transfer rate		
24X CD-ROM	3,600 KB/sec	
8X DVD	3,600 KB/sec	
24X CD-R	3,600 KB/sec	
24X CD-RW	3,600 KB/sec	

DVD-ROM Drive

Applicable disc	DVD-ROM (DVD-5, DVD-9, DVD-10, DVD-18, CD-ROM (Mode 1 and 2), CD Digital Audio, CD-XA ready (Mode 2, Form 1 and Form 2), CD-I (Mode 2, Form 1 and Form 2), CD-R, CD-RW, Photo CD (single and multisession), CD-Bridge)	
Access time	CD	DVD
Random	< 100 ms	< 125 ms
Cache buffer	512 KB	
Data transfer rate		
CD-R (24X)	3600 KB/s (150 KB/s at 1X CD rate)	
CD-RW (10X)	1500 KB/s (150 KB/s at 1X CD rate)	
CD-ROM (24X)	3600 KB/s (150 KB/s at 1X CD rate)	
DVD (8X)	10,800 KB/s (1,352 KB/s at 1X DVD rate)	
Multiword DMA mode 2	16.6 MB/s	

System DMA specifications

Hardware DMA	System function
DMA0	Not applicable
DMA1*	Not applicable
DMA2*	Not applicable
DMA3	Not applicable
DMA4	Direct memory access controller
DMA5*	Available for ExpressCard
DMA6	Not assigned
DMA7	Not assigned

*ExpressCard controller can use DMA 1, 2, or 5.

System interrupt specifications

Hardware IRQ	System function
IRQ0	System timer
IRQ1	Standard 101-/102-Key or Microsoft® Natural Keyboard
IRQ2	Cascaded
IRQ3	Intel 82801DB/DBM USB2 Enhanced Host Controller—24CD
IRQ4	COM1
IRQ5*	Conexant AC—Link Audio Intel 82801DB/DBM SMBus Controller—24C3 Data Fax Modem with SmartCP
IRQ6	Diskette drive
IRQ7*	Parallel port
IRQ8	System CMOS/real-time clock
IRQ9*	Microsoft ACPI-compliant system
IRQ10*	Intel USB UHCI controller—24C2 Intel 82852/82855 GM/GME Graphic Controller Realtek RTL8139 Family PCI Fast Ethernet Controller
IRQ11	Intel USB EHCI controller—24CD Intel USB UHCI controller—24C4 Intel USB UHCI controller—24C7 Intel Pro/Wireless 2200BG TI OHCI 1394 host controller TI PCI1410 CardBus controller
IRQ12	Synaptics PS/2 TouchPad
IRQ13	Numeric data processor
IRQ14	Primary IDE channel
IRQ15	Secondary IDE channel

*Default configuration; audio possible configurations are IRQ5, IRQ7, IRQ9, IRQ10, or none.

NOTE: ExpressCards may assert IRQ3, IRQ4, IRQ5, IRQ7, IRQ9, IRQ10, IRQ11, or IRQ15. Either the infrared or the serial port may assert IRQ3 or IRQ4.

System I/O address specifications

I/O address (hex)	System function (shipping configuration)
000 - 00F	DMA controller no. 1
010 - 01F	Unused
020 - 021	Interrupt controller no. 1
022 - 024	Opti chipset configuration registers
025 - 03F	Unused
02E - 02F	87334 "Super I/O" configuration for CPU
040 - 05F	Counter/timer registers
044 - 05F	Unused
060	Keyboard controller
061	Port B
062 - 063	Unused
064	Keyboard controller
065 - 06F	Unused
070 - 071	NMI enable/RTC
072 - 07F	Unused
080 - 08F	DMA page registers
090 - 091	Unused
092	Port A
093 - 09F	Unused
0A0 - 0A1	Interrupt controller no. 2
I/O Address (hex)	System Function (shipping configuration)
0A2 - 0BF	Unused
0C0 - 0DF	DMA controller no. 2
0E0 - 0EF	Unused
0F0 - 0F1	Coprocessor busy clear/reset
0F2 - 0FF	Unused
100 - 16F	Unused
170 - 177	Secondary fixed disk controller
178 - 1EF	Unused
1F0 - 1F7	Primary fixed disk controller
1F8 - 200	Unused
201	JoyStick (decoded in ESS1688)
202 - 21F	Unused

I/O address (hex)	System function (shipping configuration)
220 - 22F	Entertainment audio
230 - 26D	Unused
26E - 26	Unused
278 - 27F	Unused
280 - 2AB	Unused
2A0 - 2A7	Unused
2A8 - 2E7	Unused
2E8 - 2EF	Reserved serial port
2F0 - 2F7	Unused
2F8 - 2FF	Infrared port
300 - 31F	Unused
320 - 36F	Unused
370 - 377	Secondary diskette drive controller
378 - 37F	Parallel port (LPT1/default)
380 - 387	Unused
388 - 38B	FM synthesizer—OPL3
38C - 3AF	Unused
3B0 - 3BB	VGA
3BC - 3BF	Reserved (parallel port/no EPP support)
3C0 - 3DF	VGA
3E0 - 3E1	ExpressCard controller in CPU
3E2 - 3E3	Unused
3E8 - 3EF	Internal modem
3F0 - 3F7	"A" diskette controller
3F8 - 3FF	Serial port (COM1/default)
CF8 - CFB	PCI configuration index register (PCIDIVO-1)
CFC - CFF	PCI configuration data register (PCIDIVO-1)

System memory map specifications

Size	Memory address	System function
640 KB	00000000-0009FFFF	Base memory
128 KB	000A0000-000BFFFF	Video memory
48 KB	000C0000-000CBFFF	Video BIOS
160 KB	000C8000-000E7FFF	Unused
64 KB	000E8000-000FFFFF	System BIOS
15 MB	00100000-00FFFFFF	Extended memory
58 MB	04800000-07FFFFFF	Super extended memory
58 MB	04800000-07FFFFFF	Unused
2 MB	08000000-080FFFFF	Video memory (direct access)
4 GB	08200000-FFFFFF	Unused
64 KB	FFFF0000-FFFFFFFF	System BIOS

7 Screw listing

This section provides specification and reference information for the screws and screw locks used in the computer. All screws listed in this section are available in the Screw Kit, spare part number 486305-001.

Phillips PM2.0×5.0 captive screw

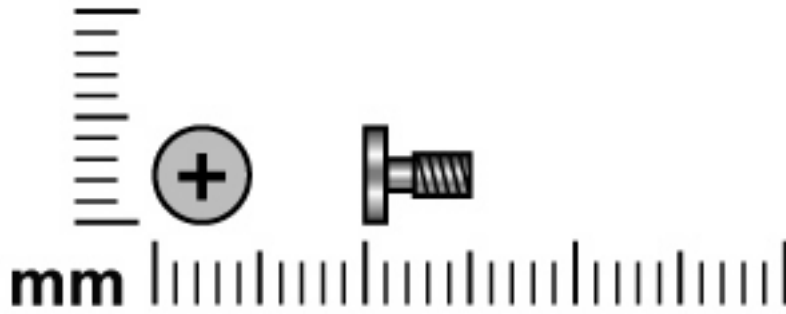

Color	Quantity	Length	Thread	Head diameter
Black	5	5.0 mm	2.0 mm	5.0 mm

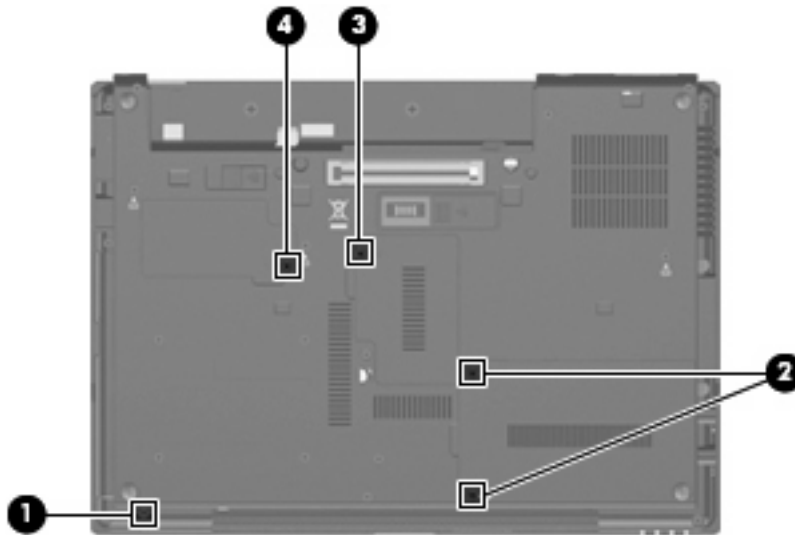

Where used:

- (1) One captive screw that secures the Bluetooth module compartment cover to the computer (screw is secured with a C-clip)
- (2) Two captive screws that secure the hard drive bay cover to the computer (screws are secured with C-clips)
- (3) One captive screw that secures the memory module compartment cover to the computer (screw is secured with a C-clip)
- (4) One captive screw that secures the WLAN module compartment cover to the computer (screw is secured with a C-clip)

Phillips PM2.5×11.0 captive screw

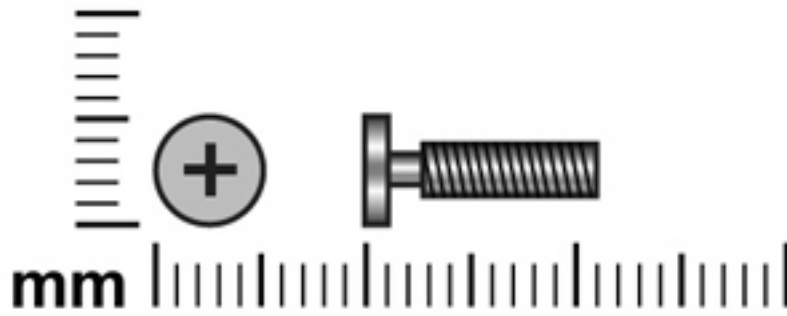

Color	Quantity	Length	Thread	Head diameter
Black	2	11.0 mm	2.5 mm	5.0 mm



Where used: One captive screw that secures the hard drive to the computer (screw is secured by a C-clip)

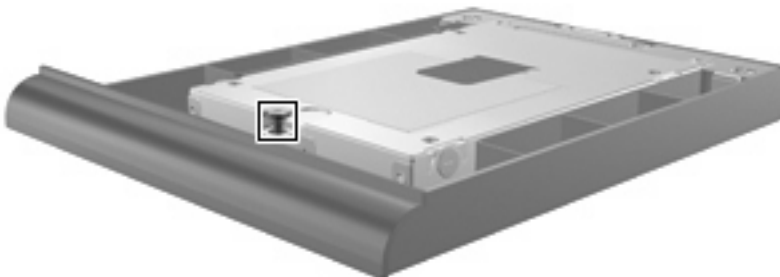

Where used: One captive screw that secures the hard drive to the upgrade bay cradle (screw is secured by a C-clip)

Phillips PM3.0×4.0 screw

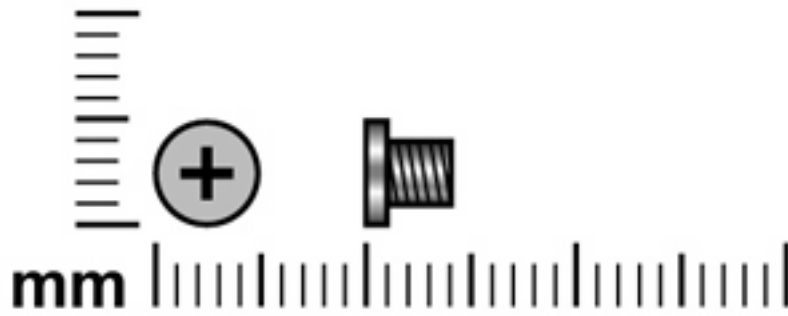

Color	Quantity	Length	Thread	Head diameter
Silver	4	4.0 mm	3.0 mm	5.0 mm

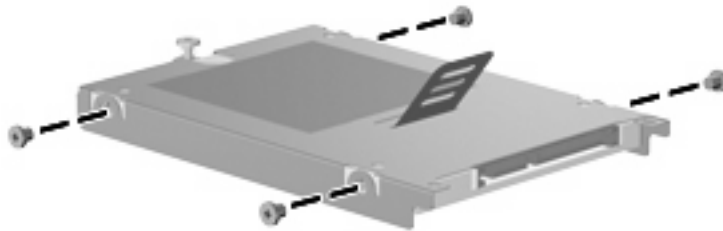

Where used: 4 screws that secure the hard drive bracket to the hard drive

Phillips 2.5×9.0 captive screw

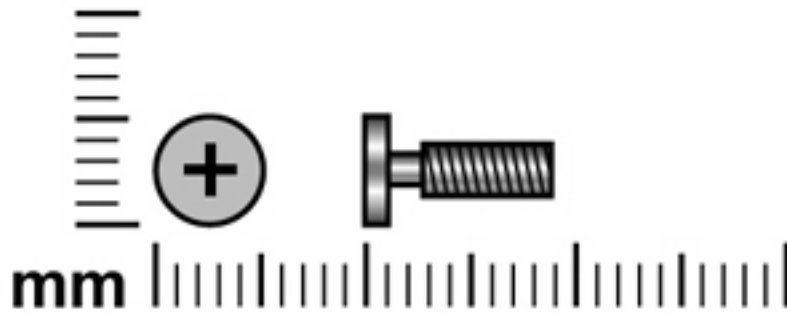

Color	Quantity	Length	Thread	Head diameter
Black	4	9.0 mm	2.5 mm	5.0 mm

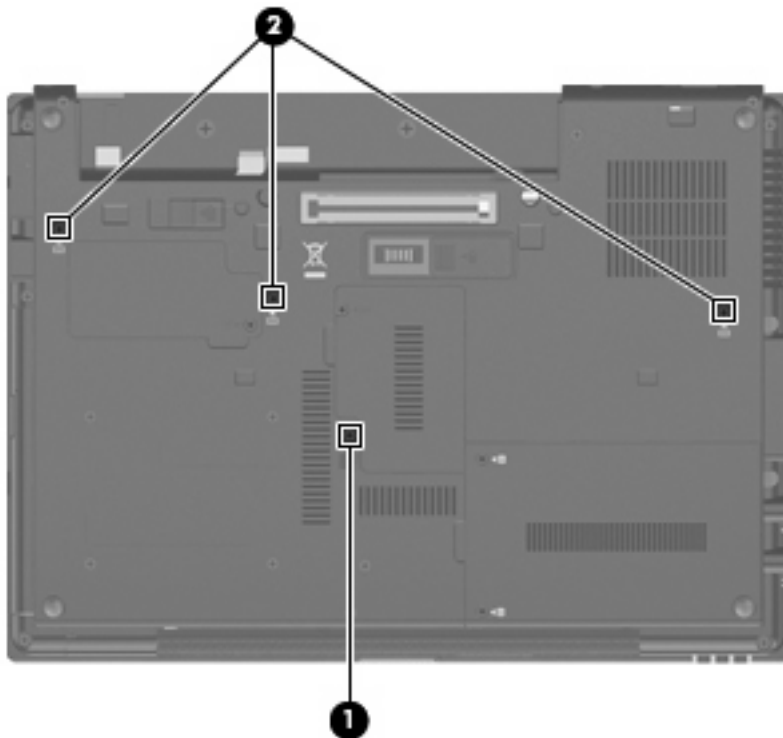

Where used:

- (1) One captive screw that secures the optical drive or upgrade bay device to the computer (screw is secured by a C-clip)
- (2) Three captive screws that secure the keyboard to the computer (screws are secured by C-clips)

Phillips PM2.0×3.0 screw

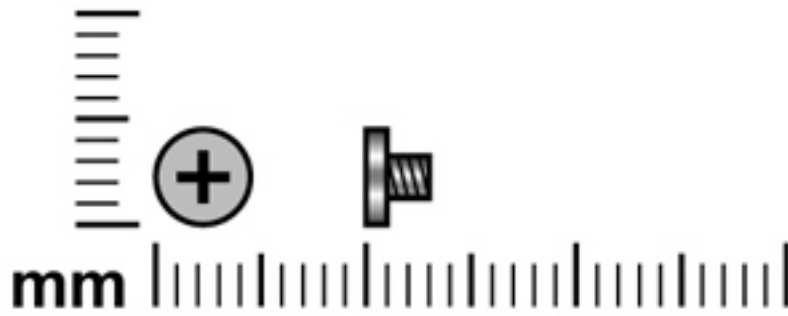

Color	Quantity	Length	Thread	Head diameter
Silver	2	3.0 mm	2.0 mm	4.5 mm

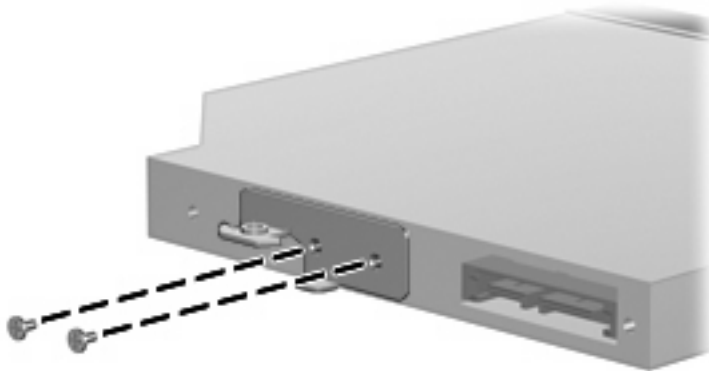

Where used: 2 screws that secure the optical drive bracket to the optical drive

Phillips PM2.5×4.0 screw

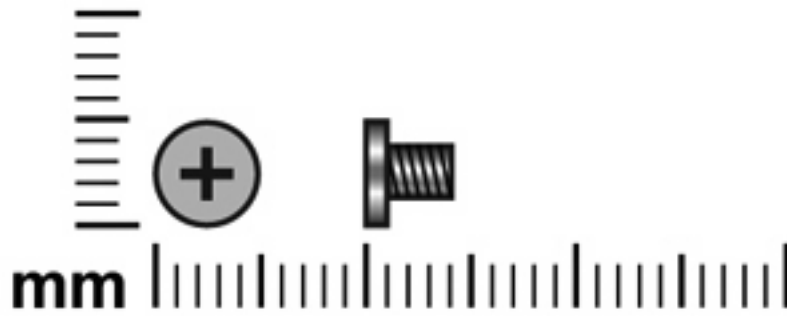

Color	Quantity	Length	Thread	Head diameter
Black	5	4.0 mm	2.5 mm	5.0 mm

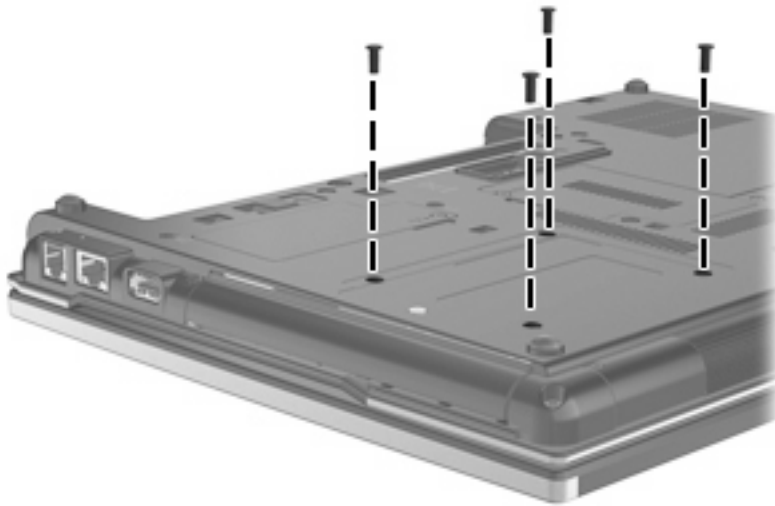

Where used: 4 screws that secure the upgrade bay device to the computer

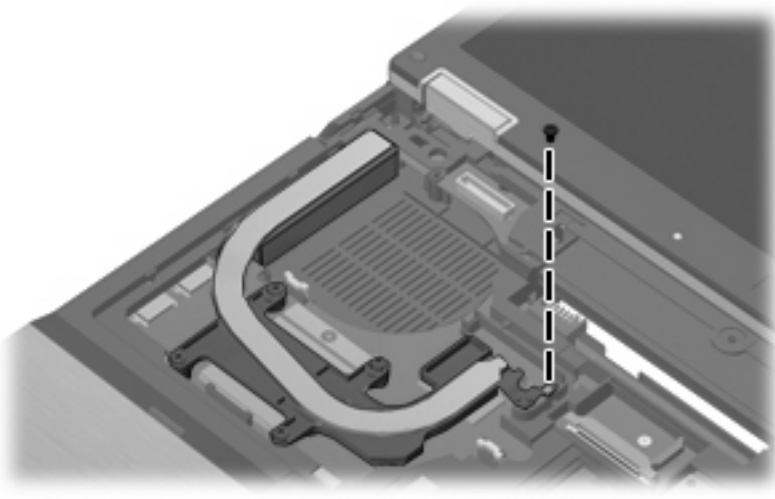

Where used: One screw that secures the heat sink to the system board on computer models equipped with discrete graphics subsystem memory

Phillips PM2.5×4.0 screw

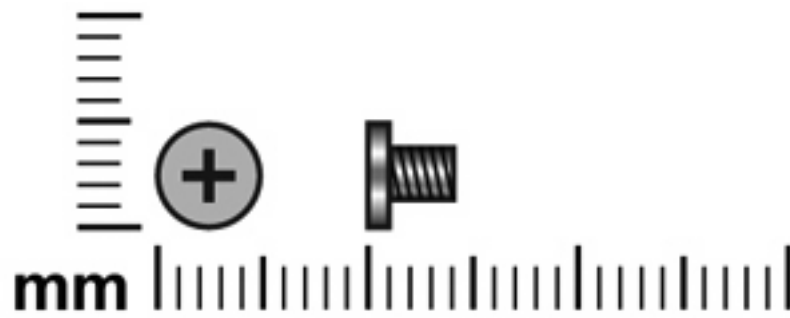

Color	Quantity	Length	Thread	Head diameter
Silver	19	4.0 mm	2.5 mm	5.0 mm

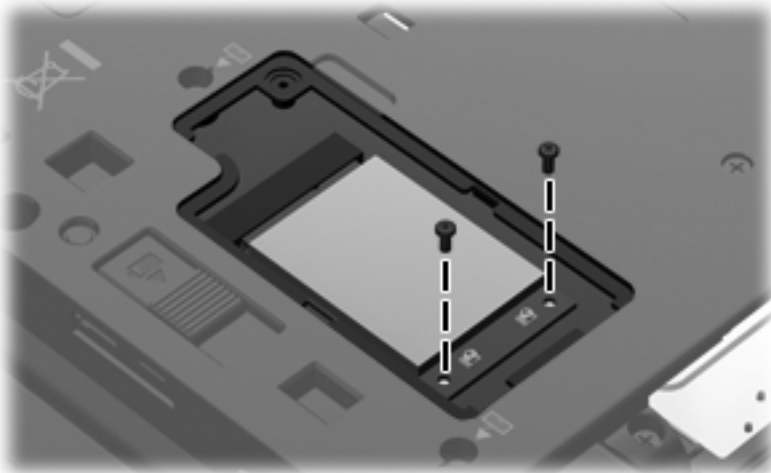

Where used: 2 screws that secure the WWAN module to the system board

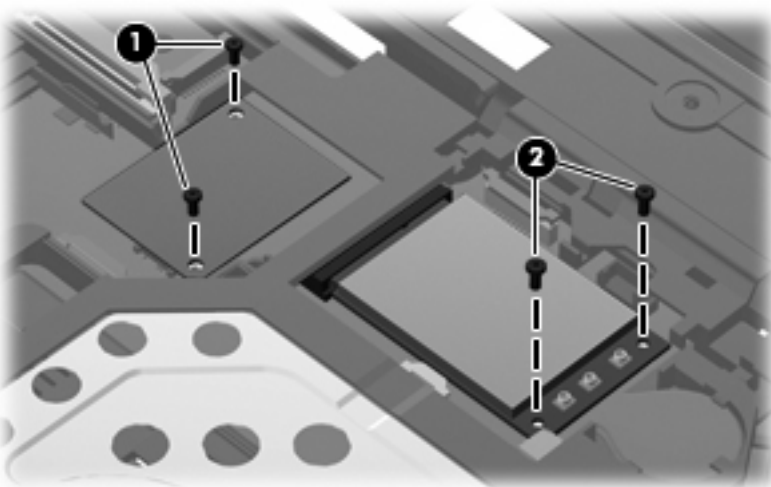

Where used:

(1) Two screws that secure the modem module to the system board

(2) Two screws that secure the WLAN module to the system board

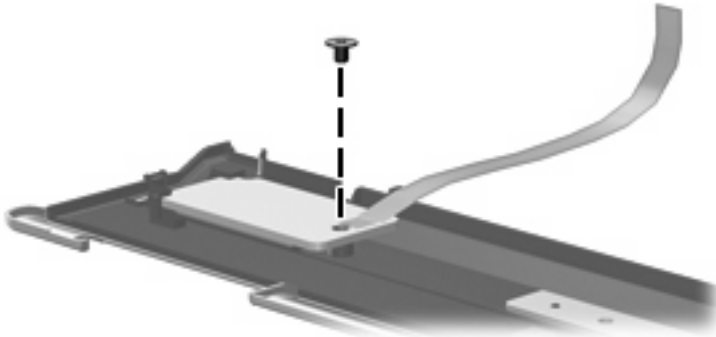

Where used: One screw that secures the power button board to the switch cover

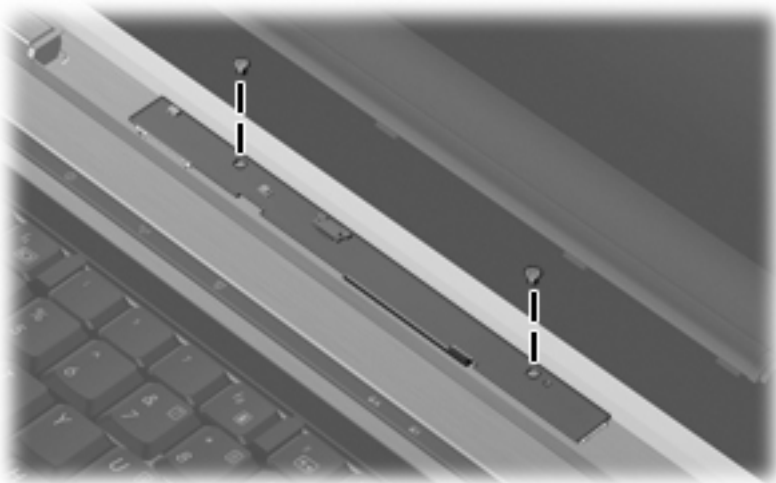

Where used: 2 screws that secure the display inverter to the display enclosure

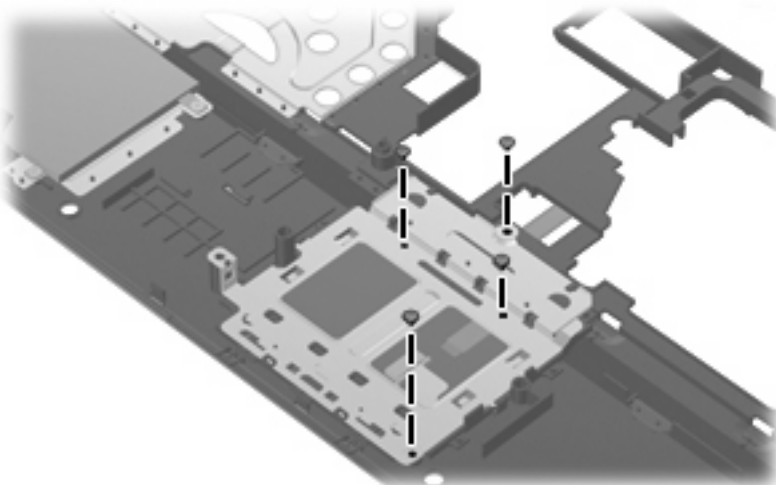

Where used: 4 screws that secure the TouchPad bracket to the top cover

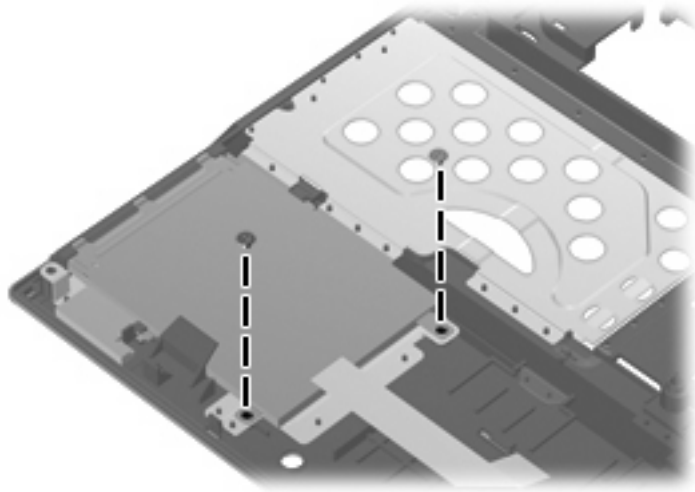

Where used: 2 screws that secure the audio/ExpressCard assembly to the top cover

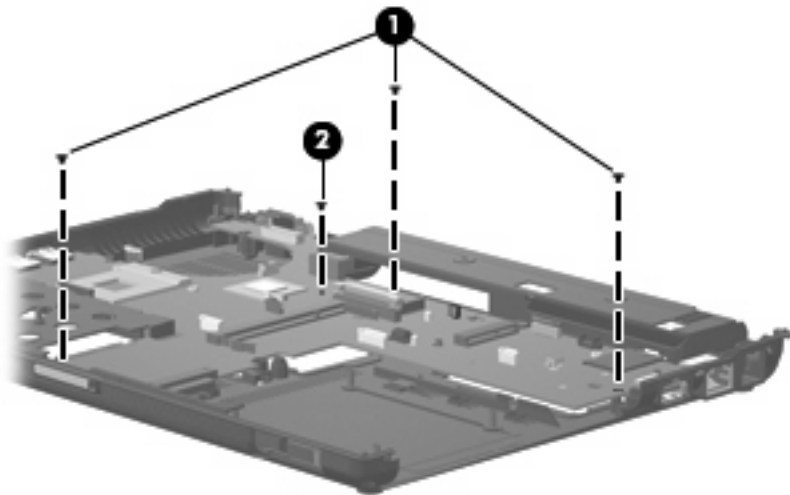

Where used:

(1) Three screws that secure the system board to the base enclosure on all computer models

(2) One screw that secures the system board to the base enclosure on computer models equipped with UMA graphics subsystem memory

Phillips PM2.0×3.0 broad-head screw

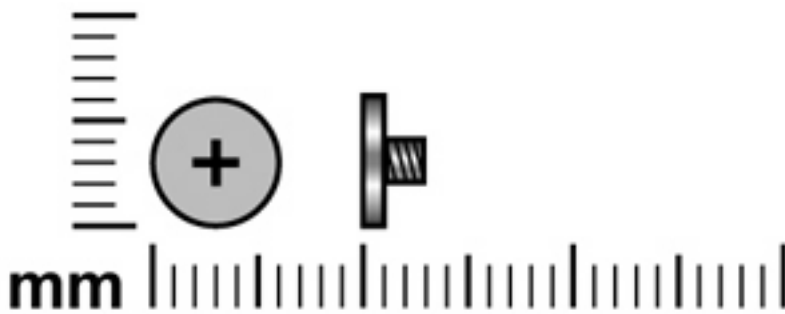

Color	Quantity	Length	Thread	Head diameter
Black	2	3.0 mm	2.0 mm	6.0 mm

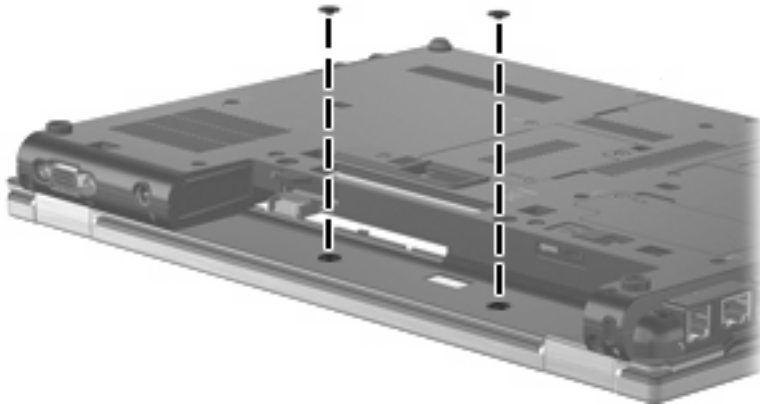

Where used: 2 screws that secure the switch cover to the computer

Torx8 T8M2.5×7.0 screw

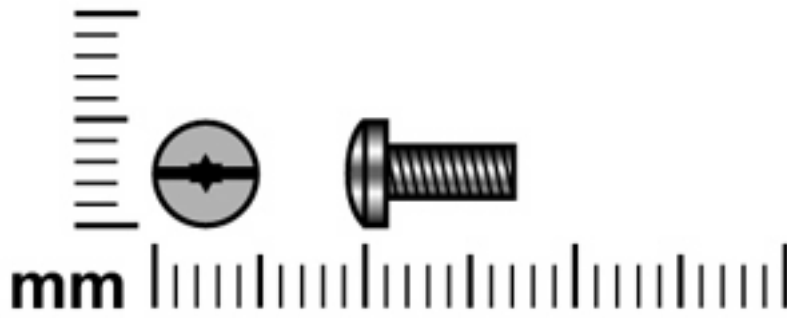

Color	Quantity	Length	Thread	Head diameter
Black	17	7.0 mm	2.5 mm	5.0 mm

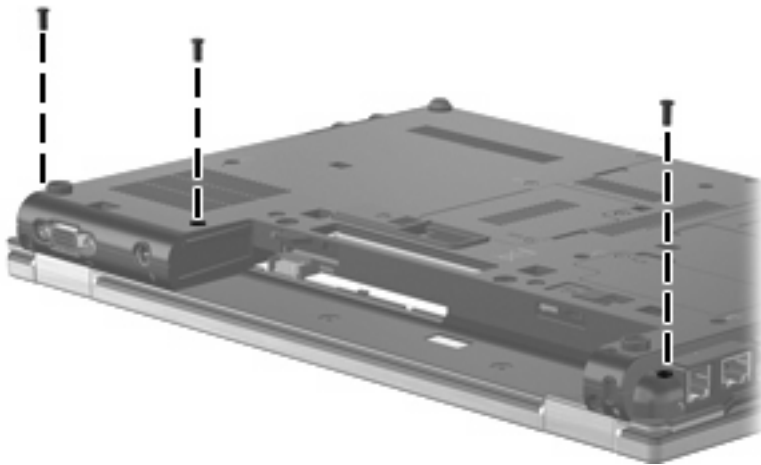

Where used: 3 screws that secure the switch cover to the computer

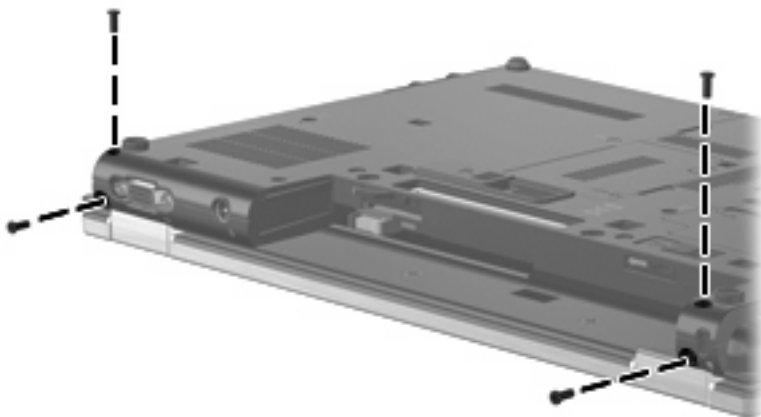

Where used: 4 screws that secure the display assembly to the computer



Where used: 2 screws that secure the display assembly to the computer

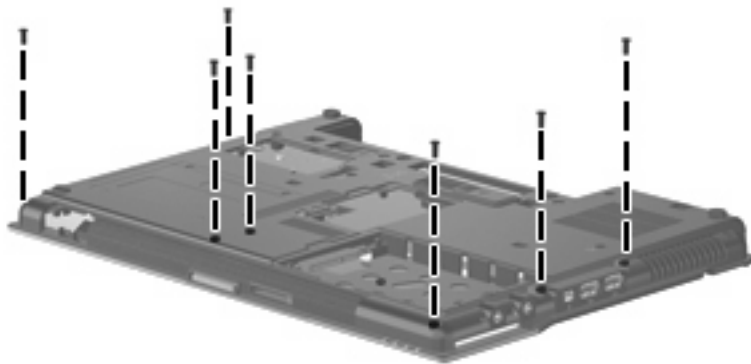

Where used: 7 screws that secure the top cover to the base enclosure

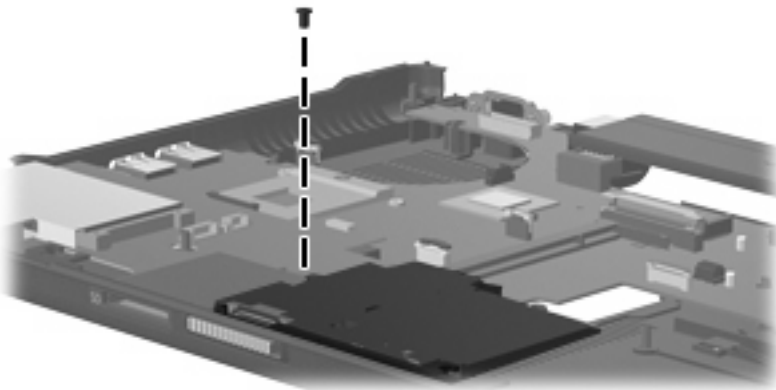

Where used: One screw that secures the speaker to the base enclosure

Phillips PM2.5×7.0 screw

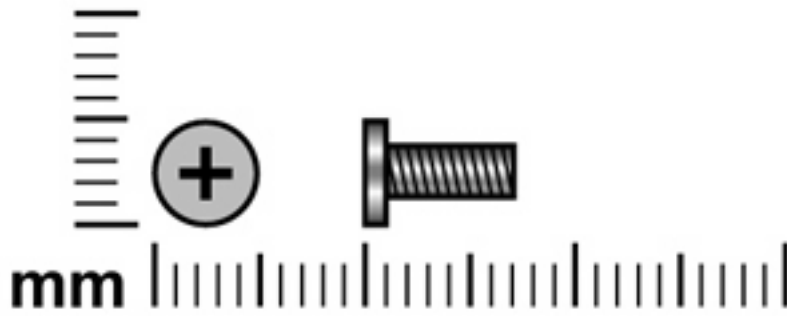

Color	Quantity	Length	Thread	Head diameter
Black	7	7.0 mm	2.5 mm	5.0 mm

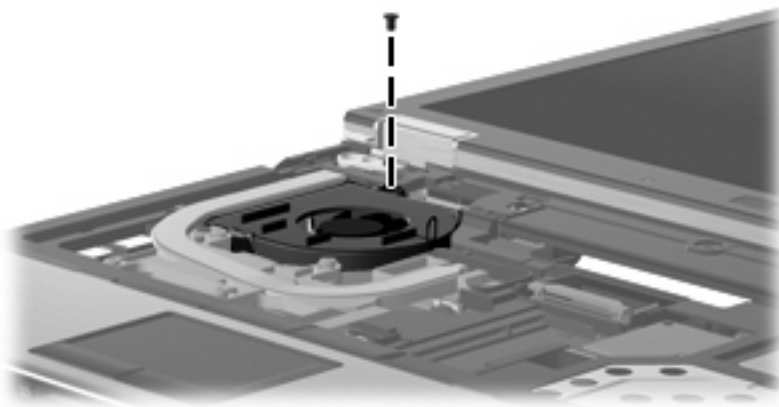

Where used: One screw that secures the fan to the base enclosure

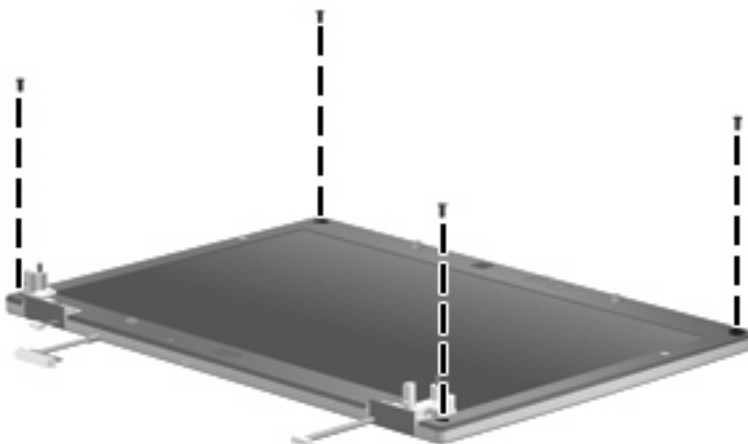

Where used: 4 screws that secure the display bezel to the display enclosure



Where used: 2 screws that secure the hinges to the display enclosure

Phillips PM2.5×11.0 captive screw

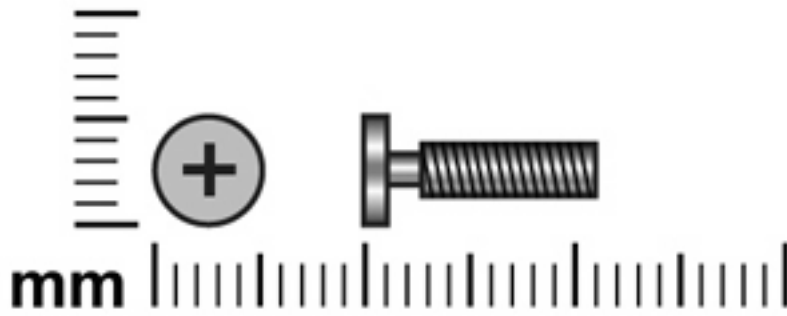

Color	Quantity	Length	Thread	Head diameter
Silver	4	11.0 mm	2.5 mm	5.0 mm

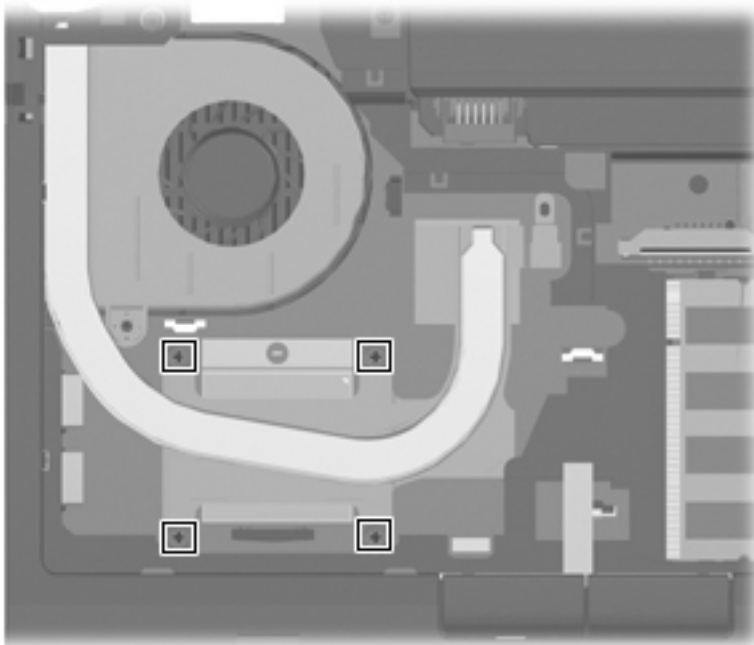

Where used: 4 captive screws that secure the heat sink to the system board (screws are secured by C-clips)

Phillips PM2.0×5.0 screw

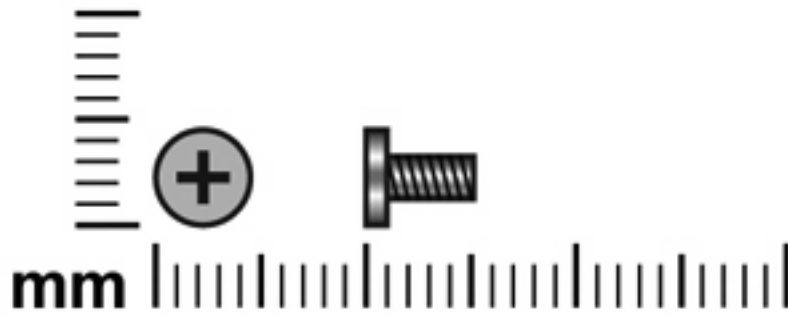

Color	Quantity	Length	Thread	Head diameter
Black	1	5.0 mm	2.0 mm	5.0 mm

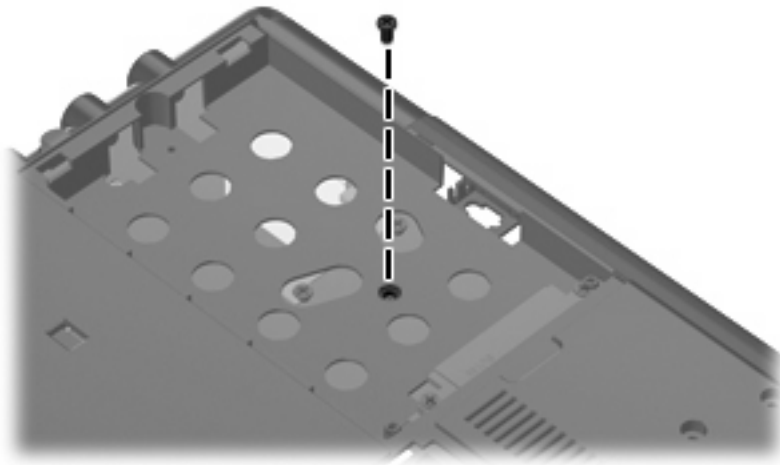

Where used: One screw that secures the top cover to the base enclosure

8 Backup and recovery in Windows Vista

This chapter describes features that are common to most models. Some features may not be available on your computer.

Overview

To protect your information, the computer provides tools to back up individual files and folders or your entire hard drive. In case of system instability or failure, you can use the backup files to restore the contents of your computer.

When creating backups, HP recommends the following sequence:

1. Create a set of recovery discs of the entire hard drive as soon as possible after you set up your computer.
2. Schedule periodic backups to record changes made to your computer.

In addition to manual backup-and-recovery tools, you can use Windows® System Recovery to automatically back up and restore your information. This feature automatically backs up changes made to your computer daily and also at important milestones, such as when you add a program or driver. Use this tool to restore the computer to a previous state without losing personal files or e-mails. You can also manually set restore points and change restore settings.

Creating recovery discs

After setting up the computer, create a set of recovery discs for the initial backup of the entire hard drive.

 **NOTE:** This process may take over an hour, depending on your computer speed and the amount of data being stored.

The recovery discs are used to start up (boot) the computer and recover the operating system and software to factory settings in case of system failure.

Note the following tips for creating recovery discs:

- Connect the computer to AC power during the process.
- Use any of the following types of discs (purchased separately): CD-R, CD-RW, DVD+R, DVD+R DL, DVD-R, DVD-R DL, or DVD±RW. The discs you use will depend on the type of optical drive installed in your computer.

 **NOTE:** DVDs and DVDs with double-layer (DL) support store more information than CDs and will reduce the number of recovery discs required.

- Number each disc before inserting it into the optical drive of the computer.

To create a set of recovery discs:

1. Select **Start > All Programs > Maintenance > Backup and Restore Center**.
2. Click **Back up computer**.
3. Follow the on-screen instructions.

 **NOTE:** Windows includes the User Account Control feature to improve the security of your computer. You may be prompted for your permission or password for tasks such as installing software, running utilities, or changing Windows settings. Refer to Help and Support for more information.

Backing up your information

After you create the recovery discs for the initial backup of the entire hard drive, you should schedule automatic backups of your files. You should also back up your files before you modify the hardware or software.

Several types of backup are available in the Backup and Restore Center:

- Individual files or folders
- Restore points
- Entire hard drive

Backup tips

- Connect the computer to AC power during the backup process.
- Store personal files in the Documents folder and back them up regularly.
- Back up templates that are stored in their associated programs.
- Save customized settings that appear in a window, toolbar, or menu bar by taking a screen shot of your settings. The screen shot can be a time-saver if you have to reset your preferences.

To create a screen shot:

1. Display the screen you want to save.
2. Copy the screen image:
To copy only the active window, press [alt+fn+prt sc](#).
To copy the entire screen, press [fn+prt sc](#).
3. Open a word-processing document, and then select **Edit > Paste**.
The screen image is added to the document.
4. Save the document.

Backing up individual files or folders

When you perform a backup of the entire hard drive, you are saving the full factory image, including the Windows operating system, software programs, all personal files and folders, and configuration settings.

You can back up a copy of the entire hard drive to either of the following locations:

- Optional external hard drive
- Optical discs (CDs or DVDs)

 **NOTE:** This process may take over an hour, depending on your computer speed and the amount of data being stored.

To back up your hard drive:

1. Select **Start > All Programs > Maintenance > Backup and Restore Center**.
2. Click **Back up computer**. You will be prompted to select a destination for the backup files.
3. Follow the on-screen instructions.

 **NOTE:** Windows includes the User Account Control feature to improve the security of your computer. You may be prompted for your permission or password for tasks such as installing software, running utilities, or changing Windows settings. Refer to Help and Support for more information.

Scheduling an automatic backup

You can schedule automatic backups for the entire system, for recovery points, or for specific files and folders. Backups can be scheduled at specific intervals (daily, weekly, or monthly).

To schedule an automatic backup:

1. Select **Start > All Programs > Maintenance > Backup and Restore Center**.
2. Click **Change settings**.

The Backup Status and Configuration Window opens.

3. Click **Change backup settings**. You will be prompted to select a destination for the backup files.
4. Follow the on-screen instructions.

 **NOTE:** Windows includes the User Account Control feature to improve the security of your computer. You may be prompted for your permission or password for tasks such as installing software, running utilities, or changing Windows settings. Refer to Help and Support for more information.

Creating system restore points

In addition to the manual backup-and-recovery tools, you can use Windows System Recovery to automatically back up and restore your information. This feature automatically creates restore points just before a significant change is made to your system, such as the installation of a program or driver. You can also set manual restore points.

 **NOTE:** The first system restore point is a snapshot of the entire image that is automatically created the first time you perform a backup. Subsequent recovery points make copies of changes made after that time.

HP recommends that you create manual restore points at the following times:

- Before you add or extensively modify software or hardware
- Periodically, whenever the system is performing optimally

 **NOTE:** Recovering to an earlier restore point does not delete data files or e-mails created since that restore point. To create a system restore point:

1. Select **Start > All Programs > Maintenance > Backup and Restore Center**.
2. On the left side of the screen, click **Create a restore point or change settings**.
3. Click **Create**. You will be prompted to name this restore point.
4. Follow the on-screen instructions.

 **NOTE:** Windows includes the User Account Control feature to improve the security of your computer. You may be prompted for your permission or password for tasks such as installing software, running utilities, or changing Windows settings. Refer to Help and Support for more information.

Performing a recovery

In case of hard drive failure or system instability, the computer provides tools to recover your files.

You can recover your information using the following methods:

 **NOTE:** Have your backup files available. Some of these methods will prompt you for your backup files stored on recovery discs or on a drive.

- Recovering individual files that you have previously backed up using Backup and Restore Center
- Restoring the computer to a previous state by using system restore points
- Recovering individual files that you have previously backed up or the entire hard drive using **f8** recovery tools:

 **NOTE:** You can use these methods only if the Windows recovery partition has not been deleted.

- Windows Recovery Environment (WinRE)
- Recovery Manager
- Recovering the entire hard drive using **f11**

 **NOTE:** You can use this method only if the Windows recovery partition has not been deleted.

- Recovering information using an operating system DVD (purchased separately)

Recovering individual files

To recover individual files using the Backup and Restore Center, follow these steps:

1. If possible, back up all personal files.
2. Select **Start > All Programs > Maintenance > Backup and Restore Center**.
3. Click **Restore files**. You will be prompted to select the location of the backup files.
4. Follow the on-screen instructions.

 **NOTE:** Windows includes the User Account Control feature to improve the security of your computer. You may be prompted for your permission or password for tasks such as installing software, running utilities, or changing Windows settings. Refer to Help and Support for more information.

Restoring the computer to a previous state

Your computer automatically creates restore points daily (depending on your computer activity) and when you make a major change to the computer, such as adding software or a new driver. If you decide to reverse changes made to the computer, you can revert back to a previous restore point.

 **NOTE:** If you don't like the state of your computer after you restore it, you can also undo the restoration.

To access a restore point:

1. Select **Start > All Programs > Maintenance > Backup and Restore Center**.
2. Click **Restore my computer to an earlier time**. A calendar is displayed to help you find dates associated with your restore points.
3. Select the restore point to revert to.

 **NOTE:** If you do not use your computer every day, some days may not have restore points.

Recovering information using f8 recovery tools

You can recover individual files or the entire hard drive using the recovery discs that you previously created or an optional external hard drive where you have backed up your information.

The following tools will help you recover your information:

- Windows Recovery Environment (WinRE)
- Recovery Manager

 **NOTE:** You can use these recovery methods only if the Windows recovery partition has not been deleted.

Recovering information using Windows Recovery Environment (WinRE)

Windows Recovery Environment (WinRE) can perform a recovery from either an optional external hard drive where you have backed up your information or from recovery discs that you previously created.

- △ **CAUTION:** Using Windows Recovery Environment (WinRE) will completely erase hard drive contents and reformat the hard drive. All files you have created and any software installed on the computer will be permanently removed. When reformatting is complete, the recovery process will restore the operating system, as well as the drivers, software, and utilities from the backup used for recovery.

To initiate recovery using WinRE, follow these steps:

-  **NOTE:** This process will take several minutes.

1. If possible, back up all personal files.
2. Restart the computer, and then press **F8** before the Windows operating system loads.
3. Select **Repair your computer**.

-  **NOTE:** The “Repair your computer” option is displayed only if the Windows recovery partition has not been deleted. If the option is not displayed, refer to the “Recovering information using a Windows Vista operating system DVD (purchased separately)” section.

4. Follow the on-screen instructions.
5. Click **Next**.
6. Select your user name, type your password (if applicable), and then click **OK**.
7. If you are using recovery discs, insert the last disc of the recovery disc backup set.

-  **NOTE:** Inserting the last disc of the backup set confirms the presence of a valid backup. If you insert any other disc, the backup will not be recognized.

– or –

If you are using an optional external hard drive, connect it to the computer.

8. Click **Windows Complete PC Restore**.
9. Follow the on-screen instructions.

Recovering information using Recovery Manager

If other methods do not work, you can recover your hard drive (in its factory state) as a last resort:

- △ **CAUTION:** Using Recovery Manager will completely erase hard drive contents and reformat the hard drive. All files you have created and any software installed on the computer will be permanently removed. Recovery Manager reinstalls the operating system and HP programs and drivers that were installed at the factory. Software not installed at the factory must be reinstalled.

1. If possible, back up all personal files.
2. Restart the computer, and then press **f8** before the Windows operating system loads.
3. Select **Repair your computer**.

 **NOTE:** The “Repair your computer” option is displayed only if the Windows recovery partition has not been deleted. If the option is not displayed, refer to the “Recovering information using a Windows Vista operating system DVD (purchased separately)” section.

4. Follow the on-screen instructions.
5. Click **Next**.
6. Select your user name, type your password (if applicable), and then click **OK**.
7. Click **HP Recovery Manager**.
8. Follow the on-screen instructions.

Recovering the entire hard drive using f11

You can recover the entire hard drive (in its factory state) from the Windows recovery partition using **f11**.

- △ **CAUTION:** Using **f11** will completely erase hard drive contents and reformat the hard drive. All files you have created and any software installed on the computer will be permanently removed. The **f11** recovery tool reinstalls the operating system and HP programs and drivers that were installed at the factory. Software not installed at the factory must be reinstalled.

 **NOTE:** You can use this recovery method only if the Windows recovery partition has not been deleted. To recover the hard drive from the recovery partition, follow these steps:

1. If possible, back up all personal files.
2. Turn on or restart the computer, and then press **esc** while the “Press the ESC key for Startup Menu” message is displayed at the bottom of the screen.
3. Press **f11** while the “Press for recovery” message is displayed on the screen.
4. Follow the on-screen instructions.

Recovering information using a Windows Vista operating system DVD (purchased separately)

You can purchase a Windows Vista® operating system DVD to reboot the computer and repair the operating system. During the restore process, you will be prompted for your entire drive backup files. Make sure that your most recent backup of the hard drive (stored on recovery discs or on an external drive) is easily accessible. To order a Windows Vista operating system DVD, go to <http://www.hp.com/support>, select your country or region, and follow the on-screen instructions. You can also order the DVD by calling technical support. For contact information, refer to the Worldwide Telephone Numbers booklet included with the computer.

-
- △ **CAUTION:** Using a Windows Vista operating system DVD will completely erase hard drive contents and reformat the hard drive. All files you have created and any software installed on the computer will be permanently removed. When reformatting is complete, the recovery process will help you restore the operating system, as well as drivers, software, and utilities.
-

To initiate recovery using a Windows Vista operating system DVD, follow these steps:

-
-  **NOTE:** This process will take several minutes.
-

1. If possible, back up all personal files.
2. Restart the computer, and then insert the Windows Vista operating system DVD into the optical drive before the Windows operating system loads.
3. When prompted, press any keyboard key.
4. Follow the on-screen instructions.
5. Click **Next**.
6. Select **Repair your computer**.
7. Follow the on-screen instructions.
8. Remove the Windows Vista operating system DVD.
9. If you are using recovery discs, insert the last disc of the recovery disc backup set.

-
-  **NOTE:** Inserting the last disc of the backup set confirms the presence of a valid backup. If you insert any other disc, the backup will not be recognized.
-

– or –

If you are using an optional external hard drive, connect it to the computer.

10. Click **Windows Complete PC Restore**.
11. Follow the on-screen instructions.

9 Backup and recovery in Windows XP

This chapter describes features that are common to most models. Some features may not be available on your computer.

Backing up your information

 **NOTE:** You can recover only the files that you have previously backed up. HP recommends that you use the Windows backup utility to create a hard drive backup as soon as you set up your computer.

With the Windows backup utility, you can perform the following tasks:

- Backing up your information regularly to protect your important system files
- Creating system recovery points that allow you to reverse undesirable changes to your computer by restoring the computer to an earlier state
- Scheduling backups at specific intervals or events

 **NOTE:** The Windows backup utility backs up only data files. The operating system, drivers, and programs are located on the operating system disc and System Recovery disc that are included with the computer.

When to back up

- On a regularly scheduled basis

 **NOTE:** Set reminders to back up your information periodically.

- Before the computer is repaired or restored
- Before you add or modify hardware or software

Backup suggestions

- Connect the computer to external power before performing backup and recovery procedures.
- Create system recovery points.
- Store personal files in the My Documents folder and back up these folders periodically.
- Back up templates stored in their associated programs.
- Save customized settings that appear in a window, toolbar, or menu bar by taking a screen shot of your settings. The screen shot can be a time saver if you have to reset your preferences.

To copy the screen and paste it into a word-processing document:

1. Display the screen you want to save.
2. Copy the screen image:
To copy only the active window, press **alt+fn+prt sc**.
To copy the entire screen, press **fn+prt sc**.
3. Open a word-processing document, click **Edit > Paste**.
The screen image is added to the document.
4. Save the document.

Backing up individual files or folders

You can back up individual files or folders to an optional external hard drive or to a network drive.

 **NOTE:** This process will take several minutes, depending on the file size and the speed of the computer.

To back up individual files or folders:

1. Select **Start > All Programs > Accessories > System Tools > Backup**.
The Backup or Restore Wizard page opens.
2. Click **Next**.
3. Click **Backup files and settings**, and then click **Next**.
4. Follow the on-screen instructions.

Backing up all files and folders

When you back up all files and folders, you are saving all personal files and folders, all system files, and configuration settings at one time.

 **NOTE:** When you back up all files and folders, this does not include the operating system or programs.

NOTE: This process may take over an hour, depending on your computer speed and the amount of data being stored.

NOTE: A copy of the backup files can be stored on an optional external hard drive or on a network drive.

To back up all files and folders:

1. Select **Start > All Programs > Accessories > System Tools > Backup**.
The Backup or Restore Wizard page opens.
2. Click **Next**.
3. Click **Backup files and settings**, and then click **Next**.
4. Click **All information on this computer**, and then click **Next**.
5. Follow the on-screen instructions.

Creating recovery points

When you back up system modifications since your last backup, you are creating system recovery points. This allows you to save a snapshot of your hard drive at a specific point in time. You can then recover back to that point if you want to reverse subsequent changes made to your system.

 **NOTE:** The first system recovery point, a snapshot of the entire image, is automatically created the first time you perform a backup. Subsequent recovery points make copies of changes made after that time.

HP recommends that you create recovery points at the following times:

- Before you add or extensively modify software or hardware
- Periodically, whenever the system is performing optimally

 **NOTE:** Recovering to an earlier recovery point does not affect data files or e-mails created since that recovery point.

To create a system recovery point:

1. Select **Start > All Programs > Accessories > System Tools > System Restore**.
The System Restore window opens.
2. Click **Create a new restore point**, and then click **Next**.
3. Type a short description of the restore point. This will be used as the name of the restore point.
4. Click **Create**.
5. Follow the on-screen instructions.

Scheduling backups

You can schedule backups for the entire system, for recovery points, or for specific files and folders. Backups can be scheduled at specific intervals (daily, weekly, or monthly) or at specific events, such as at system restart or when you log on.

To schedule backups:

1. Select **Start > All Programs > Accessories > System Tools > Schedule Tasks**.

The Schedule Tasks window opens.

2. Double-click **Add Scheduled Task**, and then click **Next**.
3. Select **Backup** in the Application list, and then click **Next**.
4. Type a name for the backup, select when you want the backup to be performed, and then click **Next**.
5. Enter your user name, password, and password again to confirm. Click **Next**, and then click **Finish**.

Performing a recovery

The Windows backup utility helps you recover important files that you have previously backed up in case of system failure.

 **NOTE:** To recover the operating system and programs, use the operating system disc and System Restore disc that are included with the computer.

Initiating a recovery in Windows

To initiate a recovery in Windows, follow these steps:

1. If possible, back up all personal files.
2. Select **Start > All Programs > Accessories > System Tools > Backup**.
The Backup or Restore Wizard page opens.
3. Click **Restore files and settings**, and then click **Next**.
4. Follow the on-screen instructions.

10 Connector pin assignments

1394

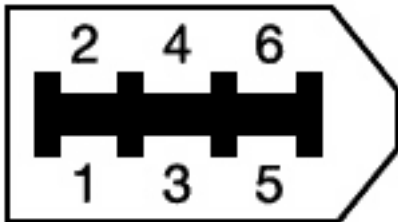

Pin	Assignment
1	Power
2	Ground
3	TPB-
4	TPB+
5	TPA-
6	TPA+

Audio-in (microphone)

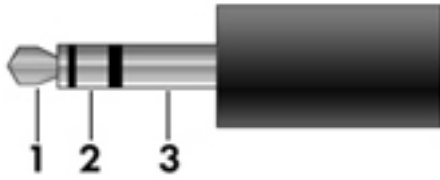

Pin	Signal
1	Audio signal in
2	Audio signal in
3	Ground

Audio-out (headphone)

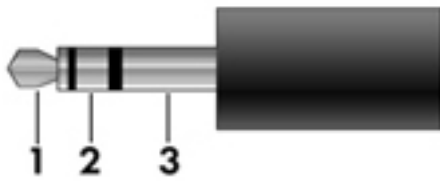

Pin	Signal
1	Audio out, left channel
2	Audio out, right channel
3	Ground

External monitor

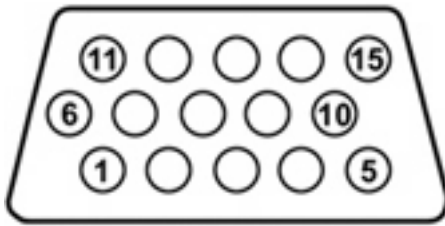

Pin	Signal
1	Red analog
2	Green analog
3	Blue analog
4	Not connected
5	Ground
6	Ground analog
7	Ground analog
8	Ground analog
9	+5 VDC
10	Ground
11	Monitor detect
12	DDC 2B data
13	Horizontal sync
14	Vertical sync
15	DDC 2B clock

RJ-11 (modem)

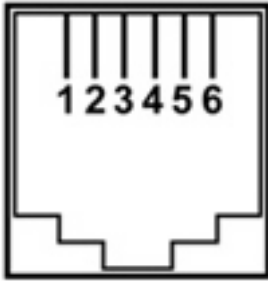

Pin	Signal
1	Unused
2	Tip
3	Ring
4	Unused
5	Unused
6	Unused

RJ-45 (network)

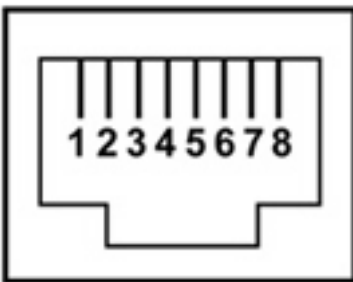

Pin	Signal
1	Transmit +
2	Transmit -
3	Receive +
4	Unused
5	Unused
6	Receive -
7	Unused
8	Unused

Universal Serial Bus

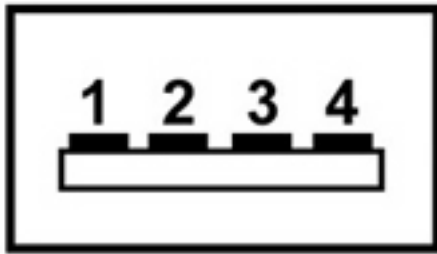

Pin	Signal
1	+5 VDC
2	Data -
3	Data +
4	Ground

11 Power cord set requirements

The wide range input feature of the computer permits it to operate from any line voltage from 100 to 120 volts AC or from 220 to 240 volts AC.

The 3-conductor power cord set included with the computer meets the requirements for use in the country or region where the equipment is purchased.

Power cord sets for use in other countries and regions must meet the requirements of the country or region where the computer is used.

Requirements for all countries and regions

The requirements listed below are applicable to all countries and regions:

- The length of the power cord set must be at least 1.5 m (5.0 ft) and no more than 2.0 m (6.5 ft).
- All power cord sets must be approved by an acceptable accredited agency responsible for evaluation in the country or region where the power cord set will be used.
- The power cord sets must have a minimum current capacity of 10 amps and a nominal voltage rating of 125 or 250 V AC, as required by the power system of each country or region.
- The appliance coupler must meet the mechanical configuration of an EN 60 320/IEC 320 Standard Sheet C13 connector for mating with the appliance inlet on the back of the computer.

Requirements for specific countries and regions

Country/region	Accredited agency	Applicable note number
Australia	EANSW	1
Austria	OVE	1
Belgium	CEBC	1
Canada	CSA	2
Denmark	DEMKO	1
Finland	FIMKO	1
France	UTE	1
Germany	VDE	1
Italy	IMQ	1
Japan	METI	3
The Netherlands	KEMA	1
Norway	NEMKO	1
The People's Republic of China	CCC	5
South Korea	EK	4
Sweden	SEMKO	1
Switzerland	SEV	1
Taiwan	BSMI	4
The United Kingdom	BSI	1
The United States	UL	2

1. The flexible cord must be Type HO5VV-F, 3-conductor, 1.0-mm² conductor size. Power cord set fittings (appliance coupler and wall plug) must bear the certification mark of the agency responsible for evaluation in the country or region where it will be used.
2. The flexible cord must be Type SPT-3 or equivalent, No. 18 AWG, 3-conductor. The wall plug must be a two-pole grounding type with a NEMA 5-15P (15 A, 125 V) or NEMA 6-15P (15 A, 250 V) configuration.
3. The appliance coupler, flexible cord, and wall plug must bear a "T" mark and registration number in accordance with the Japanese Dentori Law. The flexible cord must be Type VCT or VCTF, 3-conductor, 1.00-mm² conductor size. The wall plug must be a two-pole grounding type with a Japanese Industrial Standard C8303 (7 A, 125 V) configuration.
4. The flexible cord must be Type RVV, 3-conductor, 0.75-mm² conductor size. Power cord set fittings (appliance coupler and wall plug) must bear the certification mark of the agency responsible for evaluation in the country or region where it will be used.
5. The flexible cord must be Type VCTF, 3-conductor, 0.75-mm² conductor size. Power cord set fittings (appliance coupler and wall plug) must bear the certification mark of the agency responsible for evaluation in the country or region where it will be used.

12 Recycling

Battery

When a battery has reached the end of its useful life, do not dispose of the battery in general household waste. Follow the local laws and regulations in your area for computer battery disposal.

Display

- ⚠ **WARNING!** The backlight contains mercury. Exercise caution when removing and handling the backlight to avoid damaging this component and causing exposure to the mercury.
- ⚠ **CAUTION:** The procedures in this appendix can result in damage to display components. The only components intended for recycling purposes are the liquid crystal display (LCD) panel and the backlight. When you remove these components, handle them carefully.
- 📄 **NOTE: Materials Disposal.** This HP product contains mercury in the backlight in the display assembly that might require special handling at end-of-life. Disposal of mercury may be regulated because of environmental considerations. For disposal or recycling information, contact your local authorities, or see the Electronic Industries Alliance (EIA) Web site at <http://www.eiae.org>.

This section provides disassembly instructions for the display assembly. The display assembly must be disassembled to gain access to the backlight **(1)** and the liquid crystal display (LCD) panel **(2)**.



- 📄 **NOTE:** The procedures provided in this appendix are general disassembly instructions. Specific details, such as screw sizes, quantities, and locations, and component shapes and sizes, can vary from one computer model to another.

Perform the following steps to disassemble the display assembly:

1. Remove all screw covers (1) and screws (2) that secure the display bezel to the display assembly.

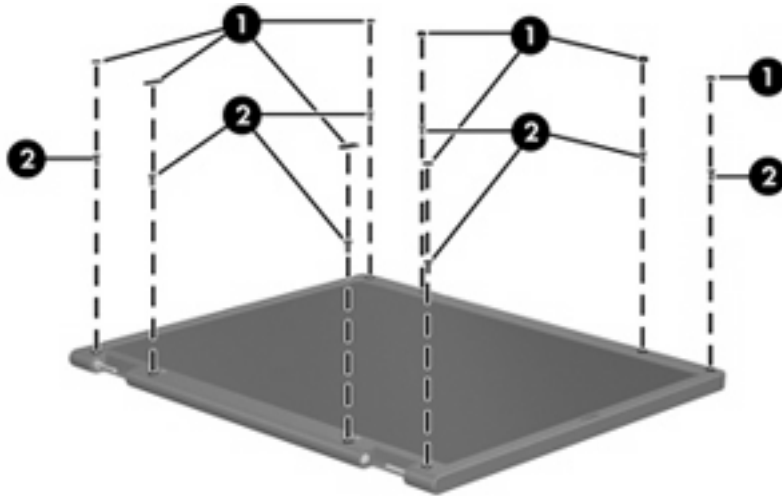

2. Lift up and out on the left and right inside edges (1) and the top and bottom inside edges (2) of the display bezel until the bezel disengages from the display assembly.

3. Remove the display bezel (3).

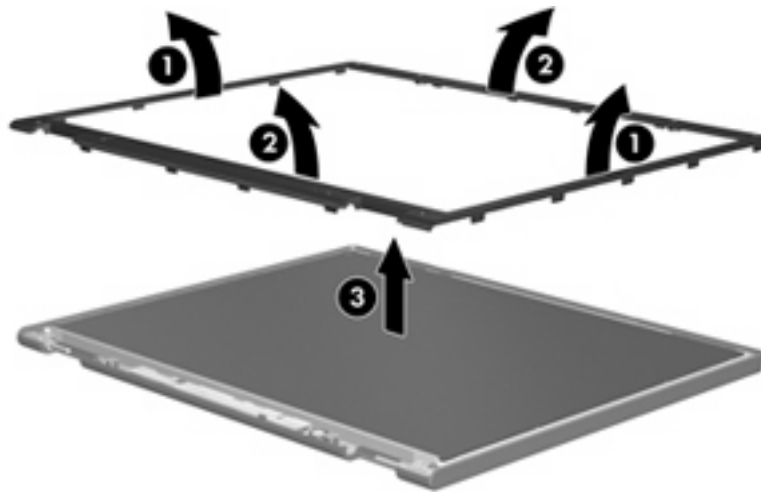

4. Disconnect all display panel cables (1) from the display inverter and remove the display inverter (2).

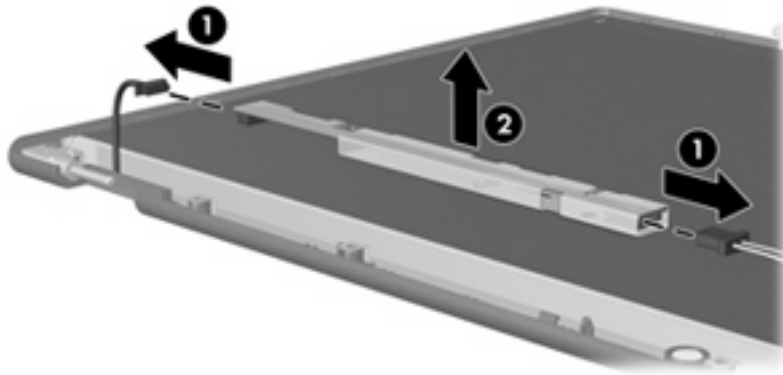

5. Remove all screws (1) that secure the display panel assembly to the display enclosure.
6. Remove the display panel assembly (2) from the display enclosure.

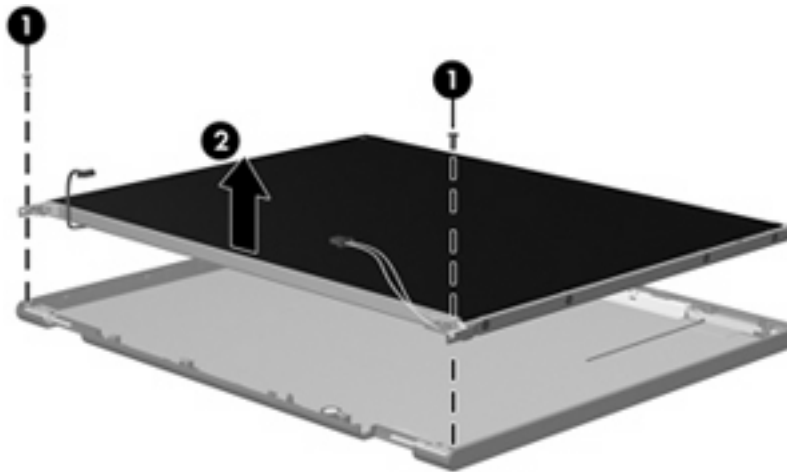

7. Turn the display panel assembly upside down.
8. Remove all screws that secure the display panel frame to the display panel.

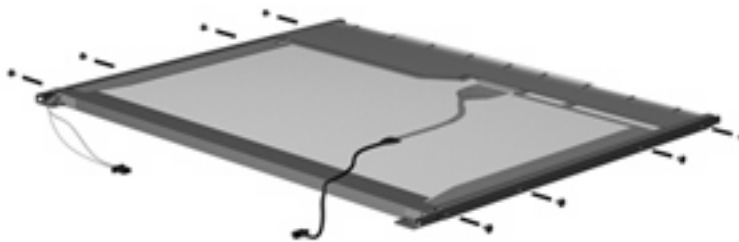

9. Use a sharp-edged tool to cut the tape (1) that secures the sides of the display panel to the display panel frame.

10. Remove the display panel frame (2) from the display panel.

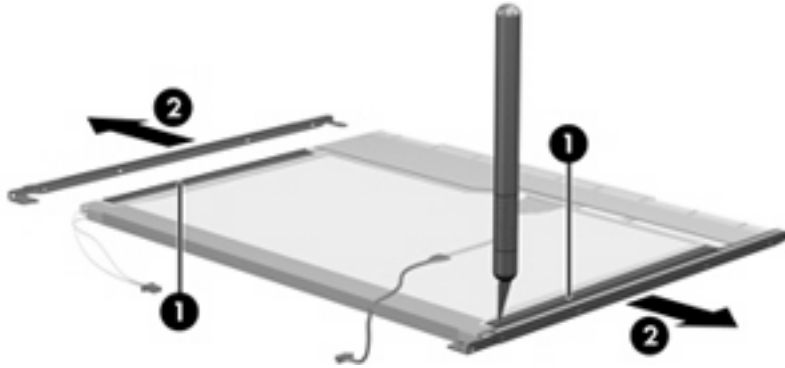

11. Remove the screws (1) that secure the backlight cover to the display panel.
12. Lift the top edge of the backlight cover (2) and swing it outward.

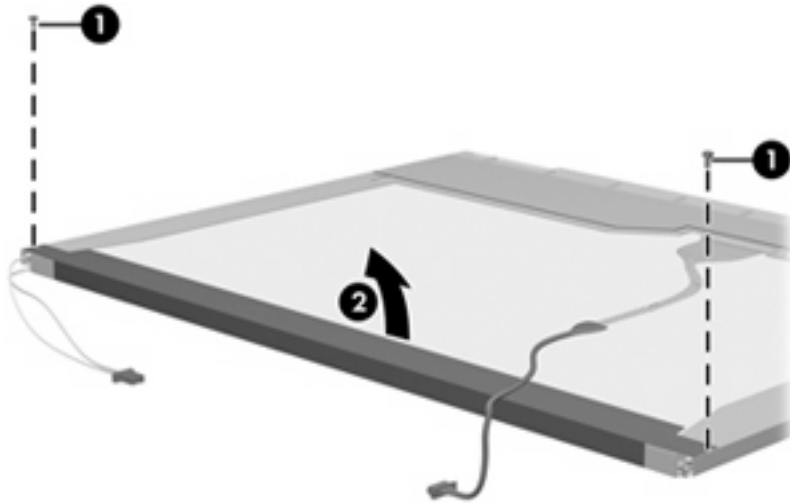

13. Remove the backlight cover.
14. Turn the display panel right-side up.

15. Remove the backlight cables (1) from the clip (2) in the display panel.

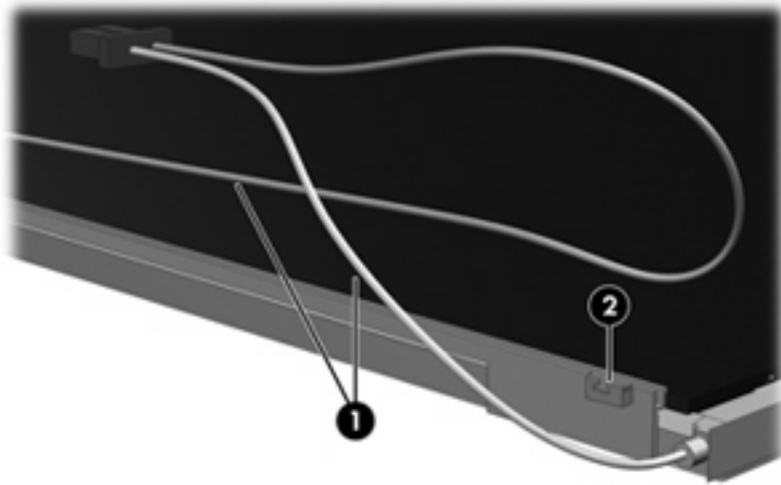

16. Turn the display panel upside down.

⚠ WARNING! The backlight contains mercury. Exercise caution when removing and handling the backlight to avoid damaging this component and causing exposure to the mercury.

17. Remove the backlight frame from the display panel.

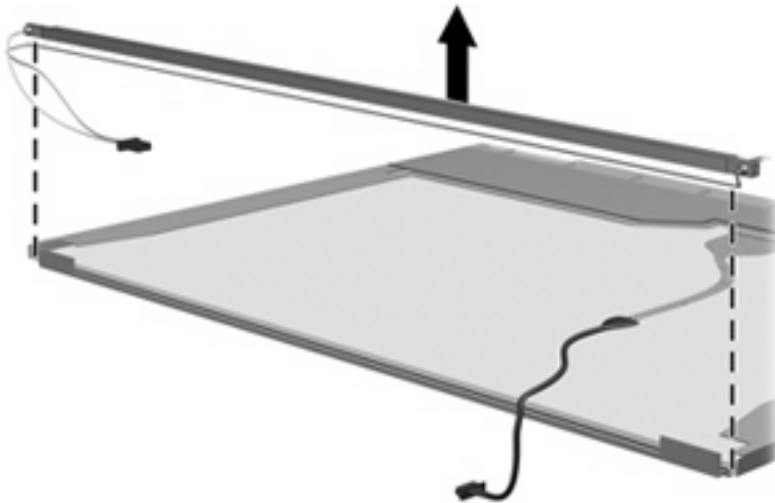

18. Remove the backlight from the backlight frame.

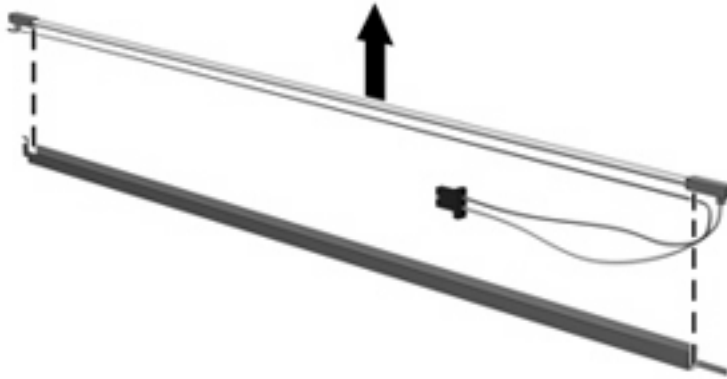

19. Disconnect the display panel cable (1) from the LCD panel.
20. Remove the screws (2) that secure the LCD panel to the display rear panel.
21. Release the LCD panel (3) from the display rear panel.
22. Release the tape (4) that secures the LCD panel to the display rear panel.

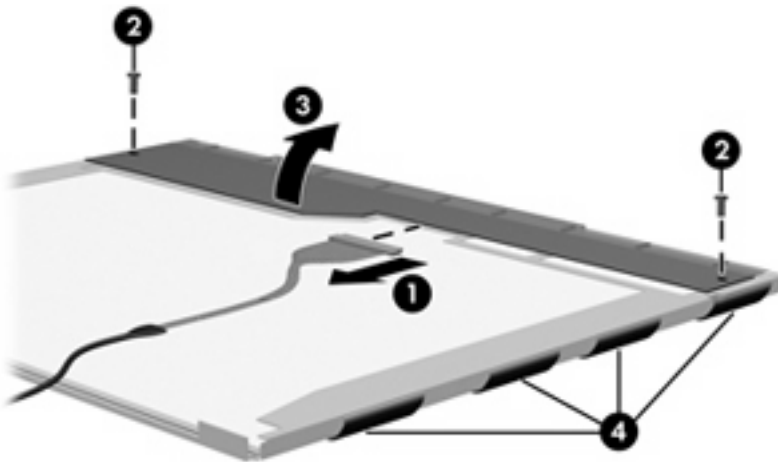

23. Remove the LCD panel.

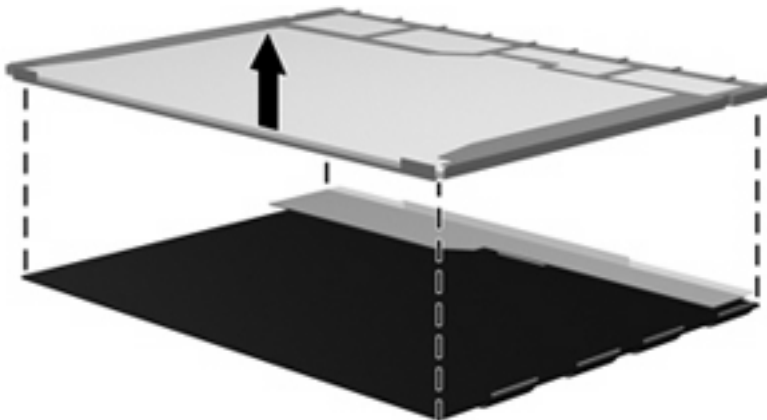

24. Recycle the LCD panel and backlight.

Index

Symbols/Numerics

1394 port
location 16
pin assignments 143

A

AC adapter, spare part
numbers 28, 29
accessory battery connector 17
AHCI (Advanced Host Controller Interface) 99
ambient light sensor 8
antenna
components 9
disconnecting 56, 63
locations 9
spare part number 20, 30
audio, product description 3
audio-in jack
location 16
pin assignments 144
audio-out jack
location 16
pin assignments 144
audio/ExpressCard assembly
removal 89
spare part number 23, 29, 89

B

backing up 132
backup
changes to your system 129
files and folders 132, 140
hard drive 132, 139
modifications made to the system 141
scheduling 132, 142
base enclosure, spare part number 23, 29

battery
removal 43
spare part numbers 23, 29, 43
battery (travel), spare part number 28, 29
battery bay 17
battery light 12, 14
battery release latch 17
BIOS Administrator Password 97
Bluetooth compartment 14
Bluetooth module
removal 47
spare part number 24, 31, 47
Bluetooth module cable
illustrated 26
removal 87
Bluetooth module compartment cover
illustrated 25
removal 47
boot options 99
boot order 99
bottom components 17
built-in device
Bluetooth device radio 100
fingerprint reader 100
modem 100
Network Interface Controller (LAN) 100
Wake on LAN 100
wireless button 100
WWAN device radio 100
built-in device options 100
button
info 10
power 10
presentation 10

volume mute 10
wireless 10
button components 10
buttons
display release 14
keyboard light 8

C

Cable Kit
contents 26
spare part number 21, 26, 33
cables, service considerations 36
caps lock light 12
chipset, product description 1
CMOS clearing 40
components
antenna 9
bottom 17
buttons 10
display 8
fingerprint reader 10
front 14
keys 11
left-side 16
lights 12
pointing device 13
rear 15
right-side 15
switches 10
top 8
wireless antenna 9
computer feet
locations 42
spare part number 42
Computer Setup
accessing 95
Diagnostics menu 98
File menu 97
navigating and selecting 95

- restoring factory settings 96
- Security menu 97
- System Configuration
 - menu 99
 - using 95
- computer specifications 101
- connectors
 - accessory battery 17
 - docking 17
 - service considerations 36
- creating recovery points 141

D

- device configurations 99
- Diagnostics menu 98
- Disk Sanitizer 98
- diskette drive, precautions 36
- display assembly
 - removal 77
 - spare part numbers 20, 32, 33, 77
- display bezel
 - removal 80
 - spare part numbers 20, 33, 80
- Display Cable Kit, spare part number 20, 30
- display component recycling 150
- display components 8
- display hinge
 - removal 81
 - spare part number 81
- Display Hinge Kit, spare part number 20, 30, 81
- display inverter
 - removal 45
 - spare part number 20, 33, 45
- display release button 14
- display specifications 102
- docking connector 17
- drive light 12, 14
- DriveLock password 98
- DriveLock, automatic 98
- drives
 - boot order 99
 - preventing damage 36
- Dual Core CPU 100
- DVD-ROM Drive
 - precautions 36

- removal 51
- spare part number 24, 27, 31, 51
- specifications 106

DVD/CD-RW Combo Drive

- precautions 36
- removal 51
- spare part number 24, 27, 31, 51
- specifications 105

DVD±RW and CD-RW Combo Drive

- precautions 36
- removal 51
- spare part number 24, 27, 31, 51
- specifications 104

E

- electrostatic discharge 37
- esc key 11
- Ethernet, product description 4
- Execution Disable 99
- ExpressCard slot 16
- ExpressCard slot bezel, illustrated 25
- external media cards, product description 4
- external monitor port
 - location 15
 - pin assignments 145

F

- f11 recovery 137
- f8 recovery tools
 - Recovery Manager 137
 - Windows Recovery Environment (WinRE) 136
- factory state, recovering to 137
- fan
 - removal 69
 - spare part number 21, 33, 69
- feet
 - locations 42
 - spare part number 42
- fingerprint reader 11

- fingerprint reader board
 - removal 86
 - spare part number 23, 32, 86
- fn key 11
- front components 14
- function keys 11

G

- graphics, product description 1
- grounding equipment and methods 39

H

- hard disk test 98
- hard drive
 - precautions 36
 - product description 2
 - removal 49
 - spare part numbers 24, 27, 31, 49
 - specifications 103
- hard drive backup 132, 139
- hard drive bay 17
- hard drive bay cover
 - illustrated 25
 - removal 49
- hard drive bracket, removal 50
- hard drive recovery 130, 142
- headphone jack
 - location 16
 - pin assignments 144
- heat sink
 - removal 70
 - spare part numbers 21, 31, 70
- hinge
 - removal 81
 - spare part number 20, 30, 81
- HP QuickLook 99
- HP SpareKey Enrollment 97

I

- I/O address specifications 109
- IDE (Integrated Drive Electronics) 99
- info button 10
- internal display switch 10
- interrupt specifications 108

- J**
- jacks
 - audio-in 16
 - audio-out 16
 - headphone 16
 - microphone 16
 - modem 15
 - network 15
 - RJ-11 15
 - RJ-45 15
- K**
- key components 11
- keyboard
 - product description 5
 - removal 57
 - spare part numbers 20, 30, 57
- keyboard light 8
- keyboard light button 8
- keyboard shield
 - removal 67
- keypad keys 11
- keys
 - esc 11
 - fn 11
 - function 11
 - keypad 11
 - Windows applications 11
 - Windows logo 11
- L**
- LAN Power Save 99
- language, changing in Computer Setup 99
- left-side components 16
- legacy support, USB 95, 99
- light components 12
- lights
 - battery 12, 14
 - caps lock 12
 - drive 12, 14
 - keyboard 8
 - num lock 13
 - power 12, 14
 - volume down 13
 - volume mute 13
 - volume up 13
 - webcam 8
 - wireless 12, 14
- Logo Kit, spare part number 20, 34
- M**
- manual restore points 133
- mass storage devices, spare part numbers 27
- memory map specifications 111
- memory module
 - product description 2
 - removal 54, 59
 - spare part numbers 22, 24, 31, 54, 59
- memory module compartment 17
- memory module compartment cover
 - illustrated 25
 - removal 54
- microphone 8
- microphone jack
 - location 16
 - pin assignments 144
- model name 1
- modem jack
 - location 15
 - pin assignments 146
- modem module
 - product description 4
 - removal 61
 - spare part numbers 22, 29, 61
- modem module cable
 - illustrated 26
 - removal 90
- monitor port
 - location 15
 - pin assignments 145
- N**
- network jack
 - location 15
 - pin assignments 146
- num lock light 13
- O**
- operating system, product description 5
- optical drive
 - precautions 36
 - product description 3
 - removal 51
- spare part numbers 24, 27, 51
- specifications 104, 105, 106
- P**
- packing guidelines 38
- panels, product description 1
- parallel port mode 99
- password clearing 40
- passwords 97
- pin assignments
 - 1394 port 143
 - audio-in jack 144
 - audio-out jack 144
 - external monitor port 145
 - headphone jack 144
 - microphone jack 144
 - modem jack 146
 - monitor port 145
 - network jack 146
 - RJ-11 146
 - RJ-45 jack 146
 - Universal Serial Bus (USB) port 147
- plastic parts 35
- Plastics Kit
 - contents 25
 - spare part number 21, 25, 33
- pointing device components 13
- pointing devices, product description 5
- pointing stick 13
- pointing stick button 13
- pointing stick rubber caps, spare part number 21, 32, 57
- port options
 - 1394 port 100
 - flash media reader 100
 - parallel port 100
 - serial port 100
 - USB port 100
- ports
 - 1394 16
 - external monitor 15
 - monitor 15
 - product description 4
 - USB 15, 16
- power button 10

- power button board
 - removal 68
 - spare part number 20, 30, 68
- power connector 15
- power cord
 - set requirements 148
 - spare part numbers 28, 33
- power light 12, 14
- power requirements, product description 5
- presentation button 10
- processor
 - product description 1
 - removal 75
 - spare part numbers 21, 32, 75
- product description
 - audio 3
 - chipset 1
 - Ethernet 4
 - external media cards 4
 - graphics 1
 - hard drives 2
 - keyboard 5
 - memory module 2
 - modem module 4
 - operating system 5
 - optical drives 3
 - panels 1
 - pointing devices 5
 - ports 4
 - power requirements 5
 - processors 1
 - product name 1
 - security 5
 - serviceability 7
 - upgrade bay 3
 - video 3
 - wireless 4
- product name 1
- R**
- RAID (Redundant Array of Independent Disks) 99
- rear components 15
- recovering to factory state 137
- recovery discs, creating 130
- Recovery Manager 137
 - recovery methods
 - Backup and Restore Center 130
 - Recovery Manager 137
 - Windows Recovery Environment (WinRE) 136
 - Windows Vista operating system DVD 138
 - recovery partition 134
 - recovery points 141
 - removal/replacement preliminaries 35
 - procedures 41
 - restore points 135
 - restore security defaults 100
 - restoring the factory settings 96
 - right-side components 15
 - RJ-11 jack
 - location 15
 - pin assignments 146
 - RJ-45 jack
 - location 15
 - pin assignments 146
 - RTC battery
 - removal 65
 - spare part number 23, 29, 65
 - Rubber Kit, spare part number 24, 30
 - run-in test 98
- S**
- scheduling backups 142
- Screw Kit
 - contents 112
 - spare part number 28, 32
- screw listing 112
- SD card reader 14
- Secondary Battery Fast Charge 99
- security cable slot 15
- Security menu
 - Automatic DriveLock 98
 - change password 97
 - Disk Sanitizer 98
 - DriveLock 98
 - fingerprint reader reset 97
 - HP SpareKey 97
 - password policy 97
- System IDs 98
 - user management 97
- security, product description 5
- serial number 18
- service considerations 35
- service tag 41
- serviceability, product description 7
- set security level 100
- SIM slot 17
- SIM, removal 44
- smart card reader 15
- solid-state drive, spare part number 24, 27, 32
- speaker
 - removal 88
 - spare part number 23, 32, 88
- speakers 14
- specifications
 - computer 101
 - display 102
 - DVD-ROM Drive 106
 - DVD/CD-RW Combo Drive 105
 - DVD±RW and CD-RW Combo Drive 104
 - hard drive 103
 - I/O addresses 109
 - interrupts 108
 - memory map 111
 - optical drive 104, 105, 106
 - system DMA 107
- start-up test 98
- static-shielding materials 39
- switch components 10
- switch cover
 - removal 66
 - spare part number 20, 32, 66
- system backup 129, 139
- system board
 - removal 92
 - spare part numbers 23, 32, 92
- System Configuration menu 99
- System Diagnostics menu 98
- system DMA 107
- system fan 99
- system IDs 98

- system information 97
- system memory map 111
- system points 135
- system recovery points 141

T

- thermal material,
 - replacement 72, 74
- tools required 35
- top components 8
- top cover
 - removal 82
 - spare part number 23, 32, 82
- TouchPad
 - location 13
 - spare part number 23, 32
- TouchPad board
 - removal 84
 - spare part number 84
- TouchPad bracket, removal 85
- TouchPad button 13
- TouchPad button board
 - removal 84
 - spare part number 84
- TouchPad scroll zone 13
- transporting guidelines 38
- travel battery, spare part number 28, 29
- TXT (Intel Trusted Execution Technology) 100

U

- unknown password 40
- upgrade bay 15
- upgrade bay device
 - removal 52
 - spare part number 52
- upgrade bay device cradle
 - spare part number 24, 27, 34
- upgrade bay, product description 3
- USB legacy support 95, 99
- USB port
 - location 15, 16
 - pin assignments 147
- using automatic restore points 133

V

- vents 16, 17
- video, product description 3
- Virtualization Technology 100
- volume down light 13
- volume mute button 10
- volume mute light 13
- volume scroll zone 11
- volume up light 13

W

- webcam
 - location 8
 - spare part number 20, 32
- webcam light 8
- Windows applications key 11
- Windows logo key 11
- Windows Recovery Environment (WinRE) 136
- Windows Vista operating system DVD 138
- wireless antenna
 - components 9
 - disconnecting 56, 63
 - locations 9
 - spare part number 20, 30
- Wireless Antenna Kit, spare part number 20, 30
- wireless button 10
- wireless light 12, 14
- wireless, product description 4
- WLAN module
 - removal 62
 - spare part numbers 22, 29, 32, 62
- workstation guidelines 38
- WWAN module
 - removal 55
 - spare part number 24, 32, 55
- WWAN module compartment 17
- WWAN module compartment cover
 - illustrated 25
 - removal 55

