

HP Compaq 6715b and 6715s Notebook PC and
HP Compaq 6710b and 6710s Notebook PC
Maintenance and Service Guide



© Copyright 2007 Hewlett-Packard
Development Company, L.P.

AMD, Sempron, Turion, and combinations thereof, are trademarks of Advanced Micro Devices, Inc. Bluetooth is a trademark owned by its proprietor and used by Hewlett-Packard Company under license. Intel and Core are trademarks or registered trademarks of Intel Corporation or its subsidiaries in the United States and other countries. Java is a US trademark of Sun Microsystems, Inc. Microsoft, Windows, and Windows Vista are either trademarks or registered trademarks of Microsoft Corporation in the United States and/or other countries. SD Logo is a trademark of its proprietor.

The information contained herein is subject to change without notice. The only warranties for HP products and services are set forth in the express warranty statements accompanying such products and services. Nothing herein should be construed as constituting an additional warranty. HP shall not be liable for technical or editorial errors or omissions contained herein.

Second Edition: April 2007

First Edition: March 2007

Document Part Number: 443119-002

Safety warning notice

- ⚠ **WARNING!** To reduce the possibility of heat-related injuries or of overheating the computer, do not place the computer directly on your lap or obstruct the computer air vents. Use the computer only on a hard, flat surface. Do not allow another hard surface, such as an adjoining optional printer, or a soft surface, such as pillows or rugs or clothing, to block airflow. Also, do not allow the AC adapter to contact the skin or a soft surface, such as pillows or rugs or clothing, during operation. The computer and the AC adapter comply with the user-accessible surface temperature limits defined by the International Standard for Safety of Information Technology Equipment (IEC 60950).
-

Table of contents

1 Product description

2 External component identification

Top components	11
Buttons, switches, and fingerprint reader	11
Keys	13
Lights	14
TouchPad	15
Front components	16
Left-side components	17
Rear components	18
Right-side components	19
Bottom components	20

3 Illustrated parts catalog

Serial number location	21
Computer major components	22
Plastics Kit	30
Cable Kit	31
Mass storage devices	32
Miscellaneous parts	33
Sequential part number listing	34

4 Removal and replacement procedures

Preliminary replacement requirements	41
Tools required	41
Service considerations	41
Plastic parts	41
Cables and connectors	42
Drive handling	42
Grounding guidelines	43
Electrostatic discharge damage	43
Packaging and transporting guidelines	44
Workstation guidelines	44
Equipment guidelines	45
Unknown user password	46
Component replacement procedures	47
Serial number	47

Battery	48
SIM	49
Display inverter	50
Hard drive	52
Computer feet	54
Bluetooth module	54
Expansion memory module	56
WLAN module	58
Optical drive	62
Keyboard	64
Internal memory module	66
RTC battery	67
WWAN module	68
Switch cover	70
Fan	71
Heat sink	72
Processor	74
Display assembly	76
Top cover	81
Speaker assembly	85
USB/Media Card Reader board	86
System board	88
PC Card/audio board assembly	91
Modem module	92
SIM slot board	94

5 Computer Setup

Starting Computer Setup	97
Using Computer Setup	98
Navigating and selecting in Computer Setup	98
Restoring factory settings in Computer Setup	98
Computer Setup menus	99
File menu	99
Security menu	100
Diagnostics menu	100
System Configuration menu	101

6 Specifications

Computer specifications	103
15.4-inch, WSXGA display specifications	104
15.4-inch, WXGA display specifications	105
Hard drive specifications	106
Primary 6-cell, Li-ion battery specifications	107
DVD±RW and CD-RW Super Multi Double-Layer Combo Drive specifications	108
DVD/CD-RW Combo Drive specifications	109
DVD-ROM drive	110
System DMA specifications	111
System interrupt specifications	112
System I/O address specifications	113

System memory map specifications	115
--	-----

7 Screw listing

Torx T8M2.5×7.0 screw	117
Phillips PM2.0×5.0 captive screw	118
Phillips PM2.5×13.0 captive screw	119
Phillips PM3.0×3.0 screw	120
Phillips PM2.5×3.0 screw	121
Torx T8M2.5×9.0 screw	123
Phillips PM2.0×3.0 screw	125
Black Phillips PM2.5×8.0 captive screw	126
Silver Phillips PM2.5×8.0 captive screw	127
Phillips PM2.5×8.0 screw	128
Phillips PM2.0×6.0 screw	129
Torx T8M2.5×6.0 screw	130
Hex HM5.0×9.0 screw lock	131
Phillips PM2.5×5.0 screw	132
Phillips PM2.5×3.0 broad-head screw	134

8 Backup and recovery in Windows Vista

Creating recovery discs	135
Backing up your information	136
When to back up	136
Backup suggestions	136
Backing up specific files or folders	137
Backing up the entire hard drive	137
Creating recovery points	138
Scheduling backups	138
Performing a recovery	139
Performing a recovery from the recovery discs	139
Performing a recovery from the hard drive	139
Initiating a recovery in Windows	140
Initiating a recovery from the hard drive recovery partition	140

9 Backup and recovery in Windows XP

Creating recovery discs	141
Backing up your information	142
When to back up	142
Backup suggestions	142
Backing up specific files or folders	143
Backing up the entire hard drive	143
Creating recovery points	144
Scheduling backups	144
Performing a recovery	145
Performing a recovery from the recovery discs	145
Performing a recovery from the hard drive	145
Initiating a recovery in Windows	146
Initiating a recovery from the hard drive recovery partition	146

10 Connector pin assignments

Audio-out (headphone)	147
Audio-in (microphone)	147
External monitor	148
RJ-11 (modem)	149
RJ-45 (network)	149
S-Video-out	150
Universal Serial Bus	150

11 Power cord set requirements

Requirements for all countries and regions	151
Requirements for specific countries and regions	152

12 Recycling

Battery	153
Display	153

Index	159
--------------------	------------

1 Product description

Category	Description	HP Compaq 6715s Notebook PC	HP Compaq 6715b Notebook PC without WWAN	HP Compaq 6715b Notebook PC with WWAN
Processors	AMD Turion™ 64 Mobile Technology processors:	√	√	√
	<ul style="list-style-type: none"> TL-64 (dual-core) 2.2-GHz processor with 1 MB of L2 cache MK-38 (single-core) 2.2-GHz processor with 512 KB of L2 cache TL-60 (dual-core) 2.0-GHz processor with 1 MB of L2 cache TL-56 (dual-core) 1.8-GHz processor with 1 MB of L2 cache TL-52 (dual-core) 1.6-GHz processor with 1 MB of L2 cache TL-50 (dual-core) 1.6-GHz processor with 1 MB of L2 cache 			
	Mobile AMD Sempron™ processors:	√	√	√
	<ul style="list-style-type: none"> 3800+ 2.2-GHz processor with 256 KB of L2 cache 3600+ 2.0-GHz processor with 256 KB of L2 cache 3500+ 1.8-GHz processor with 512 KB of L2 cache 3400+ 1.8-GHz processor with 256 KB of L2 cache 			
Chipset	<ul style="list-style-type: none"> Northbridge: RS690T Southbridge: SB600 	√	√	√
Graphics	Unified Memory Architecture (UMA), integrated with shared video memory	√	√	√
Panels	<ul style="list-style-type: none"> 15.4-inch, WSXGA+ with WWAN and WLAN antenna transceivers and cables 			√

Category	Description	HP Compaq 6715s Notebook PC	HP Compaq 6715b Notebook PC without WWAN	HP Compaq 6715b Notebook PC with WWAN
	<ul style="list-style-type: none"> 15.4-inch, WXGA with WWAN and WLAN antenna transceivers and cables 			✓
	<ul style="list-style-type: none"> 15.4-inch, WXGA, BrightView with WLAN antenna transceivers and cables 	✓	✓	
	<ul style="list-style-type: none"> 15.4-inch, WSXGA+ with WLAN antenna transceivers and cables 	✓	✓	
	<ul style="list-style-type: none"> 15.4-inch, WXGA with WLAN antenna transceivers and cables 	✓	✓	
	<ul style="list-style-type: none"> Support privacy film 	✓	✓	✓
Memory	<ul style="list-style-type: none"> Two SODIMM slots, both customer-accessible/upgradable (memory slot under the keyboard must be populated first) DDRII PC2-5300 (667-MHz) Supports dual-channel memory <p>Supports the following configurations:</p> <ul style="list-style-type: none"> 4096 MB total system memory (2048 MB × 2, dual-channel) 2048 MB total system memory (2048 MB × 1) 2048 MB total system memory (1024 MB × 2, dual-channel) 1024 MB total system memory (512 MB × 2, dual-channel) 1024 MB total system memory (1024 MB × 1) 512 MB total system memory (512 MB × 1) 	✓	✓	✓
Hard drives	<ul style="list-style-type: none"> Supports all 9.5-mm, 2.5-inch hard drives Serial ATA <p>The following hard drives are available:</p> <ul style="list-style-type: none"> 160-GB, 5400-rpm 120-GB, 5400-rpm 80-GB, 7200- and 5400-rpm 	✓	✓	✓
Optical drives	<ul style="list-style-type: none"> 12.7-mm tray load Fixed, no modular requirements (1-screw removal) 	✓	✓	✓

Category	Description	HP Compaq 6715s Notebook PC	HP Compaq 6715b Notebook PC without WWAN	HP Compaq 6715b Notebook PC with WWAN
	<p>Supports all common optical formats including the following:</p> <ul style="list-style-type: none"> DVD±RW and CD-RW Super Multi Double-Layer Combo Drive with Lightscribe DVD±RW and CD-RW Super Multi Double-Layer Combo Drive DVD/CD-RW Combo Drive DVD-ROM drive 			
Diskette drive	Supports external USB drive only	√	√	√
Audio	<ul style="list-style-type: none"> Azalia Stereo speakers Integrated monoaural microphone Headphone and microphone jacks 	√	√	√
Modem	<ul style="list-style-type: none"> 56K data/fax modem (MDC1.5) Modem cable included in Brazil, the Czech Republic, France, Greece, Hungary, Israel, Latin America, Poland, Russia, Saudi Arabia, Slovakia, Slovenia, South Africa, Turkey, and the United Kingdom. 	√	√	√
Ethernet	<ul style="list-style-type: none"> Integrated Broadcom 5787 10/100/1000 LAN Integrated Broadcom 5906 10/100 LAN S4/S5 wake on LAN (on AC power only) Network interface card (NIC) power down 		√	√
Wireless	Integrated wireless options by way of wireless module			
	Wireless local area network (WLAN) options:			
	<ul style="list-style-type: none"> Broadcom 802.11a/b/g/n Broadcom 802.11a/b/g Broadcom 802.11b/g Option for no WLAN 		√	√
	Wireless wide area network (WWAN) options:			

Category	Description	HP Compaq 6715s Notebook PC	HP Compaq 6715b Notebook PC without WWAN	HP Compaq 6715b Notebook PC with WWAN
	<ul style="list-style-type: none"> Evolution-data optimized (EVDO) WWAN module 			✓
	<ul style="list-style-type: none"> High-speed downlink packet access (HSPDA) WWAN module 			✓
	<ul style="list-style-type: none"> Subscriber identity module (SIM) 			✓
	Wireless personal area network (WPAN) options:	✓	✓	✓
	<ul style="list-style-type: none"> Bluetooth® 2.0 module + Blueflame module Supports no WPAN option 			
External media card	<ul style="list-style-type: none"> One Type I/II PC Card slot, 16-bit PCMCIA and 32-bit CardBus 	✓	✓	✓
	<ul style="list-style-type: none"> Media Card Reader (MS Duo adapters, plus SD, MMC, MS, MSPro, and xD) 		✓	✓
Ports	<ul style="list-style-type: none"> 1394a port 		✓	✓
	<ul style="list-style-type: none"> Docking connector 		✓	✓
	<ul style="list-style-type: none"> Headphone connector 	✓	✓	✓
	<ul style="list-style-type: none"> Microphone connector 	✓	✓	✓
	<ul style="list-style-type: none"> Primary battery connector 	✓	✓	✓
	<ul style="list-style-type: none"> RJ-11 modem port 	✓	✓	✓
	<ul style="list-style-type: none"> RJ-45 Ethernet port 	✓	✓	✓
	<ul style="list-style-type: none"> S-Video-out connector 		✓	✓
	<ul style="list-style-type: none"> Smart AC adapter connector 	✓	✓	✓
	<ul style="list-style-type: none"> Travel battery connector 	✓	✓	✓
	<ul style="list-style-type: none"> USB ports (4) 		✓	✓
	<ul style="list-style-type: none"> USB ports (2) 	✓		
	<ul style="list-style-type: none"> VGA port (Dsub 15-pin) supporting 1600 × 1200 external resolution @ 75 Hz, hot plug/unplug, and auto detect 	✓	✓	✓
Docking	Docking support		✓	✓
Keyboard/ pointing devices	<ul style="list-style-type: none"> Spill-resistant keyboard with embedded numeric keypad, TouchPad, and fingerprint reader 		✓	✓
	<ul style="list-style-type: none"> Spill-resistant keyboard with embedded numeric keypad and TouchPad 	✓		
	<ul style="list-style-type: none"> Two-way scrolling 	✓	✓	✓

Category	Description	HP Compaq 6715s Notebook PC	HP Compaq 6715b Notebook PC without WWAN	HP Compaq 6715b Notebook PC with WWAN
	<ul style="list-style-type: none"> Windows Vista™ hardware Start button 	√	√	√
Power requirements	Primary batteries: <ul style="list-style-type: none"> 6-cell, 2.55-Ah Li-ion battery (55 Whr) 6-cell, 2.20-Ah Li-ion battery (47 Whr) Travel batteries: <ul style="list-style-type: none"> 12-cell Li-ion battery 8-cell Li-ion battery AC adapter: <ul style="list-style-type: none"> 90-watt Localized cable plug support 3-wire plug with ground pin Supports multipin AC connector) 	√	√	√
Security	<ul style="list-style-type: none"> Fingerprint reader 		√	√
	<ul style="list-style-type: none"> HP 3D DriveGuard 		√	√
	<ul style="list-style-type: none"> HP DriveGuard 	√		
	<ul style="list-style-type: none"> Security cable slot 	√	√	√
	<ul style="list-style-type: none"> Smart card reader/bezel snap-in 	√	√	√
	<ul style="list-style-type: none"> Trusted platform module (TPM) 1.2 on system board 		√	√
Operating system	Preinstalled:			
	<ul style="list-style-type: none"> Windows Vista Home Basic 	√	√	√
	<ul style="list-style-type: none"> Windows Vista Business 32/64 	√	√	√
	<ul style="list-style-type: none"> FreeDOS 	√	√	√
	<ul style="list-style-type: none"> Windows® XP Professional 		√	√
	Certified: SuSe Linux Enterprise Desktop (SLED) 10	√	√	√
	Supported:			
	<ul style="list-style-type: none"> Windows Vista Enterprise 		√	√
	<ul style="list-style-type: none"> Windows XP Professional 	√	√	√
Serviceability	End-user replaceable parts:	√	√	√
	<ul style="list-style-type: none"> AC adapter Hard drive 			

Category	Description	HP Compaq 6715s Notebook PC	HP Compaq 6715b Notebook PC without WWAN	HP Compaq 6715b Notebook PC with WWAN
	<ul style="list-style-type: none"> Memory module Optical drive Primary battery WLAN module WWAN module 			

Category	Description	HP Compaq 6710s Notebook PC	HP Compaq 6710b Notebook PC without WWAN	HP Compaq 6710b Notebook PC with WWAN
Processors	Intel® Core™ Duo processors: <ul style="list-style-type: none"> T7700 2.4-GHz processor with 800-MHz Front Side Bus (FSB) and 4 MB of L2 cache T7500 2.2-GHz processor with 800-MHz FSB and 4 MB of L2 cache T7300 2.0-GHz processor with 800-MHz FSB and 4 MB of L2 cache T7100 1.8-GHz processor with 800-MHz FSB and 2 MB of L2 cache 	√	√	√
Chipset	<ul style="list-style-type: none"> Northbridge: Intel GM965 with 800-MHz FSB Southbridge: ICH8M 	√	√	√
Graphics	Unified Memory Architecture (UMA), integrated with shared video memory	√	√	√
Panels	<ul style="list-style-type: none"> 15.4-inch, WSXGA+ with WLAN and WWAN antenna transceivers and cables 			√
	<ul style="list-style-type: none"> 15.4-inch, WXGA with WLAN and WWAN antenna transceivers and cables 			√
	<ul style="list-style-type: none"> 15.4-inch, WSXGA+ with WLAN antenna transceivers and cables 	√	√	
	<ul style="list-style-type: none"> 15.4-inch, BrightView, WXGA with WLAN antenna transceivers and cables 	√	√	
	<ul style="list-style-type: none"> 15.4-inch, WXGA with WLAN antenna transceivers and cables 	√	√	
	<ul style="list-style-type: none"> Support privacy film 	√	√	√

Category	Description	HP Compaq 6710s Notebook PC	HP Compaq 6710b Notebook PC without WWAN	HP Compaq 6710b Notebook PC with WWAN
Memory	<ul style="list-style-type: none"> Two SODIMM slots, both customer accessible/upgradable (memory slot under the keyboard must be populated first) DDRII PC2-5300 (667-MHz) Supports dual-channel memory <p>Supports the following configurations:</p> <ul style="list-style-type: none"> 4096 MB total system memory (2048 MB × 2, dual-channel) 2048 MB total system memory (2048 MB × 1) 2048 MB total system memory (1024 MB × 2, dual-channel) 1024 MB total system memory (512 MB × 2, dual-channel) 1024 MB total system memory (1024 MB × 1) 512 MB total system memory (512 MB × 1) 	√	√	√
Hard drives	<ul style="list-style-type: none"> Supports all 9.5-mm, 2.5-inch hard drives Serial ATA <p>The following hard drives are available:</p> <ul style="list-style-type: none"> 160-GB, 5400-rpm 120-GB, 5400-rpm 80-GB, 7200- and 5400-rpm 	√	√	√
Optical drives	<ul style="list-style-type: none"> 12.7-mm tray load Fixed, no modular requirements (1-screw removal) <p>Supports all common optical formats including the following:</p> <ul style="list-style-type: none"> DVD±RW and CD-RW Super Multi Double-Layer Combo Drive with Lightscribe DVD±RW and CD-RW Super Multi Double-Layer Combo Drive DVD/CD-RW Combo Drive DVD-ROM drive 	√	√	√
Diskette drive	Supports external USB drive only	√	√	√

Category	Description	HP Compaq 6710s Notebook PC	HP Compaq 6710b Notebook PC without WWAN	HP Compaq 6710b Notebook PC with WWAN
Audio	• Azalia	✓	✓	✓
	• Stereo speakers			
	• Integrated monoaural microphone			
	• Headphone and microphone jacks			
Modem	• 56K data/fax modem (MDC1.5)	✓	✓	✓
	• Modem cable included in Brazil, the Czech Republic, France, Greece, Hungary, Israel, Latin America, Poland, Russia, Saudi Arabia, Slovakia, Slovenia, South Africa, Turkey, and the United Kingdom.			
Ethernet	• Integrated Broadcom 5787 10/100/1000 LAN		✓	✓
	• Integrated Broadcom 5906 10/100 LAN	✓		
	• S4/S5 wake on LAN (on AC power only)	✓	✓	✓
	• Network interface card (NIC) power down	✓	✓	✓
Wireless	Integrated wireless options by way of wireless module			
	Wireless local area network (WLAN) options:			
	• Broadcom 802.11a/b/g/n		✓	✓
	• Broadcom 802.11a/b/g	✓	✓	✓
	• Broadcom 802.11b/g	✓	✓	✓
	• Option for no WLAN	✓	✓	
	Wireless wide area network (WWAN) options:			
	• Evolution-data optimized (EVDO) WWAN module			✓
	• High-speed downlink packet access (HSPDA) WWAN module			✓
	• Subscriber identity module (SIM)			✓
	Wireless personal area network (WPAN) options:	✓	✓	✓
	• Bluetooth® 2.0 module + Blueflame module			
	• Supports no WPAN option			

Category	Description	HP Compaq 6710s Notebook PC	HP Compaq 6710b Notebook PC without WWAN	HP Compaq 6710b Notebook PC with WWAN
External media card	<ul style="list-style-type: none"> One Type I/II PC Card slot, 16-bit PCMCIA and 32-bit CardBus 	√	√	√
	<ul style="list-style-type: none"> Media Card Reader (MS Duo adapters, plus SD, MMC, MS, MSPro, and xD) 		√	√
Ports	<ul style="list-style-type: none"> 1394a port 		√	√
	<ul style="list-style-type: none"> Docking connector 		√	√
	<ul style="list-style-type: none"> Headphone connector 	√	√	√
	<ul style="list-style-type: none"> Microphone connector 	√	√	√
	<ul style="list-style-type: none"> Primary battery connector 	√	√	√
	<ul style="list-style-type: none"> RJ-11 modem port 	√	√	√
	<ul style="list-style-type: none"> RJ-45 Ethernet port 	√	√	√
	<ul style="list-style-type: none"> S-Video-out connector 		√	√
	<ul style="list-style-type: none"> Smart AC adapter connector 	√	√	√
	<ul style="list-style-type: none"> Travel battery connector 	√	√	√
	<ul style="list-style-type: none"> USB ports (4) 		√	√
	<ul style="list-style-type: none"> USB ports (2) 	√		
	<ul style="list-style-type: none"> VGA port (Dsub 15-pin) supporting 1600 × 1200 external resolution @ 75 Hz, hot plug/unplug, and auto detect 	√	√	√
Docking	Docking support		√	√
Keyboard/ pointing devices	<ul style="list-style-type: none"> Spill-resistant keyboard with embedded numeric keypad, TouchPad, and fingerprint reader 		√	√
	<ul style="list-style-type: none"> Spill-resistant keyboard with embedded numeric keypad and TouchPad 	√		
	<ul style="list-style-type: none"> Two-way scrolling 	√	√	√
	<ul style="list-style-type: none"> Windows Vista™ hardware Start button 	√	√	√
Power requirements	Primary batteries:	√	√	√
	<ul style="list-style-type: none"> 6-cell, 2.55-Ah Li-ion battery (55 Whr) 			
	<ul style="list-style-type: none"> 6-cell, 2.20-Ah Li-ion battery (47 Whr) 			
	Travel batteries:			
	<ul style="list-style-type: none"> 12-cell Li-ion battery 			
	<ul style="list-style-type: none"> 8-cell Li-ion battery 			
	AC adapter:			

Category	Description	HP Compaq 6710s Notebook PC	HP Compaq 6710b Notebook PC without WWAN	HP Compaq 6710b Notebook PC with WWAN
	<ul style="list-style-type: none"> • 90-watt • Localized cable plug support • 3-wire plug with ground pin • Supports multipin AC connector 			
Security	<ul style="list-style-type: none"> • Fingerprint reader 		✓	✓
	<ul style="list-style-type: none"> • HP 3D DriveGuard 		✓	✓
	<ul style="list-style-type: none"> • HP DriveGuard 	✓		
	<ul style="list-style-type: none"> • Security cable slot 	✓	✓	✓
	<ul style="list-style-type: none"> • Smart card reader/bezel snap-in 	✓	✓	✓
	<ul style="list-style-type: none"> • Trusted platform module (TPM) 1.2 on system board 		✓	✓
Operating system	Preinstalled:			
	<ul style="list-style-type: none"> • Windows Vista Home Basic 	✓	✓	✓
	<ul style="list-style-type: none"> • Windows Vista Business 32/64 	✓	✓	✓
	<ul style="list-style-type: none"> • FreeDOS 	✓	✓	✓
	<ul style="list-style-type: none"> • Windows® XP Professional 		✓	✓
	Certified: SuSe Linux Enterprise Desktop (SLED) 10	✓	✓	✓
	Supported:			
	<ul style="list-style-type: none"> • Windows Vista Enterprise 		✓	✓
	<ul style="list-style-type: none"> • Windows XP Professional 	✓		
Serviceability	End-user replaceable parts:	✓	✓	✓
	<ul style="list-style-type: none"> • AC adapter • Hard drive • Memory module • Optical drive • Primary battery • WLAN module • WWAN module 			

2 External component identification

Top components

Buttons, switches, and fingerprint reader



Item	Component	Function
(1)	Power button	<ul style="list-style-type: none">• When the computer is off, press the button to turn on the computer.• When the computer is on, press the button to shut down the computer.• When the computer is in the Sleep state (Windows Vista) or in Standby (Windows XP), press the button briefly to exit Sleep or Standby.• When the computer is in Hibernation, press the button briefly to exit Hibernation. <p>If the computer has stopped responding and Windows® shutdown procedures are ineffective, press and hold the power button for at least 5 seconds to turn off the computer.</p>

Item	Component	Function
		<p>To learn more about power settings, follow these steps:</p> <ul style="list-style-type: none"> • In Windows Vista, select Start > Control Panel > System and Maintenance > Power Options. • In Windows XP, select Start > Control Panel > Performance and Maintenance > Power Options.
(2)	Internal display switch	Turns off the display if the display is closed while the power is on.
(3)	Info button (select models only)	Launches Info Center, which enables you to open various software solutions.
(4)	Wireless button	<p>Turns the wireless feature on or off, but does not establish a wireless connection.</p> <p>NOTE: A wireless network must be set up in order to establish a wireless connection.</p>
(5)	Presentation button (select models only)	Starts the presentation feature.
(6)	Volume mute button (select models only)	Mutes and restores speaker sound.
(7)	Volume scroll zone (select models only)	Adjusts speaker volume. Slide your finger to the left to decrease volume and to the right to increase volume. You can also tap the minus sign on the scroll zone to decrease volume, or tap the plus sign on the scroll zone to increase volume.
(8)	Internal microphone (select models only)	Records sound.
(9)	Fingerprint reader (select models only)	Allows a fingerprint logon to Windows, instead of a password logon.

Keys

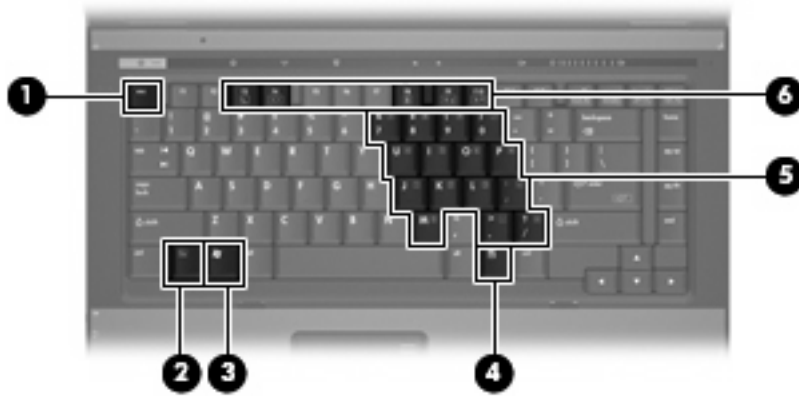

Item	Component	Function
(1)	esc key	Displays system information when pressed in combination with the <code>fn</code> key.
(2)	<code>fn</code> key	Executes frequently used system functions when pressed in combination with a function key or the <code>esc</code> key.
(3)	Windows logo key	Displays the Windows Start menu.
(4)	Windows applications key	Displays a shortcut menu for items beneath the pointer.
(5)	Embedded numeric keypad keys	Can be used like the keys on an external numeric keypad.
(6)	Function keys	Execute frequently used system functions when pressed in combination with the <code>fn</code> key.

Lights



Item	Component	Function
(1)	Power lights (2)	<ul style="list-style-type: none"> On: The computer is on. Blinking: The computer is in the Sleep state (Windows Vista) or in Standby (Windows XP). Blinking rapidly: An AC adapter with a higher power rating must be connected. Off: The computer is off or in Hibernation.
(2)	Wireless lights (2)	<ul style="list-style-type: none"> On: An integrated wireless device, such as a wireless local area network (WLAN) device, a wireless wide-area network (WWAN) device, and/or a Bluetooth device is turned on. Off: All wireless devices are turned off.
(3)	Caps lock light	On: Caps lock is on.
(4)	Num lock light	On: Num lock is on or the embedded numeric keypad is enabled.
(5)	Volume mute light (select models only)	<ul style="list-style-type: none"> Off: Computer sound is turned on. On: Computer sound is turned off.
(6)	Volume down light (select models only)	Blinking: The volume scroll zone is being used to decrease speaker volume.
(7)	Volume up light (select models only)	Blinking: The volume scroll zone is being used to increase speaker volume.
(8)	Battery light	<ul style="list-style-type: none"> Amber: A battery is charging. Green: A battery is close to full charge capacity. Blinking amber: A battery that is the only available power source has reached a low battery level. When the battery

Item	Component	Function
		reaches a critical battery level, the battery light begins blinking rapidly.
		<ul style="list-style-type: none"> Off: If the computer is plugged into an external power source, the light turns off when all batteries in the computer are fully charged. If the computer is not plugged into an external power source, the light stays off until the battery reaches a low battery level.
(9)	Drive light	<ul style="list-style-type: none"> Blinking green: The hard drive or optical drive is being accessed. Amber: HP 3D DriveGuard has temporarily parked the internal hard drive.

TouchPad

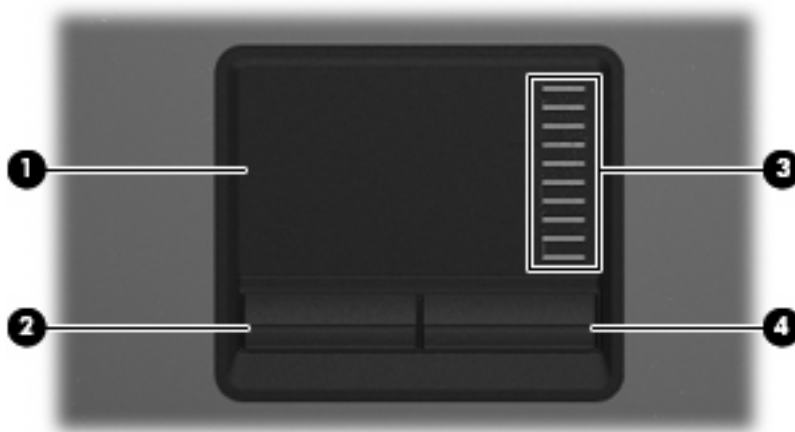

Item	Component	Function
(1)	TouchPad*	Moves the pointer and selects or activates items on the screen.
(2)	Left TouchPad button*	Functions like the left button on an external mouse.
(3)	TouchPad scroll zone	Scrolls up or down.
(4)	Right TouchPad button*	Functions like the right button on an external mouse.

*This table describes factory settings. View or change pointing device preferences as follows:

- In Windows Vista, select **Start > Control Panel > Hardware and Sound > Mouse**.
- In Windows XP, select **Start > Control Panel > Printers and Other Hardware > Mouse**.

Front components

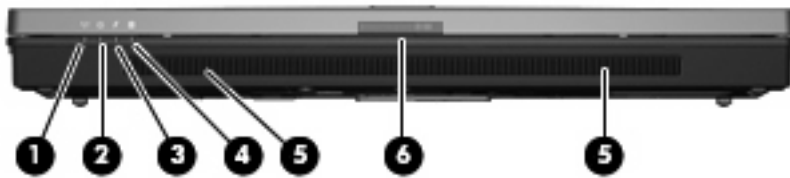

Item	Component	Function
(1)	Wireless light	<ul style="list-style-type: none"> On: An integrated wireless device, such as a WLAN device, a WWAN device, and/or a Bluetooth device, is turned on. Off: All wireless devices are turned off.
(2)	Power light	<ul style="list-style-type: none"> On: The computer is on. Blinking: The computer is in the Sleep state (Windows Vista) or in Standby (Windows XP). Blinking rapidly: An AC adapter with a higher power rating must be connected. Off: The computer is off or in Hibernation.
(3)	Battery light	<ul style="list-style-type: none"> Amber: A battery is charging. Green: A battery is close to full charge capacity. Blinking amber: A battery that is the only available power source has reached a low battery level. When the battery reaches a critical battery level, the battery light begins blinking rapidly. Off: If the computer is plugged into an external power source, the light turns off when all batteries in the computer are fully charged. If the computer is not plugged into an external power source, the light stays off until the battery reaches a low battery level.
(4)	Drive light	<ul style="list-style-type: none"> Blinking green: The hard drive or optical drive is being accessed. Amber (select models only): HP 3D DriveGuard has temporarily parked the hard drive.
(5)	Speakers	Produce sound.
(6)	Display release latch	Opens the computer.

Left-side components

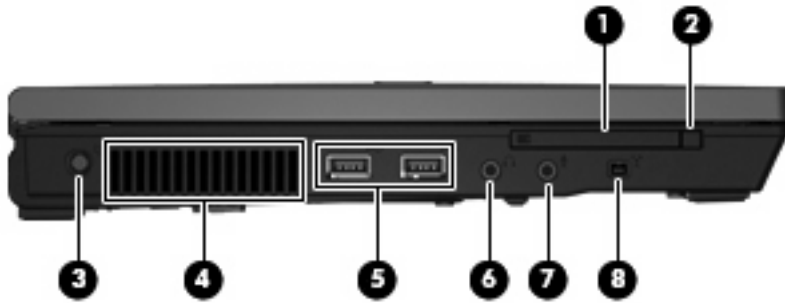

Item	Component	Function
(1)	PC Card slot	Supports optional Type I or Type II 32-bit (CardBus) or 16-bit PC Cards.
(2)	PC Card eject button	Ejects a PC Card from the PC Card slot.
(3)	Power connector	Connects an AC adapter.
(4)	Vent	Enables airflow to cool internal components. NOTE: The computer fan starts up automatically to cool internal components and prevent overheating. It is normal for the internal fan to cycle on and off during routine operation.
(5)	USB ports (2)	Connect optional USB devices.
(6)	Audio-out (headphone) jack	Produces sound when connected to optional powered stereo speakers, headphones, ear buds, a headset, or television audio.
(7)	Audio-in (microphone) jack	Connects an optional computer headset microphone, stereo array microphone, or monaural microphone.
(8)	1394 port (select models only)	Connects an optional IEEE 1394 or 1394a device, such as a camcorder.

Rear components



Item	Component	Function
(1)	Security cable slot	Attaches an optional security cable to the computer. NOTE: The security cable is designed to act as a deterrent, but it may not prevent the computer from being mishandled or stolen.
(2)	RJ-45 (network) jack	Connects a network cable.
(3)	External monitor port	Connects an external VGA monitor or projector.
(4)	S-Video-out jack	Connects an optional S-Video device such as a television, VCR, camcorder, overhead projector, or video capture card.

Right-side components



Item	Component	Function
(1)	Media Card Reader (select models only)	Supports the following optional digital card formats: <ul style="list-style-type: none">• Secure Digital (SD) Memory Card• MultiMediaCard (MMC)• Memory Stick (MS)• Memory Stick Pro (MSP)• Memory Stick Duo Adapter• xD-Picture Card (XD)
(2)	USB ports (2) (select models only)	Connect optional USB devices.
(3)	Optical drive	Reads optical discs, and, on select models, also writes to optical discs.
(4)	RJ-11 (modem) jack	Connects a modem cable.

Bottom components

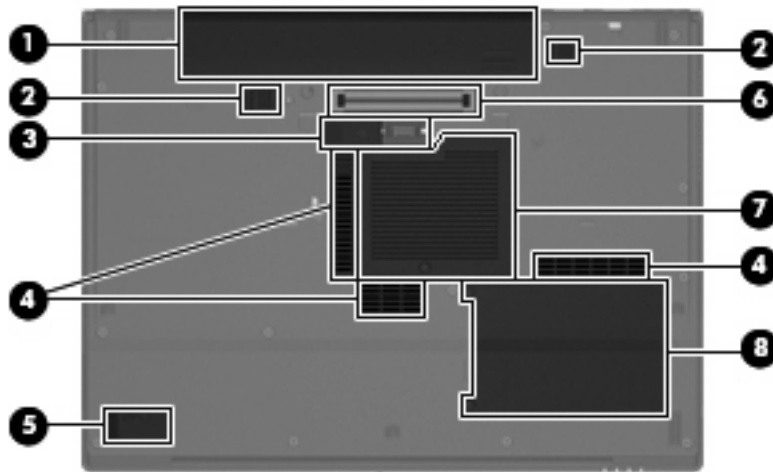

Item	Component	Function
(1)	Battery bay	Holds the battery.
(2)	Battery release latches (2)	Release the battery from the battery bay.
(3)	Accessory battery connector	Connects an optional accessory battery.
(4)	Vents (3)	Enable airflow to cool internal components. NOTE: The computer fan starts up automatically to cool internal components and prevent overheating. It is normal for the internal fan to cycle on and off during routine operation.
(5)	Bluetooth module compartment (select models only)	Contains a Bluetooth device.
(6)	Docking connector (select models only)	Connects an optional docking device.
(7)	Memory/WLAN module compartment	Contains the memory module slot and the WLAN module slot. CAUTION: To prevent an unresponsive system, replace the wireless module only with a wireless module authorized for use in the computer by the governmental agency that regulates wireless devices in your country or region. If you replace the module and then receive a warning message, remove the module to restore computer functionality, and then contact technical support through Help and Support.
(8)	Hard drive bay	Holds the hard drive.

3 Illustrated parts catalog

Serial number location

When ordering parts or requesting information, provide the computer serial number and model number located on the bottom of the computer.

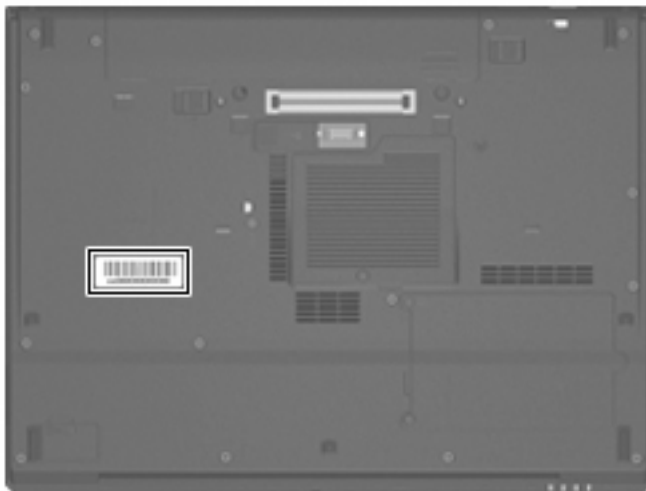

Computer major components

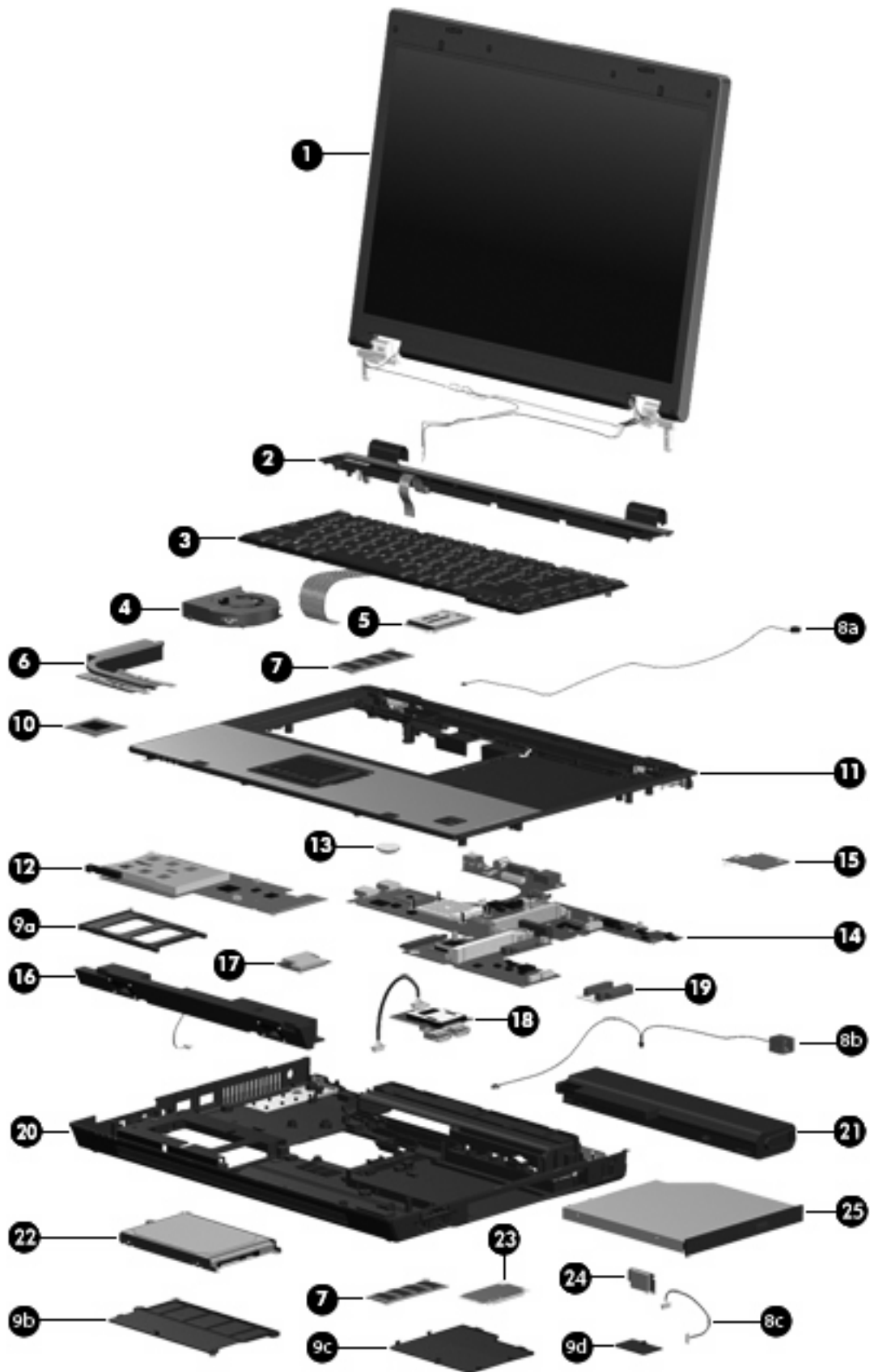

Item	Description	Spare part number
(1)	Display assemblies	
	15.4-inch, WSXGA+ display assembly for use with HP Compaq 6715b and 6710b computer models with WWAN capability	443814-001
	15.4-inch, WXGA display assembly for use with HP Compaq 6715b and 6710b computer models with WWAN capability	443817-001
	15.4-inch, WXGA, BrightView display assembly for use with HP Compaq 6715b and 6710b computer models without WWAN capability	443816-001
	15.4-inch, WSXGA+ display assembly for use with HP Compaq 6715b and 6710b computer models without WWAN capability	443813-001
	15.4-inch, WXGA display assembly for use with HP Compaq 6715b and 6710b computer models without WWAN capability	443815-001
	15.4-inch, WXGA, BrightView display assembly for use with HP Compaq 6715s and 6710s computer models	443812-001
	15.4-inch, WSXGA+ display assembly for use with HP Compaq 6715s and 6710s computer models	443818-001
	15.4-inch, WXGA display assembly for use with HP Compaq 6715s and 6710s computer models	443819-001
	Display assembly internal components	
	Display bezel	446871-001
	15.4-inch, WSXGA+ display panel for use with HP Compaq 6710b computer models with WWAN capability	446900-001
	15.4-inch, WXGA display panel for use with HP Compaq 6710b computer models with WWAN capability	446899-001
	15.4-inch, WSXGA+ display panel for use with HP Compaq 6710b computer models without WWAN capability	446897-001
	15.4-inch, WXGA, BrightView display panel for use with HP Compaq 6710b computer models without WWAN capability	446898-001
	15.4-inch, WXGA display panel for use with HP Compaq 6710b computer models without WWAN capability	446896-001
	15.4-inch, WSXGA+ display panel for use with HP Compaq 6710s computer models	446902-001
	15.4-inch, WXGA, BrightView display panel for use with HP Compaq 6710s computer models	446903-001
	15.4-inch, WXGA display panel for use with HP Compaq 6710s computer models	446901-001
	Display inverter (includes 2-sided tape)	446870-001
	Display left and right hinges	446882-001
	Display enclosure for use with HP Compaq 6715b and 6710b computer models	446883-001
	Display enclosure for use with HP Compaq 6715s and 6710s computer models	450612-001
(2)	Switch covers (include power button board and power button board cable)	
	For use with HP Compaq 6715b and 6710b computer models (includes LED board and cable)	443911-001
	For use with HP Compaq 6715s and 6710s computer models (does not include LED board and cable)	443910-001

Item	Description	Spare part number
(3)	Keyboards	
	Belgium	443811-181
	Brazil	443811-201
	The Czech Republic	443811-221
	Denmark	443811-081
	France	443811-051
	French Canada	443811-121
	Germany	443811-041
	Greece	443811-DJ1
	Hungary	443811-211
	International	443811-B31
	Iceland	443811-DD1
	Israel	443811-BB1
	Italy	443811-061
	Japan	443811-291
	Korea	443811-AD1
	Latin America	443811-161
	Norway	443811-091
	Portugal	443811-131
	Russia	443811-251
	Saudi Arabia	443811-171
	Slovakia	443811-231
	Slovenia	443811-BA1
	Spain	443811-071
	Sweden and Finland	443811-B71
	Switzerland	443811-BG1
	Taiwan	443811-AB1
	Thailand	443811-281
	Turkey	443811-141
	The United Kingdom	443811-031
	The United States	443811-001
(4)	Fan	443917-001
(5)	WWAN modules	
	EVDO WWAN module	399440-001

Item	Description	Spare part number
	Vodafone HSPDA WWAN module	448672-002
	Cingular HSPDA WWAN module	448673-002
(6)	Heat sinks (include thermal material)	
	For use with HP Compaq 6715 computer models	443912-001
	For use with HP Compaq 6710 computer models	446920-001
	Thermal Material Kits (not illustrated)	
	For use in all countries and regions except Japan and Asia/Pacific	413706-001
	For use in Japan and Asia/Pacific countries and regions	445853-001
(7)	Memory modules, 1-DIMM	
	2048-MB, PC2-5300	417506-001
	1024-MB, PC2-5300	414046-001
	512-MB, PC2-5300	414045-001
	Cable Kit (see Cable Kit on page 31 for more Cable Kit spare part information)	443887-001
(8a)	Microphone (includes receiver and cable)	
(8b)	Modem module cable (includes RJ-11 connector and cable)	
(8c)	Bluetooth module cable	
	Plastics Kit (see Plastics Kit on page 30 for more Plastics Kit spare part information)	443905-001
(9a)	PC Card slot bezel	
(9b)	Hard drive cover (includes 2 captive screws, secured by C-clips)	
(9c)	Memory/WLAN module compartment cover (includes 1 captive screw, secured by a C-clip)	
(9d)	Bluetooth module compartment cover (includes 1 captive screw, secure by a C-clip)	
	Computer feet (4 large rubber feet, 4 small rubber feet, not illustrated)	
(10)	Processors (include thermal material)	
	Processors for use with HP Compaq 6715 computer models in all countries and regions except Japan and Asia/Pacific:	
	AMD Turion TL-64 (2.2-GHz, 1-MB L2 cache)	443913-001
	AMD Turion MK-38 (2.2-GHz, 512-KB L2 cache)	446045-001
	AMD Turion TL-60 (2.0-GHz, 1-MB L2 cache)	430876-001
	AMD Turion TL-56 (1.8-GHz, 1-MB L2 cache)	430875-001
	AMD Turion TL-52 (1.6-GHz, 1-MB L2 cache)	430874-001
	AMD Turion TL-50 (1.6-GHz, 1-MB L2 cache)	450940-001
	Mobile AMD Sempron 3800+ (2.2-GHz, 256-KB L2 cache)	450939-001
	Mobile AMD Sempron 3600+ (2.0-GHz, 256-KB L2 cache)	443916-001
	Mobile AMD Sempron 3500+ (1.8-GHz, 512-KB L2 cache)	430872-001
	Mobile AMD Sempron 3400+ (1.8-GHz, 256-KB L2 cache)	430871-001

Item	Description	Spare part number
	Processors for use with HP Compaq 6715 computer models in Japan and Asia/Pacific countries and regions	
	AMD Turion TL-60 (2.0-GHz, 1-MB L2 cache)	443892-001
	AMD Turion TL-56 (1.8-GHz, 1-MB L2 cache)	443891-001
	AMD Turion TL-52 (1.6-GHz, 1-MB L2 cache)	443890-001
	Mobile AMD Sempron 3500+ (1.8-GHz, 512-KB L2 cache)	443915-001
	Mobile AMD Sempron 3400+ (1.8-GHz, 256-KB L2 cache)	443914-001
	Processors for use with HP Compaq 6710 computer models	
	Intel Core Duo T7700 2.4-GHz with 4-MB of L2 cache	446894-001
	Intel Core Duo T7500 2.2-GHz with 4-MB of L2 cache	446893-001
	Intel Core Duo T7300 2.0-GHz with 4-MB of L2 cache	446892-001
	Intel Core Duo T7100 1.8-GHz with 2-MB of L2 cache	446891-001
(11)	Top covers (include TouchPad and TouchPad cable)	
	For use with HP Compaq 6715b and 6710b computer models (includes fingerprint reader)	443823-001
	For use with HP Compaq 6715s and 6710s computer models (does not include fingerprint reader)	443822-001
(12)	PC Card/audio board assembly	
	For use with HP Compaq 6715b and 6710b computer models (includes 1394 port)	443889-001
	For use with HP Compaq 6715s and 6710s computer models	443888-001
(13)	RTC battery	449137-001
(14)	System boards	
	For use with HP Compaq 6715b computer models with WWAN capability (includes WWAN module slot)	443896-001
	For use with HP Compaq 6715b computer models without WWAN capability (does not include WWAN module slot)	443898-001
	For use with HP Compaq 6715s computer models	443897-001
	For use with HP Compaq 6710b computer models with WWAN capability (includes WWAN module slot)	446905-001
	For use with HP Compaq 6710b computer models without WWAN capability (does not include WWAN module slot)	446904-001
	For use with HP Compaq 6710s computer models	446906-001
(15)	SIM slot board —for use with HP Compaq 6715b and 6710b computer models with WWAN capability	443907-001
(16)	Speaker assembly	443821-001
(17)	Modem modules (include modem module cable)	
	For use with HP Compaq 6715 computer models and with HP Compaq 6710 computer models in all countries and regions except Japan and Asia/Pacific	441074-001
	For use with HP Compaq 6710 computer models in Japan and Asia/Pacific countries and regions	449139-001

Item	Description	Spare part number
(18)	USB/Media Card Reader board —for use with HP Compaq 6715b and 6710b computer models (includes USB/Media Card Reader board cable)	443883-001
(19)	Optical drive connector board	443820-001
(20)	Base enclosures (include 8 rubber feet, not illustrated)	
	For use with HP Compaq 6715b and 6715s computer models	443809-001
	For use with HP Compaq 6710s and 6710s computer models	443808-001
(21)	Batteries	
	6-cell, 2.55-Ah, 55-Wh, Li-ion battery	443885-001
	6-cell, 2.20-Ah, 47-Wh, Li-ion battery	443884-001
(22)	Hard drives (include hard drive bracket and connector)	
	160-GB, 5400-rpm	443920-001
	120-GB, 5400-rpm	443919-001
	80-GB, 7200-rpm	445939-001
	80-GB, 5400-rpm	443918-001
(23)	WLAN modules	
	802.11a/b/g/n Broadcom WLAN modules for use with all computer models	
	For use in Canada, the Cayman Islands, Guam, Puerto Rico, the United States, and the Virgin Islands	441530-001
	For use in Afghanistan, Albania, Algeria, Andorra, Angola, Antigua & Barbuda, Argentina, Armenia, Aruba, Australia, Austria, Azerbaijan, the Bahamas, Bahrain, Bangladesh, Barbados, Belgium, Belize, Benin, Bermuda, Bhutan, Bolivia, Bosnia & Herzegovina, Botswana, Brazil, the British Virgin Islands, Brunei, Bulgaria, Burkina Faso, Burundi, Cameroon, Cape Verde, the Central African Republic, Chad, Chile, China, Colombia, Comoros, Congo, Costa Rica, Croatia, Cyprus, the Czech Republic, Denmark, Djibouti, Dominica, the Dominican Republic, East Timor, Ecuador, Egypt, El Salvador, Equatorial Guinea, Eritrea, Estonia, Ethiopia, Fiji, Finland, France, French Guiana, Gabon, Gambia, Georgia, Germany, Ghana, Gibraltar, Greece, Grenada, Guadeloupe, Guatemala, Guinea, Guinea-Bissau, Guyana, Haiti, Honduras, Hong Kong, Hungary, Iceland, India, Ireland, Italy, the Ivory Coast, Jamaica, Jordan, Kazakhstan, Kenya, Kiribati, Kyrgyzstan, Laos, Latvia, Lebanon, Lesotho, Liberia, Liechtenstein, Lithuania, Luxembourg, Macedonia, Madagascar, Malawi, the Maldives, Mali, Malta, the Marshall Islands, Martinique, Mauritania, Mauritius, Mexico, Micronesia, Monaco, Mongolia, Montenegro, Morocco, Mozambique, Namibia, Nauru, Nepal, the Nether Antilles, the Netherlands, New Zealand, Nicaragua, Niger, Nigeria, Norway, Oman, Pakistan, Palau, Panama, Papua New Guinea, Paraguay, Peru, the Philippines, Poland, Portugal, Puerto Rico, the Republic of Moldova, Romania, Russia, Rwanda, Samoa, San Marino, Sao Tome & Principe, Saudi Arabia, Senegal, Serbia and Montenegro, the Seychelles, Sierra Leone, Singapore, Slovakia, Slovenia, the Solomon Islands, Somalia, South Africa, Spain, Sri Lanka, St. Kitts & Nevis, St. Lucia, St. Vincent & Gren, Suriname, Swaziland, Sweden, Switzerland, Taiwan, Tajikistan, Tanzania, Togo, Tonga, Trinidad & Tobago, Tunisia, Turkey, Turkmenistan, Tuvalu, Uganda, the United Arab Emirates, the United Kingdom, Uruguay, Uzbekistan, Vanuatu, Venezuela, Vietnam, Yemen, Zaire, Zambia, and Zimbabwe	441530-002
	For use in Israel and Japan	441530-291
	802.11a/b/g/n Intel WLAN module for use with HP Compaq 6710 computer models	
	For use in Antigua and Barbuda, Argentina, Aruba, the Bahamas, Barbados, Bermuda, Brunei, Canada, the Cayman Islands, Chile, Colombia, Costa Rica, the Dominican Republic,	441086-001

Item	Description	Spare part number
	Ecuador, El Salvador, Guam, Guatemala, Haiti, Honduras, Hong Kong, India, Indonesia, Malaysia, Mexico, Panama, Paraguay, Peru, Saudi Arabia, Taiwan, Uruguay, the United States, Venezuela, and Vietnam	
	For use in Austria, Azerbaijan, Bahrain, Belgium, Brazil, Bulgaria, Croatia, Cyprus, the Czech Republic, Denmark, Egypt, Estonia, Finland, France, Georgia, Germany, Greece, Hungary, Iceland, Ireland, Israel, Italy, Latvia, Lebanon, Liechtenstein, Lithuania, Luxembourg, Malta, Monaco, the Netherlands, Norway, Oman, the Philippines, Poland, Portugal, Qatar, Romania, Russia, Serbia and Montenegro, Singapore, Slovakia, Slovenia, South Africa, Spain, Sri Lanka, Sweden, Switzerland, Turkey, Ukraine, the United Kingdom, and Uzbekistan	441086-002
	For use in Australia, New Zealand, Pakistan, the People's Republic of China, and South Korea	441086-003
	For use in Japan	441086-291
	802.11a/b/g Broadcom WLAN modules for use with all computer models	
	For use in Canada, the Cayman Islands, Guam, Puerto Rico, the United States, and the Virgin Islands	441075-001
	For use in Afghanistan, Albania, Algeria, Andorra, Angola, Antigua & Barbuda, Argentina, Armenia, Aruba, Australia, Austria, Azerbaijan, the Bahamas, Bahrain, Bangladesh, Barbados, Belarus, Belgium, Belize, Benin, Bermuda, Bhutan, Bolivia, Bosnia & Herzegovina, Botswana, Brazil, the British Virgin Islands, Brunei, Bulgaria, Burkina Faso, Burundi, Cameroon, Cape Verde, the Central African Republic, Chad, Chile, China, Colombia, Comoros, Congo, Costa Rica, Croatia, Cyprus, the Czech Republic, Denmark, Djibouti, Dominica, the Dominican Republic, East Timor, Ecuador, Egypt, El Salvador, Equatorial Guinea, Eritrea, Estonia, Ethiopia, Fiji, Finland, France, French Guiana, Gabon, Gambia, Georgia, Germany, Ghana, Gibraltar, Greece, Grenada, Guadeloupe, Guatemala, Guinea, Guinea-Bissau, Guyana, Haiti, Honduras, Hong Kong, Hungary, Iceland, India, Ireland, Israel, Italy, the Ivory Coast, Jamaica, Jordan, Kazakhstan, Kenya, Kiribati, Kyrgyzstan, Laos, Latvia, Lebanon, Lesotho, Liberia, Liechtenstein, Lithuania, Luxembourg, Macedonia, Madagascar, Malawi, Malaysia, the Maldives, Mali, Malta, the Marshall Islands, Martinique, Mauritania, Mauritius, Mexico, Micronesia, Monaco, Mongolia, Montenegro, Morocco, Mozambique, Namibia, Nauru, Nepal, the Netherlands, New Zealand, Nicaragua, Niger, Nigeria, Norway, Oman, Pakistan, Palau, Panama, Papua New Guinea, Paraguay, Peru, the Philippines, Poland, Portugal, the Republic of Moldova, Romania, Russia, Rwanda, Samoa, San Marino, Sao Tome & Principe, Saudi Arabia, Senegal, Serbia and Montenegro, the Seychelles, Sierra Leone, Singapore, Slovakia, Slovenia, the Solomon Islands, Somalia, South Africa, South Korea, Spain, Sri Lanka, St. Kitts & Nevis, St. Lucia, St. Vincent & Grenadines, Suriname, Swaziland, Sweden, Switzerland, Taiwan, Tajikistan, Tanzania, Togo, Tonga, Trinidad & Tobago, Tunisia, Turkey, Turkmenistan, Tuvalu, Uganda, Ukraine, the United Arab Emirates, the United Kingdom, Uruguay, Uzbekistan, Vanuatu, Venezuela, Vietnam, Yemen, Zaire, Zambia, and Zimbabwe	441075-002
	For use in Israel and Japan	441075-291
	802.11a/b/g Intel WLAN modules for use with HP Compaq 6710 computer models	
	For use in Antigua and Barbuda, Argentina, Australia, the Bahamas, Barbados, Brunei, Canada, Chile, the Dominican Republic, Guam, Guatemala, Hong Kong, India, Indonesia, Malaysia, Mexico, New Zealand, Panama, Paraguay, Saudi Arabia, Taiwan, the United States, and Vietnam	407575-001
	For use in Aruba, Austria, Azerbaijan, Bahrain, Belgium, Bermuda, Brazil, Bulgaria, the Cayman Islands, Colombia, Croatia, Cyprus, the Czech Republic, Denmark, Egypt, El Salvador, Estonia, Finland, France, Georgia, Germany, Greece, Hungary, Iceland, Ireland, Italy, Jordan, Latvia, Lebanon, Liechtenstein, Lithuania, Luxembourg, Malta, Monaco, the Netherlands, Norway, Oman, the Philippines, Poland, Portugal, Romania, Russia, Serbia and Montenegro, Singapore, Slovakia, Slovenia, South Africa, Spain, Sri Lanka, Sweden, Switzerland, Turkey, the United Kingdom, and Uzbekistan	407575-002

Item	Description	Spare part number
	For use in Ecuador, Haiti, Honduras, Pakistan, the People's Republic of China, Peru, Qatar, South Korea, Uruguay, and Venezuela	407575-003
	For use in Japan	407575-291
	802.11a/b/g Intel WLAN modules for use with HP Compaq 6710 computer models	
	For use in Antigua & Barbuda, Argentina, Aruba, the Bahamas, Barbados, Bermuda, Brunei, Canada, the Cayman Islands, Chile, Colombia, Costa Rica, the Dominican Republic, Ecuador, El Salvador, Guam, Guatemala, Haiti, Honduras, Hong Kong, India, Indonesia, Malaysia, Mexico, Panama, Paraguay, Peru, Saudi Arabia, Taiwan, the United States, Uruguay, Venezuela, and Vietnam	441082-001
	For use in Austria, Azerbaijan, Bahrain, Belgium, Brazil, Bulgaria, Croatia, Cyprus, the Czech Republic, Denmark, Egypt, Estonia, Finland, France, Georgia, Germany, Greece, Hungary, Iceland, Ireland, Israel, Italy, Latvia, Lebanon, Liechtenstein, Lithuania, Luxembourg, Malta, Monaco, the Netherlands, Norway, Oman, the Philippines, Poland, Portugal, Qatar, Romania, Russia, Serbia and Montenegro, Singapore, Slovakia, Slovenia, South Africa, Spain, Sri Lanka, Sweden, Switzerland, Turkey, Ukraine, the United Kingdom, and Uzbekistan	441082-002
	For use in Australia, New Zealand, Pakistan, the People's Republic of China, and South Korea	441082-003
	For use in Japan	441082-291
	802.11b/g Broadcom WLAN modules for use with all computer models	
	For use in Canada, the Cayman Islands, Guam, Puerto Rico, the United States, and the U.S. Virgin Islands	441060-001
	For use in Afghanistan, Albania, Algeria, Andorra, Angola, Antigua & Barbuda, Argentina, Armenia, Aruba, Australia, Austria, Azerbaijan, the Bahamas, Bahrain, Bangladesh, Barbados, Belarus, Belgium, Belize, Benin, Bermuda, Bhutan, Bolivia, Bosnia & Herzegovina, Botswana, Brazil, the British Virgin Islands, Brunei, Bulgaria, Burkina Faso, Burundi, Cambodia, Cameroon, Cape Verde, the Central African Republic, Chad, Chile, China, Colombia, Comoros, Congo, Costa Rica, Croatia, Cyprus, the Czech Republic, Denmark, Djibouti, Dominica, the Dominican Republic, East Timor, Ecuador, Egypt, El Salvador, Equatorial Guinea, Eritrea, Estonia, Ethiopia, Fiji, Finland, France, French Guiana, Gabon, Gambia, Georgia, Germany, Ghana, Gibraltar, Greece, Grenada, Guadeloupe, Guatemala, Guinea, Guinea-Bissau, Guyana, Haiti, Honduras, Hong Kong, Hungary, Iceland, India, Indonesia, Ireland, Israel, Italy, the Ivory Coast, Jamaica, Jordan, Kazakhstan, Kenya, Kiribati, Kuwait, Kyrgyzstan, Laos, Latvia, Lebanon, Lesotho, Liberia, Liechtenstein, Lithuania, Luxembourg, Macedonia, Madagascar, Malawi, Malaysia, the Maldives, Mali, Malta, the Marshall Islands, Martinique, Mauritania, Mauritius, Mexico, Micronesia, Monaco, Mongolia, Montenegro, Morocco, Mozambique, Namibia, Nauru, Nepal, the Netherlands, the Netherlands, New Zealand, Nicaragua, Niger, Nigeria, Norway, Oman, Pakistan, Palau, Panama, Papua New Guinea, Paraguay, Peru, the Philippines, Poland, Portugal, Qatar, the Republic of Moldova, Romania, Russia, Rwanda, Samoa, San Marino, Sao Tome & Principe, Saudi Arabia, Senegal, Serbia and Montenegro, the Seychelles, Sierra Leone, Singapore, Slovakia, Slovenia, the Solomon Islands, Somalia, South Africa, South Korea, Spain, Sri Lanka, St. Kitts & Nevis, St. Lucia, St. Vincent & Gren, Suriname, Swaziland, Sweden, Switzerland, Taiwan, Tajikistan, Tanzania, Thailand, Togo, Tonga, Trinidad & Tobago, Tunisia, Turkey, Turkmenistan, Tuvalu, Uganda, Ukraine, the United Arab Emirates, the United Kingdom, Uruguay, Uzbekistan, Vanuatu, Venezuela, Vietnam, Yemen, Zaire, Zambia, and Zimbabwe	441060-002
	For use in Japan	441060-291
	802.11b/g WLAN module for use with HP Compaq 6710 computer models in Japan	409280-004
(24)	Bluetooth modules (include Bluetooth module cable)	
	For use with all computer models in all countries and regions except Japan and Asia/Pacific	398393-002
	For use with all computer models in Japan and Asia/Pacific countries and regions	450066-001

Item	Description	Spare part number
(25)	Optical drives (include bezel and optical drive bracket)	
	DVD±RW and CD-RW Super Multi Double-Layer Combo Drive with LightScribe	443903-001
	DVD±RW and CD-RW Super Multi Double-Layer Combo Drive	443904-001
	DVD/CD-RW Combo Drive	443901-001
	DVD-ROM drive	443902-001

Plastics Kit

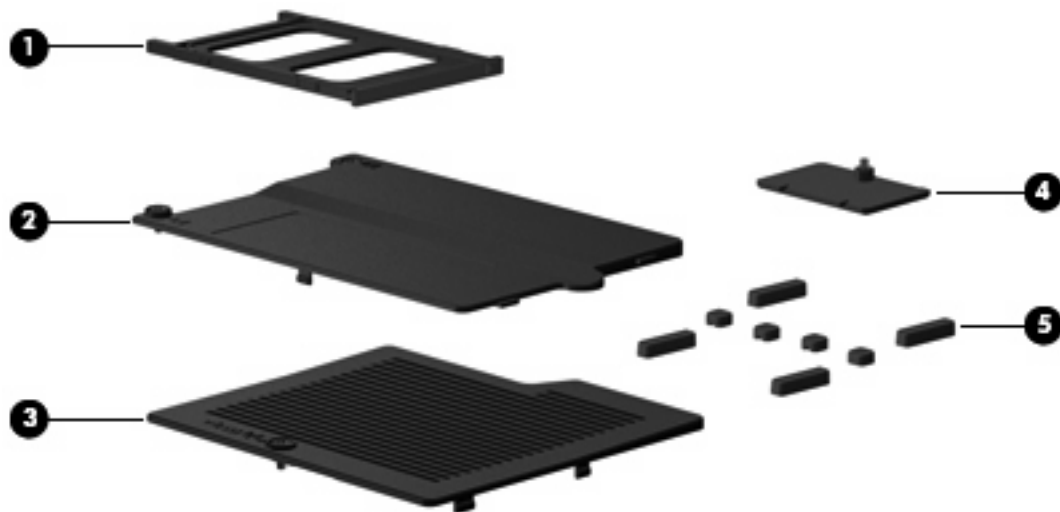

Item	Description	Spare part number
	Plastics Kit	443905-001
(1)	PC Card slot bezel	
(2)	Hard drive cover (includes 2 captive screws, secured by C-clips)	
(3)	Memory/WLAN module compartment cover (includes 1 captive screw, secured by a C-clip)	
(4)	Bluetooth module cover (includes 1 captive screw, secured by a C-clip)	
(5)	Computer feet (4 large and 4 small rubber feet)	

Cable Kit

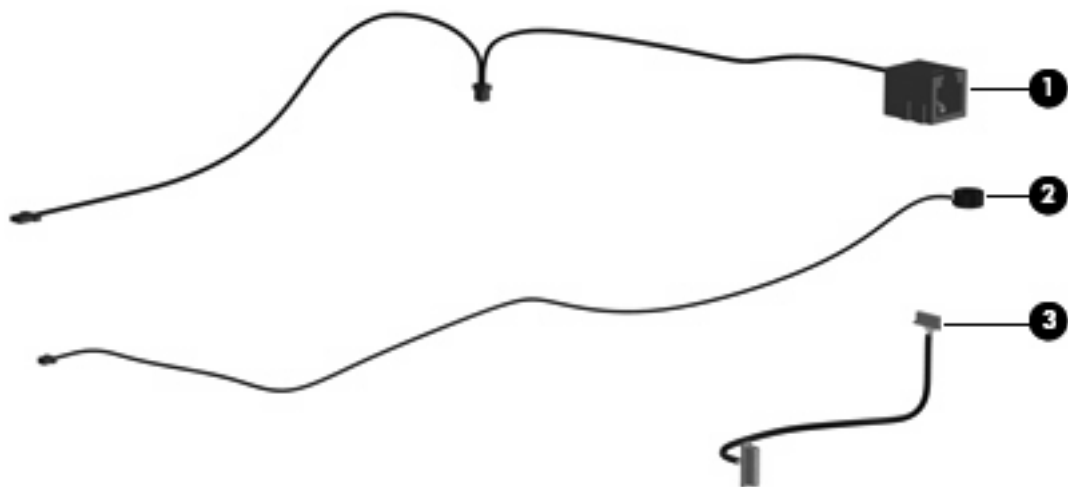

Item	Description	Spare part number
	Cable Kit	443887-001
(1)	Modem module cable (includes RJ-11 connector and cable)	
(2)	Microphone (includes receiver and cable)	
(3)	Bluetooth module cable	

Mass storage devices



Item	Description	Spare part number
(1)	Hard drives (include frame and connector)	
	160-GB, 5400-rpm	443920-001
	120-GB, 5400-rpm	443919-001
	80-GB, 7200-rpm	445939-001
	80-GB, 5400-rpm	443918-001
(2)	Optical drives (include bezel and optical drive bracket)	
	DVD±RW and CD-RW Super Multi Double-Layer Combo Drive with LightScribe	443903-001
	DVD±RW and CD-RW Super Multi Double-Layer Combo Drive	443904-001
	DVD/CD-RW Combo Drive	443901-001
	DVD-ROM drive	443902-001

Miscellaneous parts

Description	Spare part number
AC adapters	
90-watt AC adapter for use in North America	391173-001
90-watt AC adapter for use in Africa, Europe, and the Middle East	416421-021
Power cords:	
Australia	246959-011
Brazil	246959-201
Denmark	246959-081
Europe, the Middle East, and Africa	246959-021
Israel	246959-BB1
Italy	246959-061
Japan	246959-291
Korea	246959-AD1
Switzerland	246959-AG1
The United Kingdom	246959-031
The United States	246959-001
Screw Kit	443906-001
Hex HM5.0×9.0 screw lock	
Phillips PM3.0×3.0 screw	
Phillips PM2.5×13.0 captive screw	
Phillips PM2.5×8.0 captive screw	
Phillips PM2.5×7.0 captive screw	
Phillips PM2.5×7.0 screw	
Phillips PM2.5×5.0 screw	
Phillips PM2.5×3.0 screw	
Phillips PM2.0×6.0 screw	
Phillips PM2.0×5.0 captive screw	
Phillips PM2.0×3.0 screw	
Torx T8M2.5×9.0 screw	
Smart card reader module	443908-001

Sequential part number listing

Spare part number	Description
246959-001	Power cord for use in the United States
246959-011	Power cord for use in Australia
246959-021	Power cord for use in Europe, the Middle East, and Africa
246959-031	Power cord for use in the United Kingdom
246959-061	Power cord for use in Italy
246959-081	Power cord for use in Denmark
246959-201	Power cord for use in Brazil
246959-291	Power cord for use in Japan
246959-AD1	Power cord for use in Korea
246959-AG1	Power cord for use in Switzerland
246959-BB1	Power cord for use in Israel
391173-001	90-watt PFC AC adapter for use with computer models in Africa, Europe, and the Middle East
398393-002	Bluetooth module for use with all computer models in all countries and regions except Japan and Asia/Pacific (includes Bluetooth module cable)
399440-001	EVDO WWAN module
407575-001	802.11a/b/g Intel WLAN module for use with HP Compaq 6710 computer models in Antigua and Barbuda, Argentina, Australia, the Bahamas, Barbados, Brunei, Canada, Chile, the Dominican Republic, Guam, Guatemala, Hong Kong, India, Indonesia, Malaysia, Mexico, New Zealand, Panama, Paraguay, Saudi Arabia, Taiwan, the United States, and Vietnam
407575-002	802.11a/b/g Intel WLAN module for use with HP Compaq 6710 computer models in Aruba, Austria, Azerbaijan, Bahrain, Belgium, Bermuda, Brazil, Bulgaria, the Cayman Islands, Colombia, Croatia, Cyprus, the Czech Republic, Denmark, Egypt, El Salvador, Estonia, Finland, France, Georgia, Germany, Greece, Hungary, Iceland, Ireland, Italy, Jordan, Latvia, Lebanon, Liechtenstein, Lithuania, Luxembourg, Malta, Monaco, the Netherlands, Norway, Oman, the Philippines, Poland, Portugal, Romania, Russia, Serbia and Montenegro, Singapore, Slovakia, Slovenia, South Africa, Spain, Sri Lanka, Sweden, Switzerland, Turkey, the United Kingdom, and Uzbekistan
407575-003	802.11a/b/g Intel WLAN module for use with HP Compaq 6710 computer models in Ecuador, Haiti, Honduras, Pakistan, the People's Republic of China, Peru, Qatar, South Korea, Uruguay, and Venezuela
407575-291	802.11a/b/g Intel WLAN module for use with HP Compaq 6710 computer models in Japan
409280-004	802.11b/g WLAN module for use with HP Compaq 6710 computer models in Thailand
413706-001	Thermal Material Kit for use in all countries and regions except Japan and Asia/Pacific
414045-001	512-MB, 1-DIMM, PC2-5300 memory module
414046-001	1024-MB, 1-DIMM, PC2-5300 memory module
416421-021	90-watt PFC AC adapter for use with computer models in North America
417506-001	2048-MB, 1-DIMM, PC2-5300 memory module
430871-001	Mobile AMD Sempron 3400+ 1.8-GHz processor for use with HP Compaq 6715 computer models in all countries and regions except Japan and Asia/Pacific (256-KB L2 cache)

Spare part number	Description
430872-001	Mobile AMD Sempron 3500+ 1.8-GHz processor for use with HP Compaq 6715 computer models in all countries and regions except Japan and Asia/Pacific (512-KB L2 cache)
430874-001	AMD Turion TL-52 1.6-GHz processor for use with HP Compaq 6715 computer models in all countries and regions except Japan and Asia/Pacific (1-MB L2 cache)
430875-001	AMD Turion TL-56 1.8-GHz processor for use with HP Compaq 6715 computer models in all countries and regions except Japan and Asia/Pacific (1-MB L2 cache)
430876-001	AMD Turion TL-60 2.0-GHz processor for use with HP Compaq 6715 computer models in all countries and regions except Japan and Asia/Pacific (1-MB L2 cache)
441060-001	802.11b/g Broadcom WLAN module for use with all computer models only in Canada, the Cayman Islands, Guam, Puerto Rico, the United States, and the Virgin Islands
441060-002	802.11b/g Broadcom WLAN module for use with all computer models only in Afghanistan, Albania, Algeria, Andorra, Angola, Antigua & Barbuda, Argentina, Armenia, Aruba, Australia, Austria, Azerbaijan, the Bahamas, Bahrain, Bangladesh, Barbados, Belarus, Belgium, Belize, Benin, Bermuda, Bhutan, Bolivia, Bosnia & Herzegovina, Botswana, Brazil, the British Virgin Islands, Brunei, Bulgaria, Burkina Faso, Burundi, Cameroon, Cape Verde, the Central African Republic, Chad, Chile, China, Colombia, Comoros, Congo, Costa Rica, Croatia, Cyprus, the Czech Republic, Denmark, Djibouti, Dominica, the Dominican Republic, East Timor, Ecuador, Egypt, El Salvador, Equatorial Guinea, Eritrea, Estonia, Ethiopia, Fiji, Finland, France, French Guiana, Gabon, Gambia, Georgia, Germany, Ghana, Gibraltar, Greece, Grenada, Guadeloupe, Guatemala, Guinea, Guinea-Bissa, Guyana, Haiti, Honduras, Hong Kong, Hungary, Iceland, India, Ireland, Israel, Italy, the Ivory Coast, Jamaica, Jordan, Kazakhstan, Kenya, Kiribati, Kyrgyzstan, Laos, Latvia, Lebanon, Lesotho, Liberia, Liechtenstein, Lithuania, Luxembourg, Macedonia, Madagascar, Malawi, Malaysia, the Maldives, Mali, Malta, the Marshall Islands, Martinique, Mauritania, Mauritius, Mexico, Micronesia, Monaco, Mongolia, Montenegro, Morocco, Mozambique, Namibia, Nauru, Nepal, the Nether Antilles, the Netherlands, New Zealand, Nicaragua, Niger, Nigeria, Norway, Oman, Pakistan, Palau, Panama, Papua New Guinea, Paraguay, Peru, the Philippines, Poland, Portugal, the Republic of Moldova, Romania, Russia, Rwanda, Samoa, San Marino, Sao Tome & Principe, Saudi Arabia, Senegal, Serbia and Montenegro, the Seychelles, Sierra Leone, Singapore, Slovakia, Slovenia, the Solomon Islands, Somalia, South Africa, South Korea, Spain, Sri Lanka, St. Kitts & Nevis, St. Lucia, St. Vincent & Gren, Suriname, Swaziland, Sweden, Switzerland, Taiwan, Tajikistan, Tanzania, Togo, Tonga, Trinidad & Tobago, Tunisia, Turkey, Turkmenistan, Tuvalu, Uganda, Ukraine, the United Arab Emirates, the United Kingdom, Uruguay, Uzbekistan, Vanuatu, Venezuela, Vietnam, Yemen, Zaire, Zambia, and Zimbabwe
441060-291	802.11b/g Broadcom WLAN module for use with all computer models only in Japan
441074-001	For use with HP Compaq 6715 computer models and with HP Compaq 6710 computer models in all countries and regions except Japan and Asia/Pacific
441075-001	802.11a/b/g Broadcom WLAN module for use with all computer models only in Canada, the Cayman Islands, Guam, Puerto Rico, the United States, and the Virgin Islands
441075-002	802.11a/b/g Broadcom WLAN module for use with all computer models only in Afghanistan, Albania, Algeria, Andorra, Angola, Antigua & Barbuda, Argentina, Armenia, Aruba, Australia, Austria, Azerbaijan, the Bahamas, Bahrain, Bangladesh, Barbados, Belarus, Belgium, Belize, Benin, Bermuda, Bhutan, Bolivia, Bosnia & Herzegovina, Botswana, Brazil, the British Virgin Islands, Brunei, Bulgaria, Burkina Faso, Burundi, Cameroon, Cape Verde, the Central African Republic, Chad, Chile, China, Colombia, Comoros, Congo, Costa Rica, Croatia, Cyprus, the Czech Republic, Denmark, Djibouti, Dominica, the Dominican Republic, East Timor, Ecuador, Egypt, El Salvador, Equatorial Guinea, Eritrea, Estonia, Ethiopia, Fiji, Finland, France, French Guiana, Gabon, Gambia, Georgia, Germany, Ghana, Gibraltar, Greece, Grenada, Guadeloupe, Guatemala, Guinea, Guinea-Bissa, Guyana, Haiti, Honduras, Hong Kong, Hungary, Iceland, India, Ireland, Israel, Italy, the Ivory Coast, Jamaica, Jordan, Kazakhstan, Kenya, Kiribati, Kyrgyzstan, Laos, Latvia, Lebanon, Lesotho, Liberia, Liechtenstein, Lithuania, Luxembourg, Macedonia, Madagascar, Malawi, Malaysia, the Maldives, Mali, Malta, the Marshall Islands, Martinique, Mauritania, Mauritius, Mexico, Micronesia, Monaco, Mongolia, Montenegro, Morocco, Mozambique, Namibia, Nauru, Nepal, the Nether Antilles, the Netherlands, New Zealand, Nicaragua, Niger, Nigeria, Norway, Oman, Pakistan, Palau, Panama, Papua New Guinea, Paraguay, Peru, the Philippines, Poland, Portugal, the Republic of Moldova, Romania, Russia, Rwanda, Samoa, San Marino, Sao Tome & Principe, Saudi Arabia, Senegal, Serbia and Montenegro, the Seychelles, Sierra Leone, Singapore, Slovakia, Slovenia, the Solomon Islands, Somalia, South Africa, South Korea, Spain, Sri Lanka, St. Kitts & Nevis, St. Lucia, St. Vincent & Gren, Suriname, Swaziland, Sweden, Switzerland, Taiwan, Tajikistan, Tanzania, Togo,

Spare part number	Description
	Tonga, Trinidad & Tobago, Tunisia, Turkey, Turkmenistan, Tuvalu, Uganda, Ukraine, the United Arab Emirates, the United Kingdom, Uruguay, Uzbekistan, Vanuatu, Venezuela, Vietnam, Yemen, Zaire, Zambia, and Zimbabwe
441075-291	802.11a/b/g Broadcom WLAN module for use with all computer models only in Israel and Japan
441082-001	802.11a/b/g Intel WLAN module for use with HP Compaq 6710 computer models in Antigua & Barbuda, Argentina, Aruba, the Bahamas, Barbados, Bermuda, Brunei, Canada, the Cayman Islands, Chile, Colombia, Costa Rica, the Dominican Republic, Ecuador, El Salvador, Guam, Guatemala, Haiti, Honduras, Hong Kong, India, Indonesia, Malaysia, Mexico, Panama, Paraguay, Peru, Saudi Arabia, Taiwan, the United States, Uruguay, Venezuela, Vietnam
441082-002	802.11a/b/g Intel WLAN module for use with HP Compaq 6710 computer models in Austria, Azerbaijan, Bahrain, Belgium, Brazil, Bulgaria, Croatia, Cyprus, the Czech Republic, Denmark, Egypt, Estonia, Finland, France, Georgia, Germany, Greece, Hungary, Iceland, Ireland, Israel, Italy, Latvia, Lebanon, Liechtenstein, Lithuania, Luxembourg, Malta, Monaco, the Netherlands, Norway, Oman, the Philippines, Poland, Portugal, Qatar, Romania, Russia, Serbia and Montenegro, Singapore, Slovakia, Slovenia, South Africa, Spain, Sri Lanka, Sweden, Switzerland, Turkey, Ukraine, the United Kingdom, and Uzbekistan
441082-003	802.11a/b/g Intel WLAN module for use with HP Compaq 6710 computer models in Australia, New Zealand, Pakistan, the People's Republic of China, and South Korea
441082-291	802.11a/b/g Intel WLAN module for use with HP Compaq 6710 computer models in Japan
441086-001	802.11a/b/g/n Intel WLAN module for use with HP Compaq 6710 computer models in Antigua and Barbuda, Argentina, Aruba, the Bahamas, Barbados, Bermuda, Brunei, Canada, the Cayman Islands, Chile, Colombia, Costa Rica, the Dominican Republic, Ecuador, El Salvador, Guam, Guatemala, Haiti, Honduras, Hong Kong, India, Indonesia, Malaysia, Mexico, Panama, Paraguay, Peru, Saudi Arabia, Taiwan, Uruguay, the United States, Venezuela, and Vietnam
441086-002	802.11a/b/g/n Intel WLAN module for use with HP Compaq 6710 computer models in Austria, Azerbaijan, Bahrain, Belgium, Brazil, Bulgaria, Croatia, Cyprus, the Czech Republic, Denmark, Egypt, Estonia, Finland, France, Georgia, Germany, Greece, Hungary, Iceland, Ireland, Israel, Italy, Latvia, Lebanon, Liechtenstein, Lithuania, Luxembourg, Malta, Monaco, the Netherlands, Norway, Oman, the Philippines, Poland, Portugal, Qatar, Romania, Russia, Serbia and Montenegro, Singapore, Slovakia, Slovenia, South Africa, Spain, Sri Lanka, Sweden, Switzerland, Turkey, Ukraine, the United Kingdom, and Uzbekistan
441086-003	802.11a/b/g/n Intel WLAN module for use in with HP Compaq 6710 computer models in Australia, New Zealand, Pakistan, the People's Republic of China, and South Korea
441086-291	802.11a/b/g/n Intel WLAN module for use with HP Compaq 6710 computer models in Japan
441530-001	802.11a/b/g/n Broadcom WLAN module for use with all computer models only in Canada, the Cayman Islands, Guam, Puerto Rico, the United States, and the Virgin Islands
441530-002	802.11a/b/g/n Broadcom WLAN module for use with all computer models only in Afghanistan, Albania, Algeria, Andorra, Angola, Antigua & Barbuda, Argentina, Armenia, Aruba, Australia, Austria, Azerbaijan, the Bahamas, Bahrain, Bangladesh, Barbados, Belgium, Belize, Benin, Bermuda, Bhutan, Bolivia, Bosnia & Herzegovina, Botswana, Brazil, the British Virgin Islands, Brunei, Bulgaria, Burkina Faso, Burundi, Cameroon, Cape Verde, the Central African Republic, Chad, Chile, China, Colombia, Comoros, Congo, Costa Rica, Croatia, Cyprus, the Czech Republic, Denmark, Djibouti, Dominica, the Dominican Republic, East Timor, Ecuador, Egypt, El Salvador, Equatorial Guinea, Eritrea, Estonia, Ethiopia, Fiji, Finland, France, French Guiana, Gabon, Gambia, Georgia, Germany, Ghana, Gibraltar, Greece, Grenada, Guadeloupe, Guatemala, Guinea, Guinea-Bissa, Guyana, Haiti, Honduras, Hong Kong, Hungary, Iceland, India, Ireland, Italy, the Ivory Coast, Jamaica, Jordan, Kazakhstan, Kenya, Kiribati, Kyrgyzstan, Laos, Latvia, Lebanon, Lesotho, Liberia, Liechtenstein, Lithuania, Luxembourg, Macedonia, Madagascar, Malawi, the Maldives, Mali, Malta, the Marshall Islands, Martinique, Mauritania, Mauritius, Mexico, Micronesia, Monaco, Mongolia, Montenegro, Morocco, Mozambique, Namibia, Nauru, Nepal, the Nether Antilles, the Netherlands, New Zealand, Nicaragua, Niger, Nigeria, Norway, Oman, Pakistan, Palau, Panama, Papua New Guinea, Paraguay, Peru, the Philippines, Poland, Portugal, Puerto Rico, the Republic of Moldova, Romania, Russia, Rwanda, Samoa, San Marino, Sao Tome & Principe Saudi Arabia, Senegal, Serbia and Montenegro, the Seychelles, Sierra Leone, Singapore, Slovakia, Slovenia, the Solomon Islands, Somalia, South Africa, Spain, Sri Lanka, St. Kitts & Nevis, St. Lucia, St. Vincent & Gren, Suriname, Swaziland, Sweden, Switzerland, Taiwan, Tajikistan, Tanzania, Togo, Tonga,

Spare part number	Description
	Trinidad & Tobago, Tunisia, Turkey, Turkmenistan, Tuvalu, Uganda, the United Arab Emirates, the United Kingdom, Uruguay, Uzbekistan, Vanuatu, Venezuela, Vietnam, Yemen, Zaire, Zambia, and Zimbabwe
441530-291	802.11a/b/g/n Broadcom WLAN module for use with all computer models only in Israel and Japan
443808-001	Base enclosure for use with HP Compaq 6715b and 6710s computer models (includes 8 rubber feet)
443809-001	Base enclosure for use with HP Compaq 6715s and 6710s computer models (includes 8 rubber feet)
443811-001	Keyboard for use in the United States
443811-031	Keyboard for use in the United Kingdom
443811-041	Keyboard for use in Germany
443811-051	Keyboard for use in France
443811-061	Keyboard for use in Italy
443811-071	Keyboard for use in Spain
443811-081	Keyboard for use in Denmark
443811-091	Keyboard for use in Norway
443811-121	Keyboard for use in French Canada
443811-131	Keyboard for use in Portugal
443811-141	Keyboard for use in Turkey
443811-161	Keyboard for use in Latin America
443811-171	Keyboard for use in Saudi Arabia
443811-181	Keyboard for use in Belgium
443811-201	Keyboard for use in Brazil
443811-211	Keyboard for use in Hungary
443811-221	Keyboard for use in the Czech Republic
443811-231	Keyboard for use in Slovakia
443811-251	Keyboard for use in Russia
443811-281	Keyboard for use in Thailand
443811-291	Keyboard for use in Japan
443811-AB1	Keyboard for use in Taiwan
443811-AD1	Keyboard for use in Korea
443811-B31	Keyboard for use internationally
443811-B71	Keyboard for use in Sweden
443811-BA1	Keyboard for use in Slovenia
443811-BB1	Keyboard for use in Israel
443811-BG1	Keyboard for use in Switzerland
443811-DD1	Keyboard for use in Iceland

Spare part number	Description
443811-DJ1	Keyboard for use in Greece
443812-001	15.4-inch WXGA, BrightView display assembly for use with HP Compaq 6715s and 6710s computer models
443813-001	15.4-inch WSXGA+ display assembly for use with HP Compaq 6715b and 6710b computer models without WWAN capability
443814-001	15.4-inch WSXGA+ display assembly for use with HP Compaq 6715b and 6710b computer models with WWAN capability
443815-001	15.4-inch WSXGA+ display assembly for use with HP Compaq 6715b and 6710b computer models without WWAN capability
443816-001	15.4-inch WXGA, BrightView display assembly for use with HP Compaq 6715b and 6710b computer models without WWAN capability
443817-001	15.4-inch WXGA, BrightView display assembly for use with HP Compaq 6715b and 6710b computer models with WWAN capability
443818-001	15.4-inch WSXGA+ display assembly for use with HP Compaq 6715s and 6710s computer models
443819-001	15.4-inch WXGA display assembly for use with HP Compaq 6715s and 6710s computer models
443820-001	Optical drive connector board
443821-001	Speaker assembly
443822-001	Top cover for use with HP Compaq 6715b and 6710b computer models (includes TouchPad, TouchPad cable, and fingerprint reader)
443823-001	Top cover for use with HP Compaq 6715s and 6710s computer models (includes TouchPad and TouchPad cable)
443883-001	USB/Media Card Reader board—for use with HP Compaq 6715b and 6710b computer models (includes USB/Media Card Reader board cable)
443884-001	6-cell, 2.20-Ah, 47-Wh battery
443885-001	6-cell, 2.55-Ah, 55-Wh battery
443887-001	Cable Kit
443888-001	PC Card/audio board assembly for use with HP Compaq 6715s and 6710s computer models
443889-001	PC Card/audio board assembly for use with HP Compaq 6715b and 6710b computer models (includes 1394 port)
443890-001	AMD Turion TL-52 1.6-GHz processor for use with HP Compaq 6715 computer models only in Japan and Asia/Pacific countries and regions (1-MB L2 cache)
443891-001	AMD Turion TL-56 1.8-GHz processor for use only with HP Compaq 6715 computer models only in Japan and Asia/Pacific countries and regions (1-MB L2 cache)
443892-001	AMD Turion TL-60 2.0-GHz processor for use only with HP Compaq 6715 computer models only in Japan and Asia/Pacific countries and regions (1-MB L2 cache)
443896-001	System board for use with HP Compaq 6715b computer models with WWAN capability (includes WWAN module slot)
443897-001	System board for use with HP Compaq 6715s computer models
443898-001	System board for use with HP Compaq 6715b computer models without WWAN capability (does not include WWAN module slot)
443901-001	DVD/CD-RW Combo Drive
443902-001	DVD-ROM drive

Spare part number	Description
443903-001	DVD±RW and CD-RW Super Multi Double-Layer Combo Drive with LightScribe
443904-001	DVD±RW and CD-RW Super Multi Double-Layer Combo Drive
443905-001	Plastics Kit
443906-001	Screw Kit
443907-001	SIM slot board (for use with HP Compaq 6715b and 6710b computer models)
443908-001	Smart card reader module
443910-001	Switch cover for use with HP Compaq 6715s and 6710s computer models (includes power button board and power button board cable, but does not include LED board or LED board cable)
443911-001	Switch cover for use with HP Compaq 6715b and 6710b computer models (includes power button board and power button board cable and LED board and LED board cable)
443912-001	Heat sink for use with HP Compaq 6715 computer models (includes thermal material)
443913-001	AMD Turion TL-64 2.2-GHz processor for use with HP Compaq 6715 computer models in all countries and regions except Japan and Asia/Pacific (1-MB L2 cache)
443914-001	Mobile AMD Sempron 3400+ 1.8-GHz processor for use with HP Compaq 6715 computer models only in Japan and Asia/Pacific countries and regions (256-KB L2 cache)
443915-001	Mobile AMD Sempron 3500+ 1.8-GHz processor for use with HP Compaq 6715 computer models only in Japan and Asia/Pacific countries and regions (512-KB L2 cache)
443916-001	Mobile AMD Sempron 3600+ 2.0-GHz processor for use with HP Compaq 6715 computer models in all countries and regions except Japan and Asia/Pacific (256-KB L2 cache)
443917-001	Fan
443918-001	80-GB, 5400-rpm hard drive
443919-001	120-GB, 5400-rpm hard drive
443920-001	160-GB, 5400-rpm hard drive
445853-001	Thermal Material Kit for use in Japan and Asia/Pacific countries and regions
445939-001	80-GB, 7200-rpm hard drive
446045-001	AMD Turion MK-38 2.2-GHz processor for use with HP Compaq 6715 computer models in all countries and regions except Japan and Asia/Pacific (512-KB L2 cache)
446870-001	Display inverter (includes 2-sided tape)
446871-001	Display bezel
446882-001	Display left and right hinges
446883-001	Display enclosure for use with HP Compaq 6715b and 6710b computer models
446891-001	Intel Core Duo T7700 2.4-GHz processor with 4-MB L2 cache
446892-001	Intel Core Duo T7500 2.2-GHz processor with 4-MB L2 cache
446893-001	Intel Core Duo T7300 2.0-GHz processor with 4-MB L2 cache
446894-001	Intel Core Duo T7100 1.8-GHz processor with 2-MB L2 cache
446896-001	15.4-inch, WXGA display panel for use with HP Compaq 6710b computer models without WWAN capability

Spare part number	Description
446897-001	15.4-inch, WSXGA+ display panel for use with HP Compaq 6710b computer models without WWAN capability
446898-001	15.4-inch, WXGA, BrightView display panel for use with HP Compaq 6710b computer models without WWAN capability
446899-001	15.4-inch, WXGA display panel for use with HP Compaq 6710b computer models with WWAN capability
446900-001	15.4-inch, WSXGA+ display panel for use with HP Compaq 6710b computer models with WWAN capability
446901-001	15.4-inch, WXGA display panel for use with HP Compaq 6710s computer models
446902-001	15.4-inch, WSXGA+ display panel for use with HP Compaq 6710s computer models
446903-001	15.4-inch, WXGA, BrightView display panel for use with HP Compaq 6710s computer models
446904-001	System board for use with HP Compaq 6710b computer models without WWAN capability (does not include WWAN module slot)
446905-001	System board for use with HP Compaq 6710b computer models with WWAN capability (includes WWAN module slot)
446906-001	System board for use with HP Compaq 6710s computer models
446920-001	Heat sink for use with HP Compaq 6710 computer models (includes thermal material)
448672-002	Vodafone HSPDA WWAN module
448673-002	Cingular HSPDA WWAN module
449137-001	RTC battery
449139-001	Modem module for use with HP Compaq 6710 computer models in Japan and Asia/Pacific countries and regions (includes modem module cable)
450066-001	Bluetooth module for use with all computer models in all countries and regions except Japan and Asia/Pacific (includes Bluetooth module cable)
450612-001	Display enclosure for use with HP Compaq 6715s and 6710s computer models
450939-001	Mobile AMD Sempron 3800+ 2.2-GHz processor for use in all countries and regions except Japan and Asia/Pacific (256-KB L2 cache)
450940-001	AMD Turion TL-50 1.6-GHz processor for use in all countries and regions except Japan and Asia/Pacific (1-MB L2 cache)

4 Removal and replacement procedures

Preliminary replacement requirements

Tools required

You will need the following tools to complete the removal and replacement procedures:

- Flat-bladed screwdriver
- Hex 5.0-mm nutdriver
- Magnetic screwdriver
- Phillips P0 and P1 screwdrivers
- Torx T8 screwdriver

Service considerations

The following sections include some of the considerations that you must keep in mind during disassembly and assembly procedures.

 **NOTE:** As you remove each subassembly from the computer, place the subassembly (and all accompanying screws) away from the work area to prevent damage.

Plastic parts

Using excessive force during disassembly and reassembly can damage plastic parts. Use care when handling the plastic parts. Apply pressure only at the points designated in the maintenance instructions.

Cables and connectors

-
- △ **CAUTION:** When servicing the computer, be sure that cables are placed in their proper locations during the reassembly process. Improper cable placement can damage the computer.
-

Cables must be handled with extreme care to avoid damage. Apply only the tension required to unseat or seat the cables during removal and insertion. Handle cables by the connector whenever possible. In all cases, avoid bending, twisting, or tearing cables. Be sure that cables are routed in such a way that they cannot be caught or snagged by parts being removed or replaced. Handle flex cables with extreme care; these cables tear easily.

Drive handling

-
- △ **CAUTION:** Drives are fragile components that must be handled with care. To prevent damage to the computer, damage to a drive, or loss of information, observe these precautions:
-

Before removing or inserting a hard drive, shut down the computer. If you are unsure whether the computer is off or in Hibernation, turn the computer on, and then shut it down through the operating system.

Before handling a drive, be sure that you are discharged of static electricity. While handling a drive, avoid touching the connector.

Before removing a diskette drive or optical drive, be sure that a diskette or disc is not in the drive and be sure that the optical drive tray is closed.

Handle drives on surfaces covered with at least one inch of shock-proof foam.

Avoid dropping drives from any height onto any surface.

After removing a hard drive, an optical drive, or a diskette drive, place it in a static-proof bag.

Avoid exposing a hard drive to products that have magnetic fields, such as monitors or speakers.

Avoid exposing a drive to temperature extremes or liquids.

If a drive must be mailed, place the drive in a bubble pack mailer or other suitable form of protective packaging and label the package "FRAGILE."

Grounding guidelines

Electrostatic discharge damage

Electronic components are sensitive to electrostatic discharge (ESD). Circuitry design and structure determine the degree of sensitivity. Networks built into many integrated circuits provide some protection, but in many cases, ESD contains enough power to alter device parameters or melt silicon junctions.

A discharge of static electricity from a finger or other conductor can destroy static-sensitive devices or microcircuitry. Even if the spark is neither felt nor heard, damage may have occurred.

An electronic device exposed to ESD may not be affected at all and can work perfectly throughout a normal cycle. Or the device may function normally for a while, then degrade in the internal layers, reducing its life expectancy.

△ **CAUTION:** To prevent damage to the computer when you are removing or installing internal components, observe these precautions:

Keep components in their electrostatic-safe containers until you are ready to install them.

Use nonmagnetic tools.

Before touching an electronic component, discharge static electricity by using the guidelines described in this section.

Avoid touching pins, leads, and circuitry. Handle electronic components as little as possible.

If you remove a component, place it in an electrostatic-safe container.

The following table shows how humidity affects the electrostatic voltage levels generated by different activities.

△ **CAUTION:** A product can be degraded by as little as 700 V.

Typical electrostatic voltage levels			
Event	Relative humidity		
	10%	40%	55%
Walking across carpet	35,000 V	15,000 V	7,500 V
Walking across vinyl floor	12,000 V	5,000 V	3,000 V
Motions of bench worker	6,000 v	800 V	400 V
Removing DIPS from plastic tube	2,000 V	700 V	400 V
Removing DIPS from vinyl tray	11,500 V	4,000 V	2,000 V
Removing DIPS from Styrofoam	14,500 V	5,000 V	3,500 V
Removing bubble pack from PCB	26,500 V	20,000 V	7,000 V
Packing PCBs in foam-lined box	21,000 V	11,000 V	5,000 V

Packaging and transporting guidelines

Follow these grounding guidelines when packaging and transporting equipment:

- To avoid hand contact, transport products in static-safe tubes, bags, or boxes.
- Protect ESD-sensitive parts and assemblies with conductive or approved containers or packaging.
- Keep ESD-sensitive parts in their containers until the parts arrive at static-free workstations.
- Place items on a grounded surface before removing items from their containers.
- Always be properly grounded when touching a component or assembly.
- Store reusable ESD-sensitive parts from assemblies in protective packaging or nonconductive foam.
- Use transporters and conveyors made of antistatic belts and roller bushings. Be sure that mechanized equipment used for moving materials is wired to ground and that proper materials are selected to avoid static charging. When grounding is not possible, use an ionizer to dissipate electric charges.

Workstation guidelines

Follow these grounding workstation guidelines:

- Cover the workstation with approved static-shielding material.
- Use a wrist strap connected to a properly grounded work surface and use properly grounded tools and equipment.
- Use conductive field service tools, such as cutters, screwdrivers, and vacuums.
- When fixtures must directly contact dissipative surfaces, use fixtures made only of static-safe materials.
- Keep the work area free of nonconductive materials, such as ordinary plastic assembly aids and Styrofoam.
- Handle ESD-sensitive components, parts, and assemblies by the case or PCM laminate. Handle these items only at static-free workstations.
- Avoid contact with pins, leads, or circuitry.
- Turn off power and input signals before inserting or removing connectors or test equipment.

Equipment guidelines

Grounding equipment must include either a wrist strap or a foot strap at a grounded workstation.

- When seated, wear a wrist strap connected to a grounded system. Wrist straps are flexible straps with a minimum of one megohm $\pm 10\%$ resistance in the ground cords. To provide proper ground, wear a strap snugly against the skin at all times. On grounded mats with banana-plug connectors, use alligator clips to connect a wrist strap.
- When standing, use foot straps and a grounded floor mat. Foot straps (heel, toe, or boot straps) can be used at standing workstations and are compatible with most types of shoes or boots. On conductive floors or dissipative floor mats, use foot straps on both feet with a minimum of one megohm resistance between the operator and ground. To be effective, the conductive strips must be worn in contact with the skin.

The following grounding equipment is recommended to prevent electrostatic damage:

- Antistatic tape
- Antistatic smocks, aprons, and sleeve protectors
- Conductive bins and other assembly or soldering aids
- Nonconductive foam
- Conductive tabletop workstations with ground cords of one megohm resistance
- Static-dissipative tables or floor mats with hard ties to the ground
- Field service kits
- Static awareness labels
- Material-handling packages
- Nonconductive plastic bags, tubes, or boxes
- Metal tote boxes
- Electrostatic voltage levels and protective materials

The following table lists the shielding protection provided by antistatic bags and floor mats.

Material	Use	Voltage protection level
Antistatic plastic	Bags	1,500 V
Carbon-loaded plastic	Floor mats	7,500 V
Metallized laminate	Floor mats	5,000 V

Unknown user password

If the computer you are servicing has an unknown user password, follow these steps to clear the password:

 **NOTE:** These steps also clear CMOS.

1. Shut down the computer. If you are unsure whether the computer is off or in Hibernation, turn the computer on, and then shut it down through the operating system.
2. Disconnect all external devices connected to the computer.
3. Disconnect the power from the computer by first unplugging the power cord from the AC outlet and then unplugging the AC adapter from the computer.
4. Remove the battery (see [Battery on page 48](#)).
5. Remove the real-time clock (RTC) battery (see [RTC battery on page 67](#)).
6. Wait approximately 5 minutes.
7. Replace the RTC battery and reassemble the computer.
8. Connect AC power to the computer. Do not reinsert any batteries at this time.
9. Turn on the computer.

All passwords and all CMOS settings have been cleared.

Component replacement procedures

This chapter provides removal and replacement procedures.

There are as many as 81 screws and screw locks, in 16 different sizes, that must be removed, replaced, or loosened when servicing the computer. Make special note of each screw and screw lock size and location during removal and replacement.

Serial number

Report the computer serial number to HP when requesting information or ordering spare parts. The serial number is located on the bottom of the computer.

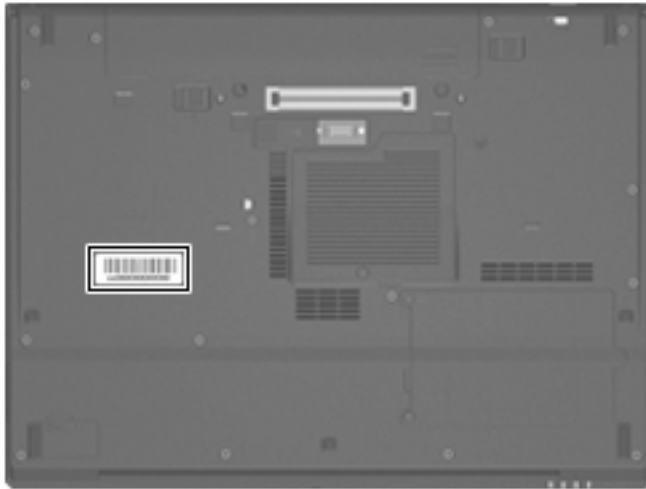

Battery

Description	Spare part number
6-cell, 2.55-Ah, 55-Wh, Li-ion battery	443885-001
6-cell, 2.20-Ah, 47-Wh, Li-ion battery	443884-001

Before disassembling the computer, follow these steps:

1. Shut down the computer. If you are unsure whether the computer is off or in Hibernation, turn the computer on, and then shut it down through the operating system.
2. Disconnect all external devices connected to the computer.
3. Disconnect the power from the computer by first unplugging the power cord from the AC outlet and then unplugging the AC adapter from the computer.

Remove the battery:

1. Turn the computer upside down on a flat surface, with the battery bay toward you.
2. Slide the release latches **(1)** to release the battery.
3. Remove the battery **(2)**.

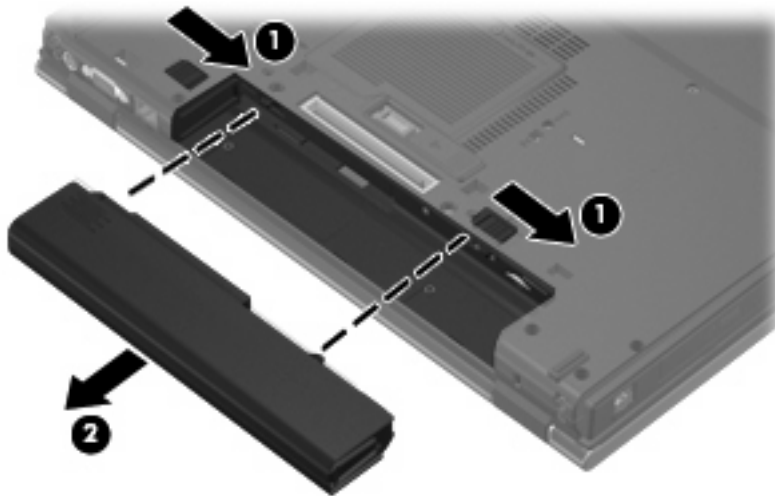

Install the battery by inserting it into the battery bay until you hear a click.

SIM

 **NOTE:** This section applies only to computer models with WWAN capability.

NOTE: If there is a SIM inserted in the SIM slot, remove it before disassembling the computer. Be sure the SIM is reinserted in the SIM slot after reassembling the computer.

Before removing the SIM, follow these steps:

1. Shut down the computer. If you are unsure whether the computer is off or in Hibernation, turn the computer on, and then shut it down through the operating system.
2. Disconnect all external devices connected to the computer.
3. Disconnect the power from the computer by first unplugging the power cord from the AC outlet and then unplugging the AC adapter from the computer.
4. Remove the battery (see [Battery on page 48](#)).

Remove the SIM:

1. Press in on the SIM **(1)**. (The module is partially ejected from the SIM slot.)
2. Remove the SIM **(2)** from the SIM slot.

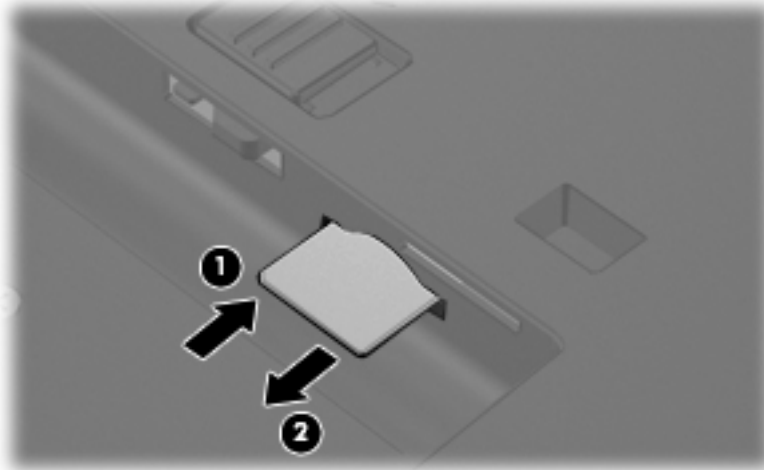

Reverse this procedure to install the SIM.

Display inverter

 **NOTE:** If it has been determined that the display inverter is the component that must be replaced to complete the computer repair, the display assembly does not have to be removed. Follow the procedures in this section to replace the display inverter. For information on replacing the display assembly and display hinges, see [Display assembly on page 76](#).

Description	Spare part number
Display inverter (includes 2-sided tape)	446870-001

Before removing the display inverter, follow these steps:

1. Shut down the computer. If you are unsure whether the computer is off or in Hibernation, turn the computer on, and then shut it down through the operating system.
2. Disconnect all external devices connected to the computer.
3. Disconnect the power from the computer by first unplugging the power cord from the AC outlet and then unplugging the AC adapter from the computer.
4. Remove the battery (see [Battery on page 48](#)).

Remove the display inverter:

1. Turn the computer right-side up, with the front toward you.
2. Open the computer as far as it will open.
3. Remove the two rubber screw covers **(1)** on the bottom edge of the display bezel.
4. Remove the two Torx T8M2.5×7.0 screws **(2)** that secure the bottom edge of the display bezel to the display enclosure.

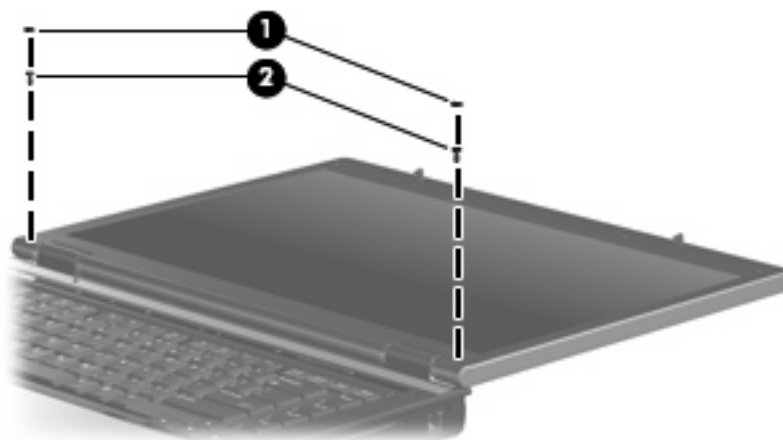

5. Flex the inside edges of the left and right sides **(1)** and the bottom edge **(2)** of the display bezel until the bezel disengages from the display enclosure.

6. Release the bottom edge of the display bezel **(3)** from the display assembly.

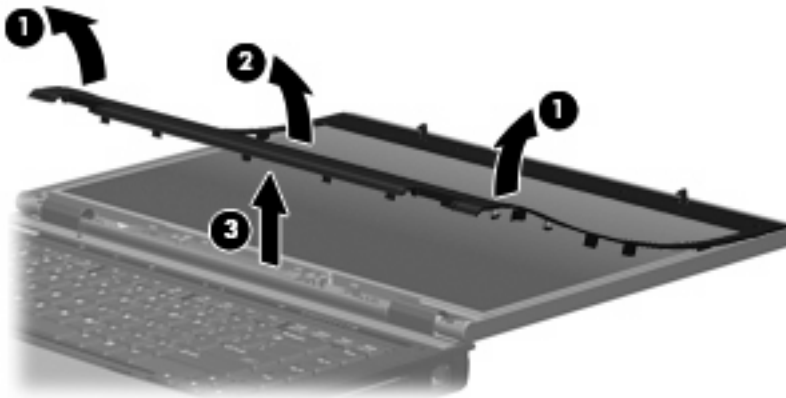

7. Release the inverter **(1)** from the display enclosure as far as the display panel cable and backlight cable allow.
8. Disconnect the display panel cable **(2)** and the backlight cable **(3)** from the display inverter.

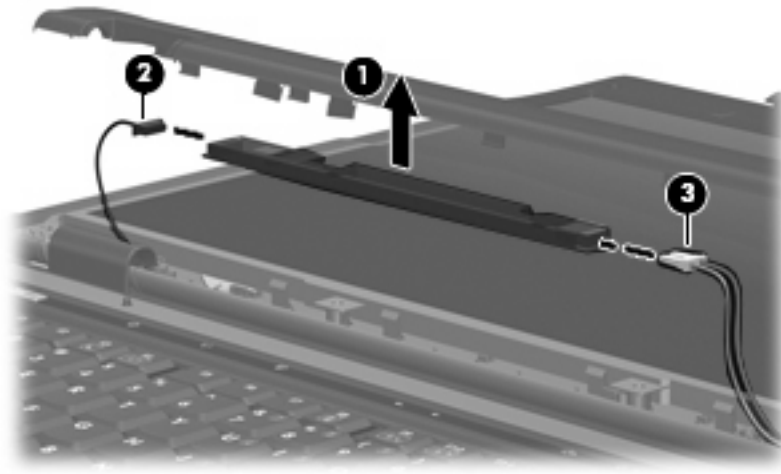

9. Remove the display inverter.

Reverse this procedure to install the display inverter.

Hard drive

Description	Spare part number
160-GB, 5400-rpm hard drive	443920-001
120-GB, 5400-rpm hard drive	443919-001
80-GB, 7200-rpm hard drive	445939-001
80-GB, 5400-rpm hard drive	443918-001

Before disassembling the computer, follow these steps:

1. Shut down the computer. If you are unsure whether the computer is off or in Hibernation, turn the computer on, and then shut it down through the operating system.
2. Disconnect all external devices connected to the computer.
3. Disconnect the power from the computer by first unplugging the power cord from the AC outlet and then unplugging the AC adapter from the computer.
4. Remove the battery (see [Battery on page 48](#)).

Remove the hard drive:

1. Position the computer with the front toward you.
2. Loosen the two Phillips PM2.0×5.0 screws **(1)** that secure the hard drive cover to the computer.
3. Lift the left side of the hard drive cover **(2)**, swing it to right, and remove the cover.

 **NOTE:** The hard drive cover is included in the Plastics Kit, spare part number 443905-001.

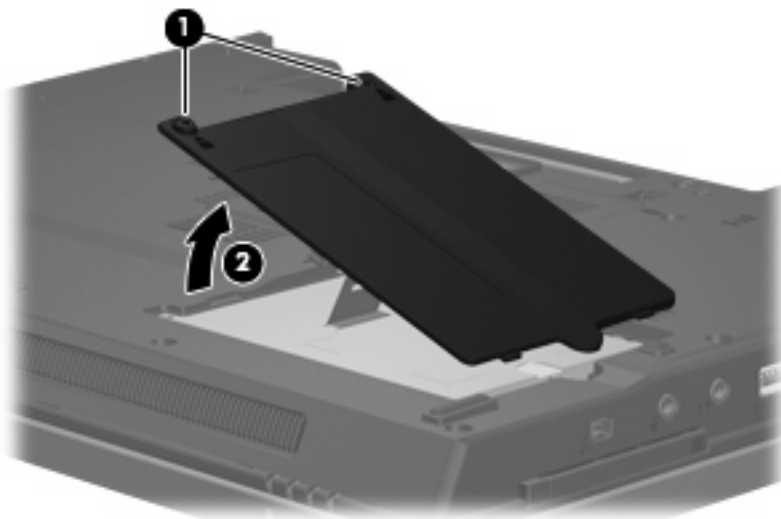

4. Loosen the Phillips PM2.5×13.0 hard drive retention screw **(1)** that secures the hard drive to the computer.
5. Grasp the Mylar tab **(2)** on the hard drive and slide the hard drive **(3)** to the right to disconnect it from the system board.

6. Remove the hard drive **(4)** from the hard drive bay.

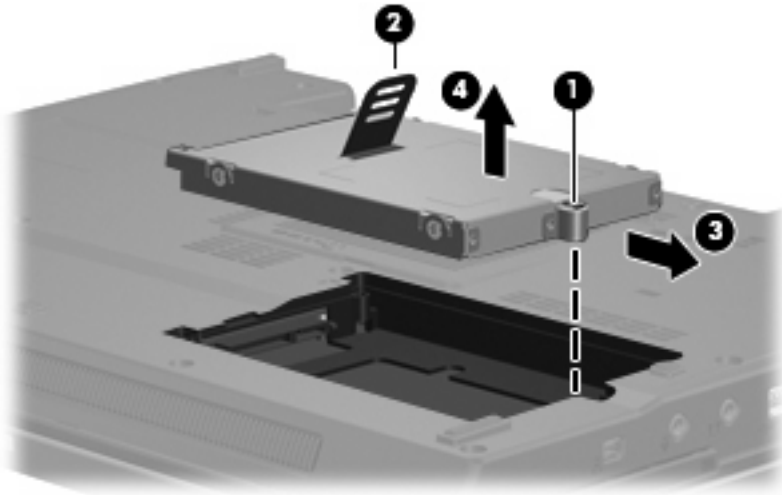

7. If it is necessary to replace the hard drive bracket, remove the two Phillips PM3.0×3.0 hard drive bracket screws **(1)** from each side of the hard drive.
8. Lift the bracket **(2)** straight up to remove it from the hard drive.

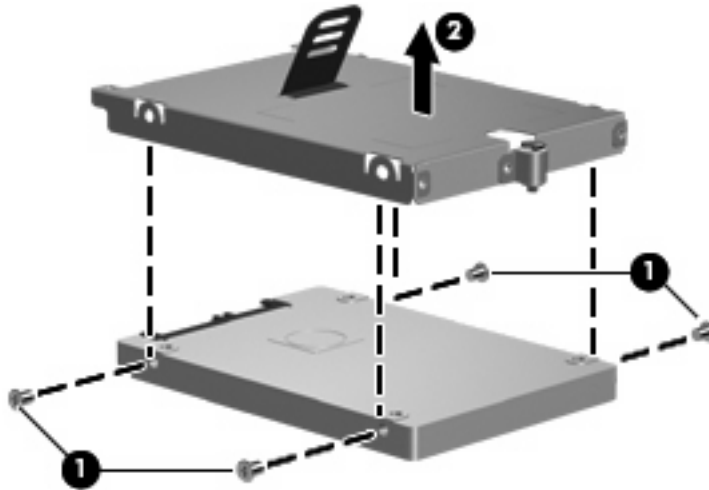

Reverse this procedure to reassemble and install the hard drive.

Computer feet

The computer feet are adhesive-backed rubber pads. The feet are included in the Plastics Kit, spare part number 443905-001. There are 8 rubber feet in 2 different sizes. The feet attach to the base enclosure in the locations illustrated below.

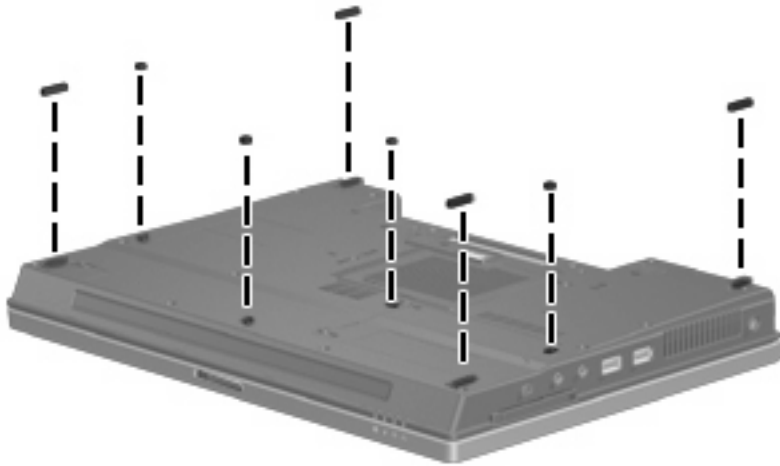

Bluetooth module

Description	Spare part number
For use with computer models in all countries and regions except Japan and Asia/Pacific (includes Bluetooth module cable)	398393-002
For use with computer models in Japan and Asia/Pacific countries and regions (includes Bluetooth module cable)	450066-001

Before removing the memory module, follow these steps:

1. Shut down the computer. If you are unsure whether the computer is off or in Hibernation, turn the computer on, and then shut it down through the operating system.
2. Disconnect all external devices connected to the computer.
3. Disconnect the power from the computer by first unplugging the power cord from the AC outlet and then unplugging the AC adapter from the computer.
4. Remove the battery (see [Battery on page 48](#)).

Remove the Bluetooth® module:

1. Position the computer with the front toward you.
2. Loosen the Phillips PM2.0×5.0 screw **(1)** that secures the Bluetooth module cover to the computer.

3. Lift the rear edge of the cover **(2)**, swing it toward you, and remove the cover.

 **NOTE:** The Bluetooth module cover is included in the Plastics Kit, spare part number 443905-001.

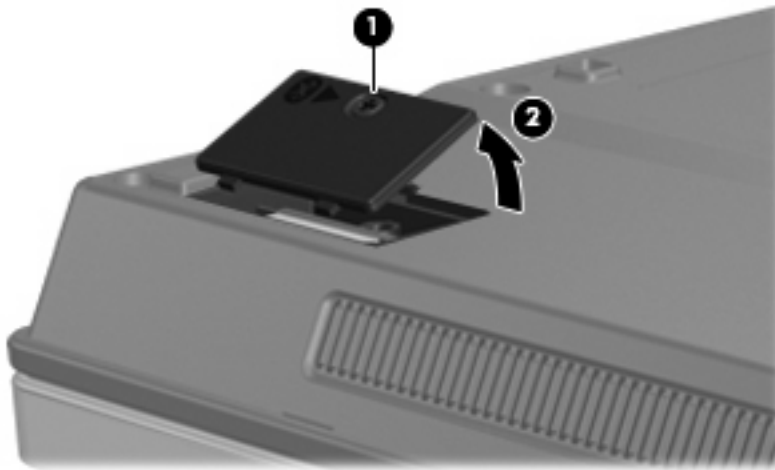

4. Remove the Bluetooth module **(1)** from the computer.
5. Disconnect the Bluetooth module cable **(2)** from the module.

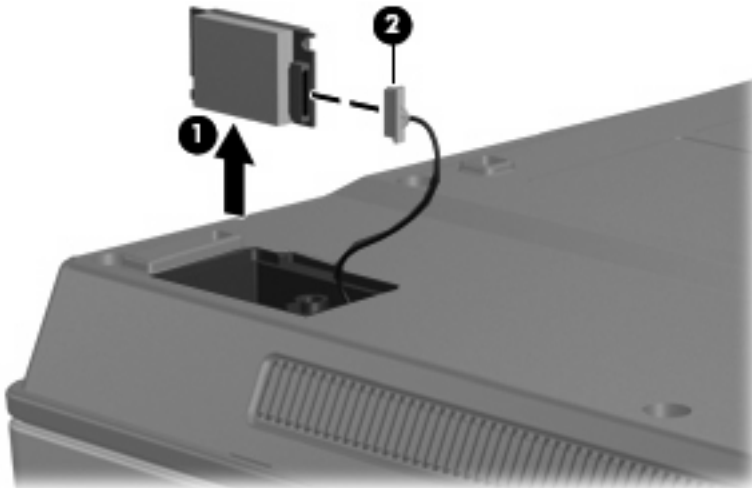

6. Remove the Bluetooth module.

Reverse this procedure to reassemble and install the Bluetooth module.

Expansion memory module

Description	Spare part number
2048-MB, PC2-5300, 1-DIMM, memory module	417506-001
1024-MB, PC2-5300, 1-DIMM, memory module	414046-001
512-MB, PC2-5300, 1-DIMM, memory module	414045-001

Before removing the expansion memory module, follow these steps:

1. Shut down the computer. If you are unsure whether the computer is off or in Hibernation, turn the computer on, and then shut it down through the operating system.
2. Disconnect all external devices connected to the computer.
3. Disconnect the power from the computer by first unplugging the power cord from the AC outlet and then unplugging the AC adapter from the computer.
4. Remove the battery (see [Battery on page 48](#)).

Remove the expansion memory module:

1. Loosen the Phillips PM2.0×5.0 screw **(1)** that secures the memory/WLAN module compartment cover to the computer.
2. Lift the rear edge of the cover **(2)**, swing it toward you, and remove the cover.

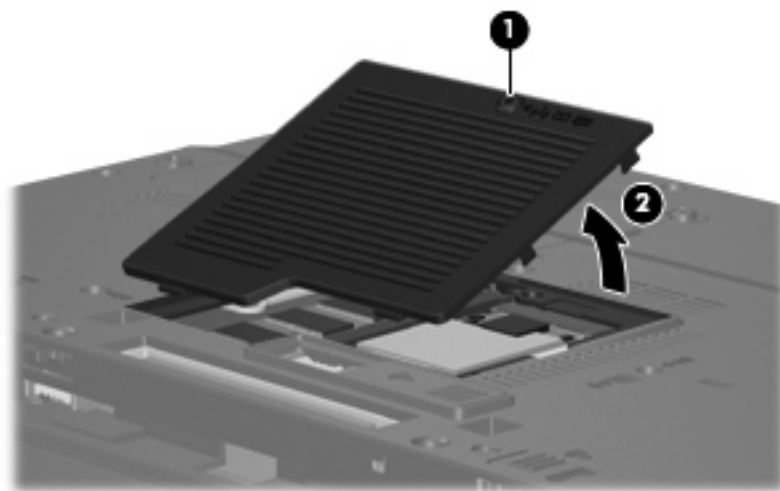

 **NOTE:** The memory/WLAN module compartment cover is included in the Plastics Kit, spare part number 443905-001.

3. Spread the retaining tabs **(1)** on each side of the memory module slot to release the memory module. (The edge of the module opposite the slot rises away from the computer.)

4. Remove the memory module **(2)** by pulling the module away from the slot at an angle.

 **NOTE:** Memory modules are designed with a notch **(3)** to prevent incorrect installation into the memory module slot.

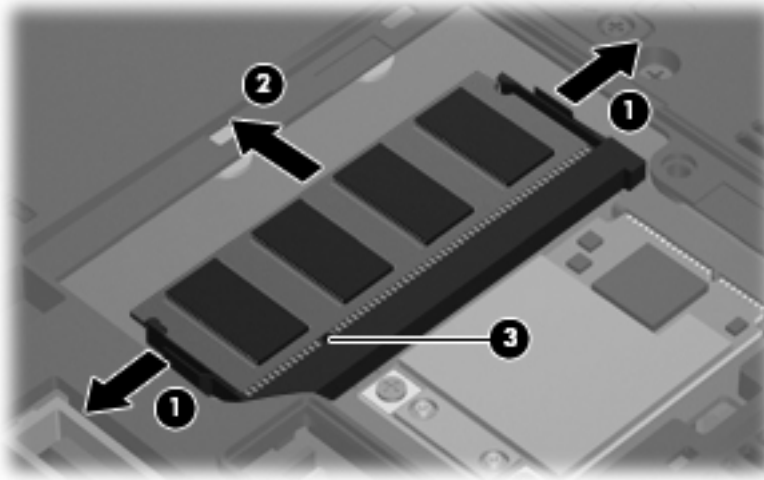

Reverse this procedure to install the expansion memory module.

WLAN module

△ **CAUTION:** The WLAN module and WWAN module are not interchangeable.

Description	Spare part number
802.11a/b/g/n Broadcom WLAN module for use with all computer models	
For use in Canada, the Cayman Islands, Guam, Puerto Rico, the United States, and the Virgin Islands	441530-001
For use in Afghanistan, Albania, Algeria, Andorra, Angola, Antigua & Barbuda, Argentina, Armenia, Aruba, Australia, Austria, Azerbaijan, the Bahamas, Bahrain, Bangladesh, Barbados, Belgium, Belize, Benin, Bermuda, Bhutan, Bolivia, Bosnia & Herzegovina, Botswana, Brazil, the British Virgin Islands, Brunei, Bulgaria, Burkina Faso, Burundi, Cameroon, Cape Verde, the Central African Republic, Chad, Chile, China, Colombia, Comoros, Congo, Costa Rica, Croatia, Cyprus, the Czech Republic, Denmark, Djibouti, Dominica, the Dominican Republic, East Timor, Ecuador, Egypt, El Salvador, Equatorial Guinea, Eritrea, Estonia, Ethiopia, Fiji, Finland, France, French Guiana, Gabon, Gambia, Georgia, Germany, Ghana, Gibraltar, Greece, Grenada, Guadeloupe, Guatemala, Guinea, Guinea-Bissau, Guyana, Haiti, Honduras, Hong Kong, Hungary, Iceland, India, Ireland, Italy, the Ivory Coast, Jamaica, Jordan, Kazakhstan, Kenya, Kiribati, Kyrgyzstan, Laos, Latvia, Lebanon, Lesotho, Liberia, Liechtenstein, Lithuania, Luxembourg, Macedonia, Madagascar, Malawi, the Maldives, Mali, Malta, the Marshall Islands, Martinique, Mauritania, Mauritius, Mexico, Micronesia, Monaco, Mongolia, Montenegro, Morocco, Mozambique, Namibia, Nauru, Nepal, the Nether Antilles, the Netherlands, New Zealand, Nicaragua, Niger, Nigeria, Norway, Oman, Pakistan, Palau, Panama, Papua New Guinea, Paraguay, Peru, the Philippines, Poland, Portugal, Puerto Rico, the Republic of Moldova, Romania, Russia, Rwanda, Samoa, San Marino, Sao Tome & Principe, Saudi Arabia, Senegal, Serbia and Montenegro, the Seychelles, Sierra Leone, Singapore, Slovakia, Slovenia, the Solomon Islands, Somalia, South Africa, Spain, Sri Lanka, St. Kitts & Nevis, St. Lucia, St. Vincent & Gren, Suriname, Swaziland, Sweden, Switzerland, Taiwan, Tajikistan, Tanzania, Togo, Tonga, Trinidad & Tobago, Tunisia, Turkey, Turkmenistan, Tuvalu, Uganda, the United Arab Emirates, the United Kingdom, Uruguay, Uzbekistan, Vanuatu, Venezuela, Vietnam, Yemen, Zaire, Zambia, and Zimbabwe	441530-002
For use in Israel and Japan	441530-291
802.11a/b/g/n Intel WLAN modules for use with HP Compaq 6710 computer models	
For use in Antigua and Barbuda, Argentina, Aruba, the Bahamas, Barbados, Bermuda, Brunei, Canada, the Cayman Islands, Chile, Colombia, Costa Rica, the Dominican Republic, Ecuador, El Salvador, Guam, Guatemala, Haiti, Honduras, Hong Kong, India, Indonesia, Malaysia, Mexico, Panama, Paraguay, Peru, Saudi Arabia, Taiwan, Uruguay, the United States, Venezuela, and Vietnam	441086-001
For use in Austria, Azerbaijan, Bahrain, Belgium, Brazil, Bulgaria, Croatia, Cyprus, the Czech Republic, Denmark, Egypt, Estonia, Finland, France, Georgia, Germany, Greece, Hungary, Iceland, Ireland, Israel, Italy, Latvia, Lebanon, Liechtenstein, Lithuania, Luxembourg, Malta, Monaco, the Netherlands, Norway, Oman, the Philippines, Poland, Portugal, Qatar, Romania, Russia, Serbia and Montenegro, Singapore, Slovakia, Slovenia, South Africa, Spain, Sri Lanka, Sweden, Switzerland, Turkey, Ukraine, the United Kingdom, and Uzbekistan	441086-002
For use in Australia, New Zealand, Pakistan, the People's Republic of China, and South Korea	441086-003
For use in Japan	441086-291
802.11a/b/g Broadcom WLAN modules for use with all computer models	
For use in Canada, the Cayman Islands, Guam, Puerto Rico, the United States, and the Virgin Islands	441075-001
For use in Afghanistan, Albania, Algeria, Andorra, Angola, Antigua & Barbuda, Argentina, Armenia, Aruba, Australia, Austria, Azerbaijan, the Bahamas, Bahrain, Bangladesh, Barbados, Belarus, Belgium, Belize, Benin, Bermuda, Bhutan, Bolivia, Bosnia & Herzegovina, Botswana, Brazil, the British Virgin Islands, Brunei, Bulgaria, Burkina Faso, Burundi, Cameroon, Cape Verde, the Central African Republic, Chad, Chile, China, Colombia, Comoros, Congo, Costa Rica, Croatia, Cyprus, the Czech Republic, Denmark, Djibouti, Dominica, the Dominican Republic, East Timor, Ecuador, Egypt, El Salvador, Equatorial Guinea, Eritrea, Estonia, Ethiopia, Fiji, Finland, France, French Guiana, Gabon, Gambia, Georgia, Germany, Ghana, Gibraltar, Greece, Grenada, Guadeloupe, Guatemala, Guinea, Guinea-Bissau, Guyana, Haiti, Honduras, Hong Kong, Hungary, Iceland, India, Ireland, Israel,	441075-002

Description	Spare part number
Italy, the Ivory Coast, Jamaica, Jordan, Kazakhstan, Kenya, Kiribati, Kyrgyzstan, Laos, Latvia, Lebanon, Lesotho, Liberia, Liechtenstein, Lithuania, Luxembourg, Macedonia, Madagascar, Malawi, Malaysia, the Maldives, Mali, Malta, the Marshall Islands, Martinique, Mauritania, Mauritius, Mexico, Micronesia, Monaco, Mongolia, Montenegro, Morocco, Mozambique, Namibia, Nauru, Nepal, the Nether Antilles, the Netherlands, New Zealand, Nicaragua, Niger, Nigeria, Norway, Oman, Pakistan, Palau, Panama, Papua New Guinea, Paraguay, Peru, the Philippines, Poland, Portugal, the Republic of Moldova, Romania, Russia, Rwanda, Samoa, San Marino, Sao Tome & Principe, Saudi Arabia, Senegal, Serbia and Montenegro, the Seychelles, Sierra Leone, Singapore, Slovakia, Slovenia, the Solomon Islands, Somalia, South Africa, South Korea, Spain, Sri Lanka, St. Kitts & Nevis, St. Lucia, St. Vincent & Gren, Suriname, Swaziland, Sweden, Switzerland, Taiwan, Tajikistan, Tanzania, Togo, Tonga, Trinidad & Tobago, Tunisia, Turkey, Turkmenistan, Tuvalu, Uganda, Ukraine, the United Arab Emirates, the United Kingdom, Uruguay, Uzbekistan, Vanuatu, Venezuela, Vietnam, Yemen, Zaire, Zambia, and Zimbabwe	
For use in Israel and Japan	441075-291
802.11a/b/g Intel WLAN modules for use with HP Compaq 6710 computer models	
For use in Antigua & Barbuda, Argentina, Aruba, the Bahamas, Barbados, Bermuda, Brunei, Canada, the Cayman Islands, Chile, Colombia, Costa Rica, the Dominican Republic, Ecuador, El Salvador, Guam, Guatemala, Haiti, Honduras, Hong Kong, India, Indonesia, Malaysia, Mexico, Panama, Paraguay, Peru, Saudi Arabia, Taiwan, the United States, Uruguay, Venezuela, and Vietnam	441082-001
For use in Austria, Azerbaijan, Bahrain, Belgium, Brazil, Bulgaria, Croatia, Cyprus, the Czech Republic, Denmark, Egypt, Estonia, Finland, France, Georgia, Germany, Greece, Hungary, Iceland, Ireland, Israel, Italy, Latvia, Lebanon, Liechtenstein, Lithuania, Luxembourg, Malta, Monaco, the Netherlands, Norway, Oman, the Philippines, Poland, Portugal, Qatar, Romania, Russia, Serbia and Montenegro, Singapore, Slovakia, Slovenia, South Africa, Spain, Sri Lanka, Sweden, Switzerland, Turkey, Ukraine, the United Kingdom, and Uzbekistan	441082-002
For use in Australia, New Zealand, Pakistan, the People's Republic of China, and South Korea	441082-003
For use in Japan	441082-291
802.11a/b/g Intel WLAN modules for use with HP Compaq 6710 computer models	
For use in Antigua and Barbuda, Argentina, Australia, the Bahamas, Barbados, Brunei, Canada, Chile, the Dominican Republic, Guam, Guatemala, Hong Kong, India, Indonesia, Malaysia, Mexico, New Zealand, Panama, Paraguay, Saudi Arabia, Taiwan, the United States, and Vietnam	407575-001
For use in Aruba, Austria, Azerbaijan, Bahrain, Belgium, Bermuda, Brazil, Bulgaria, the Cayman Islands, Colombia, Croatia, Cyprus, the Czech Republic, Denmark, Egypt, El Salvador, Estonia, Finland, France, Georgia, Germany, Greece, Hungary, Iceland, Ireland, Italy, Jordan, Latvia, Lebanon, Liechtenstein, Lithuania, Luxembourg, Malta, Monaco, the Netherlands, Norway, Oman, the Philippines, Poland, Portugal, Romania, Russia, Serbia and Montenegro, Singapore, Slovakia, Slovenia, South Africa, Spain, Sri Lanka, Sweden, Switzerland, Turkey, the United Kingdom, and Uzbekistan	407575-002
For use in Ecuador, Haiti, Honduras, Pakistan, the People's Republic of China, Peru, Qatar, South Korea, Uruguay, and Venezuela	407575-003
For use in Japan	407575-291
802.11b/g Broadcom WLAN module for use with all computer models	
For use in Canada, the Cayman Islands, Guam, Puerto Rico, the United States, and the U.S. Virgin Islands	441060-001
For use in Afghanistan, Albania, Algeria, Andorra, Angola, Antigua & Barbuda, Argentina, Armenia, Aruba, Australia, Austria, Azerbaijan, the Bahamas, Bahrain, Bangladesh, Barbados, Belarus, Belgium, Belize, Benin, Bermuda, Bhutan, Bolivia, Bosnia & Herzegovina, Botswana, Brazil, the British Virgin Islands, Brunei, Bulgaria, Burkina Faso, Burundi, Cambodia, Cameroon, Cape Verde, the Central African Republic, Chad, Chile, China, Colombia, Comoros, Congo, Costa Rica, Croatia, Cyprus, the Czech Republic, Denmark, Djibouti, Dominica, the Dominican Republic, East Timor, Ecuador, Egypt, El Salvador, Equatorial Guinea, Eritrea, Estonia, Ethiopia, Fiji, Finland, France, French	441060-002

Description	Spare part number
Guiana, Gabon, Gambia, Georgia, Germany, Ghana, Gibraltar, Greece, Grenada, Guadeloupe, Guatemala, Guinea, Guinea-Bissa, Guyana, Haiti, Honduras, Hong Kong, Hungary, Iceland, India, Indonesia, Ireland, Israel, Italy, the Ivory Coast, Jamaica, Jordan, Kazakhstan, Kenya, Kiribati, Kuwait, Kyrgyzstan, Laos, Latvia, Lebanon, Lesotho, Liberia, Liechtenstein, Lithuania, Luxembourg, Macedonia, Madagascar, Malawi, Malaysia, the Maldives, Mali, Malta, the Marshall Islands, Martinique, Mauritania, Mauritius, Mexico, Micronesia, Monaco, Mongolia, Montenegro, Morocco, Mozambique, Namibia, Nauru, Nepal, the Nether Antilles, the Netherlands, New Zealand, Nicaragua, Niger, Nigeria, Norway, Oman, Pakistan, Palau, Panama, Papua New Guinea, Paraguay, Peru, the Philippines, Poland, Portugal, Qatar, the Republic of Moldova, Romania, Russia, Rwanda, Samoa, San Marino, Sao Tome & Principe, Saudi Arabia, Senegal, Serbia and Montenegro, the Seychelles, Sierra Leone, Singapore, Slovakia, Slovenia, the Solomon Islands, Somalia, South Africa, South Korea, Spain, Sri Lanka, St. Kitts & Nevis, St. Lucia, St. Vincent & Gren, Suriname, Swaziland, Sweden, Switzerland, Taiwan, Tajikistan, Tanzania, Thailand, Togo, Tonga, Trinidad & Tobago, Tunisia, Turkey, Turkmenistan, Tuvalu, Uganda, Ukraine, the United Arab Emirates, the United Kingdom, Uruguay, Uzbekistan, Vanuatu, Venezuela, Vietnam, Yemen, Zaire, Zambia, and Zimbabwe	
For use in Japan	441060-291
802.11b/g Intel WLAN module for use with HP Compaq 6710 computer models in Thailand	409280-004

Before removing the WLAN module, follow these steps:

1. Shut down the computer. If you are unsure whether the computer is off or in Hibernation, turn the computer on, and then shut it down through the operating system.
2. Disconnect all external devices connected to the computer.
3. Disconnect the power from the computer by first unplugging the power cord from the AC outlet and then unplugging the AC adapter from the computer.
4. Remove the battery (see [Battery on page 48](#)).
5. Remove the memory/WLAN module compartment cover (see [Expansion memory module on page 56](#)).

Remove the WLAN module:

1. Disconnect the WLAN antenna cables **(1)** from the terminals on the WLAN module.

 **NOTE:** The black WLAN antenna cable is connected to the WLAN module “Main” terminal. The white WLAN antenna cable is connected to the WLAN module “Aux” terminal. If the computer is equipped with an 802.11a/b/g/n WLAN module, the yellow WLAN antenna cable **(2)** is connected to the middle terminal on the WLAN module.
2. Remove the two Phillips PM2.5×3.0 screws **(3)** that secure the WLAN module to the computer. (The edge of the module opposite the slot rises away from the computer.)

3. Remove the WLAN module **(4)** by pulling the module away from the slot at an angle.

 **NOTE:** WLAN modules are designed with a notch **(5)** to prevent incorrect installation.

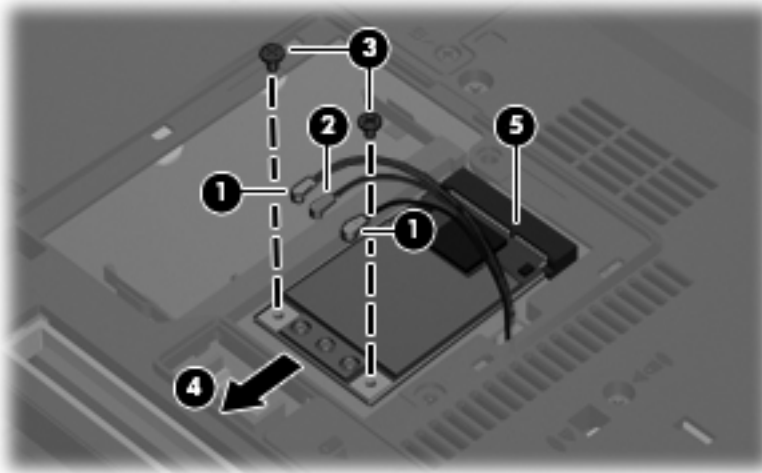

Reverse this procedure to install the WLAN module.

Optical drive

 **NOTE:** All optical drive spare part kits include an optical drive bezel and optical drive bracket.

Description	Spare part number
DVD±RW and CD-RW Super Multi Double-Layer Combo Drive with LightScribe	443903-001
DVD±RW and CD-RW Super Multi Double-Layer Combo Drive	443904-001
DVD/CD-RW Combo Drive	443901-001
DVD-ROM drive	443902-001

Before removing the optical drive, follow these steps:

1. Shut down the computer. If you are unsure whether the computer is off or in Hibernation, turn the computer on, and then shut it down through the operating system.
2. Disconnect all external devices connected to the computer.
3. Disconnect the power from the computer by first unplugging the power cord from the AC outlet and then unplugging the AC adapter from the computer.
4. Remove the battery (see [Battery on page 48](#)).
5. Remove the memory/WLAN module compartment cover (see [Expansion memory module on page 56](#)).

Remove the optical drive:

1. Position the computer with left side toward you.
2. Remove the Torx T8M2.5×9.0 screw **(1)** that secures the optical drive to the computer.
3. Use a flat-bladed tool to push the metal tab **(2)** toward the left side of the computer. (The optical drive is partially ejected from the optical drive bay.)
4. Remove the optical drive **(3)** from the computer.

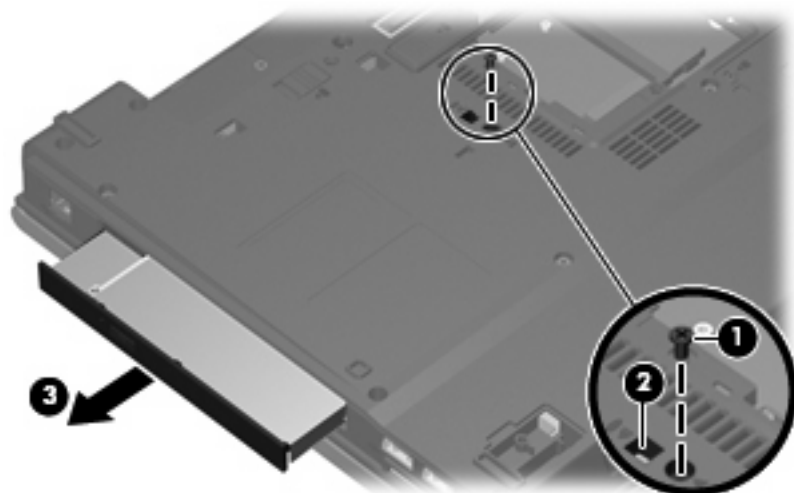

5. If it is necessary to replace the optical drive bracket, remove the two Phillips PM2.0×3.0 screws **(1)** that secure the bracket to the optical drive.
6. Remove the optical drive bracket **(2)**.

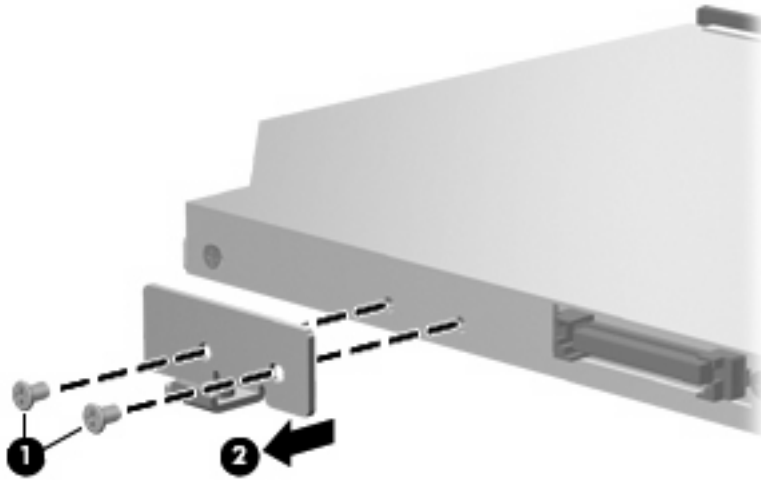

Reverse this procedure to reassemble and install the optical drive.

Keyboard

For use in	Spare part number	For use in	Spare part number
Belgium	443811-181	Latin America	443811-161
Brazil	443811-201	Norway	443811-091
The Czech Republic	443811-221	Portugal	443811-131
Denmark	443811-081	Russia	443811-251
France	443811-051	Saudi Arabia	443811-171
French Canada	443811-121	Slovakia	443811-231
Germany	443811-041	Slovenia	443811-BA1
Greece	443811-DJ1	Spain	443811-071
Hungary	443811-211	Sweden and Finland	443811-B71
International	443811-B31	Switzerland	443811-BG1
Iceland	443811-DD1	Taiwan	443811-AB1
Israel	443811-BB1	Thailand	443811-281
Italy	443811-061	Turkey	443811-141
Japan	443811-291	The United Kingdom	443811-031
Korea	443811-AD1	The United States	443811-001

Before removing the keyboard, follow these steps:

1. Shut down the computer. If you are unsure whether the computer is off or in Hibernation, turn the computer on, and then shut it down through the operating system.
2. Disconnect all external devices connected to the computer.
3. Disconnect the power from the computer by first unplugging the power cord from the AC outlet and then unplugging the AC adapter from the computer.
4. Remove the battery (see [Battery on page 48](#)).
5. Remove the memory/WLAN module compartment cover (see [Expansion memory module on page 56](#)).

Remove the keyboard:

1. Position the computer with the front toward you.

2. Loosen the three Phillips PM2.5×8.0 screws that secure the keyboard to the computer.

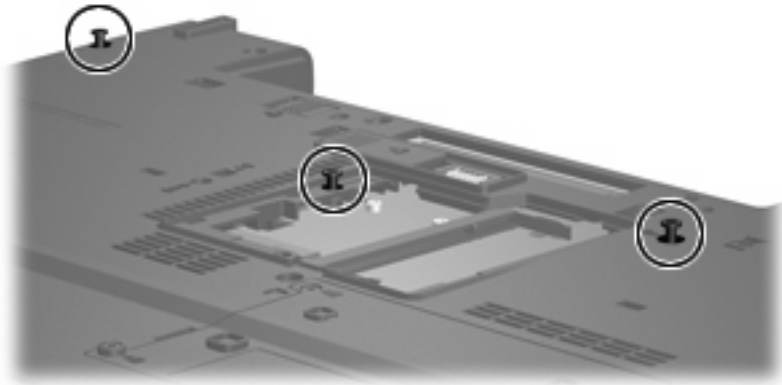

3. Turn the computer display-side up, with the front toward you.
4. Open the computer as far as possible.
5. Slide the four keyboard retention tabs **(1)** toward you. The tabs are located between the **esc** and **f1** keys, between the **f4** and **f5** keys, between the **f8** and **f9** keys, and between the **f12** and **scroll** keys.
6. Lift the rear edge of the keyboard **(2)** and swing it toward you until it rests on the palm rest.



7. Release the zero insertion force (ZIF) connector **(1)** to which the keyboard cable is attached and disconnect the keyboard cable **(2)** from the system board.

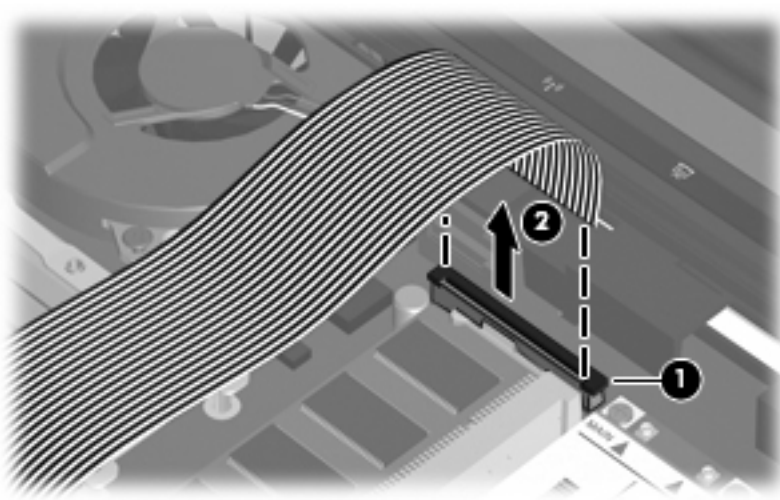

8. Remove the keyboard.

Reverse this procedure to install the keyboard.

Internal memory module

Description	Spare part number
2048-MB, PC2-5300, 1-DIMM, memory module	417506-001
1024-MB, PC2-5300, 1-DIMM, memory module	414046-001
512-MB, PC2-5300, 1-DIMM, memory module	414045-001

Before removing the internal memory module, follow these steps:

1. Shut down the computer. If you are unsure whether the computer is off or in Hibernation, turn the computer on, and then shut it down through the operating system.
2. Disconnect all external devices connected to the computer.
3. Disconnect the power from the computer by first unplugging the power cord from the AC outlet and then unplugging the AC adapter from the computer.
4. Remove the battery (see [Battery on page 48](#)).
5. Remove the memory/WLAN module compartment cover (see [Expansion memory module on page 56](#)).
6. Release the keyboard (see [Keyboard on page 64](#)).

Remove the internal memory module:

1. Spread the retaining tabs **(1)** on each side of the memory module slot to release the memory module. (The edge of the module opposite the slot rises away from the computer.)

2. Remove the memory module **(2)** by pulling the module away from the slot at an angle.

 **NOTE:** Memory modules are designed with a notch **(3)** to prevent incorrect installation into the memory module slot.

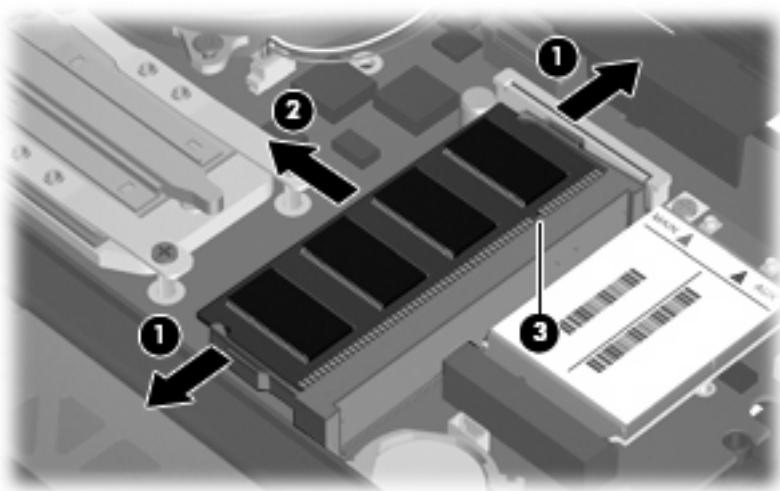

Reverse this procedure to install the internal memory module.

RTC battery

 **NOTE:** Removing the RTC battery and leaving it uninstalled for 5 or more minutes causes all passwords and CMOS settings to be cleared.

Description	Spare part number
RTC battery	449137-001

Before removing the RTC battery, follow these steps:

1. Shut down the computer. If you are unsure whether the computer is off or in Hibernation, turn the computer on, and then shut it down through the operating system.
2. Disconnect all external devices connected to the computer.
3. Disconnect the power from the computer by first unplugging the power cord from the AC outlet and then unplugging the AC adapter from the computer.
4. Remove the battery (see [Battery on page 48](#)).
5. Remove the memory/WLAN module compartment cover (see [Expansion memory module on page 56](#)).
6. Release the keyboard (see [Keyboard on page 64](#)).

Remove the RTC battery:

- Use a non-conductive, flat-bladed tool to pry the RTC battery out of the slot.

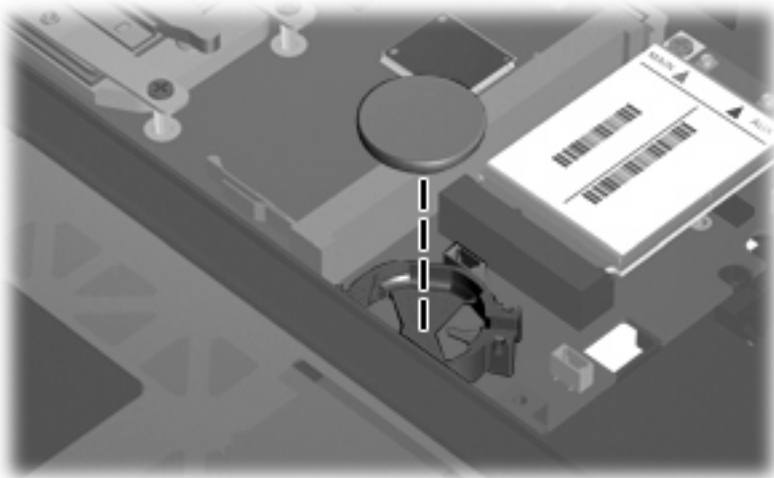

Reverse this procedure to install the RTC battery. Be sure the RTC battery is installed with the “+” sign facing up.

WWAN module

- △ **CAUTION:** The WWAN module and WLAN module are not interchangeable.

Description	Spare part number
EVDO WWAN module	399440-001
Vodafone HSPDA WWAN module	448672-002
Cingular HSPDA WWAN module	448673-002

Before removing the WWAN module, follow these steps:

1. Shut down the computer. If you are unsure whether the computer is off or in Hibernation, turn the computer on, and then shut it down through the operating system.
2. Disconnect all external devices connected to the computer.
3. Disconnect the power from the computer by first unplugging the power cord from the AC outlet and then unplugging the AC adapter from the computer.
4. Remove the battery (see [Battery on page 48](#)).
5. Remove the memory/WLAN module compartment cover (see [Expansion memory module on page 56](#)).
6. Release the keyboard (see [Keyboard on page 64](#)).

Remove the WWAN module:

1. Disconnect the WWAN antenna cables **(1)** from the terminals on the WWAN module.

 **NOTE:** The red WWAN antenna cable is connected to the WWAN module “Main” terminal. The blue WWAN antenna cable is connected to the WWAN module “Aux” terminal. If the computer is equipped with an HSPDA WWAN module, the red WWAN antenna cable is connected to the only terminal on the module.

2. Remove the two Phillips PM2.5×3.0 screws **(2)** that secure the WWAN module to the computer. (The edge of the module opposite the slot rises away from the computer.)

3. Remove the WWAN module **(3)** by pulling the module away from the slot at an angle.

 **NOTE:** WWAN modules are designed with a notch **(4)** to prevent incorrect installation.

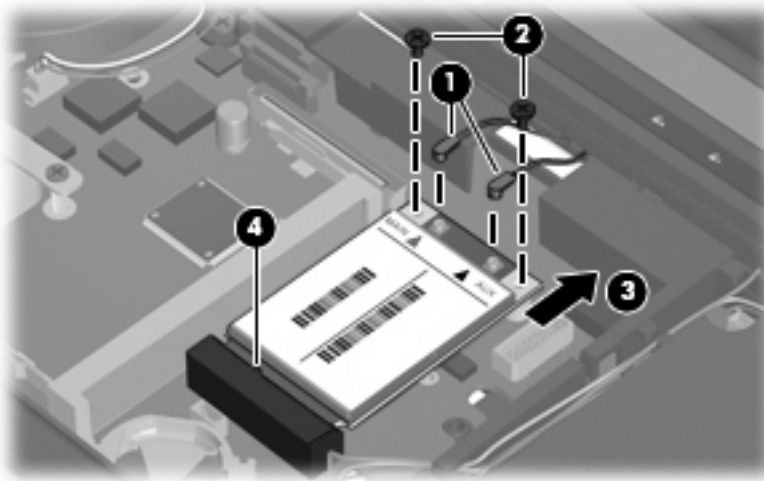

Reverse this procedure to install the WWAN module.

Switch cover

Description	Spare part number
Switch cover for use with HP Compaq 6715b and 6710b computer models (includes power button board and cable and LED board and cable)	443911-001
Switch cover for use with HP Compaq 6715s and 6710s computer models (includes power button board and cable, but does not include LED board and cable)	443910-001

Before removing the switch cover, follow these steps:

1. Shut down the computer. If you are unsure whether the computer is off or in Hibernation, turn the computer on, and then shut it down through the operating system.
2. Disconnect all external devices connected to the computer.
3. Disconnect the power from the computer by first unplugging the power cord from the AC outlet and then unplugging the AC adapter from the computer.
4. Remove the battery (see [Battery on page 48](#)).
5. Release the keyboard (see [Keyboard on page 64](#)).

Remove the switch cover:

 **NOTE:** Step 1 applies only to HP Compaq 6715b and 6710b computer models.

1. Release the ZIF connector **(1)** to which the LED board cable is attached and disconnect the LED board cable **(2)** from the system board.
2. Insert a flat-bladed tool into one of the four slots **(3)** in the switch cover and lift the switch cover **(4)** until it disengages from the computer.

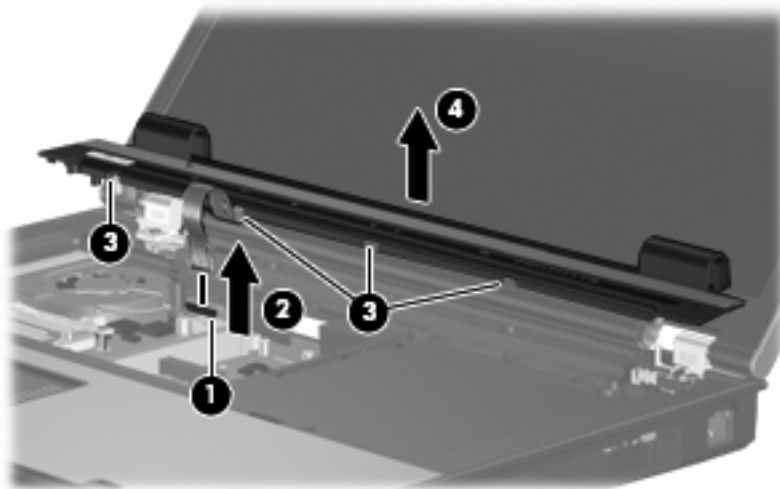

3. Remove the switch cover.

Reverse this procedure to install the switch cover.

Fan

Description	Spare part number
Fan	443917-001

Before removing the fan, follow these steps:

1. Shut down the computer. If you are unsure whether the computer is off or in Hibernation, turn the computer on, and then shut it down through the operating system.
2. Disconnect all external devices connected to the computer.
3. Disconnect the power from the computer by first unplugging the power cord from the AC outlet and then unplugging the AC adapter from the computer.
4. Remove the battery (see [Battery on page 48](#)).
5. Release the keyboard (see [Keyboard on page 64](#)).
6. Remove the switch cover (see [Switch cover on page 70](#)).

Remove the fan:

1. Disconnect the fan cable **(1)** from the system board.

 **NOTE:** The illustration below shows the fan removal steps for the HP Compaq 6715 computer model. The fan cable on the HP Compaq 6710 computer model is in a different location, but the disconnection steps are the same.

2. Loosen the Phillips PM2.5×8.0 captive screw **(2)** that secures the fan to the computer.
3. Remove the Phillips PM2.5×8.0 screw **(3)** that secures the fan to the computer.
4. Remove the fan **(4)**.

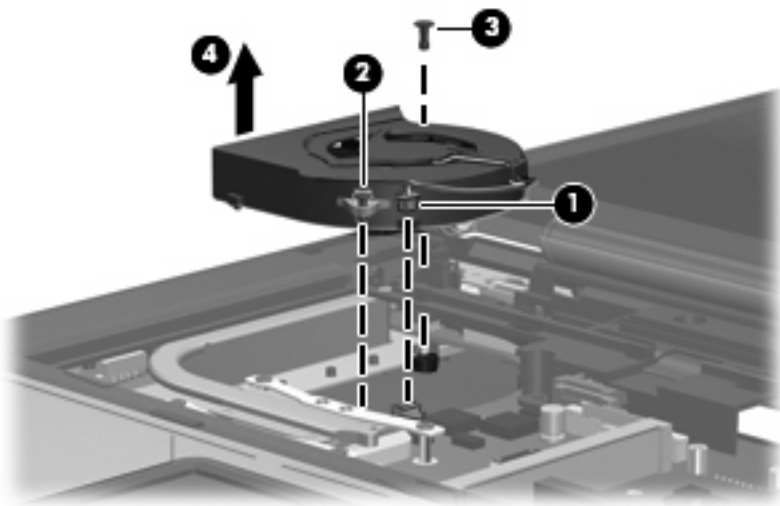

Reverse this procedure to install the fan.

 **NOTE:** To properly ventilate the computer, allow at least a 7.6-cm (3-inch) clearance on the left and right sides of the computer.

The computer uses an electric fan for ventilation. The fan is controlled by a temperature sensor and is designed to turn on automatically when high temperature conditions exist. These conditions are affected by high external temperatures, system power consumption, power management/battery conservation configurations, battery fast charging, and software applications. Exhaust air is displaced through the ventilation grill located on the left side of the computer.

Heat sink

 **NOTE:** All heat sink spare part kits include thermal material.

Description	Spare part number
For use with HP Compaq 6715 computer models	443912-001
For use with HP Compaq 6710 computer models	446920-001
Thermal Material Kit for use in all countries and regions except Japan and Asia/Pacific	413706-001
Thermal Material Kit for use in Japan and Asia/Pacific countries and regions	445853-001

Before removing the heat sink, follow these steps:

1. Shut down the computer. If you are unsure whether the computer is off or in Hibernation, turn the computer on, and then shut it down through the operating system.
2. Disconnect all external devices connected to the computer.
3. Disconnect the power from the computer by first unplugging the power cord from the AC outlet and then unplugging the AC adapter from the computer.
4. Remove the battery (see [Battery on page 48](#)).
5. Release the keyboard (see [Keyboard on page 64](#)).
6. Remove the switch cover (see [Switch cover on page 70](#)).
7. Remove the internal memory module (see [Internal memory module on page 66](#)). This step applies only to HP Compaq 6710 computer models.
8. Remove the fan (see [Fan on page 71](#)).

Remove the heat sink:

 **NOTE:** Step 1 applies to HP Compaq 6715 computer models. The heat sink on HP Compaq 6710 computer models is secured to the computer by captive screws which must be loosened rather than removed.

1. Remove the four Phillips PM2.0×6.0 screws **(1)** that secure the heat sink to the system board.
2. Release the heat sink **(2)** by lifting the right side until it disengages from the processor.

 **NOTE:** Due to the adhesive quality of the thermal material located between the heat sink and processor, it may be necessary to move the heat sink from side to side to detach the heat sink from the processor.

3. Remove the heat sink **(3)** by swinging it counterclockwise until the left side of the heat sink clears the top cover.

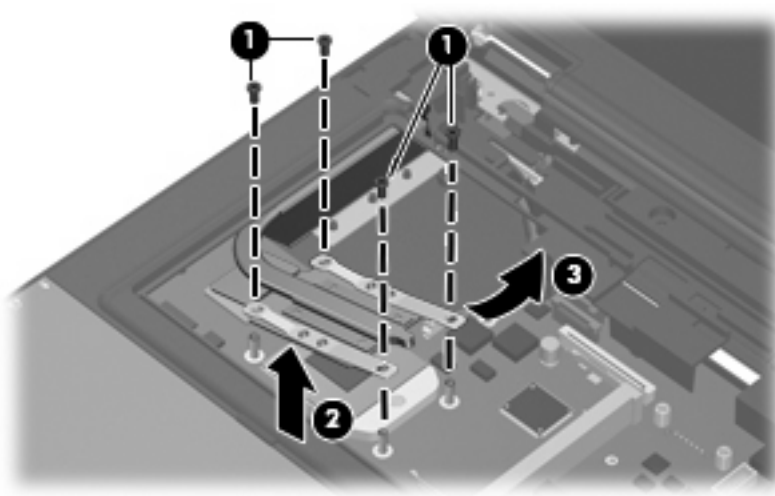

NOTE: The thermal material must be thoroughly cleaned from the surfaces of the heat sink **(1)** and the processor and system board components **(2)** each time the heat sink is removed. Thermal material is included with all heat sink and processor spare part kits.

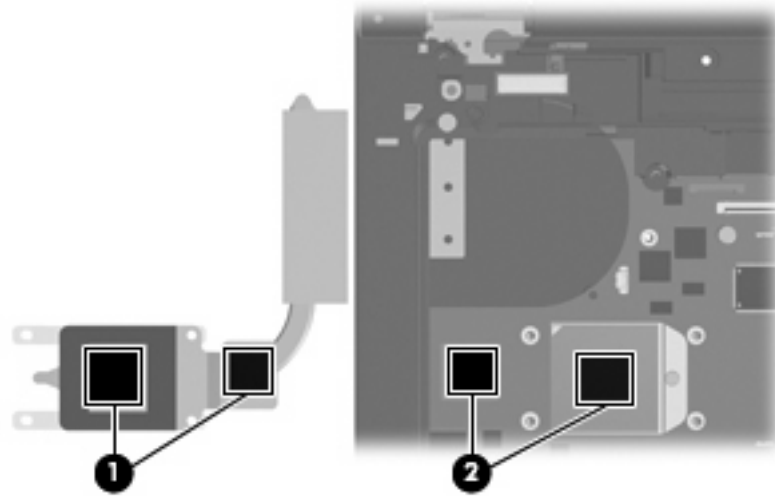

Reverse this procedure to install the heat sink.

Processor

 **NOTE:** All processor spare part kits include thermal material.

Description	Spare part number
Processors for use with HP Compaq 6715 computer models in all countries and regions except Japan and Asia/Pacific:	
AMD Turion TL-64, 2.2-GHz processor (1-MB L2 cache)	443913-001
AMD Turion MK-38, 2.2-GHz processor (512-KB L2 cache)	446045-001
AMD Turion TL-60, 2.0-GHz processor (1-MB L2 cache)	430876-001
AMD Turion TL-56, 1.8-GHz processor (1-MB L2 cache)	430875-001
AMD Turion TL-52, 1.6-GHz processor (1-MB L2 cache)	430874-001
AMD Turion TL-50, 1.6-GHz processor (1-MB L2 cache)	450939-001
Mobile AMD Sempron 3800+ 2.2-GHz processor (256-KB L2 cache)	450940-001
Mobile AMD Sempron 3600+ 2.0-GHz processor (256-KB L2 cache)	443916-001
Mobile AMD Sempron 3500+ 1.8-GHz processor (512-KB L2 cache)	430872-001
Mobile AMD Sempron 3400+ 1.8-GHz processor (256-KB L2 cache)	430871-001
Processors for use with HP Compaq 6715 computer models in Japan and Asia/Pacific countries and regions	
AMD Turion TL-60, 2.0-GHz processor (1-MB L2 cache)	443892-001
AMD Turion TL-56, 1.8-GHz processor (1-MB L2 cache)	443891-001
AMD Turion TL-52, 1.6-GHz processor (1-MB L2 cache)	443890-001
Mobile AMD Sempron 3500+ 1.8-GHz processor (512-KB L2 cache)	443915-001
Mobile AMD Sempron 3400+ 1.8-GHz processor (256-KB L2 cache)	443914-001
Processors for use with HP Compaq 6710 computer models	
Intel Core Duo T7700 2.4-GHz processor (4-MB L2 cache)	446894-001
Intel Core Duo T7500 2.2-GHz processor (4-MB L2 cache)	446893-001
Intel Core Duo T7300 2.0-GHz processor (4-MB L2 cache)	446892-001
Intel Core Duo T7100 1.8-GHz processor (2-MB L2 cache)	446891-001

Before removing the processor, follow these steps:

1. Shut down the computer. If you are unsure whether the computer is off or in Hibernation, turn the computer on, and then shut it down through the operating system.
2. Disconnect all external devices connected to the computer.
3. Disconnect the power from the computer by first unplugging the power cord from the AC outlet and then unplugging the AC adapter from the computer.
4. Remove the battery (see [Battery on page 48](#)).
5. Release the keyboard (see [Keyboard on page 64](#)).

6. Remove the switch cover (see [Switch cover on page 70](#)).
7. Remove the fan (see [Fan on page 71](#)).
8. Remove the heat sink (see [Heat sink on page 72](#)).

Remove the processor:

1. Use a flat-bladed screwdriver to turn the processor locking screw **(1)** one-half turn counterclockwise until you hear a click.
2. Lift the processor **(2)** straight up and remove it.

 **NOTE:** The gold triangle **(3)** on the processor must be aligned with the triangle **(4)** embossed on the processor slot when you install the processor. The illustration below shows the processor removal steps for the HP Compaq 6715 computer model.

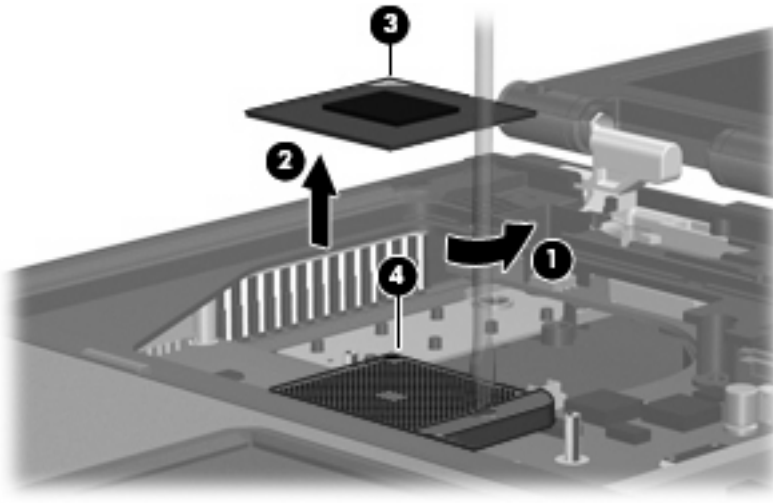

 **NOTE:** The illustration below shows the processor removal steps for the HP Compaq 6710 computer model.

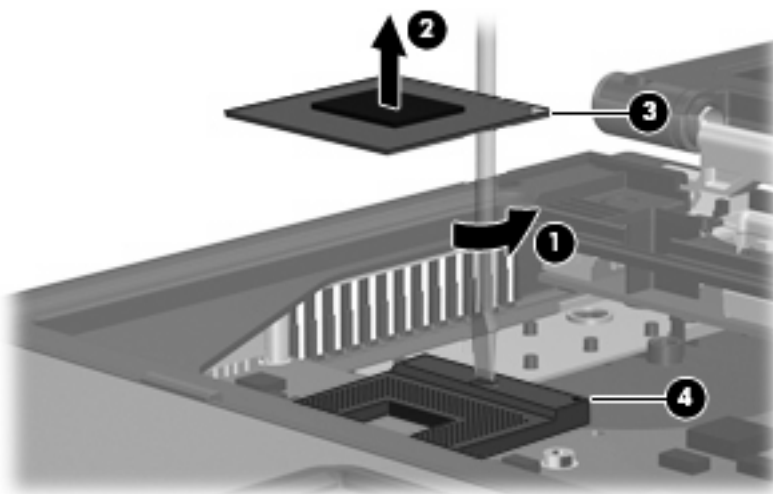

Reverse this procedure to install the processor.

Display assembly

Description	Spare part number
15.4-inch, WSXGA+ display assembly for use with HP Compaq 6715b and 6710b computer models with WWAN capability	443814-001
15.4-inch, WXGA display assembly for use with HP Compaq 6715b and 6710b computer models with WWAN capability	443817-001
15.4-inch, WXGA, BrightView display assembly for use with HP Compaq 6715b and 6710b computer models without WWAN capability	443816-001
15.4-inch, WSXGA+ display assembly for use with HP Compaq 6715b and 6710b computer models without WWAN capability	443813-001
15.4-inch, WXGA display assembly for use with HP Compaq 6715b and 6710b computer models without WWAN capability	443815-001
15.4-inch, WXGA, BrightView display assembly for use with HP Compaq 6715s and 6710s computer models	443812-001
15.4-inch, WSXGA+ display assembly for use with HP Compaq 6715s and 6710s computer models	443818-001
15.4-inch, WXGA display assembly for use with HP Compaq 6715s and 6710s computer models	443819-001

Before removing the display assembly, follow these steps:

1. Shut down the computer. If you are unsure whether the computer is off or in Hibernation, turn the computer on, and then shut it down through the operating system.
2. Disconnect all external devices connected to the computer.
3. Disconnect the power from the computer by first unplugging the power cord from the AC outlet and then unplugging the AC adapter from the computer.
4. Remove the battery (see [Battery on page 48](#)).
5. Remove the memory/WLAN module compartment cover (see [Expansion memory module on page 56](#)).
6. Disconnect the wireless antenna cables from the WLAN module (see [WLAN module on page 58](#)).
7. Remove the following components:
 - a. Keyboard (see [Keyboard on page 64](#))
 - b. Switch cover (see [Switch cover on page 70](#))

Remove the display assembly:

1. Disconnect the display panel cable **(1)** from the system board.

2. Remove the wireless antenna cables **(2)** from the routing channels and clips built into the top cover.

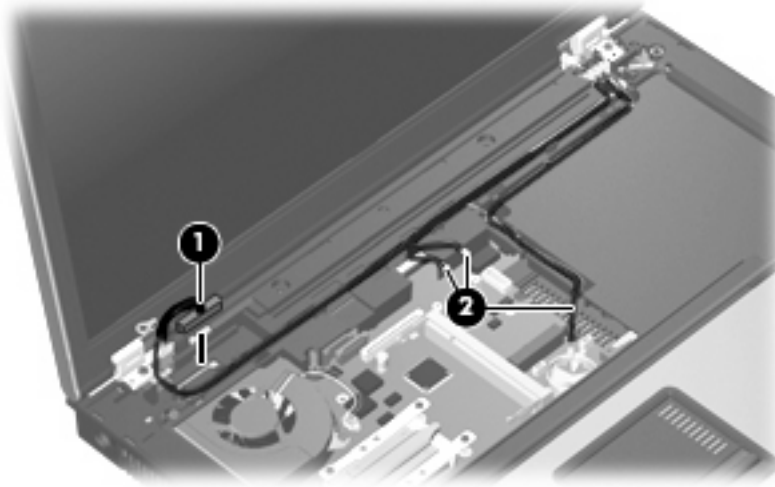

3. Remove the two Torx T8M2.5×9.0 screws **(1)** that secure the display assembly to the computer.

 **NOTE:** The screw removed from the left hinge secures a ground loop **(2)** for the display panel cable.

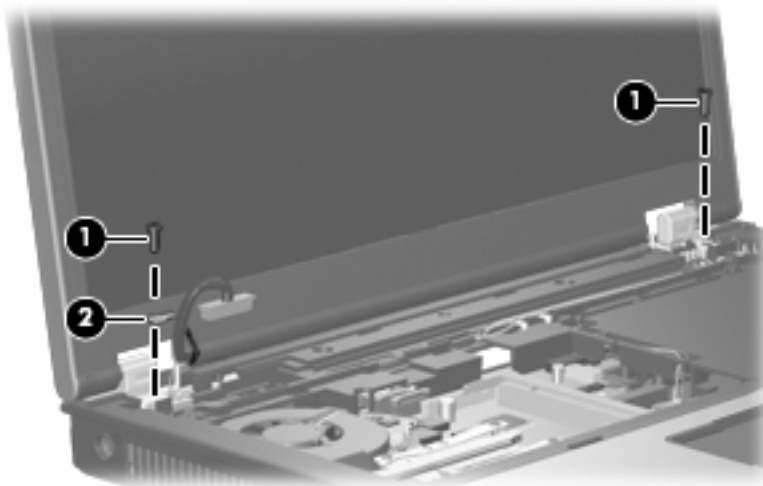

4. Position the computer with the rear panel toward you.
5. Remove the four Torx T8M2.5×9.0 screws **(1)** that secure the display assembly to the computer.

6. Lift the display assembly straight up and remove it **(2)**.

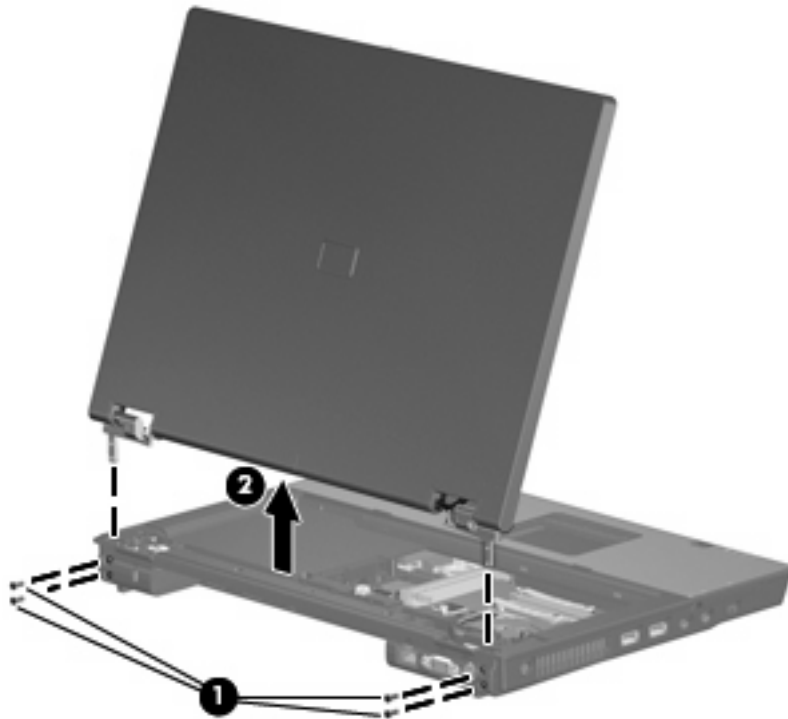

△ **CAUTION:** When installing the display assembly, be sure that the 4 wireless antenna cables routed out of the display right hinge are routed and arranged properly. Each antenna cable has an exposed section of cable **(1)** and a metallic grounding sleeve **(2)**. The grounding sleeve must completely cover the exposed section of cable. Each cable must be secured inside a space in the copper grounding clip **(3)**. Left to right, the cables must be installed in a red, white, black, blue sequence.

Failure to follow these routing instructions can result in degradation of the computer's WLAN and WWAN performance.

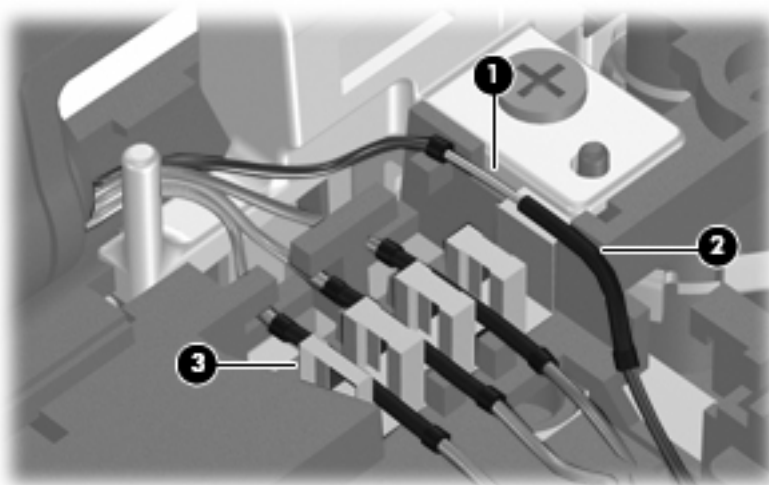

7. If it is necessary to replace the display hinges, remove the following:
- (1) Four rubber screw covers from the display bezel top edge
 - (2) Four Torx T8M2.5×6.0 screws from the display bezel top edge
 - (3) Two rubber screw covers from the display bezel bottom edge
 - (4) Two Torx T8M2.5×7.0 screws from the display bezel top edge

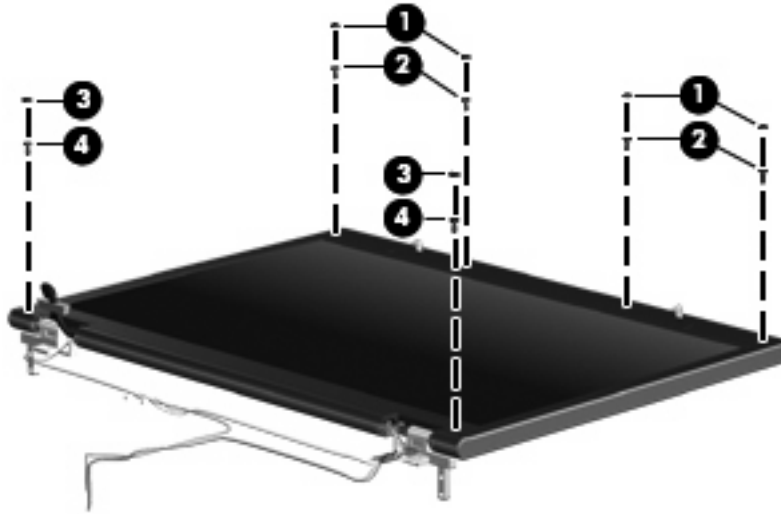

8. Flex the inside edges of the left and right sides (1) and the top and bottom sides (2) of the display bezel until the bezel disengages from the display enclosure.
9. Remove the display bezel (3).

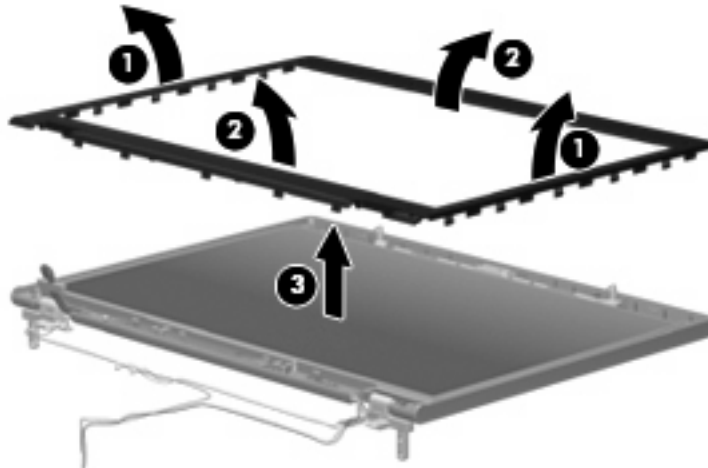

 **NOTE:** The display bezel is available using spare part number 446871-001.

10. Remove the four Torx T8M2.5×6.0 screws (1) that secure the display panel to the display enclosure.

11. Remove the display panel **(2)**.

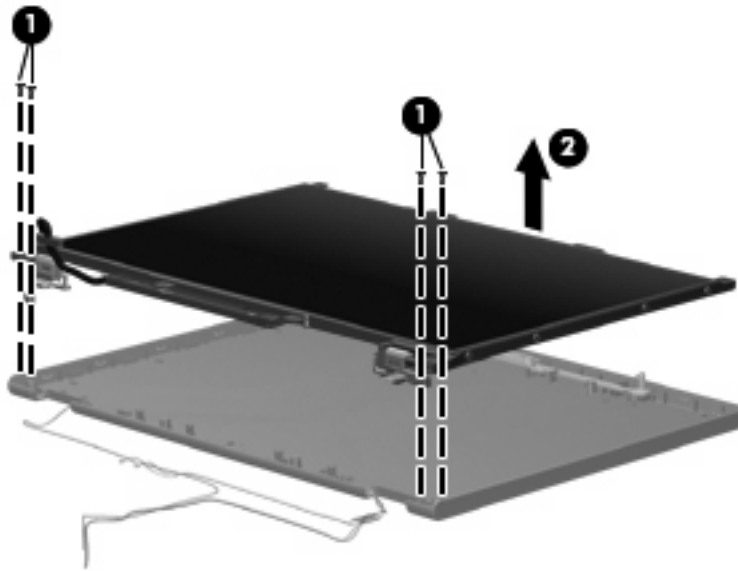

12. Remove the four Phillips PM2.0x3.0 screws **(1)** that secure each display hinge to the display panel.
13. Remove the display hinges **(2)**.

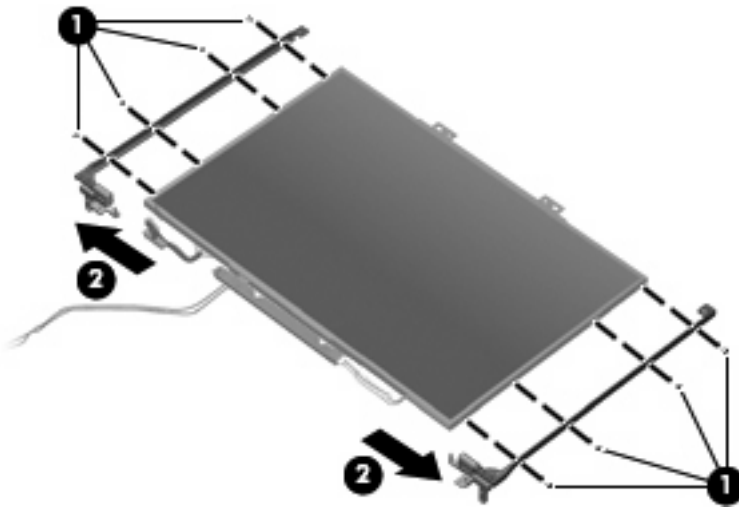

 **NOTE:** The left and right display hinges are available using spare part number 446882-001.

Reverse this procedure to reassemble and install the display assembly.

Top cover

Description	Spare part number
Top cover for use with HP Compaq 6715b and 6710b computer models (includes TouchPad and cable and fingerprint reader)	443823-001
Top cover for use with HP Compaq 6715s and 6710s computer models (includes TouchPad and cable)	443822-001

Before removing the top cover, follow these steps:

1. Shut down the computer. If you are unsure whether the computer is off or in Hibernation, turn the computer on, and then shut it down through the operating system.
2. Disconnect all external devices connected to the computer.
3. Disconnect the power from the computer by first unplugging the power cord from the AC outlet and then unplugging the AC adapter from the computer.
4. Remove the battery (see [Battery on page 48](#)).
5. Remove the following components:
 - a. Hard drive (see [Hard drive on page 52](#))
 - b. Memory/WLAN module compartment cover (see [Expansion memory module on page 56](#))
 - c. Optical drive (see [Optical drive on page 62](#))
 - d. Keyboard (see [Keyboard on page 64](#))
 - e. Switch cover (see [Switch cover on page 70](#))
 - f. Display assembly (see [Display assembly on page 76](#))

Remove the top cover:

1. Turn the computer upside down, with the rear panel toward you.
2. Remove the thirteen Torx T8M2.5×9.0 screws **(1)** that secure the top cover to the computer.

3. Remove the two HM5.0x9.0 screw locks **(2)** that secure the top cover to the computer.

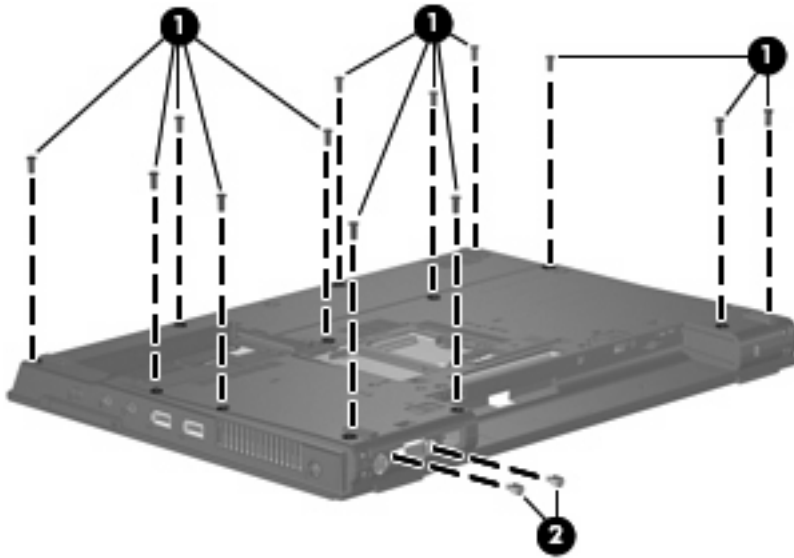

4. Turn the computer right-side up, with the front toward you.
5. Disconnect the TouchPad cable **(1)** from the system board.

 **NOTE:** Step 6 applies only to HP Compaq 6715b and 6710b computer models.

6. Disconnect the fingerprint reader board cable **(2)** from the system board.
7. Remove the microphone **(3)** from the clip built into the top cover and remove the microphone cable from the clips built into the top cover.

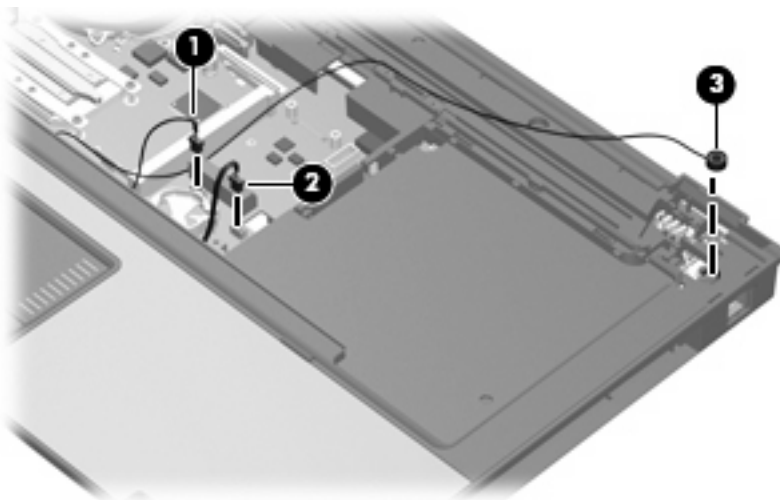

8. Remove the three Torx T8M2.5×9.0 screws that secure the top cover to the computer.

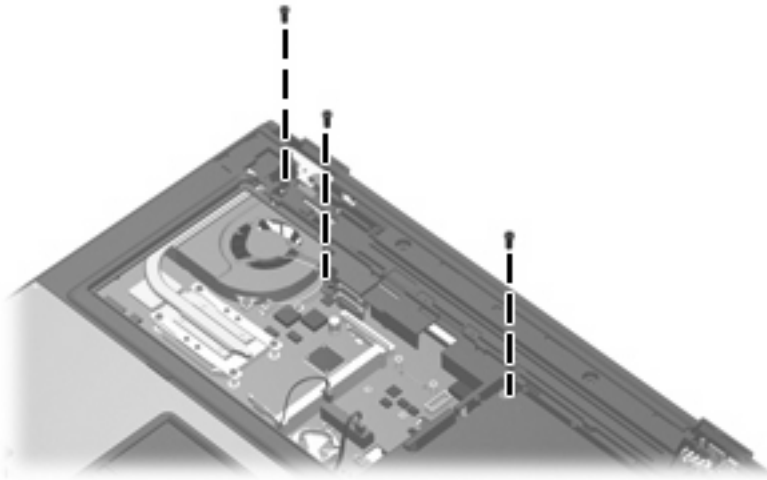

9. Lift the rear edge of the top cover **(1)** until it disengages from the base enclosure.
10. Swing the rear edge of the top cover **(2)** toward you until it rests at an angle.
11. Lift the top cover **(3)** straight up and remove it.

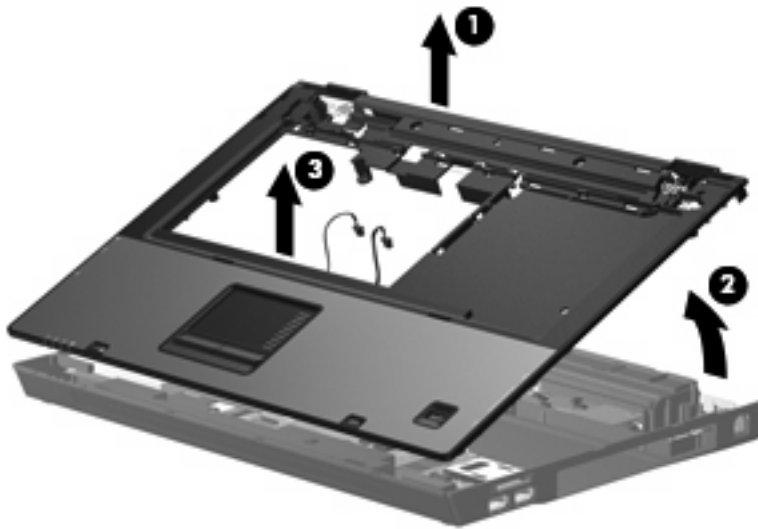

12. If it is necessary to replace the microphone and cable, disconnect the microphone cable **(1)** from the PC Card/audio board assembly and remove it.

 **NOTE:** The microphone is available in the Cable Kit, spare part number 443887-001.

13. If it is necessary to replace the Bluetooth module cable, disconnect the cable **(2)** from the system board and remove the cable from the opening **(3)** in the base enclosure.

 **NOTE:** The Bluetooth module cable is included with the Bluetooth module, spare part numbers 398393-002 (for use with all computer models in all countries and regions except Japan and Asia/Pacific) and 450066-001 (for use with all computer models in all countries and regions except Japan and Asia/Pacific), and is also available in the Cable Kit, spare part number 443887-001.

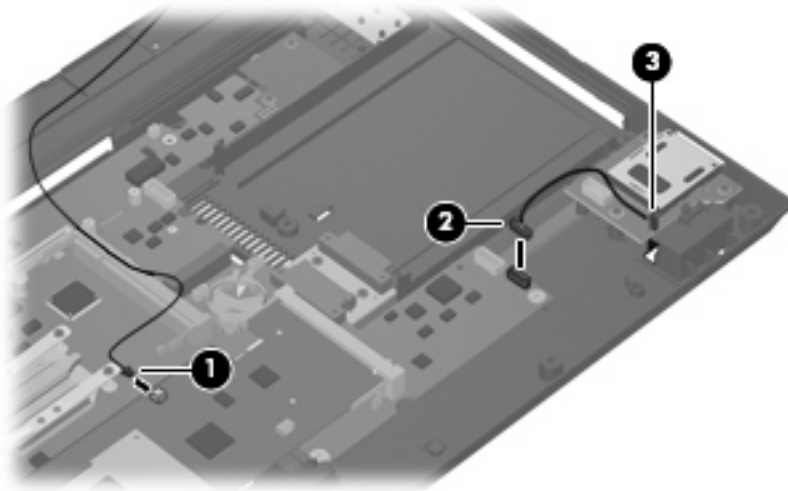

14. If it is necessary to replace the modem module cable, disconnect the cable **(1)** from the modem module and the system board **(2)**, and remove the modem connector **(3)** from the clip built into the base enclosure.

 **NOTE:** The modem module cable is available in the Cable Kit, spare part number 443887-001.

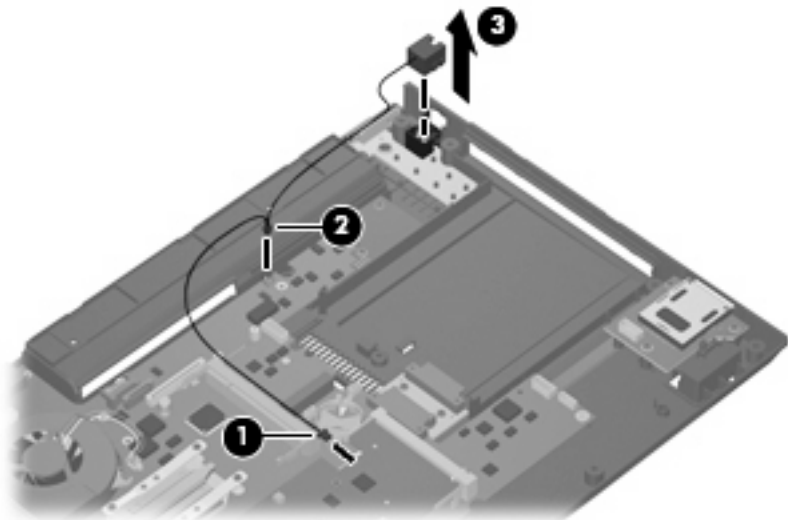

Reverse this procedure to install the top cover, microphone, Bluetooth module cable, and modem module cable.

Speaker assembly

Description	Spare part number
Speaker assembly	443821-001

Before removing the speaker assembly, follow these steps:

1. Shut down the computer. If you are unsure whether the computer is off or in Hibernation, turn the computer on, and then shut it down through the operating system.
2. Disconnect all external devices connected to the computer.
3. Disconnect the power from the computer by first unplugging the power cord from the AC outlet and then unplugging the AC adapter from the computer.
4. Remove the battery (see [Battery on page 48](#)).
5. Remove the following components:
 - a. Hard drive (see [Hard drive on page 52](#))
 - b. Memory/WLAN module compartment cover (see [Expansion memory module on page 56](#))
 - c. Optical drive (see [Optical drive on page 62](#))
 - d. Keyboard (see [Keyboard on page 64](#))
 - e. Switch cover (see [Switch cover on page 70](#))
 - f. Display assembly (see [Display assembly on page 76](#))
 - g. Top cover (see [Top cover on page 81](#))

Remove the speaker assembly:

1. Disconnect the speaker cable **(1)** from the PC Card/audio board assembly.
2. Remove the two Phillips PM2.5×5.0 screws **(2)** that secure the speaker assembly to the base enclosure.

3. Remove the speaker assembly (3).

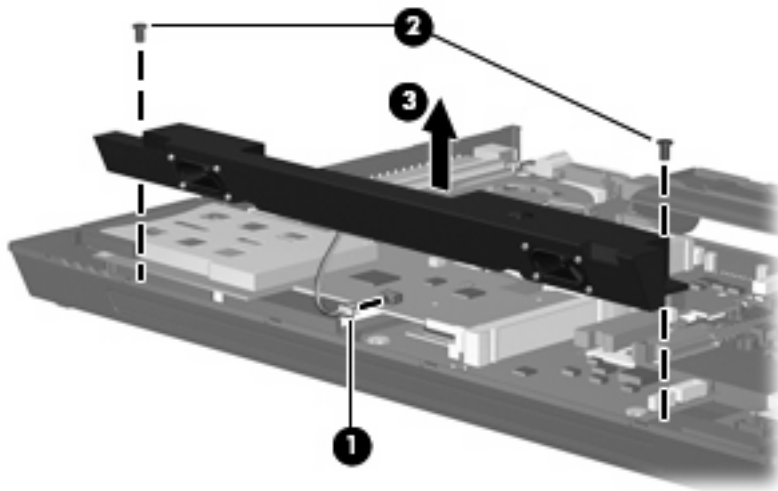

Reverse this procedure to install the speaker assembly.

USB/Media Card Reader board

 **NOTE:** This section applies only to HP Compaq 6715b and 6710b computer models.

Description	Spare part number
USB/Media Card Reader board (includes USB/Media Card Reader board cable)	443883-001

Before removing the USB/Media Card Reader board, follow these steps:

1. Shut down the computer. If you are unsure whether the computer is off or in Hibernation, turn the computer on, and then shut it down through the operating system.
2. Disconnect all external devices connected to the computer.
3. Disconnect the power from the computer by first unplugging the power cord from the AC outlet and then unplugging the AC adapter from the computer.
4. Remove the battery (see [Battery on page 48](#)).
5. Remove the following components:
 - a. Hard drive (see [Hard drive on page 52](#))
 - b. Memory/WLAN module compartment cover (see [Expansion memory module on page 56](#))
 - c. Optical drive (see [Optical drive on page 62](#))
 - d. Keyboard (see [Keyboard on page 64](#))
 - e. Switch cover (see [Switch cover on page 70](#))
 - f. Display assembly (see [Display assembly on page 76](#))
 - g. Top cover (see [Top cover on page 81](#))

Remove the USB/Media Card Reader board:

1. Disconnect the USB/Media Card Reader board cable **(1)** from the system board.
2. Remove the three Phillips PM2.5×5.0 screws **(2)** that secure the USB/Media Card Reader board to the computer.
3. Lift the USB/Media Card Reader board **(3)** straight up and remove it.

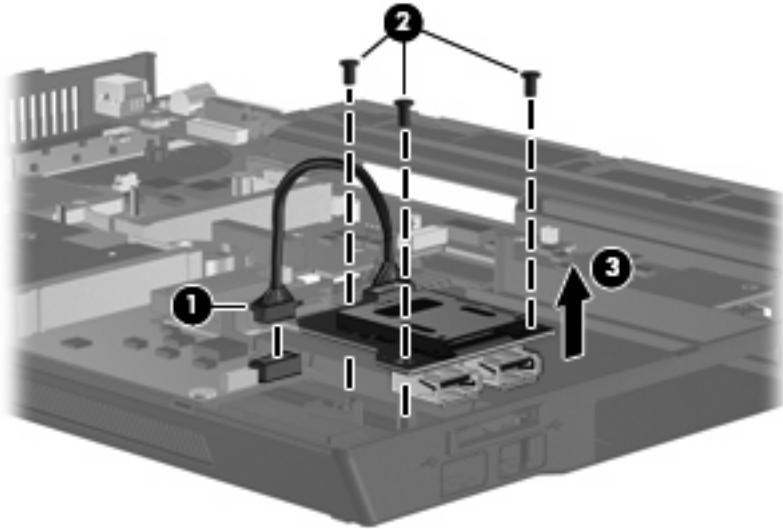

Reverse this procedure to install the USB/Media Card Reader board.

System board

Description	Spare part number
System board for use with HP Compaq 6715b computer models with WWAN capability (includes WWAN module slot)	443896-001
System board for use with HP Compaq 6715b computer models without WWAN capability (does not include WWAN module slot)	443898-001
System board for use with HP Compaq 6715s computer models	443897-001
System board for use with HP Compaq 6710b computer models with WWAN capability (includes WWAN module slot)	446905-001
System board for use with HP Compaq 6710b computer models without WWAN capability (does not include WWAN module slot)	446904-001
System board for use with HP Compaq 6710s computer models	446906-001

Before removing the system board, follow these steps:

1. Shut down the computer. If you are unsure whether the computer is off or in Hibernation, turn the computer on, and then shut it down through the operating system.
2. Disconnect all external devices connected to the computer.
3. Disconnect the power from the computer by first unplugging the power cord from the AC outlet and then unplugging the AC adapter from the computer.
4. Remove the battery (see [Battery on page 48](#)).
5. Remove the following components:
 - a. Hard drive (see [Hard drive on page 52](#))
 - b. Memory/WLAN module compartment cover (see [Expansion memory module on page 56](#))
 - c. Optical drive (see [Optical drive on page 62](#))
 - d. Keyboard (see [Keyboard on page 64](#))
 - e. Switch cover (see [Switch cover on page 70](#))
 - f. Fan (see [Fan on page 71](#))
 - g. Heat sink (see [Heat sink on page 72](#))
 - h. Display assembly (see [Display assembly on page 76](#))
 - i. Top cover (see [Top cover on page 81](#))

Remove the system board:

1. Press the PC Card eject button **(1)** twice. The first press releases the PC Card eject button from the PC Card slot. The second press releases the PC Card slot bezel from the PC Card slot. (The PC Card slot bezel is partially ejected from the PC Card slot.)

 **NOTE:** The PC Card slot bezel is included in the Plastics Kit, spare part number 443905-001.

2. Remove the PC Card slot bezel **(2)**.
3. Disconnect the USB/Media Card Reader board cable **(3)** from the system board.

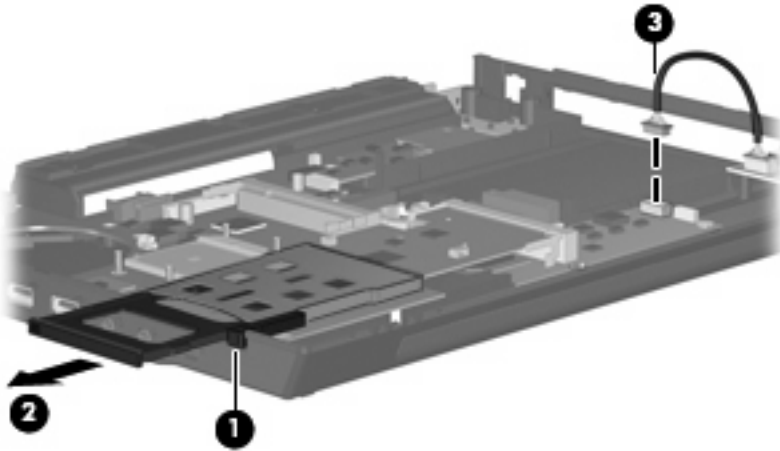

4. Remove the following screws:

(1) Two Phillips PM2.5×5.0 screws that secure the system board and PC Card/audio board assembly

(2) One Phillips PM2.5×5.0 screw that secures the system board

(3) Two Phillips PM2.5×5.0 screws that secure the optical drive connector board

(4) Two Phillips PM2.5×3.0 screws that secure the system board

 **NOTE:** If the computer is equipped with a WWAN module, another Phillips PM2.5×5.0 screw **(5)** that secures the SIM slot board must be removed.

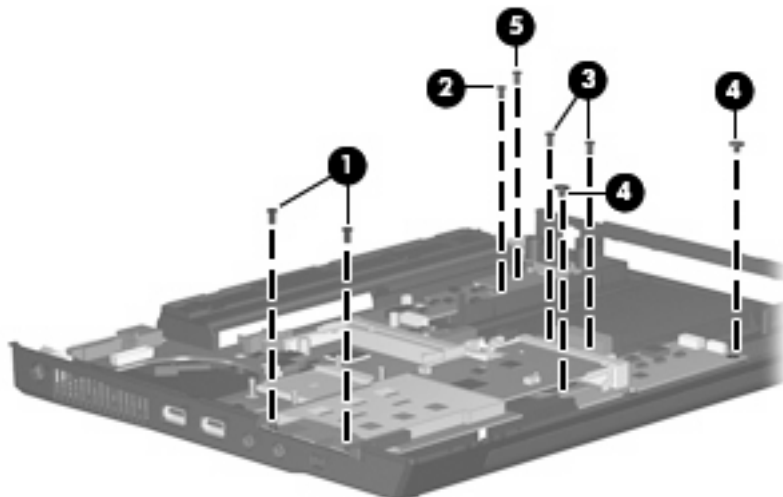

5. Use the right side of the system board **(1)** immediately behind the optical drive connector to lift the right side of the system board **(2)** until the rear left corner of the system board **(3)** clears the base enclosure.
6. Remove the system board **(4)** by pulling it away from the top cover at an angle until it clears the top cover.

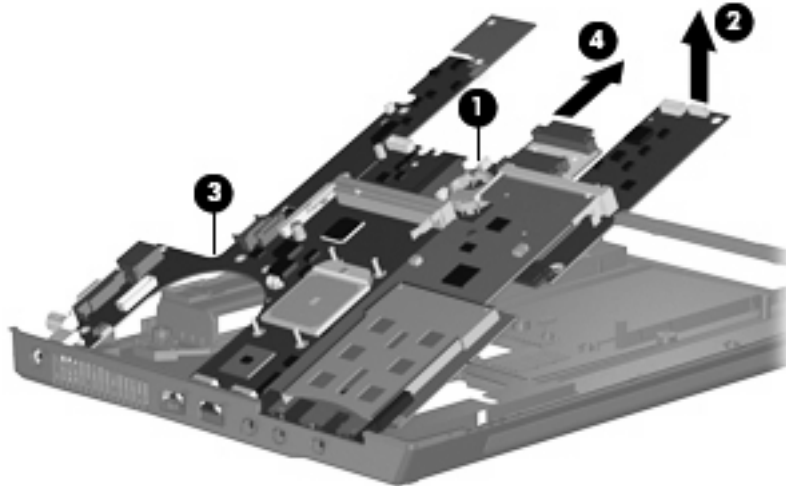

7. If it is necessary to replace the optical drive connector board, pull the board away from the system board until it disconnects from the system board.

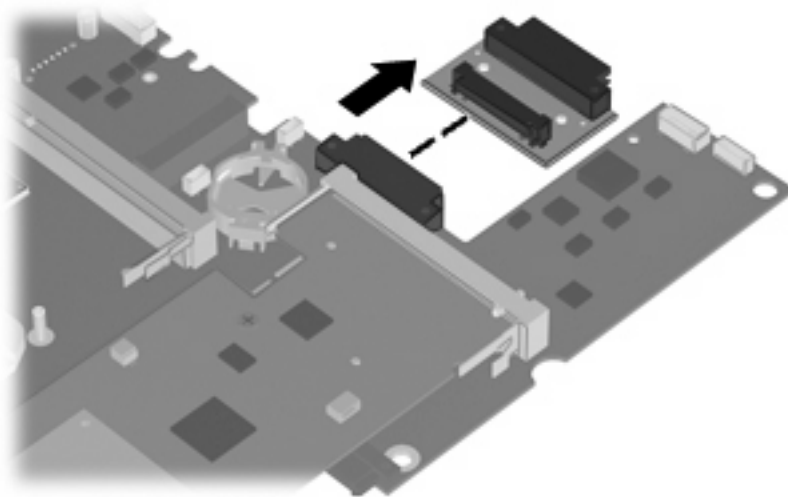

 **NOTE:** The optical drive connector board is available using spare part number 443820-001.

When replacing the system board, be sure that the following components are removed from the defective system board and installed on the replacement system board:

- SIM (see [SIM on page 49](#))
- Memory modules (see [Expansion memory module on page 56](#) and [Internal memory module on page 66](#))
- WLAN module (see [WLAN module on page 58](#))
- RTC battery (see [RTC battery on page 67](#))

- WWAN module (see [WWAN module on page 68](#))
- Processor (see [Processor on page 74](#))
- PC Card/audio board assembly (see [PC Card/audio board assembly on page 91](#))
- Modem module (see [Modem module on page 92](#))
- SIM slot board (see [SIM slot board on page 94](#))

Reverse the preceding procedure to install the system board.

PC Card/audio board assembly

Description	Spare part number
For use with HP Compaq 6715b and 6710b computer models	443889-001
For use with HP Compaq 6715s and 6710s computer models	443888-001

Before removing the PC Card/audio board assembly, follow these steps:

1. Shut down the computer. If you are unsure whether the computer is off or in Hibernation, turn the computer on, and then shut it down through the operating system.
2. Disconnect all external devices connected to the computer.
3. Disconnect the power from the computer by first unplugging the power cord from the AC outlet and then unplugging the AC adapter from the computer.
4. Remove the battery (see [Battery on page 48](#)).
5. Remove the following components:
 - a. Hard drive (see [Hard drive on page 52](#))
 - b. Memory/WLAN module compartment cover (see [Expansion memory module on page 56](#))
 - c. Optical drive (see [Optical drive on page 62](#))
 - d. Keyboard (see [Keyboard on page 64](#))
 - e. Switch cover (see [Switch cover on page 70](#))
 - f. Fan (see [Fan on page 71](#))
 - g. Heat sink (see [Heat sink on page 72](#))
 - h. Display assembly (see [Display assembly on page 76](#))
 - i. Top cover (see [Top cover on page 81](#))
 - j. System board (see [System board on page 88](#))

Remove the PC Card/audio board assembly:

1. Remove the Phillips PM2.5×5.0 screw **(1)** that secures the PC Card/audio board assembly to the system board.
2. Lift the left side of the PC Card/audio board assembly **(2)** until it disengages from the system board.
3. Remove the PC Card/audio board assembly **(3)** by pulling it away from the system board at an angle.

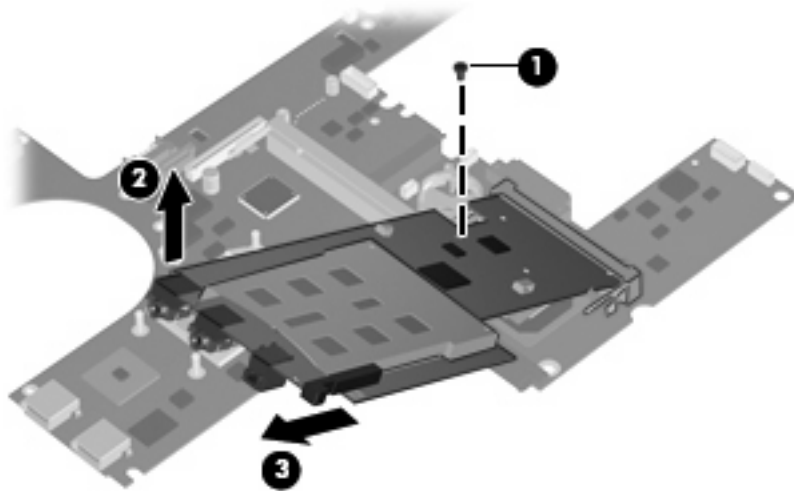

Reverse this procedure to install the PC Card/audio board assembly.

Modem module

 **NOTE:** All modem module spare part kits include a modem module cable.

Description	Spare part number
For use with HP Compaq 6715 computer models and with HP Compaq 6710 computer models in all countries and regions except Japan and Asia/Pacific	441074-001
For use with HP Compaq 6710 computer models in Japan and Asia/Pacific countries and regions	449139-001

Before removing the modem module, follow these steps:

1. Shut down the computer. If you are unsure whether the computer is off or in Hibernation, turn the computer on, and then shut it down through the operating system.
2. Disconnect all external devices connected to the computer.
3. Disconnect the power from the computer by first unplugging the power cord from the AC outlet and then unplugging the AC adapter from the computer.
4. Remove the battery (see [Battery on page 48](#)).
5. Remove the following components:
 - a. Hard drive (see [Hard drive on page 52](#))
 - b. Memory/WLAN module compartment cover (see [Expansion memory module on page 56](#))

- c. Optical drive (see [Optical drive on page 62](#))
- d. Keyboard (see [Keyboard on page 64](#))
- e. Switch cover (see [Switch cover on page 70](#))
- f. Fan (see [Fan on page 71](#))
- g. Heat sink (see [Heat sink on page 72](#))
- h. Display assembly (see [Display assembly on page 76](#))
- i. Top cover (see [Top cover on page 81](#))
- j. System board (see [System board on page 88](#))
- k. PC Card/audio board assembly (see [PC Card/audio board assembly on page 91](#))

Remove the modem module:

1. Turn the PC Card/audio board assembly upside down.
2. Remove the two Phillips PM2.5×3.0 screws **(1)** that secure the modem module to the PC Card/audio board assembly.
3. Lift the modem module **(2)** straight up and remove it.

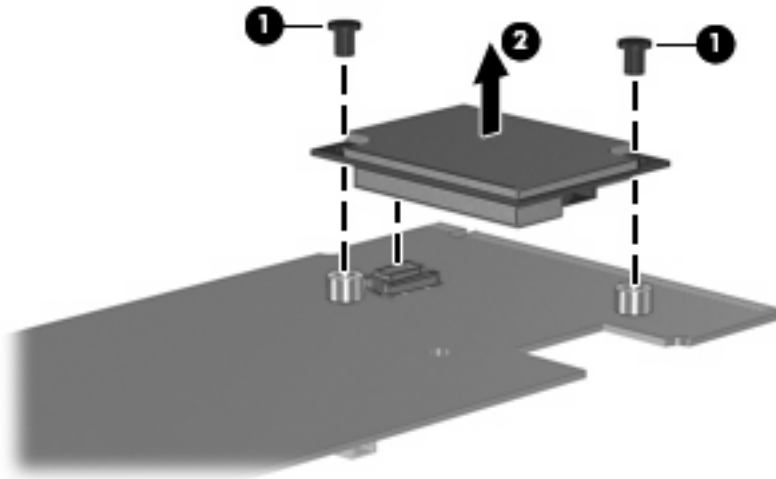

Reverse this procedure to install the modem module.

SIM slot board

 **NOTE:** This section applies only to HP Compaq 6715b and 6710b computer models with WWAN capability.

Description	Spare part number
SIM slot board	443907-001

Before removing the SIM slot board, follow these steps:

1. Shut down the computer. If you are unsure whether the computer is off or in Hibernation, turn the computer on, and then shut it down through the operating system.
2. Disconnect all external devices connected to the computer.
3. Disconnect the power from the computer by first unplugging the power cord from the AC outlet and then unplugging the AC adapter from the computer.
4. Remove the battery (see [Battery on page 48](#)).
5. Remove the following components:
 - a. Hard drive (see [Hard drive on page 52](#))
 - b. Memory/WLAN module compartment cover (see [Expansion memory module on page 56](#))
 - c. Optical drive (see [Optical drive on page 62](#))
 - d. Keyboard (see [Keyboard on page 64](#))
 - e. Switch cover (see [Switch cover on page 70](#))
 - f. Fan (see [Fan on page 71](#))
 - g. Heat sink (see [Heat sink on page 72](#))
 - h. Display assembly (see [Display assembly on page 76](#))
 - i. Top cover (see [Top cover on page 81](#))
 - j. System board (see [System board on page 88](#))

Remove the SIM slot board:

1. Turn the system board right-side up, with the front toward you.

2. Lift the SIM slot board **(1)** straight up and remove it, making note of the location of the pins **(2)** on the SIM slot board and their alignment with the system board.

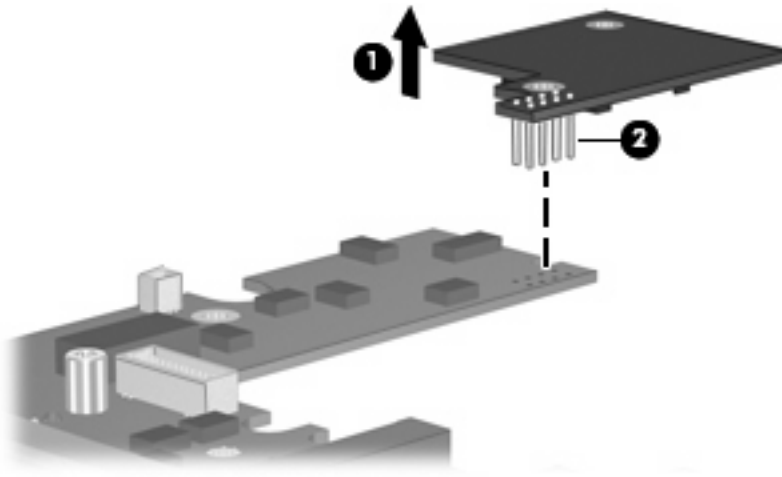

Reverse this procedure to install the SIM slot board.

5 Computer Setup

Starting Computer Setup

Computer Setup is a preinstalled, ROM-based utility that can be used even when the operating system is not working or will not load.

 **NOTE:** Some of the Computer Setup menu items listed in this guide may not be supported by your computer.

NOTE: Pointing devices are not supported in Computer Setup. You must use the keyboard to navigate and make selections.

NOTE: An external keyboard connected by USB can be used with Computer Setup only if USB legacy support is enabled.

To start Computer Setup:

1. Turn on or restart the computer.
2. Before Windows opens and while the “F10=ROM Based Setup” message is displayed in the lower-left corner of the screen, press **F10**.

Using Computer Setup

Navigating and selecting in Computer Setup

The information and settings in Computer Setup are accessed from the File, Security, Diagnostics, and System Configuration menus.

1. Open Computer Setup by turning on or restarting the computer, and then pressing **f10** while the "F10 = ROM Based Setup" message is displayed in the lower-left corner of the screen.

Because Computer Setup is not Windows-based, it does not support the TouchPad. Navigation and selection are by keystroke:

- To choose a menu or a menu item, use the arrow keys.
 - To select an item, press **enter**.
 - To close open dialog boxes and return to the main Computer Setup screen, press **esc**.
 - To view navigation information, press **f1**.
 - To change the language, press **f2**.
2. Select the **File, Security, Diagnostics,** or **System Configuration** menu.
 3. To exit Computer Setup, choose one of the following methods:
 - To exit Computer Setup without saving your preferences, use the arrow keys to select **File > Ignore Changes and Exit**. Then follow the instructions on the screen.
 - To save your preferences and exit Computer Setup, use the arrow keys to select **File > Save Changes and Exit**. Then follow the instructions on the screen.

Your preferences go into effect when the computer restarts.

Restoring factory settings in Computer Setup

To return all settings in Computer Setup to the values that were set at the factory, follow these steps:

1. Open Computer Setup by turning on or restarting the computer, and then pressing **f10** while the "F10 = ROM Based Setup" message is displayed in the lower-left corner of the screen.
2. Use the arrow keys to select File > Restore defaults, and then press **enter**.
3. When the confirmation dialog box opens, press **f10**.
4. To save your preferences and exit Computer Setup, use the arrow keys to select **File > Save Changes and Exit**. Then follow the instructions on the screen.

Your preferences go into effect when the computer restarts.



NOTE: Your password settings and security settings are not changed when you restore the factory settings.

Computer Setup menus

The menu tables in this section provide an overview of Computer Setup options.

 **NOTE:** Some of the Computer Setup menu items listed in this chapter may not be supported by your computer.

File menu

Select	To do this
System information	<ul style="list-style-type: none">• View identification information for the computer and the batteries in the system.• View specification information for the processor, cache and memory size, system ROM, video revision, and keyboard controller version.
Restore defaults	Replace the configuration settings in Computer Setup with the original factory settings. (Password settings and security settings are not changed when you restore the factory settings.)
Ignore changes and exit	Cancel any changes entered during the current session. Then exit and restart the computer.
Save changes and exit	Save any changes entered during the current session. Then exit and restart the computer. Your changes go into effect when the computer restarts.

Security menu

Select	To do this
Setup password	Enter, change, or delete a setup password.
Power-On password	Enter, change, or delete a power-on password.
Password options	<ul style="list-style-type: none">• Enable/disable stringent security.• Enable/disable password requirement on computer restart.
DriveLock passwords	<ul style="list-style-type: none">• Enable/disable DriveLock on any computer hard drive and on optional MultiBay hard drives.• Change a DriveLock user password or master password. <p>NOTE: DriveLock settings are accessible only when you enter Computer Setup by turning on (not restarting) the computer.</p>
Smart Card security	Enable/disable support for smart card and Java™ Card power-on authentication. <p>NOTE: Power-on authentication for smart cards is supported only on computers with optional smart card readers.</p> <p>NOTE: You must have an administrator password to change this setting.</p>
TPM Embedded Security	Enable/disable support for Trusted Platform Module (TPM) Embedded Security, which protects the computer from unauthorized access to owner functions available in Embedded Security for ProtectTools. For more information, refer to the ProtectTools Help. <p>NOTE: You must have a setup password to change this setting.</p>
System IDs	Enter user-defined computer asset tracking number and ownership tag.
Disk Sanitizer	Run Disk Sanitizer to destroy all existing data on the primary hard drive. The following options are available: <ul style="list-style-type: none">• Fast: Runs the Disk Sanitizer erase cycle once.• Optimum: Runs the Disk Sanitizer erase cycle 3 times.• Custom: Allows you to select the desired number of Disk Sanitizer erase cycles from a list. <p>CAUTION: If you run Disk Sanitizer, the data on the primary hard drive is destroyed permanently.</p>

Diagnostics menu

Select	To do this
Hard Drive Self-Test options	Run a comprehensive self-test on any hard drive in the system or on any optional MultiBay hard drive.
Memory Check	Run a comprehensive check on system memory.
Startup Check (select models only)	Verify the system components needed for starting the computer.

System Configuration menu

 **NOTE:** Some of the listed System Configuration options may not be supported by your computer.

Select	To do this
Language (or press f2)	Change the Computer Setup language.
Boot options	<ul style="list-style-type: none">• Set f9, f10, and f12 delay when starting up.• Enable/disable CD-ROM boot.• Enable/disable floppy boot.• Enable/disable internal network adapter boot and set the boot mode (PXE or RPL).• Enable/disable MultiBoot, which sets a boot order that can include most boot devices in the system.• Set the Express Boot Popup delay in seconds.• Set the boot order.
Device configurations	<ul style="list-style-type: none">• Swap the functions of the fn key and left ctrl key.• Enable/disable multiple standard pointing devices at startup. (To set the computer to support only a single, usually nonstandard, pointing device at startup, select Disable.)• Enable/disable USB legacy support. When enabled, USB legacy support allows the following:<ul style="list-style-type: none">◦ Use of a USB keyboard, mouse, and hub in Computer Setup even when a Windows operating system is not running.◦ Startup from bootable USB devices, including a hard drive, diskette drive, or optical drive connected by a USB port to the computer or to an optional docking device (select models only).• Select a parallel port mode: EPP (Enhanced Parallel Port), standard, bidirectional, or ECP (Enhanced Capabilities Port).• Enable/disable BIOS DMA data transfers.• Enable/disable fan always on while connected to an AC outlet.• Enable/disable Intel® Data Execution Prevention or AMD® PSAA Execution Disable. When enabled, the processor can disable some virus code execution, which helps to improve computer security.• Enable/disable LAN Power Save. When enabled, saves power by turning off the LAN when not in use.• Enable/disable SATA Native Mode.• Enable/disable Dual Core CPU.• Enable/disable Secondary Battery Fast Charge.• Choose Bit-shift or LBA assisted HDD Translation Mode.• Enable/disable Windows direct application launcher.• Enable/disable HP Lockout.

Select	To do this
Built-In Device Options	<ul style="list-style-type: none"> • Enable/disable embedded WWAN Device Radio. • Enable/disable embedded WLAN Device Radio. • Enable/disable embedded Bluetooth® Device Radio. • Enable/disable LAN/WLAN Switching. When enabled, switches to a WLAN when a LAN is either unavailable or disconnected. • Enable/disable Wake on LAN from Off. • Enable/disable the ambient light sensor.
Port Options	<ul style="list-style-type: none"> • Enable/disable the serial port. • Enable/disable the parallel port. • Enable/disable the flash media reader. • Enable/disable the USB port. CAUTION: Disabling the USB port also disables MultiBay devices and ExpressCard devices on the advanced port replicator. • Enable/disable the 1394 port. • Enable/disable the cardbus slot. • Enable/disable the ExpressCard slot. • Enable/disable the infrared port. • Enable/disable the optical disk drive. • Enable/disable the network controller.

6 Specifications

Computer specifications

	Metric	U.S.
Dimensions		
Height (front to back)	3.49 to 4.05 cm	1.37 to 1.59 in
Width	35.7 cm	14.05 in
Depth	26.5 cm	10.43 in
Weight (with optical drive, hard drive, and battery)	2.75 kg	6.06 lbs
Input power		
Operating voltage	19.0 V dc @ 4.74 A – 90 W	
Operating current	4.74 A	
Temperature		
Operating (not writing to optical disc)	0°C to 35°C	32°F to 95°F
Operating (writing to optical disc)	5°C to 35°C	41°F to 95°F
Nonoperating	-20°C to 60°C	-4°F to 140°F
Relative humidity		
Operating	10% to 90%	
Nonoperating	5% to 95%	
Maximum altitude (unpressurized)		
Operating (14.7 to 10.1 psia)	-15 m to 3,048 m	-50 ft to 10,000 ft
Nonoperating (14.7 to 4.4 psia)	-15 m to 12,192 m	-50 ft to 40,000 ft
Shock		
Operating	125 g, 2 ms, half-sine	
Nonoperating	200 g, 2 ms, half-sine	
Random vibration		
Operating	0.75 g zero-to-peak, 10 Hz to 500 Hz, 0.25 oct/min sweep rate	

	Metric	U.S.
Nonoperating	1.50 g zero-to-peak, 10 Hz to 500 Hz, 0.5 oct/min sweep rate	
NOTE: Applicable product safety standards specify thermal limits for plastic surfaces. The computer operates well within this range of temperatures.		

15.4-inch, WSXGA display specifications

	Metric	U.S.
Dimensions		
Height	20.7 cm	8.15 in
Width	33.1 cm	13.03 in
Diagonal	39.1 cm	15.39 in
Number of colors	Up to 16.8 million	
Contrast ratio	200:1 (typical)	
Brightness	180 nits (typical)	
Pixel resolution		
Pitch	0.197 × 0.197 mm	
Format	1680 × 1050	
Configuration	RGB vertical stripe	
Backlight	CCFT	
Character display	80 × 25	
Total power consumption	7.0 W	
Viewing angle	+/-40° horizontal, +/-50° vertical (typical)	

15.4-inch, WXGA display specifications

	Metric	U.S.
Dimensions		
Height	20.7 cm	8.15 in
Width	33.1 cm	13.03 in
Diagonal	39.1 cm	15.39 in
Number of colors	Up to 16.8 million	
Contrast ratio	200:1 (typical)	
Brightness	180 nits (typical)	
Pixel resolution		
Pitch	0.259 × 0.259 mm	
Format	1440 × 900	
Configuration	RGB vertical stripe	
Backlight	CCFT	
Character display	80 × 25	
Total power consumption	6.5 W	
Viewing angle	+/-45° horizontal, +15/-35° vertical (typical)	

Hard drive specifications

	160-GB*	120-GB*	80-GB*
Dimensions			
Height	9.5 mm	9.5 mm	9.5 mm
Width	70 mm	70 mm	70 mm
Weight	101 g	101 g	101 g
Interface type			
	SATA	SATA	SATA
Transfer rate			
	100 MB/sec	100 MB/sec	100 MB/sec
Security			
	ATA security	ATA security	ATA security
Seek times (typical read, including setting)			
Single track	3 ms	3 ms	3 ms
Average	13 ms	13 ms	13 ms
Maximum	24 ms	24 ms	24 ms
Logical blocks			
	312,560,640	234,420,480	156,280,320
Disc rotational speed			
	5400 rpm	5400 rpm	7200 and 5400 rpm
Operating temperature			
	5°C to 55°C (41°F to 131°F)		
*1 GB = 1 billion bytes when referring to hard drive storage capacity. Actual accessible capacity is less. Actual drive specifications may differ slightly.			
NOTE: Certain restrictions and exclusions apply. Contact technical support for details.			

Primary 6-cell, Li-ion battery specifications

	Metric	U.S.
Dimensions		
Height	2.0 cm	0.79 in
Width	20.3 cm	7.99 in
Depth	5.3 cm	2.09 in
Weight	0.34 kg	0.75 lb
Energy		
Voltage	14.4 V	
Amp-hour capacity	2.2 Ah and 2.55 Ah	
Watt-hour capacity	47 Wh and 55Wh	
Temperature		
Operating	5°C to 45°C	41°F to 113°F
Nonoperating	0°C to 60°C	32°F to 140°F

DVD±RW and CD-RW Super Multi Double-Layer Combo Drive specifications

Applicable disc	Read:	Write:
	CD-DA, CD+(E)G, CD-MIDI, CD-TEXT, CD-ROM, CD-ROM XA, MIXED MODE CD, CD-I, CD-I Bridge (Photo-CD, Video CD), Multisession CD (Photo-CD, CD-EXTRA, Portfolio, CD-R, CD-RW), CD-R, CD-RW, DVD-ROM (DVD-5, DVD-9, DVD-10, DVD-18), DVD-R, DVD-RW, DVD+R, DVD+RW, DVD-RAM	CD-R and CD-RW DVD+R, DVD+RW, DVD-R, DVD-RW, DVD-RAM
Center hole diameter	1.5 cm (0.59 in)	
Disc diameter		
Standard disc	12 cm (4.72 in)	
Mini disc	8 cm (3.15 in)	
Disc thickness	1.2 mm (0.047 in)	
Track pitch	0.74 μ m	
Access time	CD	DVD
Random	< 175 ms	< 230 ms
Full stroke	< 285 ms	< 335 ms
Audio output level	Line-out, 0.7 Vrms	
Cache buffer	2 MB	
Data transfer rate		
24X CD-ROM	3,600 KB/sec	
8X DVD-ROM	10,800 KB/sec	
24X CD-R	3,600 KB/sec	
16X CD-RW	2,400 KB/sec	
8X DVD+R	10,800 KB/sec	
4X DVD+RW	5,400 KB/sec	
8X DVD-R	10,800 KB/sec	
4X DVD-RW	5,400 KB/sec	
2.4X DVD+R(9)	2,700 KB/sec	
5X DVD-RAM	6,750 KB/sec	
Transfer mode	Multiword DMA Mode	
Startup time	< 15 seconds	
Stop time	< 6 seconds	

DVD/CD-RW Combo Drive specifications

Applicable disc	Read: CD-DA, CD+(E)G, CD-MIDI, CD-TEXT, CD-ROM, CD-ROM XA, MIXED MODE CD, CD-I, CD-I Bridge (Photo-CD, Video CD), Multisession CD (Photo-CD, CD-EXTRA, Portfolio, CD-R, CD-RW), CD-R, CD-RW, DVD-ROM (DVD-5, DVD-9, DVD-10, DVD-18), DVD-R, DVD-RW, DVD+R, DVD+RW, DVD-RAM	Write: CD-R and CD-RW
Center hole diameter	1.5 cm (0.59 in)	
Disc diameter		
Standard disc	12 cm (4.72 in)	
Mini disc	8 cm (3.15 in)	
Disc thickness	1.2 mm (0.047 in)	
Track pitch	0.74 μ m	
Access time	CD	DVD
Random	< 110 ms	< 130 ms
Full stroke	< 210 ms	< 225 ms
Audio output level	Line-out, 0.7 Vrms	
Cache buffer	2 MB	
Data transfer rate		
24X CD-ROM	3,600 KB/sec	
8X DVD	3,600 KB/sec	
24X CD-R	3,600 KB/sec	
24X CD-RW	3,600 KB/sec	
Transfer mode	Multiword DMA mode 2	
Startup time	< 15 seconds	
Stop time	< 6 seconds	

DVD-ROM drive

Applicable disc	DVD-ROM (DVD-5, DVD-9, DVD-10, DVD-18, CD-ROM (Mode 1 and 2), CD Digital Audio, CD-XA ready (Mode 2, Form 1 and Form 2), CD-I (Mode 2, Form 1 and Form 2), CD-R, CD-RW, Photo CD (single and multisession), CD-Bridge	
Center hole diameter	1.5 cm (0.59 in)	
Disc diameter		
Standard disc	12 cm (4.72 in)	
Mini disc	8 cm (3.15 in)	
Disc thickness	1.2 mm (0.047 in)	
Track pitch	0.74 μm	
Access time	CD	DVD
Random	< 100 ms	< 125 ms
Full stroke	< 175 ms	< 225 ms
Audio output level	Line-out, 0.7 Vrms	
Cache buffer	512 KB	
Data transfer rate		
CD-R (24X)	3600 KB/s (150 KB/s at 1X CD rate)	
CD-RW (10X)	1500 KB/s (150 KB/s at 1X CD rate)	
CD-ROM (24X)	3600 KB/s (150 KB/s at 1X CD rate)	
DVD (8X)	10,800 KB/s (1,352 KB/s at 1X DVD rate)	
Multiword DMA mode 2	16.6 MB/s	
Startup time	< 10 seconds	
Stop time	< 3 seconds	

System DMA specifications

Hardware DMA	System function
DMA0	Not applicable
DMA1*	Not applicable
DMA2*	Not applicable
DMA3	Not applicable
DMA4	Direct memory access controller
DMA5*	Available for PC Card
DMA6	Not assigned
DMA7	Not assigned

*PC Card controller can use DMA 1, 2, or 5.

System interrupt specifications

Hardware IRQ	System function
IRQ0	System timer
IRQ1	Standard 101-/102-Key or Microsoft® Natural Keyboard
IRQ2	Cascaded
IRQ3	Intel 82801DB/DBM USB2 Enhanced Host Controller—24CD
IRQ4	COM1
IRQ5*	Conexant AC—Link Audio Intel 82801DB/DBM SMBus Controller—24C3 Data Fax Modem with SmartCP
IRQ6	Diskette drive
IRQ7*	Parallel port
IRQ8	System CMOS/real-time clock
IRQ9*	Microsoft ACPI-compliant system
IRQ10*	Intel USB UHCI controller—24C2 Intel 82852/82855 GM/GME Graphic Controller Realtek RTL8139 Family PCI Fast Ethernet Controller
IRQ11	Intel USB EHCI controller—24CD Intel USB UHCI controller—24C4 Intel USB UHCI controller—24C7 Intel Pro/Wireless 2200BG TI OHCI 1394 host controller TI PCI1410 CardBus controller
IRQ12	Synaptics PS/2 TouchPad
IRQ13	Numeric data processor
IRQ14	Primary IDE channel
IRQ15	Secondary IDE channel

*Default configuration; audio possible configurations are IRQ5, IRQ7, IRQ9, IRQ10, or none.

NOTE: PC Cards may assert IRQ3, IRQ4, IRQ5, IRQ7, IRQ9, IRQ10, IRQ11, or IRQ15. Either the infrared or the serial port may assert IRQ3 or IRQ4.

System I/O address specifications

I/O address (hex)	System function (shipping configuration)
000 - 00F	DMA controller no. 1
010 - 01F	Unused
020 - 021	Interrupt controller no. 1
022 - 024	Opti chipset configuration registers
025 - 03F	Unused
02E - 02F	87334 "Super I/O" configuration for CPU
040 - 05F	Counter/timer registers
044 - 05F	Unused
060	Keyboard controller
061	Port B
062 - 063	Unused
064	Keyboard controller
065 - 06F	Unused
070 - 071	NMI enable/RTC
072 - 07F	Unused
080 - 08F	DMA page registers
090 - 091	Unused
092	Port A
093 - 09F	Unused
0A0 - 0A1	Interrupt controller no. 2
I/O Address (hex)	System Function (shipping configuration)
0A2 - 0BF	Unused
0C0 - 0DF	DMA controller no. 2
0E0 - 0EF	Unused
0F0 - 0F1	Coprocessor busy clear/reset
0F2 - 0FF	Unused
100 - 16F	Unused
170 - 177	Secondary fixed disk controller
178 - 1EF	Unused
1F0 - 1F7	Primary fixed disk controller
1F8 - 200	Unused
201	JoyStick (decoded in ESS1688)
202 - 21F	Unused

I/O address (hex)	System function (shipping configuration)
220 - 22F	Entertainment audio
230 - 26D	Unused
26E - 26	Unused
278 - 27F	Unused
280 - 2AB	Unused
2A0 - 2A7	Unused
2A8 - 2E7	Unused
2E8 - 2EF	Reserved serial port
2F0 - 2F7	Unused
2F8 - 2FF	Infrared port
300 - 31F	Unused
320 - 36F	Unused
370 - 377	Secondary diskette drive controller
378 - 37F	Parallel port (LPT1/default)
380 - 387	Unused
388 - 38B	FM synthesizer—OPL3
38C - 3AF	Unused
3B0 - 3BB	VGA
3BC - 3BF	Reserved (parallel port/no EPP support)
3C0 - 3DF	VGA
3E0 - 3E1	PC Card controller in CPU
3E2 - 3E3	Unused
3E8 - 3EF	Internal modem
3F0 - 3F7	"A" diskette controller
3F8 - 3FF	Serial port (COM1/default)
CF8 - CFB	PCI configuration index register (PCIDIVO-1)
CFC - CFF	PCI configuration data register (PCIDIVO-1)

System memory map specifications

Size	Memory address	System function
640 KB	00000000-0009FFFF	Base memory
128 KB	000A0000-000BFFFF	Video memory
48 KB	000C0000-000CBFFF	Video BIOS
160 KB	000C8000-000E7FFF	Unused
64 KB	000E8000-000FFFFF	System BIOS
15 MB	00100000-00FFFFFF	Extended memory
58 MB	04800000-07FFFFFF	Super extended memory
58 MB	04800000-07FFFFFF	Unused
2 MB	08000000-080FFFFF	Video memory (direct access)
4 GB	08200000-FFFFFF	Unused
64 KB	FFFF0000-FFFFFFFF	System BIOS

7 Screw listing

This section provides specification and reference information for the screws and screw locks used in the computer. All screws and screw locks listed in this section are available in the Screw Kit, spare part number 443906-001.

Torx T8M2.5×7.0 screw

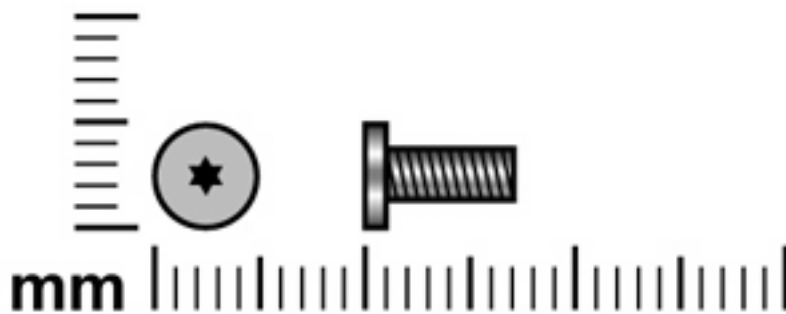

Color	Quantity	Length	Thread	Head diameter
Black	2	7.0 mm	2.5 mm	5.0 mm

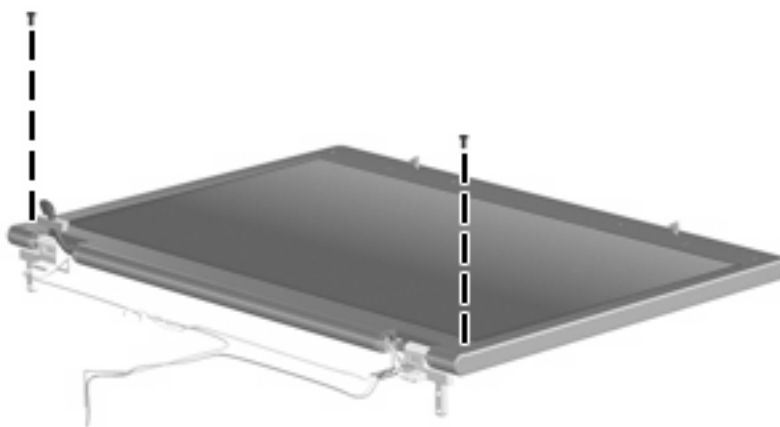

Where used: 2 screws that secure the bottom edge of the display bezel to the display assembly

Phillips PM2.0×5.0 captive screw

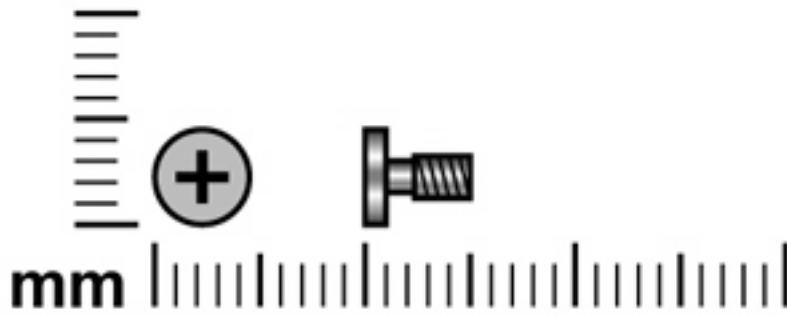

Color	Quantity	Length	Thread	Head diameter
Black	4	5.0 mm	2.0mm	5.0 mm

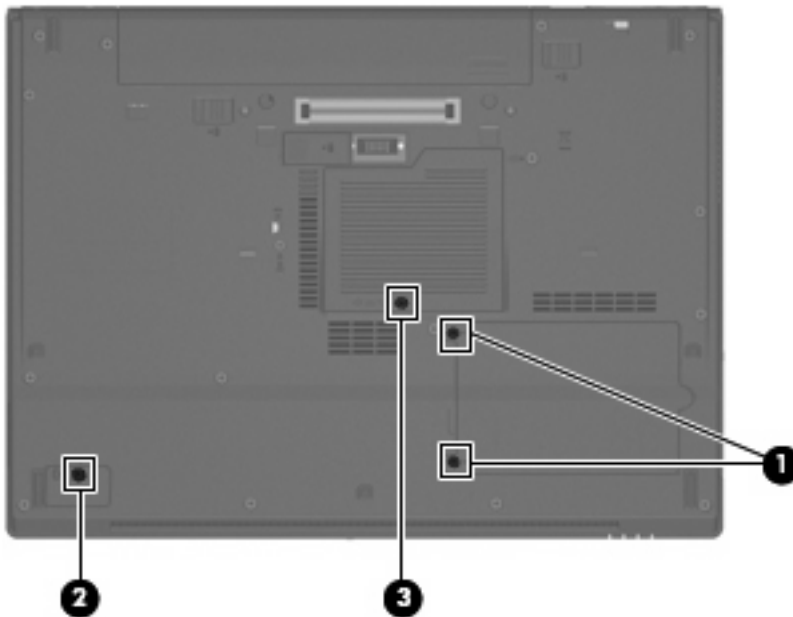

Where used:

- (1) Two screws that secure the hard drive cover to the computer (screws are captured on the cover by C-clips)
- (2) One screw that secures the Bluetooth module cover to the computer (screw is captured on the cover by a C-clip)
- (3) One screw that secures the memory/WLAN module compartment cover to the computer (screw is captured on the cover by a C-clip)

Phillips PM2.5×13.0 captive screw

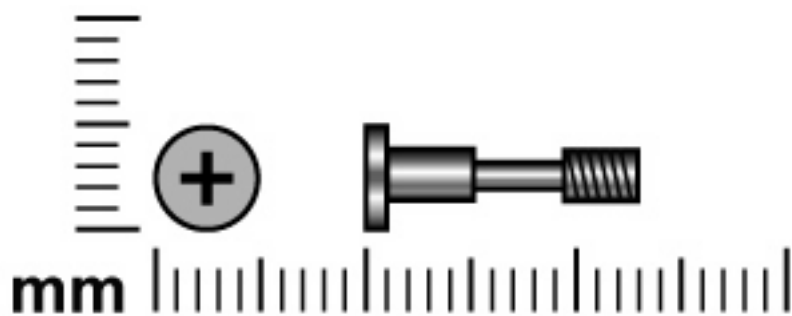

Color	Quantity	Length	Thread	Head diameter
Black	1	13.0 mm	2.5 mm	6.0 mm

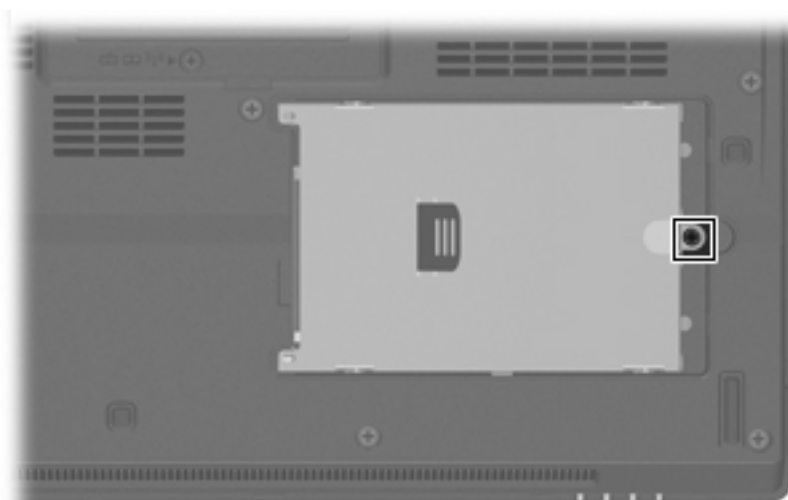

Where used: One screw that secures the hard drive to the computer

Phillips PM3.0×3.0 screw

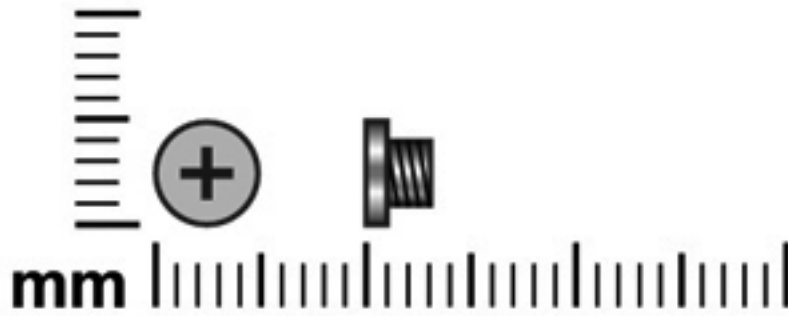

Color	Quantity	Length	Thread	Head diameter
Silver	4	3.0 mm	3.0 mm	5.0 mm



Where used: 4 screws that secure the hard drive bracket to the hard drive

Phillips PM2.5×3.0 screw

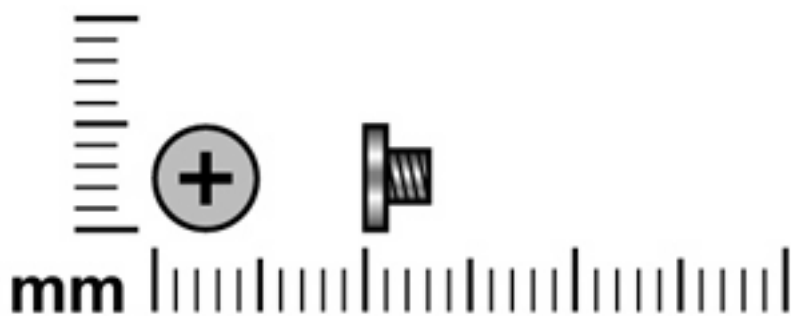

Color	Quantity	Length	Thread	Head diameter
Black	6	3.0 mm	2.5 mm	5.0 mm

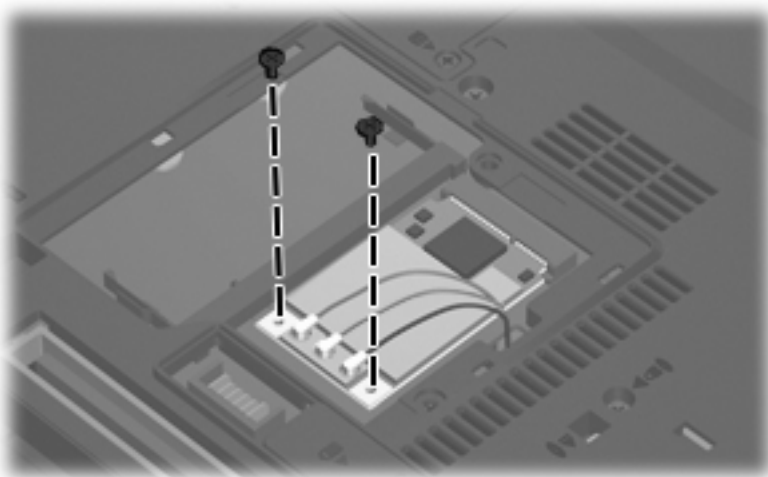

Where used: 2 screws that secure the WLAN module to the computer

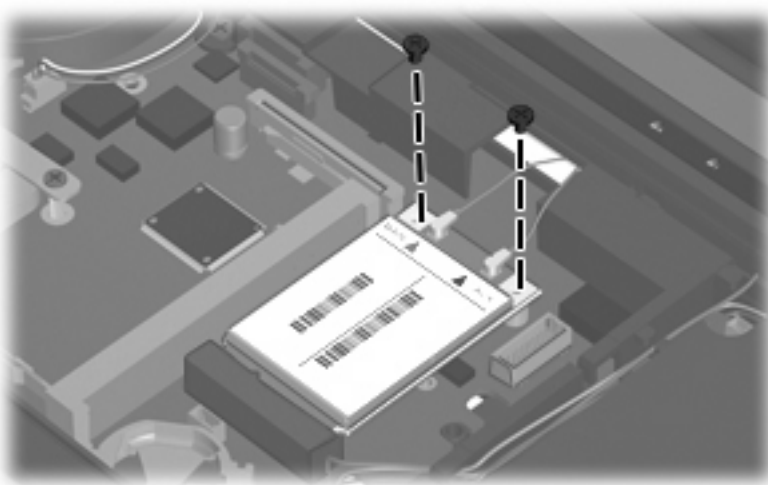

Where used: 2 screws that secure the WWAN module to the computer

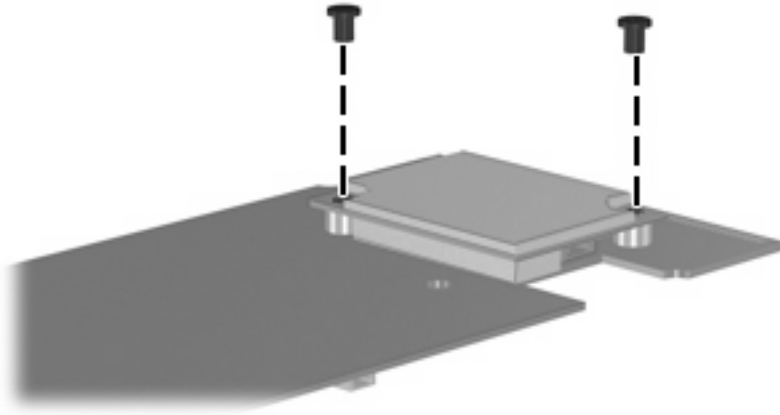

Where used: 2 screws that secure the modem module to the PC Card/audio board assembly

Torx T8M2.5×9.0 screw

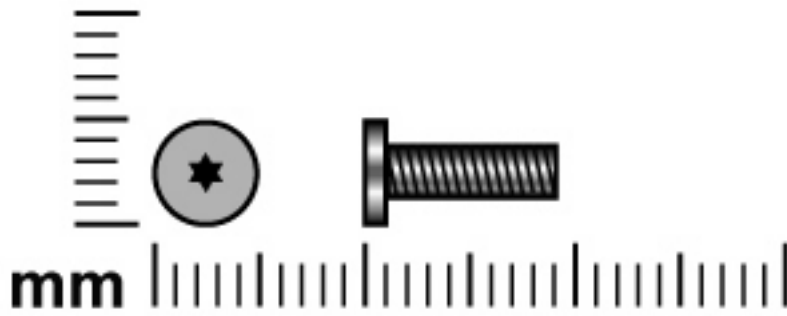

Color	Quantity	Length	Thread	Head diameter
Black	23	9.0 mm	2.5 mm	5.0 mm

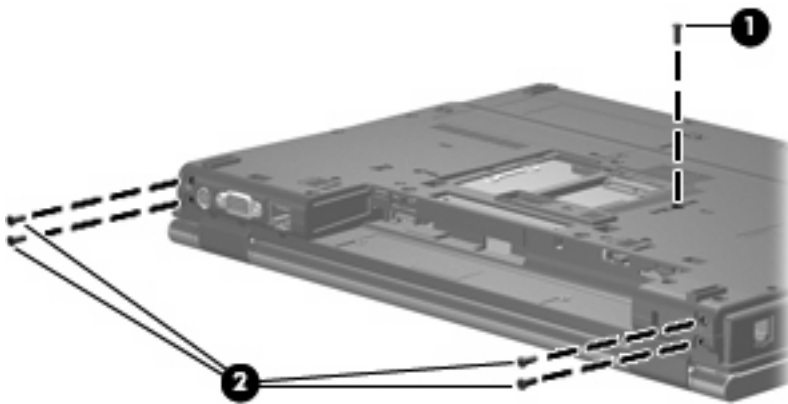

Where used:

- (1) One screw that secures the optical drive to the computer
- (2) Four screws that secure the display assembly to the computer

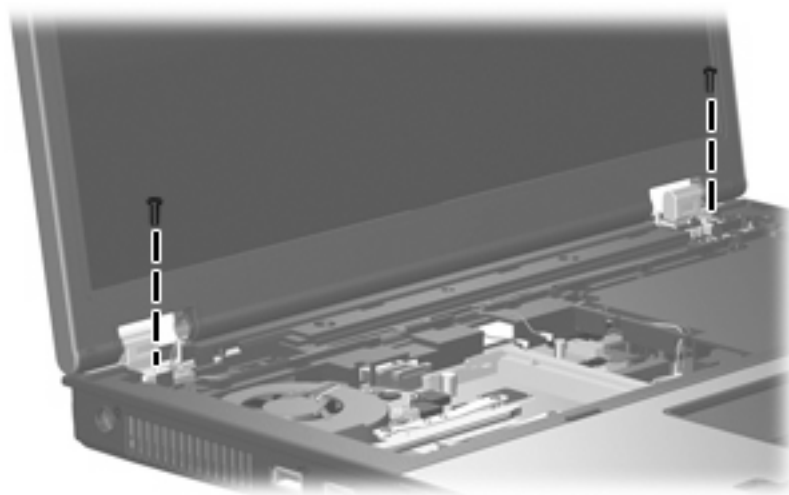

Where used: 2 screws that secure the display assembly to the computer

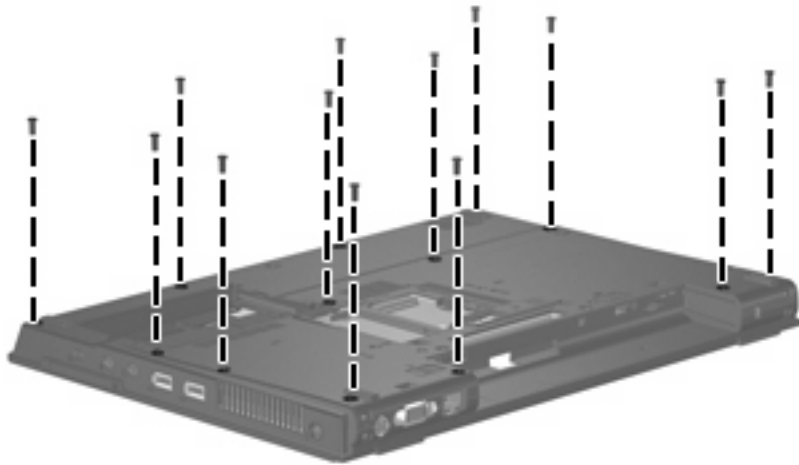

Where used: 13 screws that secure the top cover to the computer

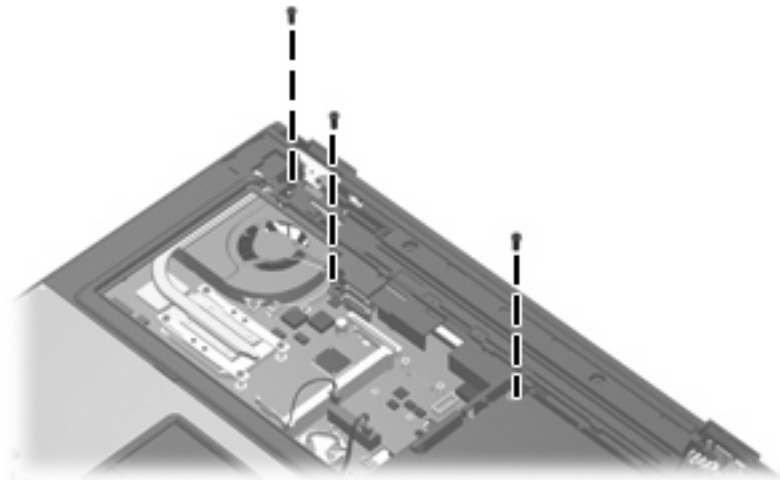

Where used: 3 screws that secure the top cover to the computer

Phillips PM2.0x3.0 screw

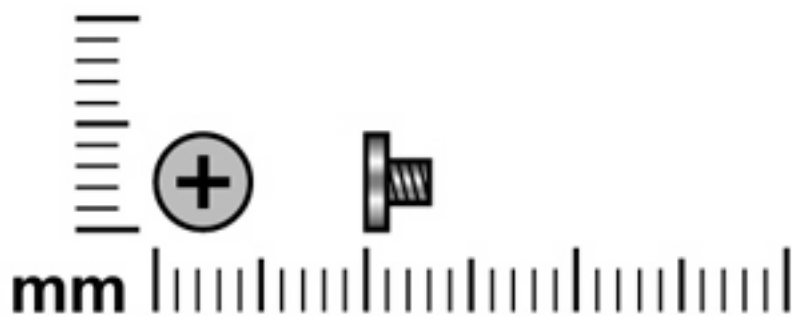

Color	Quantity	Length	Thread	Head diameter
Black	10	3.0 mm	2.0 mm	4.5 mm



Where used: 2 screws that secure the optical drive bracket to the optical drive

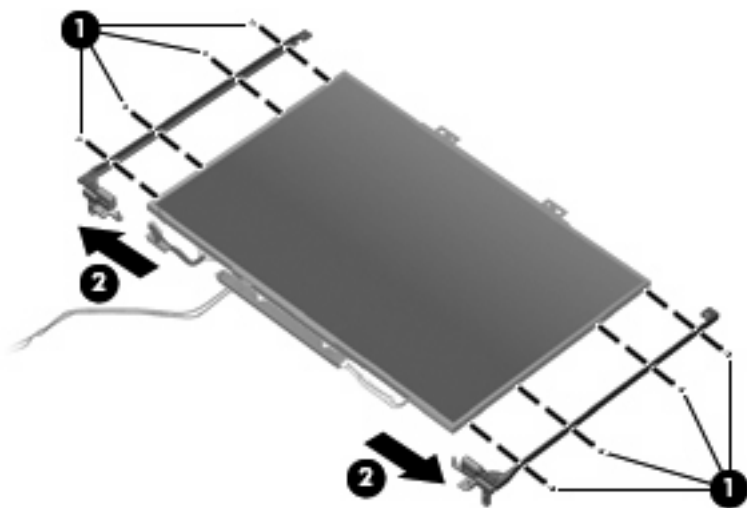

Where used: 8 screws that secure the display hinges to the display panel

Black Phillips PM2.5×8.0 captive screw

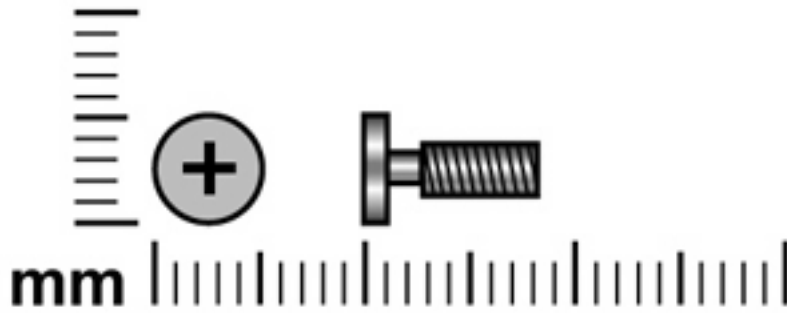

Color	Quantity	Length	Thread	Head diameter
Black	3	8.0 mm	2.5 mm	5.0 mm

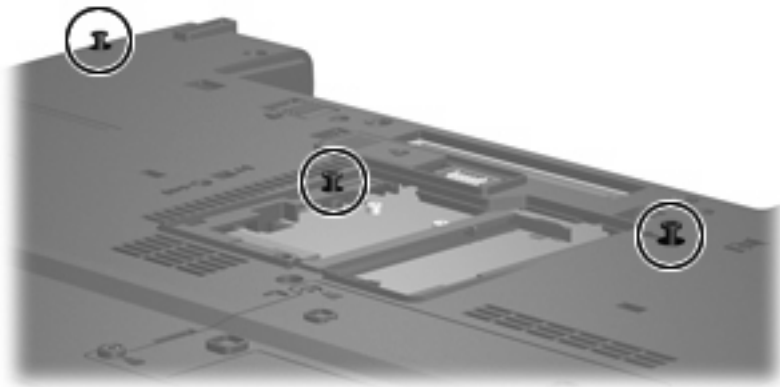

Where used: 3 screws that secure the keyboard to the computer

Silver Phillips PM2.5×8.0 captive screw

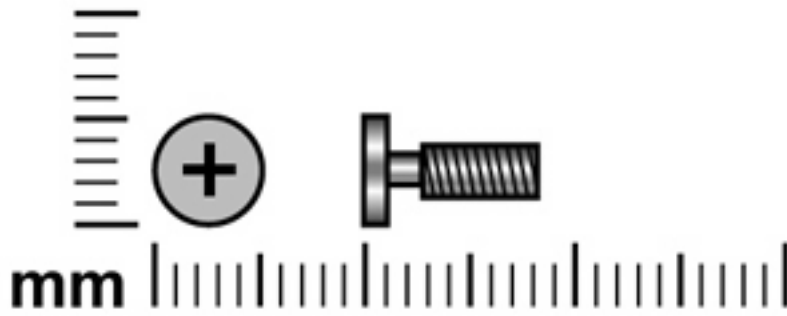

Color	Quantity	Length	Thread	Head diameter
Silver	1	8.0 mm	2.5 mm	5.0 mm

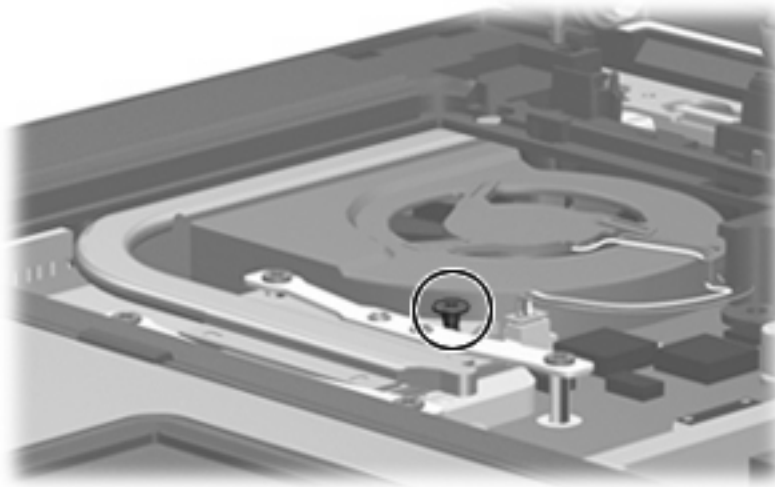

Where used: One captive screw that secures the fan to the computer

Phillips PM2.5×8.0 screw

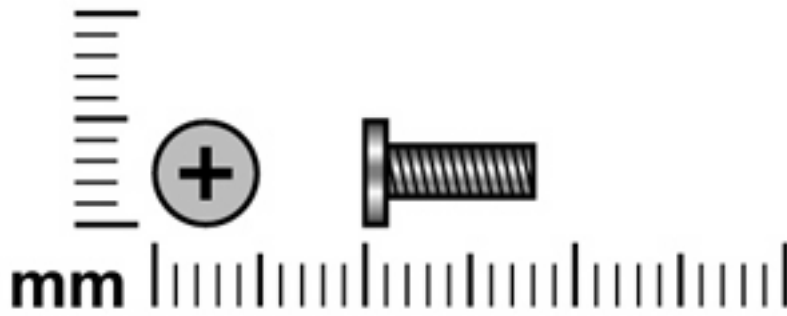

Color	Quantity	Length	Thread	Head diameter
Black	1	8.0 mm	2.5 mm	5.0 mm

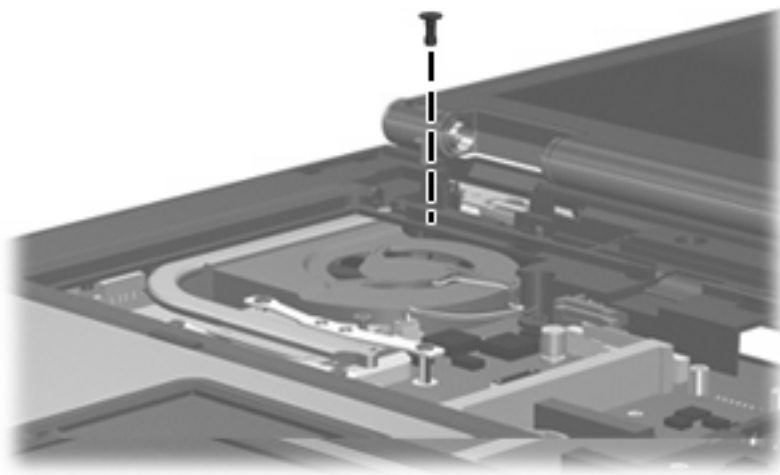

Where used: One screw that secures the fan to the system board

Phillips PM2.0×6.0 screw

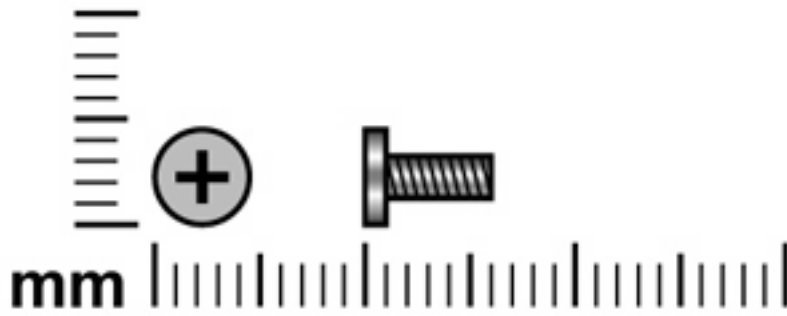

Color	Quantity	Length	Thread	Heat width
Silver	4	6.0 mm	2.0 mm	4.5 mm

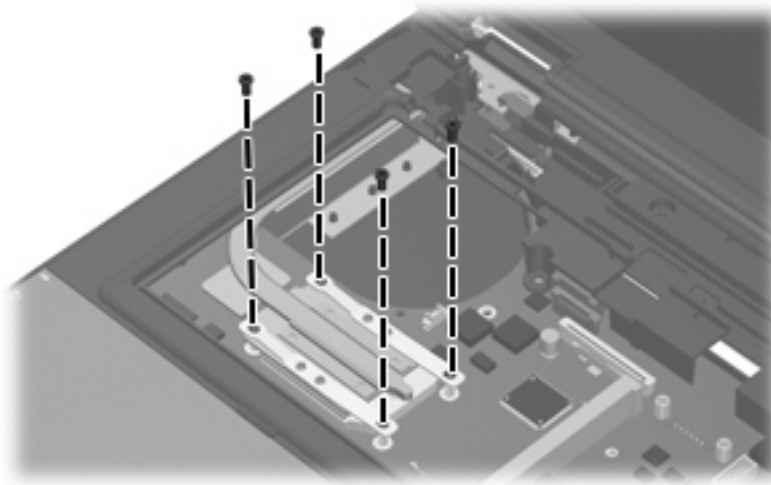

Where used: 4 screws that secure the heat sink to the computer

Torx T8M2.5×6.0 screw

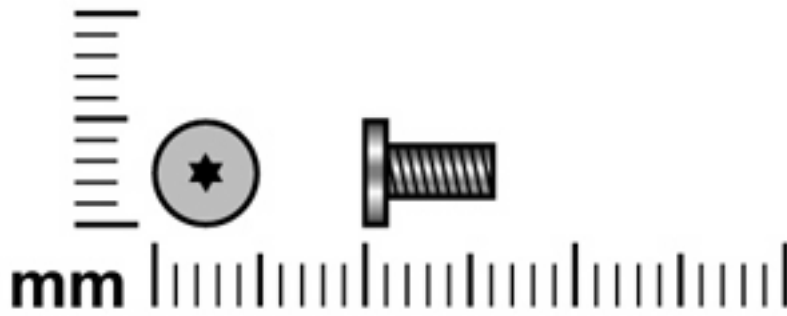

Color	Quantity	Length	Thread	Head diameter
Black	8	6.0 mm	2.5 mm	5.0 mm

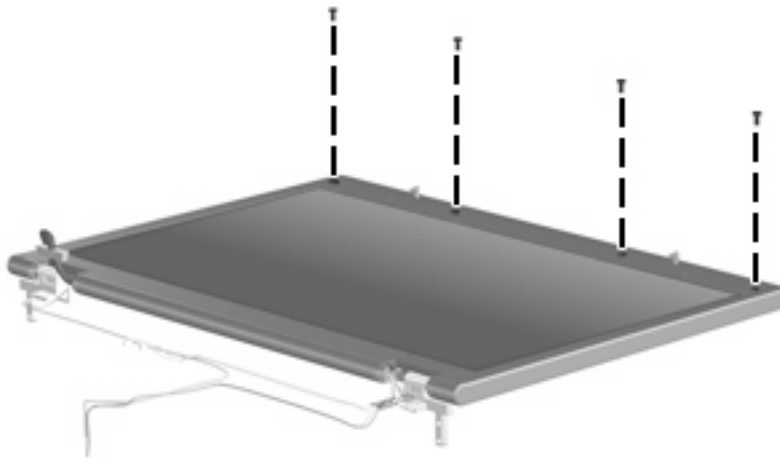

Where used: 4 screws that secure the top edge of the display bezel to the display enclosure



Where used: 4 screws that secure the top edge of the display panel to the display enclosure

Hex HM5.0×9.0 screw lock

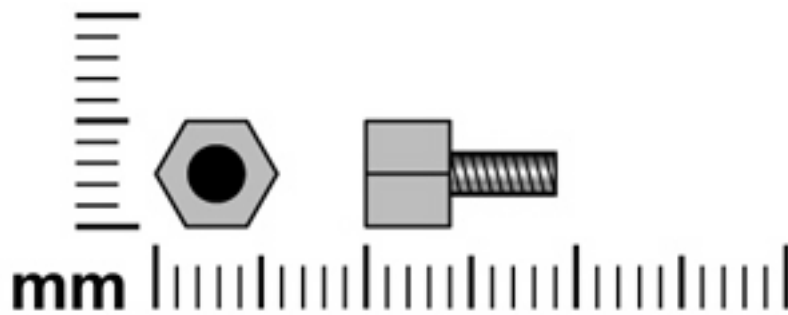

Color	Quantity	Length	Thread	Head diameter
Silver	2	9.0 mm	3.0 mm	5.0 mm

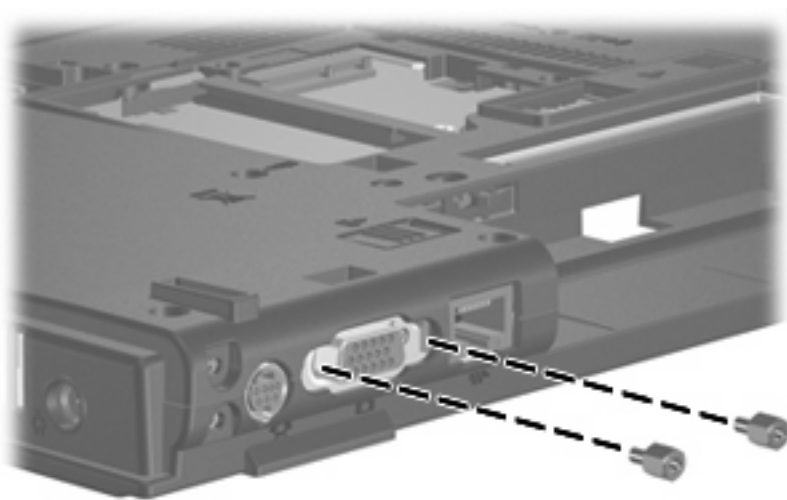

Where used: 2 screw locks that secure the top cover to the computer

Phillips PM2.5×5.0 screw

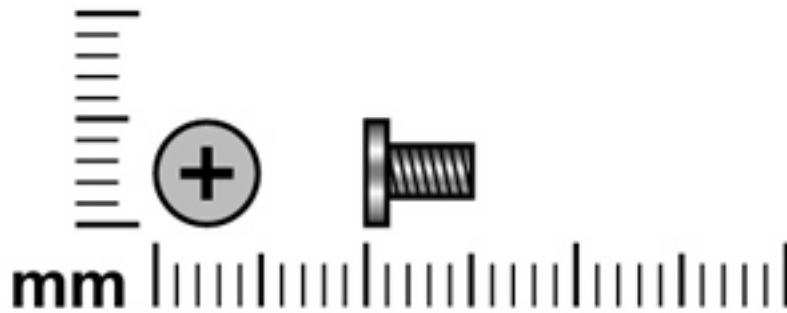

Color	Quantity	Length	Thread	Head diameter
Black	12	5.0 mm	2.5 mm	5.0 mm

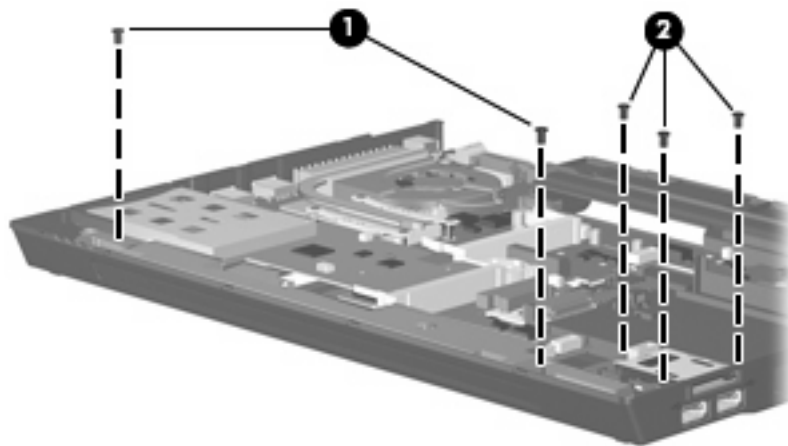

Where used:

- (1) Two screws that secure the speaker assembly to the base enclosure
- (2) Three screws that secure the USB/Media Card Reader board to the base enclosure

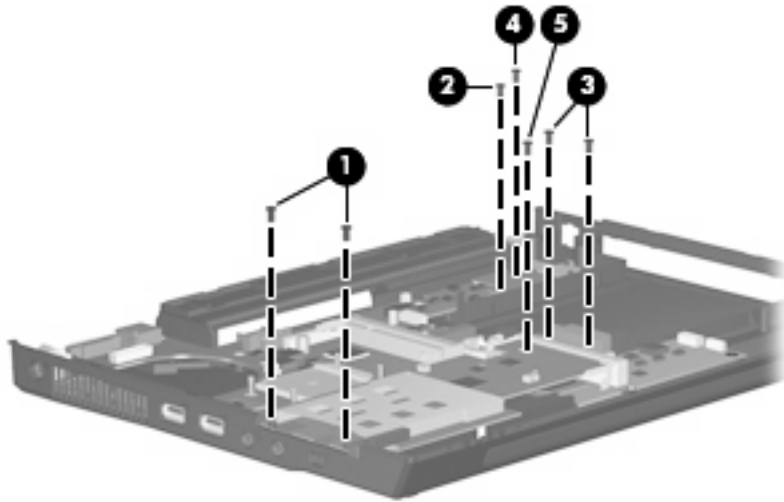

Where used:

- (1) Two screws that secure the system board and PC Card/audio board assembly to the base enclosure
- (2) One screw that secures the system board to the base enclosure
- (3) Two screws that secure the optical drive connector board to the system board
- (4) One screw that secures the SIM slot board to the base enclosure
- (5) One screw that secures the PC Card/audio board assembly to the system board

Phillips PM2.5×3.0 broad-head screw

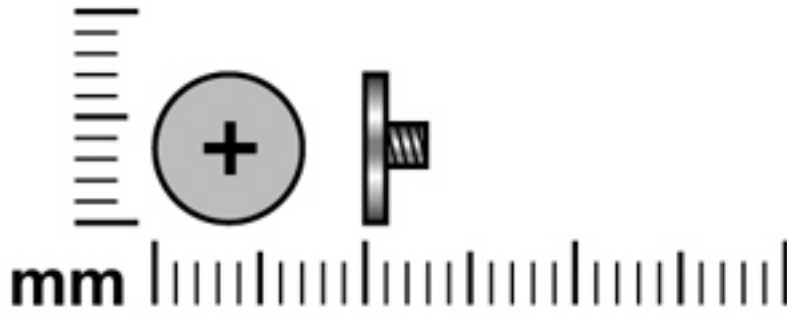

Color	Quantity	Length	Thread	Head diameter
Silver	2	3.0 mm	2.5 mm	7.0 mm

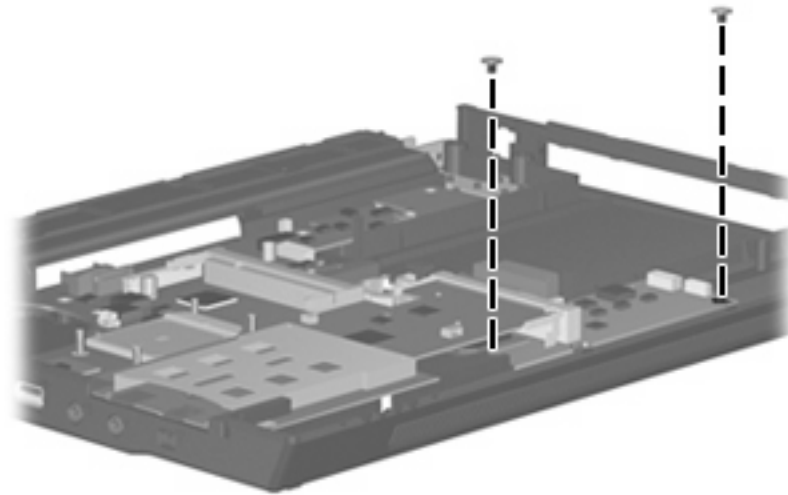

Where used: 2 screws that secure the system board to the base enclosure

8 Backup and recovery in Windows Vista

Creating recovery discs

After setting up the computer for the first time, be sure to create a set of recovery discs of the full factory image. The recovery discs are used to start up (boot) the computer and recover the operating system and software to factory settings in case of system instability or failure.

Note the following guidelines before creating recovery discs:

- You will need high-quality CD-R, DVD-R, or DVD+R media (purchased separately).
-  **NOTE:** Read-write discs, such as CD-RW and DVD±RW discs, are not compatible with HP Backup & Recovery Manager.
- The computer must be connected to AC power during the process.
- Only one set of the recovery discs can be created per computer.
- Number each disc before inserting it into the optical drive of the computer.
- If necessary, you can cancel the disc creation before you have finished creating the recovery discs. The next time you select **Create a set of recovery discs (Recommended)**, you will be prompted to continue the disc creation.

To create a set of recovery discs:

1. Select **Start > All Programs > HP Backup & Recovery > Backup & Recovery Manager**.
2. Click **Next**.
3. Click **Create a set of recovery discs (Recommended)**, and then click **Next**.
4. Follow the on-screen instructions.

Backing up your information

 **NOTE:** You can only recover files that you have previously backed up. HP recommends that you use HP Backup & Recovery Manager to create an entire drive backup as soon as you set up your computer.

With HP Backup & Recovery Manager, you can perform the following tasks:

- Backing up your information regularly to protect your important system files
- Creating system recovery points that allow you to reverse undesirable changes to your computer by restoring the computer to an earlier state
- Scheduling backups at specific intervals or events

When to back up

- On a regularly scheduled basis

 **NOTE:** Set reminders to back up your information periodically.

- Before the computer is repaired or restored
- Before you add or modify hardware or software

Backup suggestions

- Create a set of recovery discs using HP Backup & Recovery Manager.
- Create system recovery points using HP Backup & Recovery Manager, and periodically copy them to disc.
- Store personal files in the Documents folder and back up these folders periodically.
- Back up templates stored in their associated programs.
- Save customized settings in a window, toolbar, or menu bar by taking a screen shot of your settings.

The screen shot can be a time saver if you have to reset your preferences.

To copy the screen and paste it into a word-processing document:

a. Display the screen.

b. Copy the screen.

To copy only the active window, press **alt+fn+prt sc**.

To copy the entire screen, press **fn+prt sc**.

c. Open a word-processing document, and then select **Edit > Paste**.

 **NOTE:** Before you can perform backup and recovery procedures, the computer must be connected to external power.

NOTE: Drivers, utilities, and applications installed by HP can be copied to a CD or to a DVD using HP Backup & Recovery Manager.

Backing up specific files or folders

You can back up specific files or folders to the recovery partition on the hard drive, to an optional external hard drive, or to optical discs (CDs or DVDs).

 **NOTE:** This process will take several minutes, depending on the file size and the speed of the computer.

To back up specific files or folders:

1. Select **Start > All Programs > HP Backup & Recovery > Backup & Recovery Manager**.
2. Click **Next**.
3. Click **Create or manage backups**, and then click **Next**.
4. Click **Back up user created files and folders**, and then click **Next**.
5. Follow the on-screen instructions.

Backing up the entire hard drive

When you perform a complete backup of the hard drive, you are saving the full factory image, including the Windows® operating system, software applications, and all personal files and folders.

 **NOTE:** A copy of the entire hard drive image can be stored on another hard drive, on a network drive, or on recovery discs that you create.

NOTE: This process may take over an hour, depending on your computer speed and the amount of data being stored.

To back up your entire hard drive:

1. Select **Start > All Programs > HP Backup & Recovery > Backup & Recovery Manager**.
2. Click **Next**.
3. Click **Create or manage backups**, and then click **Next**.
4. Click **Create or manage Entire Drive Backups**, and then click **Next**.
5. Follow the on-screen instructions.

Creating recovery points

When you back up modifications since your last backup, you are creating system recovery points. This allows you to save a snapshot of your hard drive at a specific point in time. You can then recover back to that point if you want to reverse subsequent changes made to your system.

 **NOTE:** The first system recovery point, a snapshot of the entire image, is automatically created the first time you perform a backup. Subsequent recovery points make copies of changes made after that time.

HP recommends that you create recovery points at the following times:

- Before you add or extensively modify software or hardware
- Periodically, whenever the system is performing optimally

 **NOTE:** Recovering to an earlier recovery point does not affect data files or e-mails created since that recovery point.

To create a system recovery point:

1. Select **Start > All Programs > HP Backup & Recovery > Backup & Recovery Manager**.
2. Click **Next**.
3. Click **Create or manage backups**, and then click **Next**.
4. Click **Create or manage Recovery Points**, and then click **Next**.
5. Follow the on-screen instructions.

Scheduling backups

Use HP Backup Scheduler to schedule backups for the entire system, for recovery points, or for specific files and folders. With this tool, you can schedule backups at specific intervals (daily, weekly, or monthly) or at specific events, such as at system restart or when you dock to an optional docking station (select models only).

To schedule backups:

1. Select **Start > All Programs > HP Backup & Recovery > HP Backup Scheduler**.
2. Follow the on-screen instructions.

Performing a recovery

 **NOTE:** You can only recover files that you have previously backed up. HP recommends that you use HP Backup & Recovery Manager to create an entire drive backup as soon as you set up your computer.

HP Backup & Recovery Manager helps you with the following tasks for safeguarding your information and restoring it in case of a system failure:

- Recovering important files—This feature helps you reinstall important files without performing a full system recovery.
- Performing a full system recovery—With HP Backup & Recovery Manager, you can recover your full factory image if you experience system failure or instability. HP Backup & Recovery Manager works from a dedicated recovery partition on the hard drive or from recovery discs you create.

Performing a recovery from the recovery discs

To perform a recovery from the recovery discs, follow these steps:

1. Back up all personal files.
2. Insert the first recovery disc into the optical drive and restart the computer.
3. Follow the on-screen instructions.

Performing a recovery from the hard drive

There are 2 ways to initiate a recovery from the hard drive:

- From within Windows
- From the recovery partition

Initiating a recovery in Windows

To initiate a recovery in Windows, follow these steps:

1. Back up all personal files.
2. Select **Start > All Programs > HP Backup & Recovery > Backup & Recovery Manager**.
3. Click **Next**.
4. Click **Perform a recovery**, and then click **Next**.
5. Follow the on-screen instructions.

Initiating a recovery from the hard drive recovery partition

To initiate a recovery from the hard drive recovery partition, follow these steps:

1. Back up all personal files.
2. Restart the computer, and then press **f11** before the Windows operating system loads.
3. Click a recovery option, and then click **Next**.
4. Follow the on-screen instructions.

9 Backup and recovery in Windows XP

Creating recovery discs

After setting up the computer for the first time, be sure to create a set of recovery discs of the full factory image. The recovery discs are used to start up (boot) the computer and recover the operating system and software to factory settings in case of system instability or failure.

Note the following guidelines before creating recovery discs:

- You will need high-quality CD-R, DVD-R, or DVD+R media (purchased separately).
-  **NOTE:** Read-write discs, such as CD-RW and DVD±RW discs, are not compatible with HP Backup & Recovery Manager.
- The computer must be connected to AC power during the process.
- Only one set of the recovery discs can be created per computer.
- Number each disc before inserting it into the optical drive of the computer.
- If necessary, you can cancel the disc creation before you have finished creating the recovery discs. The next time you select **Create factory software recovery CDs or DVDs to recover the system (Highly recommended)**, you will be prompted to continue the disc creation.

To create a set of recovery discs:

1. Select **Start > All Programs > HP Backup and Recovery > HP Backup and Recovery Manager**.
2. Click **Next**.
3. Click **Create factory software recovery CDs or DVDs to recover the system (Highly recommended)**, and then click **Next**.
4. Follow the on-screen instructions.

Backing up your information

 **NOTE:** You can only recover files that you have previously backed up. HP recommends that you use HP Backup and Recovery Manager to create an entire drive backup as soon as you set up your computer.

With HP Backup and Recovery Manager, you can perform the following tasks:

- Backing up your information regularly to protect your important system files
- Creating system recovery points that allow you to reverse undesirable changes to your computer by restoring the computer to an earlier state
- Scheduling backups at specific intervals or events

When to back up

- On a regularly scheduled basis

 **NOTE:** Set reminders to back up your information periodically.

- Before the computer is repaired or restored
- Before you add or modify hardware or software

Backup suggestions

- Create a set of recovery discs using HP Backup and Recovery Manager.
- Create system recovery points using HP Backup and Recovery Manager, and periodically copy them to disc.
- Store personal files in the My Documents folder and back up these folders periodically.
- Back up templates stored in their associated programs.
- Save customized settings in a window, toolbar, or menu bar by taking a screen shot of your settings.

The screen shot can be a time saver if you have to reset your preferences.

To copy the screen and paste it into a word-processing document:

- a. Display the screen.
- b. Copy the screen.
To copy only the active window, press **alt+fn+prt sc**.
To copy the entire screen, press **fn+prt sc**.
- c. Open a word-processing document, and then select **Edit > Paste**.

 **NOTE:** Before you can perform Backup and Recovery procedures, the computer must be connected to external power.

NOTE: Drivers, utilities, and applications installed by HP can be copied to a CD or to a DVD using HP Backup and Recovery Manager.

Backing up specific files or folders

You can back up specific files or folders to the recovery partition on the hard drive, to an optional external hard drive, or to optical discs (CDs or DVDs).

 **NOTE:** This process will take several minutes, depending on the file size and the speed of the computer.

To back up specific files or folders:

1. Select **Start > All Programs > HP Backup and Recovery > HP Backup and Recovery Manager**.
2. Click **Next**.
3. Click **Back up to protect system settings and important data files**, and then click **Next**.
4. Click **Back up individual files and folders**, and then click **Next**.
5. Follow the on-screen instructions.

Backing up the entire hard drive

When you perform a complete backup of the hard drive, you are saving the full factory image, including the Windows® operating system, software applications, and all personal files and folders.

 **NOTE:** A copy of the entire hard drive image can be stored on another hard drive, on a network drive, or on recovery discs that you create.

NOTE: This process may take over an hour, depending on your computer speed and the amount of data being stored.

To back up your entire hard drive:

1. Select **Start > All Programs > HP Backup and Recovery > HP Backup and Recovery Manager**.
2. Click **Next**.
3. Click **Back up to protect system settings and important data files**, and then click **Next**.
4. Click **Back up entire hard drive**, and then click **Next**.
5. Follow the on-screen instructions.

Creating recovery points

When you back up modifications since your last backup, you are creating system recovery points. This allows you to save a snapshot of your hard drive at a specific point in time. You can then recover back to that point if you want to reverse subsequent changes made to your system.

 **NOTE:** The first system recovery point, a snapshot of the entire image, is automatically created the first time you perform a backup. Subsequent recovery points make copies of changes made after that time.

HP recommends that you create recovery points at the following times:

- Before you add or extensively modify software or hardware
- Periodically, whenever the system is performing optimally

 **NOTE:** Recovering to an earlier recovery point does not affect data files or e-mails created since that recovery point.

To create a system recovery point:

1. Select **Start > All Programs > HP Backup and Recovery > HP Backup and Recovery Manager**.
2. Click **Next**.
3. Click **Back up to protect system settings and important data files**, and then click **Next**.
4. Click **Create or manage Recovery Points**, and then click **Next**.
5. Follow the on-screen instructions.

Scheduling backups

Use HP Backup Scheduler to schedule backups for the entire system, for recovery points, or for specific files and folders. With this tool, you can schedule backups at specific intervals (daily, weekly, or monthly) or at specific events, such as at system restart or when you dock to an optional docking station (select models only).

To schedule backups:

1. Select **Start > All Programs > HP Backup and Recovery > HP Backup Scheduler**.
2. Follow the on-screen instructions.

Performing a recovery

 **NOTE:** You can only recover files that you have previously backed up. HP recommends that you use HP Backup and Recovery Manager to create an entire drive backup as soon as you set up your computer.

HP Backup and Recovery Manager helps you with the following tasks for safeguarding your information and restoring it in case of a system failure:

- Recovering important files—This feature helps you reinstall important files without performing a full system recovery.
- Performing a full system recovery—With HP Backup and Recovery Manager, you can recover your full factory image if you experience system failure or instability. HP Backup and Recovery Manager works from a dedicated recovery partition on the hard drive or from recovery discs you create.

Performing a recovery from the recovery discs

To perform a recovery from the recovery discs, follow these steps:

1. Back up all personal files.
2. Insert the first recovery disc into the optical drive and restart the computer.
3. Follow the on-screen instructions.

Performing a recovery from the hard drive

There are 2 ways to initiate a recovery from the hard drive:

- From within Windows
- From the recovery partition

Initiating a recovery in Windows

To initiate a recovery in Windows, follow these steps:

1. Back up all personal files.
2. Select **Start > All Programs > HP Backup and Recovery > HP Backup and Recovery Manager**.
3. Click **Next**.
4. Click **Recover important files or the entire system**, and then click **Next**.
5. Follow the on-screen instructions.

Initiating a recovery from the hard drive recovery partition

To initiate a recovery from the hard drive recovery partition, follow these steps:

1. Back up all personal files.
2. Restart the computer, and then press **f11** before the Windows operating system loads.
3. Click a recovery option, and then click **Next**.
4. Follow the on-screen instructions.

10 Connector pin assignments

Audio-out (headphone)

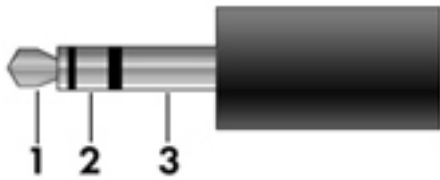

Pin	Signal
1	Audio out, left channel
2	Audio out, right channel
3	Ground

Audio-in (microphone)

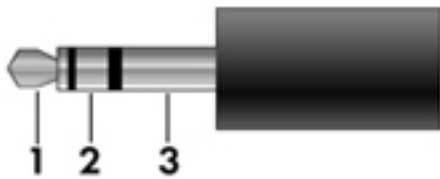

Pin	Signal
1	Audio signal in
2	Audio signal in
3	Ground

External monitor

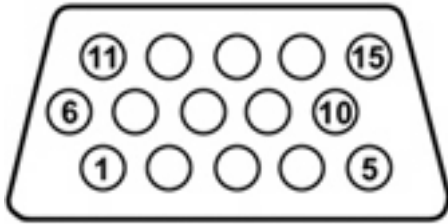

Pin	Signal
1	Red analog
2	Green analog
3	Blue analog
4	Not connected
5	Ground
6	Ground analog
7	Ground analog
8	Ground analog
9	+5 VDC
10	Ground
11	Monitor detect
12	DDC 2B data
13	Horizontal sync
14	Vertical sync
15	DDC 2B clock

RJ-11 (modem)

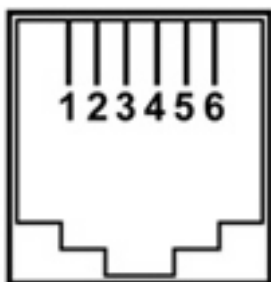

Pin	Signal
1	Unused
2	Tip
3	Ring
4	Unused
5	Unused
6	Unused

RJ-45 (network)

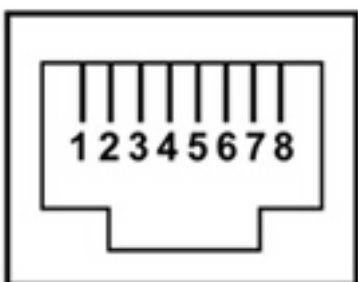

Pin	Signal
1	Transmit +
2	Transmit -
3	Receive +
4	Unused
5	Unused
6	Receive -
7	Unused
8	Unused

S-Video-out



Pin	Signal
1	S-VHS color (C) signal
2	Composite video signal
3	S-VHS intensity (Y) signal
4	S-VHS color ground
5	TV-CD
6	S-VHS intensity ground
7	Composite video ground

Universal Serial Bus

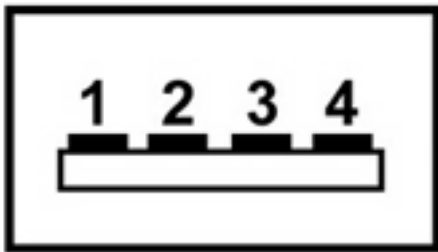

Pin	Signal
1	+5 VDC
2	Data -
3	Data +
4	Ground

11 Power cord set requirements

The wide range input feature of the computer permits it to operate from any line voltage from 100 to 120 volts AC or from 220 to 240 volts AC.

The 3-conductor power cord set included with the computer meets the requirements for use in the country or region where the equipment is purchased.

Power cord sets for use in other countries or regions must meet the requirements of the country or region where the computer is used.

Requirements for all countries and regions

The requirements listed below are applicable to all countries and regions:

- The length of the power cord set must be at least 1.5 m (5.0 ft) and no more than 2.0 m (6.5 ft).
- All power cord sets must be approved by an acceptable accredited agency responsible for evaluation in the country and region where the power cord set will be used.
- The power cord sets must have a minimum current capacity of 10 amps and a nominal voltage rating of 125 or 250 V AC, as required by each country and region's power system.
- The appliance coupler must meet the mechanical configuration of an EN 60 320/IEC 320 Standard Sheet C13 connector for mating with the appliance inlet on the back of the computer.

Requirements for specific countries and regions

Country or region	Accredited agency	Applicable note number
Australia	EANSW	1
Austria	OVE	1
Belgium	CEBC	1
Canada	CSA	2
Denmark	DEMKO	1
Finland	FIMKO	1
France	UTE	1
Germany	VDE	1
Italy	IMQ	1
Japan	METI	3
Korea	EK	4
The Netherlands	KEMA	1
Norway	NEMKO	1
The People's Republic of China	CCC	5
Sweden	SEMKO	1
Switzerland	SEV	1
Taiwan	BSMI	4
The United Kingdom	BSI	1
The United States	UL	2

1. The flexible cord must be Type HO5VV-F, 3-conductor, 1.0-mm² conductor size. Power cord set fittings (appliance coupler and wall plug) must bear the certification mark of the agency responsible for evaluation in the country and region where it will be used.
2. The flexible cord must be Type SPT-3 or equivalent, No. 18 AWG, 3-conductor. The wall plug must be a two-pole grounding type with a NEMA 5-15P (15 A, 125 V) or NEMA 6-15P (15 A, 250 V) configuration.
3. The appliance coupler, flexible cord, and wall plug must bear a "T" mark and registration number in accordance with the Japanese Dentori Law. The flexible cord must be Type VCT or VCTF, 3-conductor, 1.00-mm² conductor size. The wall plug must be a two-pole grounding type with a Japanese Industrial Standard C8303 (7 A, 125 V) configuration.
4. The flexible cord must be Type RVV, 3-conductor, 0.75-mm² conductor size. Power cord set fittings (appliance coupler and wall plug) must bear the certification mark of the agency responsible for evaluation in the country and region where it will be used.
5. The flexible cord must be Type VCTF, 3-conductor, 0.75-mm² conductor size. Power cord set fittings (appliance coupler and wall plug) must bear the certification mark of the agency responsible for evaluation in the country and region where it will be used.

12 Recycling

Battery

When a battery has reached the end of its useful life, do not dispose of the battery in general household waste. Follow the local laws and regulations in your area for computer battery disposal.

Display

-
- ⚠ **WARNING!** The backlight contains mercury. Exercise caution when removing and handling the backlight to avoid damaging this component and causing exposure to the mercury.
 - ⚠ **CAUTION:** The procedures in this appendix can result in damage to display components. The only components intended for recycling purposes are the liquid crystal display (LCD) panel and the backlight. Careful handling must be exercised when removing these components. When you remove these components, handle them carefully.
 - 📄 **NOTE: Materials Disposal.** This HP product contains mercury in the backlight in the display assembly that might require special handling at end-of-life. Disposal of mercury may be regulated because of environmental considerations. For disposal or recycling information, contact your local authorities, or see the Electronic Industries Alliance (EIA) Web site at <http://www.eiae.org>.
-

This section provides disassembly instructions for the display assembly. The display assembly must be disassembled to gain access to the backlight **(1)** and the liquid crystal display (LCD) panel **(2)**.



-
- 📄 **NOTE:** The procedures provided in this appendix are general disassembly instructions. Specific details, such as screw sizes, quantities, and locations, and component shapes and sizes, can vary from one computer model to another.
-

Perform the following steps to disassemble the display assembly:

1. Remove all screw covers **(1)** and screws **(2)** that secure the display bezel to the display assembly.

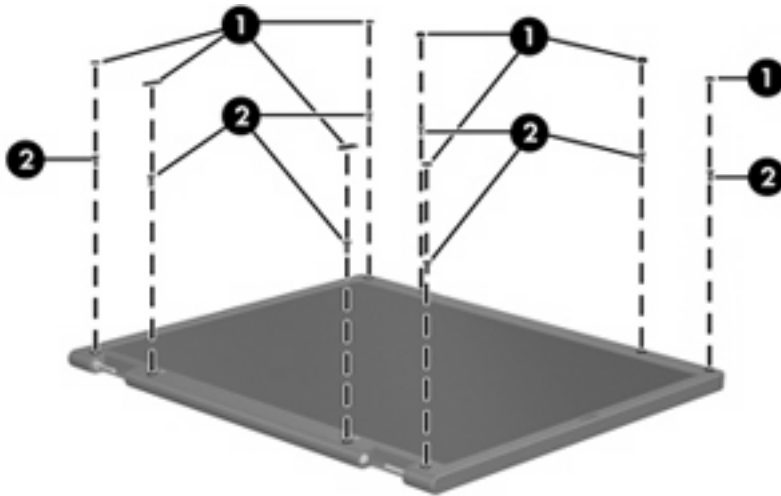

2. Lift up and out on the left and right inside edges **(1)** and the top and bottom inside edges **(2)** of the display bezel until the bezel disengages from the display assembly.
3. Remove the display bezel **(3)**.

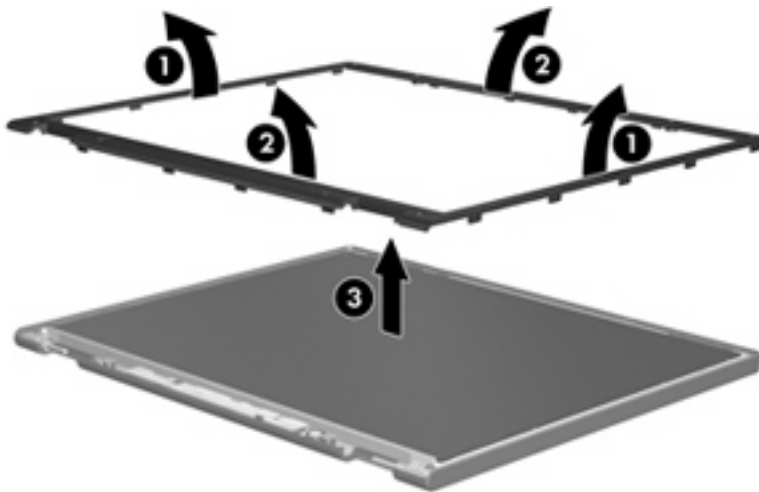

4. Disconnect all display panel cables **(1)** from the display inverter and remove the inverter **(2)**.

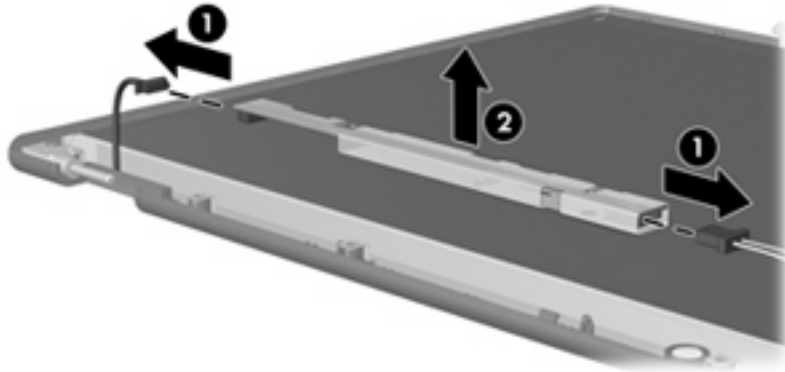

5. Remove all screws **(1)** that secure the display panel assembly to the display enclosure.
6. Remove the display panel assembly **(2)** from the display enclosure.

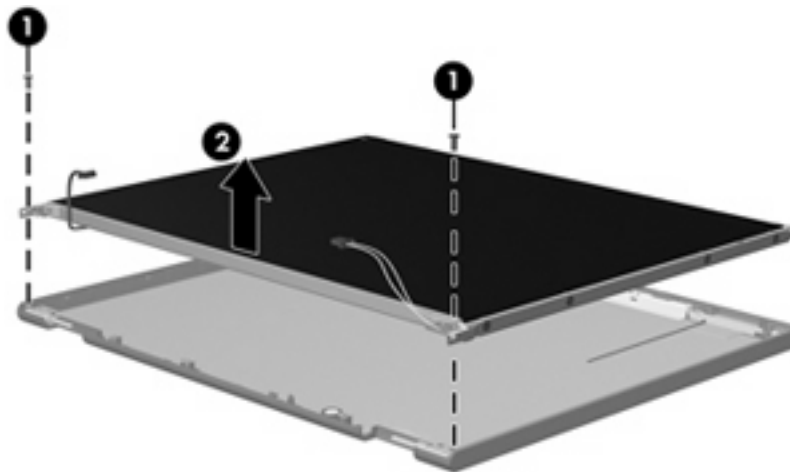

7. Turn the display panel assembly upside down.
8. Remove all screws that secure the display panel frame to the display panel.

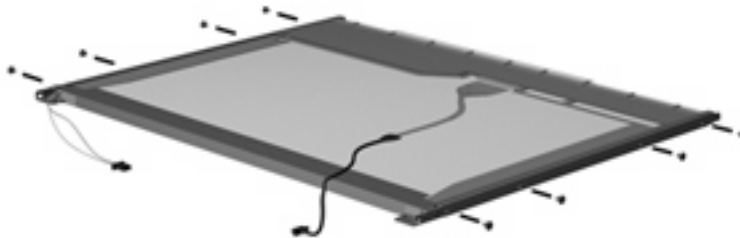

9. Use a sharp-edged tool to cut the tape **(1)** that secures the sides of the display panel to the display panel frame.

10. Remove the display panel frame **(2)** from the display panel.

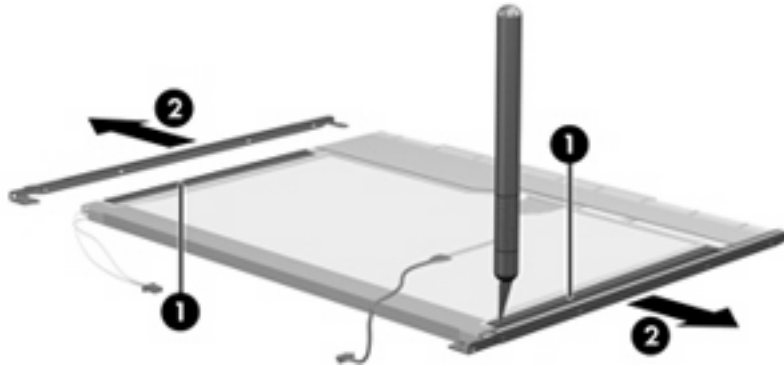

11. Remove the screws **(1)** that secure the backlight cover to the display panel.
12. Lift the top edge of the backlight cover **(2)** and swing it outward.

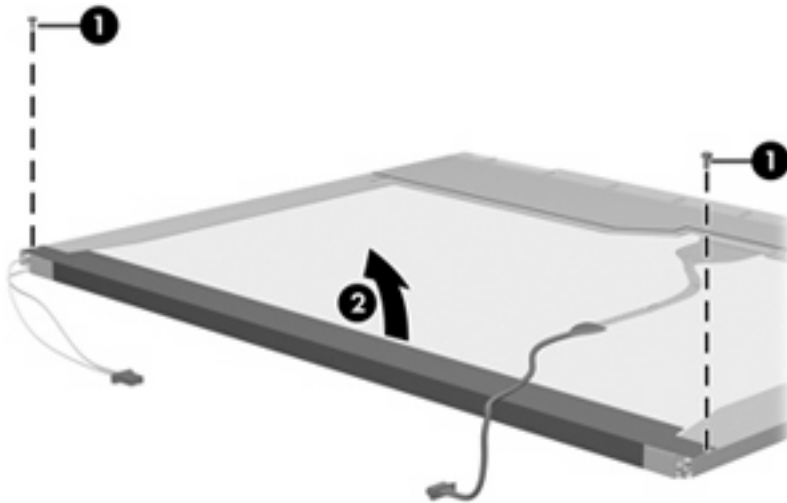

13. Remove the backlight cover.
14. Turn the display panel right-side up.

15. Remove the backlight cables (1) from the clip (2) in the display panel.

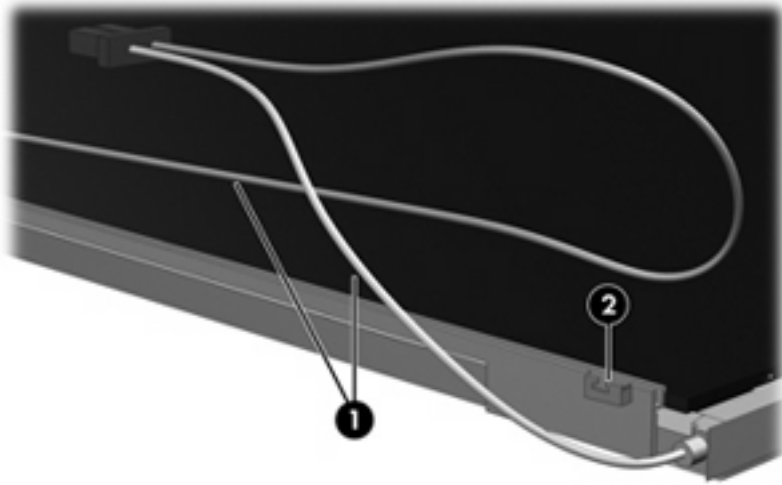

16. Turn the display panel upside down.

⚠ WARNING! The backlight contains mercury. Exercise caution when removing and handling the backlight to avoid damaging this component and causing exposure to the mercury.

17. Remove the backlight frame from the display panel.

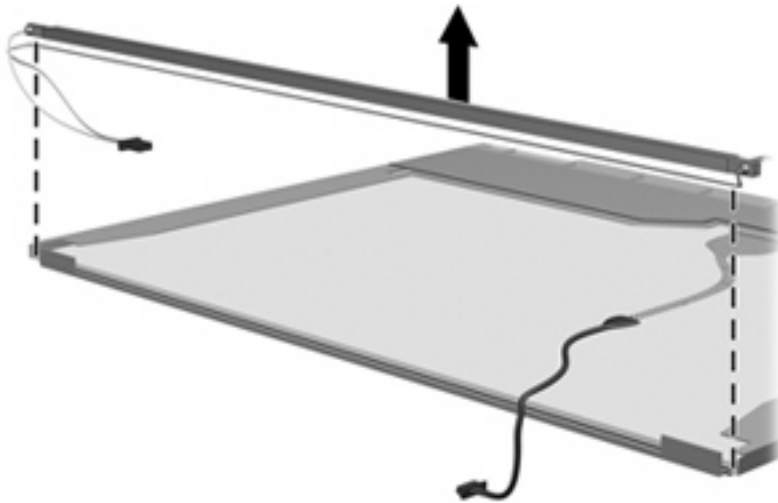

18. Remove the backlight from the backlight frame.

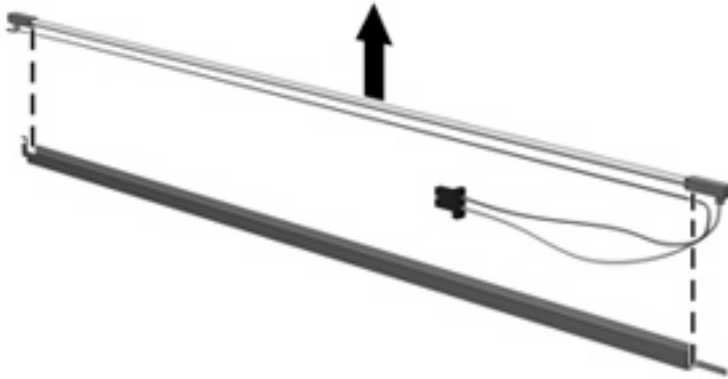

19. Disconnect the display cable (1) from the LCD panel.
20. Remove the screws (2) that secure the LCD panel to the display rear panel.
21. Release the LCD panel (3) from the display rear panel.
22. Release the tape (4) that secures the LCD panel to the display rear panel.

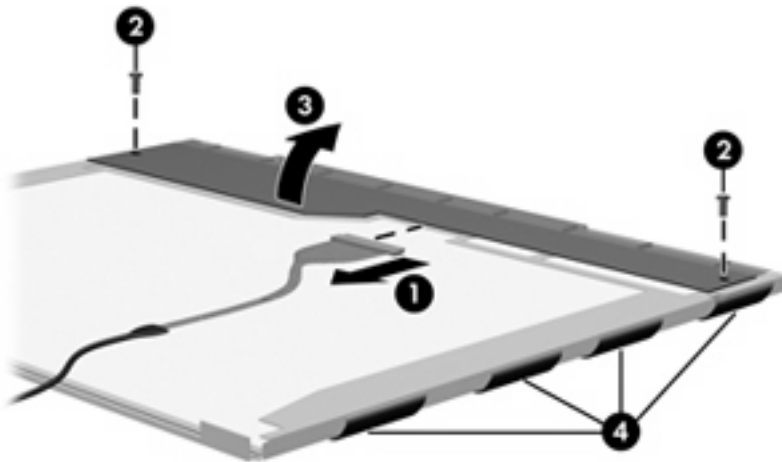

23. Remove the LCD panel.

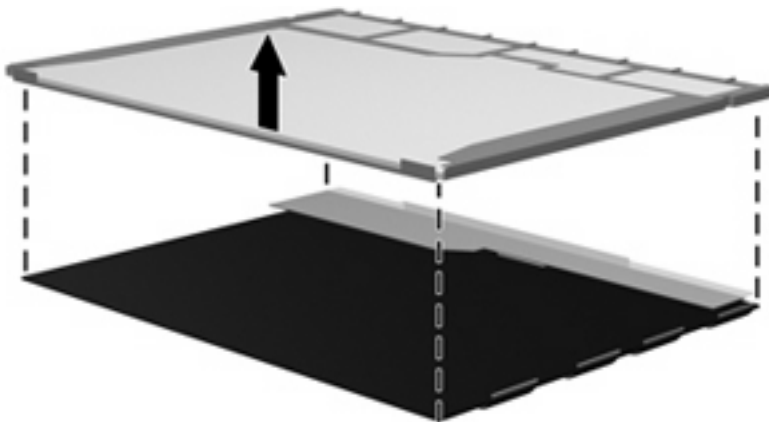

24. Recycle the LCD panel and backlight.

Index

Symbols/Numerics

1394 port 17

A

AC adapter, spare part
numbers 33, 34

accessory battery connector 20

antennae, disconnecting 60, 69

applications key, Windows 13

audio, product description 3, 8

audio-in jack

location 17

pin assignments 147

audio-out jack

location 17

pin assignments 147

B

backing up 136, 142

backup

files and folders 137, 143

hard drive 137, 143

modifications made to the

system 138, 144

scheduling 138, 144

base enclosure, spare part

numbers 27, 37

battery

location 20

removal 48

spare part numbers 27, 38,
48

specifications 107

battery bay 20

battery light 14, 16

battery release latch 20

Bluetooth module

removal 54

spare part numbers 29, 34,
40, 54

Bluetooth module cable

illustrated 31

removal 84

Bluetooth module compartment 20

Bluetooth module cover

illustrated 30

removal 55

boot options 101

boot order 101

bottom components 20

buttons

info 12

PC Card eject 17

power 11

presentation 12

volume mute 12

wireless 12

C

Cable Kit

contents 31

spare part number 25, 31,
38

cables, service considerations 42

caps lock light 14

chipset, product description 1, 6

CMOS clearing 46

components

bottom 20

buttons 11

fingerprint reader 11

front 16

keys 13

left-side 17

lights 14

pointing device 15

rear 18

right-side 19

switches 11

top 11

TouchPad 15

computer feet

illustrated 30

locations 54

Computer Setup

accessing 97

Diagnostics menu 100

File menu 99

navigating and selecting 98

restoring factory settings 98

Security menu 100

System Configuration

menu 101

using 98

computer specifications 103

connectors

accessory battery 20

docking 20

service considerations 42

creating recovery points 138,
144

D

Diagnostics menu 100

Disk Sanitizer 100

diskette drive

precautions 42

product description 3, 7

display assembly

removal 76

spare part numbers 23, 38,
76

display bezel

release 50

removal 79

spare part number 23, 39

display component recycling 153

display enclosure, spare part

numbers 23, 39, 40

- display hinge
 - removal 79
 - spare part number 23, 39, 80
- display inverter
 - removal 50
 - spare part number 23, 39, 50
- display panel
 - removal 79
 - spare part numbers 39
- display release latch 16
- display specifications 104, 105
- display switch 12
- docking connector 20
- docking support, product
 - description 4, 9
- drive light 15, 16
- DriveLock password 100
- drives, boot order 101
- drives, preventing damage 42
- DVD-ROM drive
 - location 19
 - precautions 42
 - removal 62
 - spare part number 30, 32, 38, 62
 - specifications 110
- DVD/CD-RW Combo Drive
 - location 19
 - precautions 42
 - removal 62
 - spare part number 30, 32, 38, 62
 - specifications 109
- DVD±RW and CD-RW Super Multi Double-Layer Combo Drive
 - location 19
 - precautions 42
 - removal 62
 - spare part numbers 30, 32, 39, 62
 - specifications 108

E

- electrostatic discharge 43
- Ethernet, product description 3, 8
- Execution Disable 101
- external media cards, product
 - description 4, 9

- external monitor port
 - location 18
 - pin assignments 148

F

- fan
 - removal 71
 - spare part number 24, 39, 71

feet

- illustrated 30
- locations 54

- File menu 99

- fingerprint reader 12

- front components 16

- function keys 13

G

- graphics, product description 1, 6

- grounding equipment and
 - methods 45

H

hard drive

- location 20
- precautions 42
- product description 2, 7
- removal 52
- spare part numbers 27, 32, 39, 52
- specifications 106

- hard drive backup 137, 143

- hard drive bay 20

- hard drive bracket, removal 53

hard drive cover

- illustrated 30
- removal 52

- hard drive recovery 139, 145

- hard drive test 100

headphone jack

- location 17
- pin assignments 147

heat sink

- removal 72
- spare part numbers 25, 39, 40, 72

hinge

- removal 79
- spare part number 23, 39, 80

I

- I/O address specifications 113

- info button 12

- interrupt specifications 112

inverter

- removal 50
- spare part number 23, 39, 50

J

jacks

- audio-in 17
- audio-out 17
- headphone 17
- microphone 17
- modem 19
- network 18
- RJ-11 19
- RJ-45 18
- S-Video-out 18

K

keyboard

- product description 4, 9
- removal 64
- spare part numbers 24, 37, 64

- keypad keys 13

keys

- esc 13
- fn 13
- function 13
- Windows applications 13
- Windows logo 13

L

- LAN Power Save 101

- language, changing in Computer Setup 101

- left-side components 17

- legacy support, USB 97, 101

lights

- battery 14, 16
- caps lock 14
- drive 15, 16
- num lock 14
- power 14, 16
- volume down 14
- volume mute 14
- volume up 14
- wireless 14, 16

M

- mass storage devices, spare part numbers 32
- Media Card Reader 19
- memory check 100
- memory map specifications 115
- memory module
 - product description 2, 7
 - removal 56, 66
 - spare part numbers 25, 34, 56, 66
- memory/WLAN module compartment 20
- memory/WLAN module compartment cover
 - illustrated 30
 - removal 56
- microphone
 - illustrated 31
 - removal 83
- microphone jack
 - location 17
 - pin assignments 147
- modem jack
 - location 19
 - pin assignments 149
- modem module
 - product description 3, 8
 - removal 92
 - spare part numbers 26, 35, 40, 92
- modem module cable
 - illustrated 31
 - removal 84
- monitor port
 - location 18
 - pin assignments 148

N

- navigating in Computer Setup 98
- network jack
 - location 18
 - pin assignments 149
- num lock light 14

O

- operating system, product description 5, 10
- optical drive
 - location 19

- precautions 42
- product description 2, 7
- removal 62
- spare part numbers 30, 32, 38, 39, 62
- specifications 108, 109, 110
- optical drive bracket, removal 63
- optical drive connector board
 - removal 90
 - spare part number 27, 38, 90

P

- packing guidelines 44
- panels, product description 1, 6
- parallel port mode 101
- password clearing 46
- passwords 100
- PC Card eject button 17
- PC Card slot 17
- PC Card slot bezel
 - illustrated 30
 - removal 89
- PC Card/audio board assembly
 - removal 91
 - spare part numbers 26, 38, 91
- pin assignments
 - audio-in jack 147
 - audio-out jack 147
 - external monitor port 148
 - headphone jack 147
 - microphone jack 147
 - modem jack 149
 - monitor port 148
 - network jack 149
 - RJ-11 149
 - RJ-45 jack 149
 - S-Video-out jack 150
 - Universal Serial Bus (USB) port 150
- plastic parts 41
- Plastics Kit
 - contents 30
 - spare part number 25, 30, 39
- pointing device
 - components 15
 - product description 9

- pointing devices, product description 4
- ports
 - 1394 17
 - external monitor 18
 - monitor 18
 - product description 4, 9
 - Universal Serial Bus (USB) 17, 19
- power button 11
- power connector 17
- power cord
 - set requirements 151
 - spare part numbers 33, 34
- power light 14, 16
- power requirements, product description 5, 9
- power-on password 100
- presentation button 12
- processor
 - product description 1, 6
 - removal 74
 - spare part numbers 25, 34, 38, 39, 40, 74
- product description
 - audio 3, 8
 - chipset 1, 6
 - diskette drive 3, 7
 - docking support 4, 9
 - Ethernet 3, 8
 - external media cards 4, 9
 - graphics 1, 6
 - hard drives 2, 7
 - keyboard 4, 9
 - memory module 2, 7
 - modem module 3, 8
 - operating system 5, 10
 - optical drives 2, 7
 - panels 1, 6
 - pointing devices 4, 9
 - ports 4, 9
 - power requirements 5, 9
 - processors 1, 6
 - security 5, 10
 - serviceability 5, 10
 - wireless 3, 8

R

- rear components 18

- recovery discs
 - creating 135, 141
 - using 139, 145
- recovery partition 140, 146
- recovery points 138, 144
- removal/replacement
 - preliminaries 41
 - procedures 47
- restoring Computer Setup factory settings 98
- right-side components 19
- RJ-11 jack
 - location 19
 - pin assignments 149
- RJ-45 jack
 - location 18
 - pin assignments 149
- RTC battery
 - removal 67
 - spare part number 26, 40, 67

S

- S-Video-out jack
 - location 18
 - pin assignments 150
- scheduling backups 138, 144
- Screw Kit
 - contents 117
 - spare part number 33, 39
- screw listing 117
- security cable slot 18
- Security menu 100
- security, product description 5, 10
- selecting in the Computer Setup 98
- serial number 21, 47
- service considerations 41
- serviceability, product description 5, 10
- SIM slot board
 - removal 94
 - spare part number 26, 39, 94
- SIM, removal 49
- Smart card reader module, spare part number 33, 39
- smart card security 100

- speaker assembly
 - removal 85
 - spare part number 26, 38, 85
- speakers 16
- specifications
 - battery 107
 - computer 103
 - display 104, 105
 - DVD-ROM drive 110
 - DVD/CD-RW Combo Drive 109
 - DVD±RW and CD-RW Super Multi Double-Layer Combo Drive 108
 - hard drive 106
 - I/O addresses 113
 - interrupts 112
 - memory map 115
 - optical drive 108, 109, 110
 - system DMA 111
- startup check 100
- static-shielding materials 45
- stringent security 100
- switch cover
 - removal 70
 - spare part numbers 23, 39, 70
- system backup 137, 143
- system board
 - removal 88
 - spare part numbers 26, 38, 40, 88
- System Configuration menu 101
- system DMA 111
- system fan 101
- system information 99
- system memory map 115
- system recovery points 138, 144

T

- Thermal Material Kit, spare part numbers 25, 34, 39, 72
- thermal material, replacement 73
- tools required 41
- top components 11
- top cover
 - removal 81
 - spare part numbers 26, 38, 81

- TouchPad 15
- TouchPad button 15
- TouchPad components 15
- TouchPad scroll zone 15
- transporting guidelines 44

U

- Universal Serial Bus (USB) port
 - location 17, 19
 - pin assignments 150
- unknown password 46
- USB legacy support 97, 101
- USB/Media Card Reader board
 - removal 86
 - spare part number 27, 38, 86

V

- vents 17, 20
- volume down light 14
- volume mute button 12
- volume mute light 14
- volume scroll zone 12
- volume up light 14

W

- Windows applications key 13
- Windows logo key 13
- wireless antennae,
 - disconnecting 60, 69
- wireless button 12
- wireless light 14, 16
- wireless, product description 3, 8
- WLAN module
 - removal 58
 - spare part numbers 27, 34, 35, 58
- workstation guidelines 44
- WWAN module
 - removal 68
 - spare part numbers 24, 34, 40, 68

