

ARCHITECT & ENGINEER SPECIFICATIONS

**SECTION 28 23 29
VIDEO SURVEILLANCE REMOTE DEVICES AND SENSORS**

SNC-EB630

**Fixed-type Full High Definition (FHD) CS-mount Network Camera
Powered by IPELA ENGINE EX
(Software version 1.6.0 or later)**

PART 2 – PRODUCTS

2.01 NETWORK CAMERA SPECIFICATIONS

Table of Contents

A. MAIN FEATURES.....	2
B. CAMERA	6
C. CAMERA FEATURES	8
D. VIDEO	10
E. INTELLIGENT VIDEO ANALYTICS.....	14
F. AUDIO	16
G. SYSTEM REQUIREMENTS & NETWORK	17
H. INTERFACES	20
I. GENERAL SPECIFICATIONS.....	21
J. REGULATORY SPECIFICATIONS	22
K. SUPPLIED ACCESSORIES	23
L. OPTIONAL ACCESSORIES.....	24
M. DIMENSIONS	25

A. MAIN FEATURES:

1. Fixed-type Full High Definition (FHD) CS-mount Network Camera
2. 1080p FHD picture quality (1920 x 1080 pixels maximum resolution), supporting H.264 at 30 fps (IP)
3. Wide Dynamic range (Wide-D) equivalent to 90 dB
4. Simultaneously encoding up to 3 of the following streams in any combination, including multiple instances of the same compression format: JPEG and/or H.264 (High/Main/ Baseline Profile)
5. Minimum scene illumination of 0.1 lx in Color mode and 0.07 lx in Black and White (B/W) mode (50 IRE [IP], F 1.2, View-DR Off, VE Off, Auto Gain Control maximum rate MAX, 1/30s, 30fps).
6. Picture mode:
Picture mode shall be selectable from a range of camera scenes in the setting menu to optimize picture quality in various applications. This mode has the following options;
 - “Standard”
 - “Situation Priority - Moving object” to stabilize images
 - “Situation Priority - Low noise” to reducing noise on images, especially dark scenes
 - “Flickerless” to reduce the flicker on images according to power frequency (50 Hz or 60 Hz) of the lighting
7. IPELA ENGINE EX:
Integrated signal processing system for high picture quality shall combine unique signal processing and video analytics technologies. This signal processing system provides four unique features such as View-DR, XDNR, and DEP Advanced.
8. Visibility enhanced wide Dynamic Range (View-DR) :
This technology shall be a combination of unique full-capture Wide Dynamic range (Wide-D) technology, the high-speed Exmor CMOS sensor, and Visibility Enhancer (VE) technology.

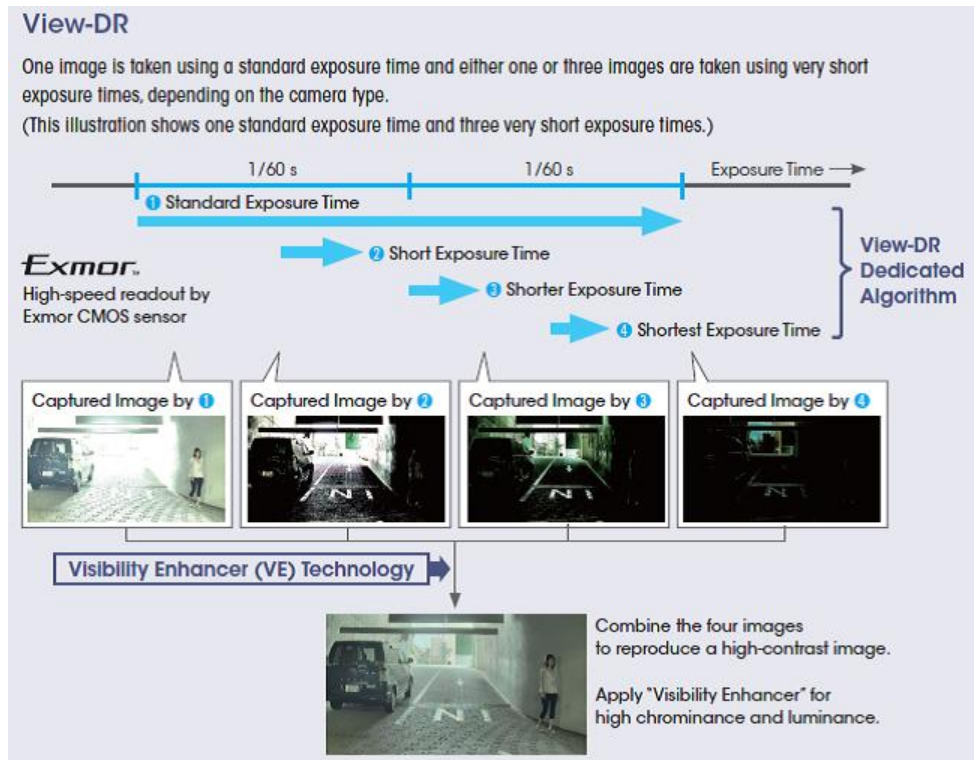

The full-capture wide dynamic range technology shall use an electronic shutter to capture multiple images and reproduce each frame.

One image is taken using a standard exposure time and either 1 or 3 additional images are taken using very short exposure times, depending on the camera type*.

(*This model shall synthesize a single image from 2 images taken by slow shutter speed.)

With the advanced View-DR algorithm, all of the electrons converted from the captured light are fully used by the imager, which is significantly different from some other Wide-D technologies in the industry which discard approximately half of these electrons.

As a result, View-DR nearly doubles the sensitivity that is offered by conventional Wide-D technologies.

The level of the wide dynamic range (View-DR) setting changes automatically depending on lighting condition.

When the light level drops, the wide dynamic range (View-DR) turns off automatically.

9. Exmor CMOS:

This sensor shall realize high quality and low noise images.

Due to its high-speed readout characteristics, this sensor is used to capture multiple HD resolution images at a very high speed.

10. Visibility Enhancer (VE):

This technology optimizes the brightness and color reproduction of an image dynamically on a pixel-by-pixel basis while continuously adapting to the scene. This method differs from the technique of using the preset gamma curves.

Technically, this technology stretches the contrast in both the backlit portions and the shadows within the given dynamic range, which is different from unique wide dynamic range technologies. This technology also contributes to the high sensitivity of the camera.

By combining this technology with a unique noise reduction feature named eXcellent Dynamic Noise Reduction (XDNR), the camera can reproduce clear and bright images in very low-light conditions, while keeping noise at a minimal level.
11. eXcellent Dynamic Noise Reduction (XDNR):

This technology reduces Auto Gain Control (AGC) noise to provide clear images without motion blur. This also reduces image data size.
12. XDNR and VE can be used in conjunction with each other and shall provide approximately 4 times the sensitivity compared to the condition where both features are set to off.
13. Intelligent Motion Detection (IMD):

This feature shall be able to minimize the number of false alarms by eliminating environmental noise such as trees moving, ripples in water, reflection from wet roads and gain noise to name but a few. This is very different to other manufacturers that typically compare just two frames together. This camera compares 15 frames together, which ensures that only ambiguous objects moving can trigger a real alarm.

As a result, this enables end users to focus on real events, not suffer from loss of attention and quickly locate video that has been recorded upon alarm activations.
14. Distributed Enhanced Processing Architecture Advanced (DEPA Advanced):

This technology shall extend the benefits of unique conventional intelligent video analytics and enables its functionality to be used with third-party software vendors. Alternatively the camera can be configured using the web interface to be a stand-alone intelligent surveillance solution.
15. The camera shall be compliant with the Open Network Video Interface Forum Profile S (ONVIF Profile S) conformance.



B. CAMERA:

1. The camera shall utilize a 1/2.9-type progressive scan Exmor CMOS sensor.
2. The number of effective pixels shall be approx. 2.14 Megapixels.
3. The analog video output of the camera shall be selectable from either the NTSC or PAL standards.
4. Camera synchronization shall be Internal.
5. The camera shall require a minimum scene illumination of:

Color:
0.1 lx (50 IRE [IP], F 1.2, View-DR Off, VE Off, Auto gain control maximum rate MAX, 1/30s, 30 fps)
0.06 lx (30 IRE [IP], F 1.2, View-DR Off, VE Off, Auto gain control maximum rate MAX, 1/30s, 30 fps)

B/W:
0.07 lx (50 IRE [IP], F 1.2, View-DR Off, VE Off, Auto gain control maximum rate MAX, 1/30s, 30 fps)
0.05 lx (30 IRE [IP], F 1.2, View-DR Off, VE Off, Auto gain control maximum rate MAX, 1/30s, 30 fps)
6. The camera shall have an equivalent 90 dB wide dynamic range capability.
7. The video signal-to-noise ratio shall be more than 50 dB (Auto gain control maximum rate 0 dB).
8. The camera shall limit the maximum amount of gain-controlled automatic exposure control.
9. The electronic shutter speed shall be set from 1 to 1/10,000 second.
10. The camera shall adjust the target brightness for the automatic exposure setting by selecting the exposure correction value from the list box on the menu.
11. The camera shall have an Auto Iris Responding Speed function, which can adjust the speed according to a non-standard lens.
12. White balance shall be ATW (approx. 2000 K to 10000 K), ATW-PRO (approx. 2500 K to 6000 K), Indoor, Outdoor, Fluorescent lamp, Mercury lamp, Sodium Vapor lamp, Metal Halide lamp,

White LED, One push WB, or Manual settings.

The R/B gain offset can be set for the ATW or ATW-PRO settings.

13. The camera shall have a CS-mount 2.9X DC auto-iris type varifocal lens as a standard accessory.
14. The camera shall also have 4X digital zoom capability.
15. The camera shall have the total zoom ratio of 11.6X with 2.9X optical zoom and 4X digital zoom capabilities.
16. The camera shall have an Easy Focus function, which adjusts the camera focus via the Easy Focus button on the rear of the camera or remotely via the GUI.
When the camera is switched between day and night modes, the Easy Focus function is automatically activated to keep the camera focused.
17. The viewing angle in 1920 x 1080 mode (16:9 aspect ratio) shall be:
Horizontal: 114.2 ° to 40.0 °.
Vertical: 60.6 ° to 22.5 °.
18. The focal length shall be 2.8 to 8.0 mm.
19. The aperture range for the lens (F number) shall be F 1.2 (Wide) to F 1.95 (Tele).
20. The minimum object distance shall be 11 7/8 inches (300 mm).

C. CAMERA FEATURES:

1. The camera shall have a True Day/Night (D/N) function to switch to Day mode (color mode) or Night mode (black and white mode) depending on the light level.
2. The camera shall have an Image Stabilizer function, which can display with less video sway when the camera is installed in a place with vibration.
3. The camera shall have polygonal privacy zone masking which blocks out unwanted or prohibited area within the video image to protect privacy.
Mask colors shall be Black, any of 6 shades of Gray, White, Green, Yellow, Red, Cyan, Magenta, and Blue.
Mosaic patterns shall be also selected as masking.
The camera shall be capable of masking up to 20 areas.
Such capability shall be via vendor supplied SNC toolbox utility software or the browser-based setup menu.

4. The camera shall have the capability to display a wide variety of overlays in any of 7 positions on the video image (4 corners, top, bottom, or center of the image).

The following overlays shall be possible:

- Camera ID of up to 20 alphanumeric characters or a logo in gif format
- Date/Time data with selectable formats such as yyyy mm dd hh:mm:ss, mm dd yyyy hh:mm:ss, and dd mm yyyy hh:mm:ss
- User setting frame rate (fps) and bit rate (bps)
- Event -- sensor IN, unique intelligent motion detection, unique video motion filters, camera tampering detection
- Character string
- Compression format information

The following display styles shall be available: outline and transparent, white half-transparent, black half-transparent, white, and black backgrounds. Unique intelligent motion detection shall not be effective in the selected superimposed areas.

The following font colors are available: Black, Blue, Red, Magenta, Green, Cyan, Yellow and White.

All of overlays except the Date/Time data can be set to blink.

5. The camera web browser shall support the following languages: English, Japanese, French, Spanish, German, Italian, Simplified Chinese, Traditional Chinese, Korean, Portuguese, Russian, Hindi, Vietnamese, and Thai.
6. The camera shall have a Smartphone viewer, which can display the camera image and operate Pan/Tilt/Zoom (PTZ) on the smartphone.

D. VIDEO

- The supported resolutions shall be 1920 x 1080, 1280 x 720, 1024 x 576, 720 x 576 (PAL), 720 x 480 (NTSC), 704 x 576, 640 x 480, 640 x 360, 352 x 288, and 320 x 184 resolution.
- The supported resolutions are shown in the following:

Image 1 (30 fps)	Image 2 (30 fps)	Image 3 (30 fps)
1920×1080	1280×720 or lower	640×480 or lower
1280×720	1280×720 or lower	640×480 or lower
1024×576	1280×720 or lower	640×480 or lower
720×576	1280×720 or lower	640×480 or lower
704×576	1280×720 or lower	640×480 or lower
720×480	1280×720 or lower	640×480 or lower
640×480	1280×720 or lower	640×480 or lower
640×360	1280×720 or lower	640×480 or lower
352×288	1280×720 or lower	640×480 or lower
320×184	1280×720 or lower	640×480 or lower

- The camera shall support the following compression formats: JPEG and H.264 (High/Main/Baseline Profile).
- The maximum resolution for each compression format shall be 1920 x 1080.
- The camera is compliant with the SMPTE 274M in terms of number of pixels (1920 x 1080) and 16:9 format.
- The maximum frame rate at 1920 x 1080 resolution shall be 30 frames per second in H.264 (High/Main/ Baseline Profile) and 30 frames per second in JPEG. (New)
- Frame rate (fps) shall be selected among;
For NTSC (60Hz) mode: 1, 2, 3, 4, 5, 6, 8, 10, 12, 15, 20, or 30.
For PAL (50Hz) mode: 1, 2, 3, 4, 5, 6, 8, 10, 12, 15, 20, or 25.
- The camera shall have variable bitrate (VBR) or constant bitrate (CBR) encoding format selectable to correspond with various network conditions.
When VBR is selected, image quality level shall be always maintained. The bit rate shall be variable by a scene.

When CBR is selected, the storage capacity shall be calculated easily. The bit rate shall be always constant.

9. Bit rate (Kbps) shall be selected among 64, 128, 256, 384, 512, 768, 1024, 1536, 2048, 3072, 4096, 5120, 6144, 7168, 8000, 16000, 24000, or 32000.
10. The camera shall be capable of electronic pan/tilt/zoom or e-PTZ during e-PTZ mode.
11. The camera shall have an Adaptive Rate Control (ARC) function when using H.264 (High/Main/Baseline Profile) compression. This function when enabled, shall allow the camera to maintain the frame rate at a reduced image quality when network congestion occurs. Should network bandwidth become further restricted, the frame rate shall then drop automatically to a suitable speed to maintain image integrity.
12. The camera shall be capable of limiting the bandwidth from 64 kbps to 8 Mbps in H.264 (High/Main/Baseline Profile), and from 0.5 Mbps to an unlimited bandwidth in JPEG.
13. JPEG compression levels shall be user selectable in 10 levels of compression ratios, based on an image of 24 bits per picture element (8 bits each for YUV).
14. Constant bit rate algorithm for JPEG data:
The camera shall be capable of equalizing JPEG data sizes to have stable bandwidth utilization. Data size for each compression level is as follows:

Resolution	640 x 480	720 x 576	1280 x 576	1280 x 720	1920 x 1080
Image Quality Level	Data Size (KB)				
1	16	22	30	46	101
2	21	29	40	63	138
3	23	32	45	70	153
4	27	37	52	80	179
5	31	42	59	91	201
6	39	50	70	109	251
7	46	65	86	135	299
8	54	80	106	170	372
9	77	115	151	248	527
10	107	154	201	339	714

15. Actual frame rate in JPEG shall be shown in the following table:

Resolution	640 x 480	720 x 576	1280 x 576	1280 x 720	1920 x 1080
Image Quality Level	Actual Output Frame Rate (fps)				
1	30	30	30	30	30
2	30	30	30	30	30
3	30	30	30	30	30
4	30	30	30	30	20
5	30	30	30	30	20
6	30	30	30	30	20
7	30	30	30	30	15
8	30	30	30	20	12
9	30	30	20	15	8
10	30	20	15	10	4

16. The camera shall have the capability of simultaneously encoding up to 3 of the following compression formats in any combination, including multiple streams of the same format: JPEG and H.264 (High/Main/Baseline Profile).

For example, the 1st streaming shall be used for the live monitoring, the 2nd streaming shall be used for recording to the storage, and the 3rd streaming shall be used for the mobile monitoring with the smartphone viewer.

The maximum frame rates of each combination are shown in the following:

	1 st 1920x1080 8Mbps		2 nd 1280x720 4Mbps		3 rd 640x360 1Mbps	
	Codec	fps	Codec	fps	Codec	fps
Single Codec Stream	H.264	30				
Dual Codec Stream	H.264	30	H.264	30		
Triple Codec Stream	H.264	30	H.264	30	H.264	30

17. The camera shall be capable of supporting up to 20 users simultaneously over the network.

18. The camera shall have up to 6 user level settings.

The administrator shall have complete access/control of the cameras. The other 5 levels of access can be set to limit user privileges to functions such as viewing, changing image size, etc. Access to functions shall be determined as shown in the following table:

Function	Administrator	User				
		Full	Pan/Tilt	Preset position	Light	View
Monitor a live image	●	●	●	●	●	●
View the date and time	●	●	●	●	●	●
Control the frame rate (JPEG mode only)	●	●	-	-	-	-
Control the image view size	●	●	●	●	●	-
Save a still image and movie in the computer	●	●	●	●	●	-
Switch the TCP/UDP transmission mode (Available in H.264 mode only)	●	●	-	-	-	-
Receive audio	●	●	●	●	●	●
Select the codec mode	●	●	●	●	●	-
Control the setting menu	●	-	-	-	-	-

● Usable function
- Not usable function

E. INTELLIGENT VIDEO ANALYTICS:

1. The camera shall have a unique conventional intelligent video analytics named Distributed Enhanced Processing Architecture Advanced (DEPA Advanced) to trigger an alarm based on user-defined rules.
2. The camera shall incorporate a built-in unique Intelligent Motion Detection (IMD) capability.
To minimize false triggers, this Intelligent Motion Detection shall compare the current image with prior 15 frames within the camera. This algorithm shall allow the camera to discriminate against some environmental noise such as shaking leaves or Auto Gain Control maximum rate noise.
3. The camera shall have a Face Detection function which detects the locations and sizes of human faces.
It detects facial features and ignores other objects, such as buildings, trees, and bodies.

Maximum frame rate	3 fps
Maximum face size	960 x 960 pixels
Minimum face size	120 x 120 pixels
Maximum number of faces to be detected simultaneously	8 faces
Angles to be detected	<p>Yaw: $\pm 75^\circ$</p> <p>Pitch: $\pm 40^\circ$</p> <p>Roll: $\pm 30^\circ$</p>

4. The camera shall have a camera tampering detection function that alerts the operator if the camera is tampered with. Tampering can include spraying of the camera lens, covering it with a cloth, or changing of the mounting direction.
5. The camera shall have the following scene analytics, all of which can be set from the camera setup menu:
 - Intrusion: When a moving object enters the designated area, an

alarm sounds.

- Passing: A passage line is determined, and when a moving object passes the set line, an alarm sounds.
- Left Object Detection: When an object has been left unattended for too long in the designated area, an alarm sounds
- Removed Object Detection: When an object has been removed from the designated area, an alarm sounds.

F. AUDIO:

None

G. SYSTEM REQUIREMENTS & NETWORK:

1. The supported operating systems shall be Microsoft Windows 8 Pro 32 bit and 64 bit, Microsoft Windows 7 32 bit and 64 bit (Ultimate/Professional), Microsoft Windows Vista 32 bit (Ultimate/Business), Microsoft Windows XP 32 bit (Professional), and Microsoft DirectX 9.0c or higher.
2. Minimum PC requirements shall be the Intel Core i7, 2.8 GHz or higher, with 2 GB RAM or more supporting 1600 x 1200 or higher resolution, 24-bit True Color display capability with Ethernet 100Base-TX.
3. The camera shall incorporate a built-in web server, such that the standard web browser Microsoft Windows Internet Explorer (version 7.0, 8.0, 9.0 or 10.0 recommended) can be used to access the camera without need for special viewer software.
4. The following web browsers can also be used to access the camera with the plug-in free viewer: Firefox version 19.02, Safari version 5.1 and Google Chrome version 25.0.
The plug-in free viewer enables the above browsers automatically when they are started.
The plug-in free viewer display method will be selected automatically.
ActiveX viewer can allow for H.264 (High/Main/Baseline Profile) video streams and JPEG format images on the Google Chrome version 25.0.
5. The camera shall support ActiveX viewer which allows the camera image to be viewed in Internet Explorer.
The ActiveX viewer allows for recording of video and audio directly to the PC's hard drive, and supports direct audio from the PC mic to the camera.
6. The camera shall be capable of generating HTML code for the video image, allowing for easy web page integration.
7. The camera shall support the following network protocols: IPv4, IPv6, TCP, UDP, ARP, ICMP, IGMP*, HTTP, HTTPS, SSL, SMTP, DHCP, DNS, NTP, RTP/RTCP, RTSP over TCP, RTSP over HTTP, and SNMP (v1, v2c, v3).
Network security shall be via password (basic authentication) and IP filtering.

*Source-Specific Multicast (SSM) shall be supported.

8. The camera shall have the capability to stream H.264 (High/Main/Baseline Profile) video in TCP protocol or H.264 (High/Main/Baseline Profile) video in UDP (unicast/multicast) protocol.
9. The camera shall be capable of dynamic IP address change notification. It shall accomplish this via an email to a specified address or by HTTP when its IP address changes.
10. The camera shall support HTTPS client authentication.
11. The camera shall have an email (SMTP) notification capability which allows the following:
 - Sending an email to pre-specified users when an alarm is triggered by either motion detection, VMFs, camera tampering detection, audio detection or sensor input. A JPEG image, which is linked with the alarm trigger, can be attached to the email.
 - Periodically capturing a JPEG image and sending it via email.
12. The camera shall support POP3, APOP, and CRAM-MD5 authentication for SMTP transmission.
13. The camera shall support RTSP protocol based upon RFC 2326 and shall support the following options: DESCRIBE, SETUP, PLAY, TEARDOWN, and GET_PARAMETER.
14. The camera shall support QoS technology using Differentiated Services Code Point (DSCP).
15. The camera shall support IP Filtering, whereby access to the camera can be restricted to one or more groups of selected users. Up to 10 different groups can be established by defining an IP address range for each group.
16. The camera shall support IEEE 802.1X authentication, and shall:
 - comply with the IEEE 802.1X standards,
 - be capable of being integrated into an IEEE 802.1X network to achieve high network security,
 - support EAP-TLS mode to use a key pair from a Certificate Authority (CA),
 - support EAP-MD5 mode,

- support PEAP mode.

17. The camera shall have user configurable port settings.
18. Upon CGI command request, system log shall be recorded on a built-in memory (non volatile memory).
19. The camera shall provide supplied applications with the camera as a standard accessory in the CD-ROM.

The SNC easy IP setup Guide application shall provide the initial networking setting and Windows firewall configuration.

H. INTERFACES:

1. An analog monitor output for setup shall be provided, accessible from the camera control panel after the camera is installed. The interface shall be a phono jack type connector.
2. The camera shall have an RJ-45 socket on the rear of the camera. (MECHANICAL-65)
3. The network interface shall be via an 8-pin RJ-45 connector, 10Base-T/100Base-TX Ethernet. Both IPv6 and IPv4 are supported. (GENERAL-96)

I. GENERAL SPECIFICATIONS:

1. The camera input power shall be Power over Ethernet (PoE) (IEEE 802.3af compliant, Class 2).
2. Power consumption for the camera shall be 5.0 W maximum.
3. The camera operating temperature shall be within the following range:
+14 °F to +122 °F (-10 °C to +50 °C)
4. The camera starting temperature shall be within the following range:
+32 °F to +122 °F (0 °C to +50 °C)
5. The camera storage temperature shall be within the following range:
-4 °F to +140 °F (-20 °C to +60 °C)
6. The camera operating humidity shall be within the range of 20 % to 80 % (non-condensing).
7. The camera storage humidity shall be within the range of 20 % to 95 % (non-condensing).
8. The camera dimensions (W x H x D) shall be approximately:
2 7/8 x 2 1/2 x 5 3/4 inches (72 mm x 63 mm x 145 mm) (without lens and projecting parts)
2 7/8 x 2 1/2 x 7 7/8 inches (72 mm x 63 mm x 199 mm) (with lens and projecting parts).
9. The camera shall weigh approximately 1 lb 1.8 oz (505 g) with lens.
10. The external material shall be:
Top cover: SECC-CF
Bottom cover: SECC-CF
Front panel: ADC12
Rear panel: PC + ABS12.
11. The external color shall be:
Top cover: Munsell 3.6GY 8.4/0.3
Bottom cover: Munsell 3.6GY 8.4/0.3
Front panel: Munsell 3.5PB 2.2/0.4
Rear panel: Munsell 4.4BG 8.4/0.2
12. The camera shall have a mounting screw hole (1/4", 20 UNC) on both the top and bottom of the camera body for standard mounting.

J. REGULATORY SPECIFICATIONS:

1. JATE Technical standard (LAN)
2. UL2044, IEC60950-1 (CB)
3. VCCI (Class A), FCC (Class A), IC (Class A)
4. Emission: EN55022 (Class A) + EN50130-4
5. Immunity: EN55022 (Class A) + EN55024
6. Emission: AS/NZS CISPR22 (Class A)
7. KCC
8. EMC-TR

K. SUPPLIED ACCESSORIES:

1. CD-ROM (supplied programs) (1)
2. Installation Manual (1)
3. Shoulder screw M4 (1)
4. Wire rope (1)
5. Safety regulations (1)

L. OPTIONAL ACCESSORIES:

None

M. DIMENSIONS:

Front

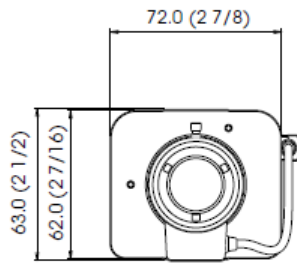

Side

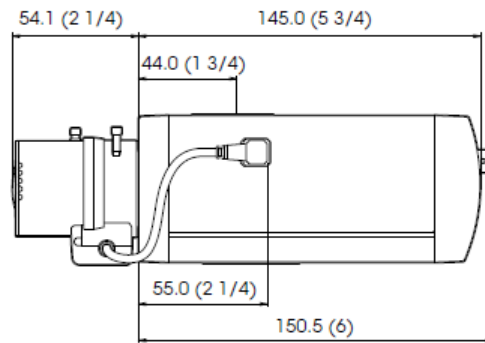

Unit: mm (inches)

©2013 Sony Corporation

Features and specifications are subject to change without notice. Non-metric weights and measurements are approximate.

Sony is a registered trademark of Sony Corporation.
IPELA, IPELA ENGINE EX, DEPA, and Exmor are trademarks of Sony Corporation.

Microsoft, Windows, Windows Vista, Internet Explorer and DirectX are either registered trademarks or trademarks of Microsoft Corporation in the United States and/or other countries.

Intel, Pentium and Intel Core are trademarks or registered trademarks of Intel Corporation or its subsidiaries in the United States and other countries.

All other trademarks are the property of their respective owners.