



ABOVE AND BEYOND HONING

ML-5000

POWER STROKED HONING MACHINES



SUNNEN'S ML-5000: A SOLUTION THAT TAKES HONING TO A WHOLE NEW



In shops around the world, Sunnen Power Stroked Honing produces work faster and with greater accuracy and consistency than I.D. grinders - especially where diameters are under 40 mm (1.57 in.). And the ML-5000 does it at a much lower cost!

Incomparable Quality - Sunnen Power Stroking assures constant stroke length and stroke rates. Combined with Automatic Size Control and a patented Dual Feed Pressure system, this means better control of bore size, finish and geometry than ever before — at high-production rates.

Saves Time And Costs By Reducing Bore Sizing Operations - With the fast stock removal rates of the Sunnen ML-5000, you can eliminate preliminary reaming, boring or grinding on many jobs. The ML-5000 allows you to rough and finish in one operation.

Run All Kinds Of Parts - The ML-5000 is one of the most versatile machine tools you can own. It handles workpieces of almost any size or configuration and cuts all kinds of materials fast and clean:

Sunnen® and the Sunnen logo are registered trademarks of Sunnen Products Company.

LEVEL OF PERFORMANCE AND EFFICIENCY



Multiple land and tandem bores: Sunnen's long stone bridges the land, keeping them all in line and the same size. No rainbow or washout.

Bores with keyways or splines: Specially designed stones and mandrels make honing keyways as easy as plain bores.

Blind end holes: Sunnen tooling is easily adapted to hone clear to the bottom of blind bores and gives you better fits than any other process.

Thin-wall parts: There are no chucks or clamps to distort or break delicate pieces. Holds tight tolerances. With the new two-stage feed pressure, thin-wall parts can be honed quickly with minimal distortion of the finished bore.

Heavy or odd-shaped parts: They don't have to be chucked or swung or precisely located. A simple, easy-to-make holding fixture does the trick in most cases.



Your Sunnen Technical Specialist will work with you to determine the best solution for your needs – it's all part of the added value you get with Sunnen. Plus, our worldwide sales and service team provides comprehensive support for the installation and operation of every system we make.

Whatever your need, we have the expertise and product range to create the right solution for you and the dedication to support you for the long run.

To find the Sunnen representative nearest you, visit our website:
www.sunnen.com



THE ML-5000 MAKES JOBS EASY

WORKHOLDING FIXTURES FOR EVERYDAY APPLICATIONS

*THE UNIVERSAL HONING FIXTURE
COMES STANDARD WITH THE
MACHINE, AND CAN BE USED FOR
MOST HONING APPLICATIONS.*



*THE ML-5000 CAN ALSO BE EQUIPPED WITH
FIXTURES DESIGNED FOR YOUR APPLICATION,
SUCH AS THE GIMBAL/POCKET FIXTURE.*

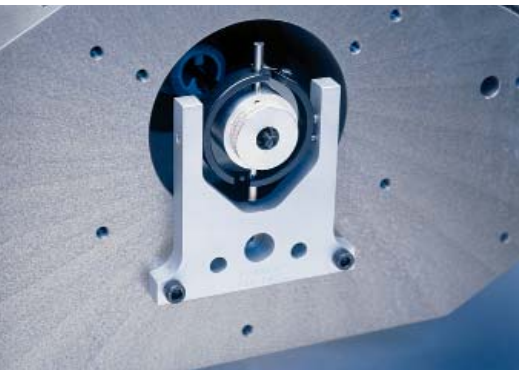

Sunnen Power Stroking assures constant stroke length and stroke rates. Combined with Automatic Size Control and a patented Dual Feed Pressure system, this means better control of bore size, finish and geometry than ever before – at high-production rates.

Job after job in all kinds of shops, Sunnen Power Stroked Honing is producing work up to six times faster and with greater accuracy and consistency than I.D. grinding and other honing processes – especially when diameters are under 40 mm (1.57 in.). Plus, setup takes half the time and you get better bore geometry, a desirable oil-bearing cross-hatch finish and longer tool life.

With the fast stock removal rates of the Sunnen ML-5000, you can eliminate preliminary reaming, boring or grinding on many jobs. The ML-5000 allows you to rough and finish in one operation, saving time and money.

The ML-5000 is extremely versatile. It handles workpieces of almost any size or configuration and cuts all kinds of materials fast and clean.

SETUP IS FAST AND EASY -

Complete setup is handled from the front of the machine without raising a cover. Universal honing fixtures handle nine out of ten jobs.

There are no chucks or fixtures or special tooling. No critical alignment to worry about. Feed rates, stroke length and stroke speed are set and locked in. The chance for human error is greatly reduced. Complete setup is handled from the front of the machine without raising a cover. Universal honing fixtures handle nine out of ten jobs.

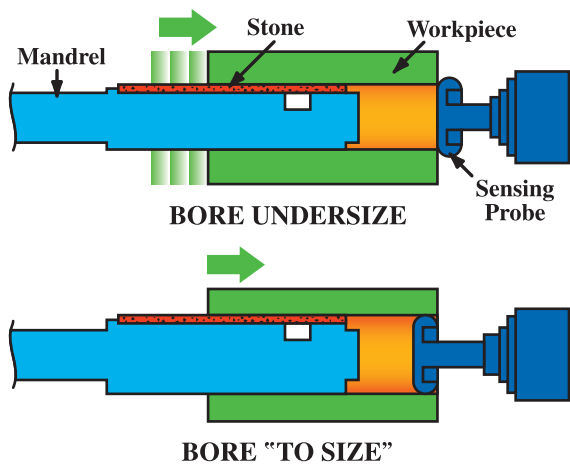

AUTOMATIC STONE WEAR COMPENSATOR

Automatic Stone-wear Compensator
The operator can set the feedup control to compensate for stone-wear automatically during each cycle, improving ease of operation and increasing production.

FEED REGULATOR SYSTEM

For special applications, the feed regulator system can be used to improve stone life or to set the machine to a constant feed rate.



AUTOMATIC SIZE CONTROL (OPTIONAL)

Simply set the diameter of the sensing probe slightly smaller than the finish diameter of the bore being honed. As soon as the bore is "to size," the sensing probe slips into the bore. The stroking circuit is de-energized and the honing cycle stops automatically.

MAXIMUM FEED PRESSURE FLEXIBILITY

Maintains accuracy and improves cycle time. Pressure settings range from 1 to 16. With the new two-stage feed pressure feature, the operator can reduce cycle time by removing the bulk of the stock at a high feed pressure and finish at a lower pressure. The operator selects the stock removal and pressure for each stage.

The ML-5000 Assures Faster Cycle Times, Easier Operation and Precise Bore Geometry.

Low-cost, Adjustable Probes -

Sensing probes are adjustable so you can set size exactly where you want it - high, low or in the middle of your tolerance range. You can use the same sensing probe for rough and finish honing.

Automatic Size Control compensation allows fine tuning of size by adding extra strokes after the probe enters the bore. More effective targeting of the nominal diameter delivers better process control (larger Cpk).

A full range of Sensing Probes - diameters 3,18 mm - 25,8 mm (1/8 in. - 1-1/64 in.) - plus adjustable Sensing Units and Setting Fixture for diameters 26 mm - 51 mm (1 in. - 2 in.) - are all stocked and ready for immediate delivery.

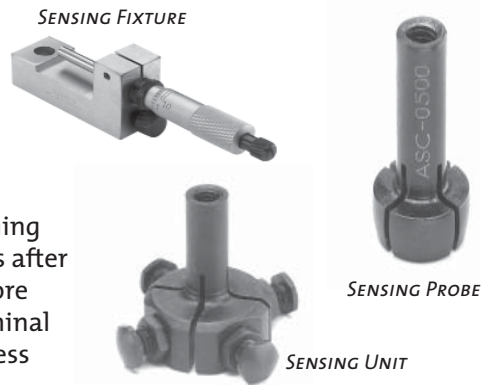

MORE FEATURES ON THE ML-5000:

Rigid Machine Base - Reinforced structural steel and cast iron provides a solid machining platform. Moving components are isolated from the base to eliminate vibration problems.

Electronic Control System - Vertical control panel allows easier use. There are no exposed contacts or switches to maintain. A sealed control box, completely outside the work area, protects circuitry from dirt and coolants.

Detachable Coolant Cart - The unique coolant reservoir is mounted on casters so it can be rolled out to provide room for stroking long parts. It is a self-contained unit with all components a free-standing unit would have.

SPECIFICATIONS:

Note: Models available for both metric (SI) or inch (USCS) usage.

Please specify when ordering.

Diameter Range (ID):

Manual Stroking*: 1,5 – 165,1 mm (.060 – 6.500 in.)

Power Stroking*: 1,5 – 101,6 mm (.060 – 4.000 in.)

Automatic Sizing:** 3,2 – 51,0 mm (1.25 – 2.000 in.)

Stroke Length: 6,0 – 170 mm (.236- 6.700 in.)

Spindle Speeds: 200 to 3000 RPM (adjustable in fine increments)

Stroke Rate: 60 to 500 SPM

Spindle Motor: 4,1 kW (5.5 HP)

Stroker Motor: 1,1 kW (1.5 HP)

Pump Motor: .036 kW (1/2 HP)

Coolant Pump: 11.2 Liters/Minute (3 Gallons/Minute)

Coolant Capacity: 120 Liters (32 Gallons)

Coolant Filtration: Cartridge Filter, 5 or 10 micron

Floorspace**:

Depth: 1,6 m (64 in.)

Width: 1,22 m (48 in.)

Height: 1,9 m (75 in.) with covers open

(Less Coolant Cart): 725 kg (1,600 lbs.)

Coolant Cart Weight (Dry): 125 kg (275 lbs.)

Machine Weight**:

Power Requirements:

3-Phase, 50/60 HZ (maximum current load 30 amps) 230V, or 3-phase, 0/60 Hz (maximum current load 15 amps) 400V. Optional 460V to 230V transformer available.

Pneumatic Requirements: 5,5 Bar (80 psi)

*Contingent on application

**Floor space and weight of ML-5000 dependent on optional fixturing system ordered.

ML-5000 TOOLING, ABRASIVES HONING OILS AND COOLANTS

ORDERING INFORMATION:

ML-5000 Automated Honing System includes universal workholding fixture, detachable coolant cart with dual remote cycle start buttons, stroker positioning unit, stroker stop and magazine proximity switch, electronic package, and software for the standard loading package.

OPTIONAL EQUIPMENT:

(to be ordered as needed)

- EC-4500 Automated Size Control
- EC-4485 Gage Bracket
- Specialized Workholding Fixture
- Specialized Software
- Magazine or Delivery System
- Workpiece Loading Fingers

For tooling , abrasives, honing fluids, gages and accessories, please ask for Sunnen Supplies Catalog X-SP-5500 or visit www.Sunnen.com/Catalogs



TOOLING

The ML-5000 incorporates the latest technology in horizontal honing. Sunnen offers a wide range of tooling options from multi-stone mandrels to standard mandrels.

MMT HIGH-PRODUCTION MULTI-STONE MANDRELS

MMT mandrels offer faster cycle times, superior accuracy, longer time between stone changeovers, and maintain superior bore geometry and bore centerline. Every mandrel is manufactured using high-strength steel to ensure long production life.

BORE DIAMETER RANGE (I.D.): 4 mm - 65 mm (0.156 in. - 2.56 in.)*

SRT MULTI-STONE TOOLS

SRT multi-stone honing tools are known for their dependability for both production and high precision applications. Each uses a series of seven stone holder types, featuring replaceable abrasives to reach the specified diameter range.

BORE DIAMETER RANGE (I.D.): 35 mm – 102 mm (1.4 in. - 4.0 in.)*

STANDARD MANDRELS

For bores under 150 mm (6 inch) in diameter, the industry standard Sunnen mandrels provide straightness and roundness with minimum stock removal. Standard mandrels can be supplied for blind hole honing, with multiple stones for honing long bores.

BORE DIAMETER RANGE (I.D.): 1,5 mm - 165 mm (.06 in. - 6.5 in.)*

* FOR DIAMETER SIZES BELOW OR ABOVE THE STANDARD RANGE, OR FOR SPECIALLY DESIGNED TOOLS, CONTACT YOUR SUNNEN FIELD ENGINEER.

SUNNEN ABRASIVES

From aluminum oxide to silicon carbide to diamond and CBN, Sunnen manufactures the industry's largest variety of mounted or un-mounted stick abrasives, bond types, grain sizes and stone configurations.



Before any stone is shipped, it is graded and qualified, maintaining the most exacting quality control standards in the industry to assure you of the most precise honing performance available.

GET THE PRECISION YOU NEED WITH SUNNEN PREMIUM HONING OILS AND COOLANTS

Sunnen's premier line of honing oils and coolants provide extreme lubricity for higher honing pressure and harder abrasives, delivering faster, lower cost-per-part and ultimately more profitable cutting rates.



A LEGACY OF EXCELLENCE SINCE 1924.

WORLDWIDE

Our global manufacturing, distribution, and sales and service network allows us to deliver quality Sunnen solutions worldwide.

And our state-of-the-art Technical Services Centers allow our technical experts to develop innovative solutions to customer application challenges. The Centers also provide answers for customer questions and training for Sunnen representatives around the world.

SUNNEN PRODUCTS COMPANY

World Headquarters
St. Louis, MO – USA
Phone 1.314.781.2100
Fax 1.314.781.2268
Toll Free 1.800.325.3670
Email sunnen@sunnen.com
www.sunnen.com

SWITZERLAND – SUNNEN AG

Phone +41 71 649 33 33
Fax +41 71 649 33 34
Email info@sunnen.ch
www.sunnen.ch

ITALY – SUNNEN ITALIA S.R.L.

Phone +39 02 383 417 1
Fax +39 02 383 417 50
Email sunnen@sunnenitalia.com
www.sunnenitalia.com

FRANCE – SUNNEN SAS

Phone +33 01 69 30 0000
Fax +33 01 69 30 1111
Email info@sunnen.fr
www.sunnen.fr

BELGIUM – SUNNEN BENELUX BVBA

Phone +32 38 80 2800
Fax +32 38 44 3901
Email info@sunnen.be
www.sunnen.be

UK – SUNNEN PRODUCTS LTD.

Phone +44 1442 39 39 39
Fax +44 1442 39 12 12
Email hemel@sunnen.co.uk
www.sunnen.co.uk

POLAND – SUNNEN POLSKA SP. Z O.O.

Phone +48 22 814 34 29
Fax +48 22 814 34 28
Email sunnen@sunnen.pl
www.sunnen.pl

RUSSIA – SUNNEN RUS

Phone +7 495 258 43 43
Fax +7 495 258 91 75
Email sunnen@sunnen-russia.ru
www.sunnen.ru

CZECH REPUBLIC – SUNNEN S.R.O.

Phone +420 383 376 317
Fax +420 383 376 316
Email sunnen@sunnen.cz
www.sunnen.cz

CHINA – SHANGHAI SUNNEN MECHANICAL CO. LTD.

Phone +86 21 5813 3990
Fax +86 21 5813 2299
Email shsunnen@sunnensh.com
www.sunnensh.com

SUNNEN AND THE SUNNEN LOGO ARE REGISTERED TRADEMARKS OF SUNNEN PRODUCTS COMPANY

Sunnen reserves the right to change or revise specifications and product design in connection with any feature of our products contained herein. Such changes do not entitle the buyer to corresponding changes, improvements, additions, or replacements for equipment, supplies or accessories previously sold. Information contained herein is considered to be accurate based on available information at the time of printing. Should any discrepancy of information arise, Sunnen recommends that user verify the discrepancy with Sunnen before proceeding.

