



INSTALLATION INSTRUCTIONS FOR PART 99-2003

APPLICATIONS

See application list inside

GM/Suzuki multi-kit 1990-up 99-2003/AT-555GM/AW-555GM

KIT FEATURES

- DIN head unit provision with pocket
- Double DIN head unit provision
- Stacked ISO head unit provision



KIT COMPONENTS

- A) Radio housing with pocket
- B) ISO trim plate
- C) DDIN trim plate
- D) DDIN stacked ISO brackets
- E) DIN Spacer
- F) ISO Snap-in brackets
- G) Carriage bolts
- H) KEP nuts
- I) (3) Screws with speed clips

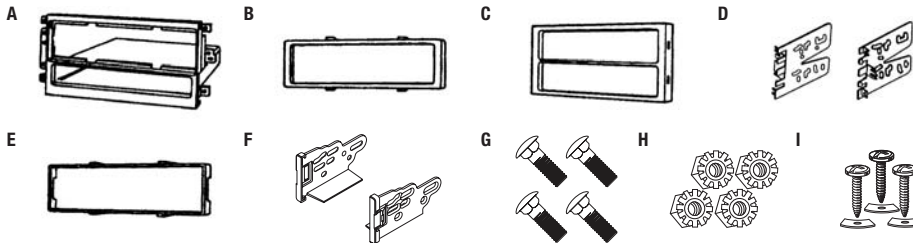

WIRING & ANTENNA CONNECTIONS (sold separately)

Wiring Harness:

- Visit www.metraonline.com for specific interface applications

Antenna Adapter:

- 40-GM10 - GM antenna adapter 1988-up
- 40-CR10 - Chrysler antenna adapter 2002-up

TOOLS REQUIRED

- Utility knife
- Phillips screwdriver
- Socket set

CAUTION: Metra recommends disconnecting the negative battery terminal before beginning any installation. All accessories, switches, and especially air bag indicator lights must be plugged in before reconnecting the battery or cycling the ignition.

NOTE: Refer to the instructions included with the aftermarket radio.



99-2003

Applications

Buick

Century	1997-2005
Le Sabre	1995-2005
Park Avenue	1995-2005
Rainier	2004-2007
Regal	1995-2004
Rendezvous	2002-2007
Riviera	1996-1999
Roadmaster	1995-1996
Skylark	1996-1998

Cadillac

Escalade ESU/EXT	2003-2006
Fleetwood/ Brougham	1990-1996

Chevrolet/Geo

Avalanche	2003-2006
Blazer (with DDIN).....	2002-2005
Cavalier	2000-2005
Colorado	2004-2012
Express Van (full size).....	2001-2007
Impala	2000-2005
Kodiak	2003-2009
Malibu	2001-2003
Malibu Classic	2004-2005
Metro (Geo included)	1995-2001
Monte Carlo	2000-2005
SSR	2003-2006

Chevrolet (continued)

S-10 (with DDIN).....	2002-2004
Silverado Classic	2003-2007
Suburban	2003-2006
Tahoe	2003-2006
Tracker (GEO included).....	1992-2004
Trailblazer	2002-2009
Venture	2000-2005

GMC

Canyon	2004-2012
Envoy	2002-2009
Savana (full size)	2001-2007
Sierra Classic	2003-2007
Sonoma (with DDIN).....	2002-2004
Top Kick.....	2005-2009
Yukon/Yukon Denali/XL	2003-2006

Hummer

H2	2003-2007
----------	-----------

Isuzu

Ascender	2003-2008
i280/i350	2006
i290/i370.....	2007-2008

Oldsmobile

Achieva	1996-1998
Alero	1999-2004
Aurora	1995-2003

Oldsmobile (continued)

Bravada	1998-2001
Bravada	2002-2004
Cutlass	1997-1999
Cutlass Supreme	1995-1997
Eighty-Eight	1994-1999
Intrigue	1998-2002
LSS	1996-1999
Ninety-Eight	1994-1996
Regency	1997-1998
Silhouette	2000-2004

Pontiac

Aztec	2001-2005
Bonneville	2000-2005
Grand Am	2001-2005
Montana	2000-2005
Sunfire	2000-2005

Suzuki

Aerio	2002
Esteem	1995-2003
Grand Vitara.....	1999-2002
Sidekick	1992-1998
Swift	1995-2001
Vitara	1999-2004
XL-7	2001-2002

Table of Contents

Dash Disassembly

Buick

- Century 1997-2005	4
- Le Sabre 1995-2005.....	4
- Park Avenue 1995-2005	4
- Rainier 2004-2007.....	12
- Regal 1995-2004.....	4
- Rendezvous 2002-2007.....	5
- Riviera 1996-1999.....	5
- Roadmaster 1995-1996.....	6
- Skylark 1996-1998	6

Cadillac

- Escalade ESU/EXT 2003-2006	6
- Fleetwood/Brougham 1990-1996.....	7
- Radio Bracket Disassembly (Fleetwood/Brougham).....	7

Chevrolet

- Avalanche 2003-2006	6
- Blazer 2002-2005	8
- Cavalier 2000-2005	8
- Colorado 2004-2012	8
- Express Van (full size) 2001-2002	9
- Express Van (full size) 2003-2007	9
- Impala 2000-2005	10



Dash Disassembly 99-2003

Table of Contents

Chevrolet (continued)

- Kodiak 2003-2009	6
- Malibu 2001-2003	10
- Malibu Classic 2004-2005	10
- Metro (Geo included) 1995-2001	10
- Monte Carlo 2000-2005	11
- SSR 2003-2006	11
- S-10 (with DDIN) 2002-2004	11
- Silverado Classic 2003-2007	6
- Suburban 2003-2006	6
- Tahoe 2003-2006	6
- Tracker (Geo included) 1992-2004	12
- Trailblazer 2002-2009	12
- Venture 2000	12
- Venture 2001-2005	13

GMC

- Canyon 2004-2012	8
- Envoy 2002-2009	14
- Savana 2001-2002	9
- Savana 2003-2007	9
- Sierra Classic 2003-2007	6
- Sonoma (with DDIN) 2002-2004	8
- Top Kick 2005-2009	6
- Yukon/Yukon Denali/XL 2003-2006	6

Hummer

- H2 2003-2007	13-14
----------------------	-------

Isuzu

- Ascender 2003-2009	14
- i280/i350	8
- i290/i370	8

Oldsmobile

- Achieva 1996-1998	15
- Alero 1999-2004	15
- Aurora 1995-2003	15
- Bravada 1998-2001	8
- Bravada 2002-2004	14
- Cutlass 1997-1999	16
- Cutlass Supreme 1995-1997	16
- Eighty-Eight 1994-1999	16
- Intrigue 1998-2002	16
- LSS 1996-1999	17
- Ninety-Eight 1994-1996	16
- Regency 1997-1998	17
- Silhouette 2000	12
- Silhouette 2001-2004	13

Pontiac

- Aztec 2001-2005	17
- Bonneville 2000-2005	18
- Grand Am 2001-2005	18
- Montana 2000	12
- Montana 2001-2005	13
- Sunfire 2000-2005	19

Suzuki

- Aerio 2002	19
- Esteem 1995-2003	19
- Grand Vitara 1999-2002	12
- Sidekick 1992-1998	12
- Swift 1995-2001	10
- Vitara 1999-2004	12
- XL-7 2001-2002	12

Tab Instructions

- All Vehicles, Single DIN	20
- All Vehicles, Double DIN	21

Kit Assembly

- DIN head unit provision with pocket	20-21
- Double DIN head unit provision	22
- Stacked ISO head unit provision	22-23



Dash Disassembly 99-2003

Buick Century 1997-2005 Buick Regal 1995-2004

1. Remove the plastic trim piece to the left of the glove box and (1) Phillips screw exposed.
2. Unsnap the top edge of the knee bolster panel. (Figure A)
3. Remove (1) Phillips screw from the panel.
4. Remove the ashtray cluster and (2) Phillips screws from each side.
5. Unclip the entire dash trim bezel and remove.
6. Open doors and unsnap end caps from each side of dash.
7. Unsnap and remove radio/instrument cluster panel.
8. Remove (3) screws in order to remove radio.

Continue to tab instructions

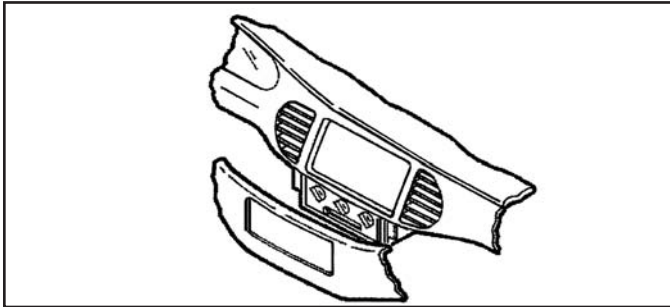

Buick Le Sabre 1995-1999 Buick Park Avenue 1995-1999

1. Unsnap the climate control trim panel (from door to door) and remove (4) Phillips screws exposed.
2. Pop out the A/C vents and remove (1) Phillips screw exposed in each vent cavity.
3. Unclip the radio trim bezel and remove.
4. Remove the screws securing the factory head unit and disconnect the wiring.

Continue to tab instructions

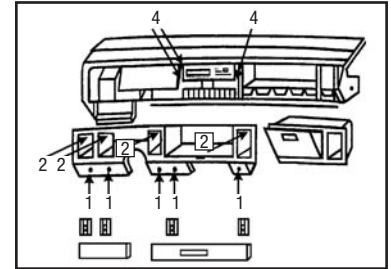

Buick Le Sabre 2000-2005 Buick Park Avenue 2000-2005

1. Open drivers door and unsnap and remove dash end cap. (Figure A)
2. Remove (2) Phillips screws from underneath steering column cover.
3. Unsnap and remove steering column cover.
4. Unsnap and remove instrument panel.
5. Remove (2) 9/32" screws and remove radio.

Continue to tab instructions

Note: For the Buick Le Sabre, Oldsmobile Aurora and the Pontiac Bonneville the (3) speed clips and screws provided with the kit will need to be installed into the sub dash where the screw holes line up on the kit.

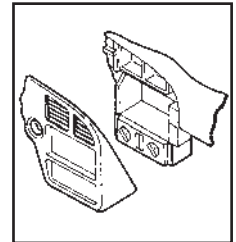

(Figure A)

Buick Rendezvous 2002-2007

1. Open center console and remove (2) screws at front of console opening. (Figure A)
2. Remove liners from cup holders and storage pocket next to cup holders, then remove screws. Unsnap and remove panel. (Figure B)
3. Remove (2) screws from bottom of radio/climate control bezel, unclip and remove. (Figure C)
4. Remove (3) 9/32" hex-head screws to remove radio. (Figure D)

Continue to tab instructions

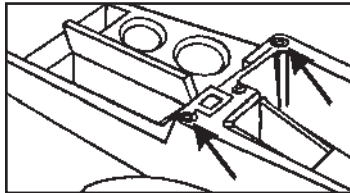

(Figure A)

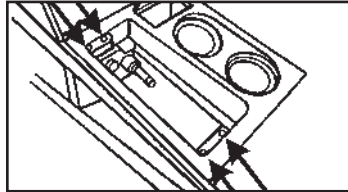

(Figure B)

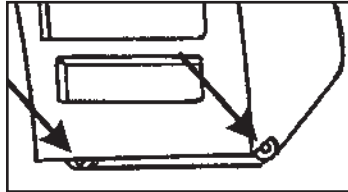

(Figure C)

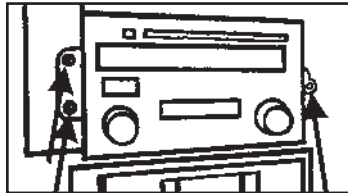

(Figure D)

Buick Riviera 1996-1999

1. Unsnap left side panel exposing (1) Phillips screw to remove.
2. Remove (1) Phillips screw and unsnap right side panel to expose (1) Phillips screw beneath panel and remove.
3. Unsnap underside of overhanging dash to unsnap (6) plastic rivets and remove panel.
4. Remove (5) hex-head screws now exposed under overhang.
5. Unsnap bottom edge of trim bezel, then while holding overhang up, unsnap and remove trim bezel by removing any necessary harnesses.
6. Remove (3) Phillips screw to remove climate control.
7. Remove (2) Phillips screws to remove rear support and (3) 9/32" hex-head screws to remove radio.

Continue to tab instructions

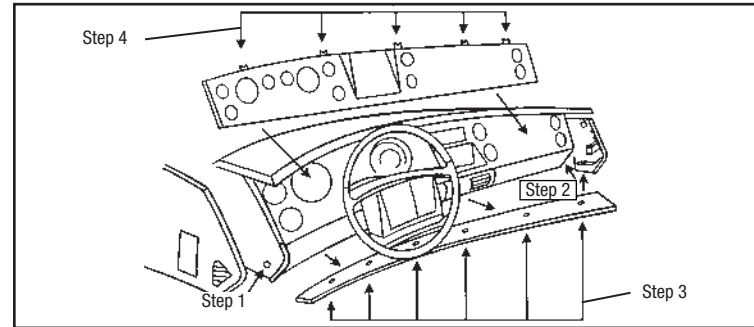



Dash Disassembly 99-2003

Buick Roadmaster 1995-1996

1. Unclip dash panel sides and remove.
2. Unclip panel below steering column and remove.
3. Remove (2) 7mm screws above instrument cluster.
4. Set parking brake, turn car on, and move shifter to the lowest gear. Tilt steering wheel down then unsnap entire instrument cluster/radio panel and remove.
5. Remove (3) 7mm screws to remove radio.

Continue to tab instructions

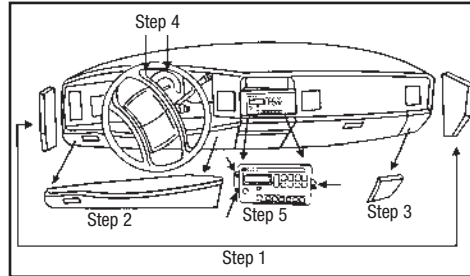

Buick Skylark 1996-1998

1. Remove (6) 9/32" screws inside glove box.
2. Under glove box and drivers knee bolster, remove (2) plastic panels by turning (2) 1/4 turn fasteners per side.
3. Remove (4) 9/32" screws that are revealed (2 per side).
4. Unsnap panel from driver's side to passenger's side.
5. Remove (3) 9/32" screws to remove radio.

Continue to tab instructions

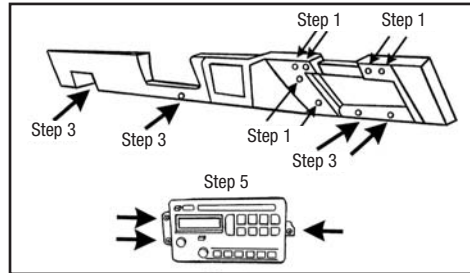

Cadillac Escalade ESU/ EXT 2003-2006, Chevrolet Avalanche 2003-2006/ Kodiak 2003-2009/ Silverado Classic 2003- 2007/Suburban 2003-2006/ Tahoe 2003-2006, GMC Sierra Classic 2003-2007/ Top Kick 2005-2009, GMC Yukon/Yukon Denali/XL 2003-2006

1. Unsnap and remove dash bezel. (Figure A)
2. Remove (3) 9/32" screws and remove radio.

Continue to tab instructions

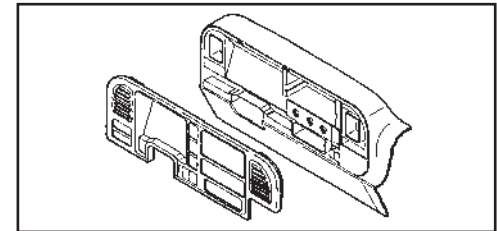

(Figure A)



Dash Disassembly 99-2003

Cadillac Fleetwood/Fleetwood Brougham 1990-1996

1. Carefully unsnap trim panel above A/C controls. (Figure A)
2. Remove (2) 7mm screws at the top of the radio/air conditioning bezel, then unclip panel and remove. (Figure B and C)
3. Remove (4) 7mm screws that hold the radio in, slide radio out, unplug the radio harnesses and remove radio. (Figure D)

Continue to radio bracket disassembly (right side, page 7)

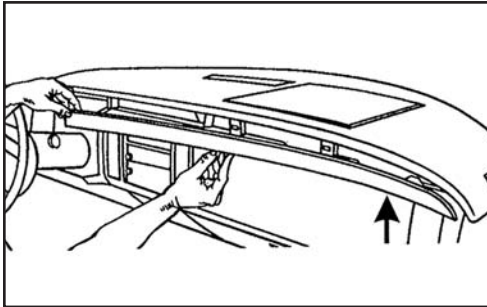

(Figure A)

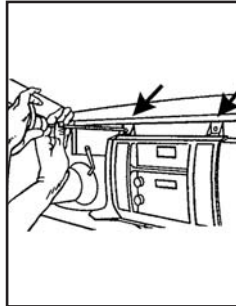

(Figure B)

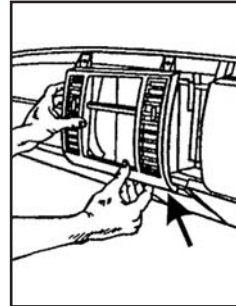

(Figure C)

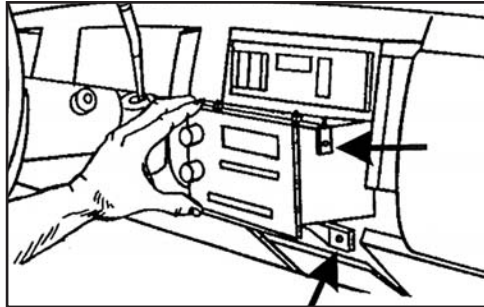

(Figure D)

Radio Bracket Disassembly

1. Remove (4) 10mm nuts, (2) on top of the radio and (2) on the bottom of the radio, that hold the factory mounting brackets on. Save brackets and nuts for use in kit assembly. (Figure A)

Continue to tab instructions

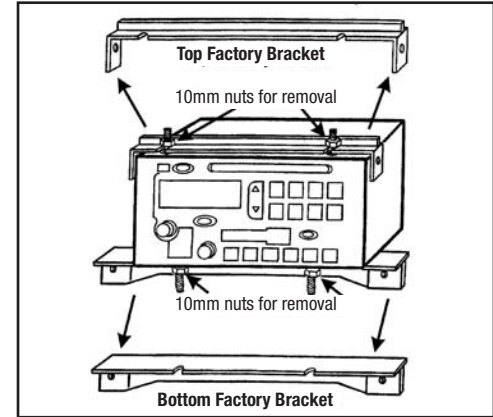

(Figure A)



Dash Disassembly 99-2003

Chevrolet Blazer 2002-2005/5-10 (with DDIN) 2002-2004, GMC Sonoma (with DDIN) 2002-2004, Oldsmobile Bravada 1998-2001

1. Remove (2) 9/32" hex-head screws from the knee bolster panel. (Figure A)
2. Pull down on the panel and remove the 9/32" hex-head screws exposed on the bottom of the dash trim bezel.
3. Remove (1) Phillips screw above the instrument cluster.
4. Unclip the dash trim bezel and remove.
5. Remove (2) 9/32" hex-head screws securing the factory head unit and disconnect the wiring.

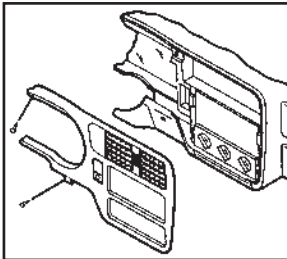

(Figure A)

Chevrolet Cavalier 2000-2005

1. Open drivers door and remove fuse panel on end of dash.
2. Open passenger door and remove panel on end of dash.
3. Remove (1) Phillips screw from each side exposed.
4. Remove (3) screws from top of glove box liner.
5. Remove (2) screws from the top-left corner of the glove box cavity.
6. Remove (1) Phillips screw from the defroster duct.
7. Remove the duct work and (1) Phillips screw exposed.
8. Remove the dash pad and (3) Phillips screws exposed at the top of the radio trim bezel.

Continue to tab instructions

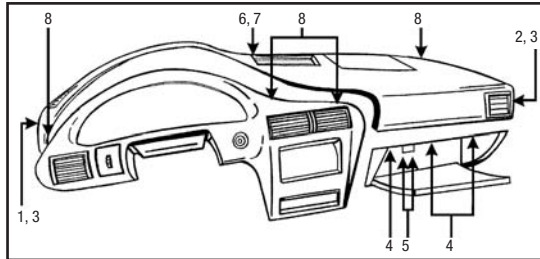

Chevrolet Colorado/GMC Canyon 2004-2012, Isuzu i280/i350 2006 i290/i370 2007-2008

1. Unsnap and remove the entire panel surrounding the radio and A/C controls. (Figure A)
2. Remove (3) 9/32" screws securing the radio to remove. (Figure B)

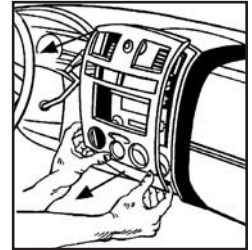

(Figure A)

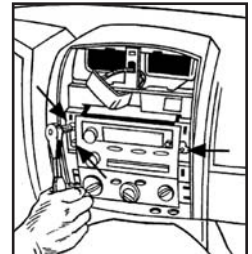

(Figure B)

Continue to tab instructions



Dash Disassembly 99-2003

Chevrolet Express Van/GMC Savana 2001-2002

1. Unsnap and remove small trim panel below steering column. (Figure A)
2. Unsnap radio/climate/instrument panel. (Figure B)
3. Move shift lever to first gear position.
4. Rotate panel counterclockwise to lift over steering column and remove.
5. Remove (3) 9/32" hex-head screws to remove radio. (Figure C)

Continue to tab instructions

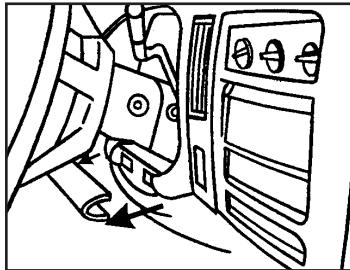

(Figure A)

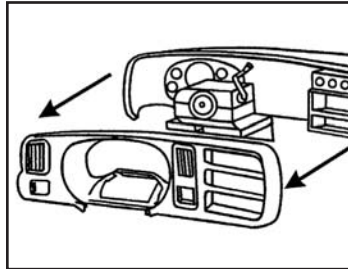

(Figure B)

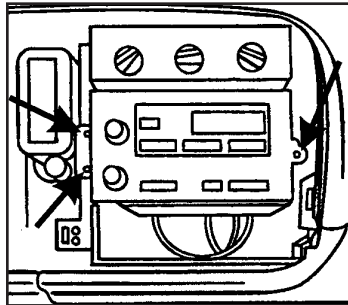

(Figure C)

Chevrolet Express Van 2003-2007 GMC Savana 2003-2007

1. Remove (2) 10mm bolts from below knee bolster under steering column and remove panel. (Figure A)
2. Remove (2) 10mm bolts from panel below passenger dash airbag and remove panel. (Figure B)
3. Remove (2) 10mm nuts from inside center pocket between power outlets. (Figure C)
4. Unsnap and remove radio and instrument cluster panel. (May not be necessary to completely remove radio and instrument cluster panel to access radio.)
5. Remove (3) 9/32" bolts to remove radio. (Figure D)

Continue to tab instructions

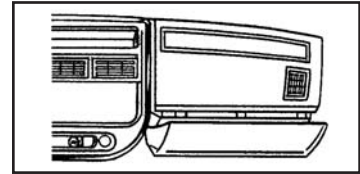

(Figure B)

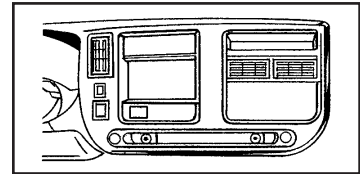

(Figure C)

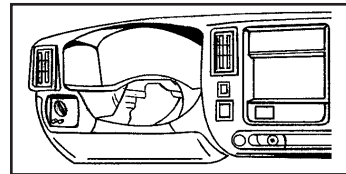

(Figure A)

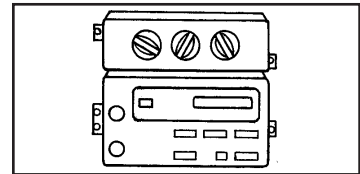

(Figure D)



Dash Disassembly 99-2003

Chevrolet Impala 2000-2005

1. Unclip each side of the dash trim bezel (fuse access) and remove (1) Phillips screw exposed on each side.
2. Remove (2) Phillips screws under the instrument cluster.
3. Unclip the trim panel above the pedals. (It is not necessary to remove the panel it can be left hanging).
4. Remove (2) Phillips screws from the knee panel.
5. Unclip the knee panel and remove (1) Phillips screw exposed on the right side of the steering column.

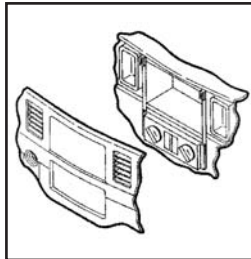

(Figure A)

Continue to tab instructions

Chevrolet Malibu 2001-2003, Chevrolet Malibu Classic 2004-2005

1. Unsnap and remove radio bezel.
2. Remove (3) bolts and remove radio.

Continue to tab instructions

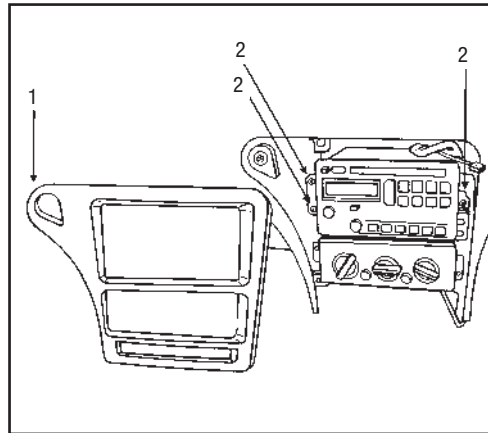

Chevrolet Metro/Suzuki Swift 1995-2001

1. Remove the ashtray and (2) Phillips screws exposed. (Figure A)
2. Remove (2) Phillips screws above the radio opening. (Figure A)
3. Unclip the radio trim bezel and disconnect the cigarette lighter wiring.
4. Remove (2) screws securing each side of the factory head unit and (1) screw from the rear support.
5. Slide the unit out and disconnect the wiring.

Continue to tab instructions

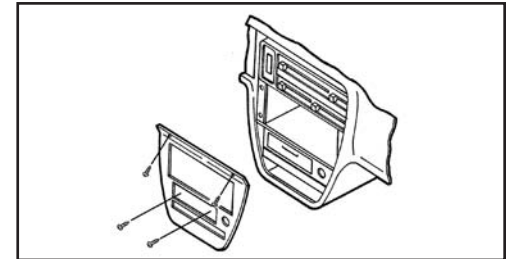

(Figure A)



Dash Disassembly 99-2003

Chevrolet Monte Carlo 2000-2005

1. Unclip the trim panel above the pedals
(it is NOT necessary to completely remove panel, it may be left hanging). (Figure A)
2. Remove (2) 9/32" screws from the knee panel and unclip the panel.
3. Unsnap the driver's side fuse panel cover and remove (1) 9/32" screw.
4. Open the glove box and remove (1) 9/32" screw from the upper left corner.
5. Remove (3) 9/32" screws securing the factory radio and disconnect the wiring.

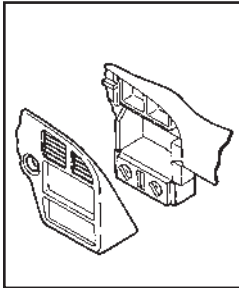

(Figure A)

Continue to tab instructions

Chevrolet SSR 2003-2006

1. Unclip and remove the (3) climate control knobs.
(Figure A)
2. Unclip and remove the long trim panel below the radio and passenger air bag. (Figure B)
3. Unclip and remove the small trim panel to the left of the steering wheel. (Figure C)
4. Remove the (5) 9/32" screws securing the radio/instrument panel then unclip and remove the panel. (Figure D)
5. Remove the screws securing the factory head unit and disconnect the wiring.

Continue to tab instructions

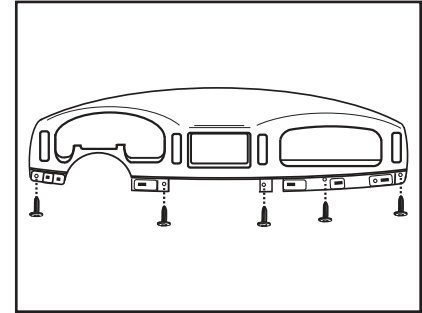

(Figure D)

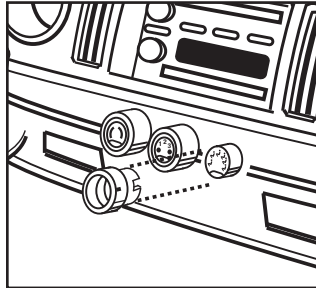

(Figure A)

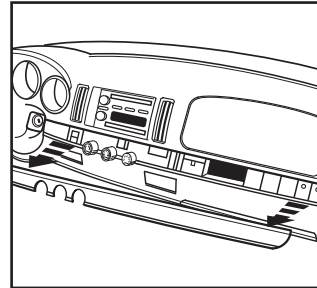

(Figure B)

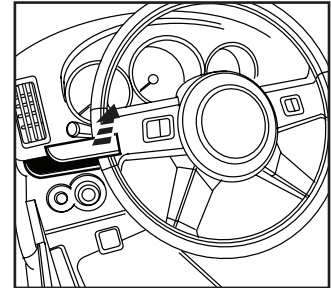

(Figure C)



Dash Disassembly 99-2003

Chevrolet Tracker *(Geo included)* **1992-2004, Suzuki Sidekick 1992-1998, Suzuki Vitara 1999-2004/Grand Vitara 1999-2002/XL-7 2001-2002**

1. Remove the cigarette lighter and climate control knobs.
2. Remove the ashtray and (1) screw exposed. (Figure A)
3. Pull out on the climate control cluster and remove (2) screws exposed. (Figure A)
4. Unclip the radio trim bezel.
5. Remove (4) screws from the factory head unit, slide the unit out and disconnect the wiring.

Continue to tab instructions

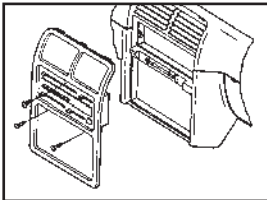

(Figure A)

Chevrolet Trailblazer 2002-2009

1. Remove (2) Phillips screws inside instrument cluster.
2. Remove (1) Phillips screw under climate controls to the left of the power outlet.
3. Remove (2) 7mm hex-heads from under steering column and lower the panel. Remove (3) Phillips screws around steering wheel.
4. Unsnap and remove bezel. *(Use caution pulling over hazard switch.)* Remove (3) 7mm hex-head screws to remove radio.

Continue to tab instructions

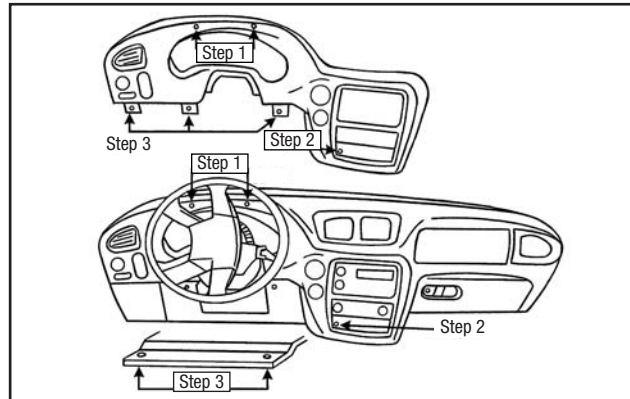

Chevrolet Venture/ Oldsmobile Silhouette/Pontiac Montana 2000 *(Except SV6)*

1. Remove the ashtray and (1) Phillips screw exposed in the ashtray cavity.
2. Remove (1) Phillips screw from the cigarette lighter compartment.
3. Remove (2) Phillips screws securing the factory head unit and disconnect the wiring.

Continue to tab instructions

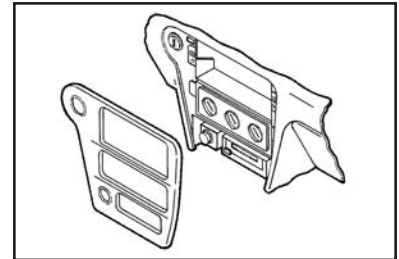



Dash Disassembly 99-2003

Chevrolet Venture 2001-2005 Oldsmobile Silhouette 2001-2004 Pontiac Montana 2001-2005

1. Open cup holders and remove (2) Phillips 7mm screws. (Figure A)
2. Unsnap and remove dual power outlet assembly from lower storage.
3. Open lower storage door and remove (2) 7mm screws inside.
4. **Models with DVD** - Remove DVD player and remove (2) 7mm screws from behind and (2) 7mm screws near the floor.
5. Remove lower storage compartment. (Figure B)
6. Remove (2) 7mm screws (facing up) from under cup holder. (Figure C)
7. Remove (3) 7mm hex-head screws and remove radio. (Figure D)

Continue to tab instructions

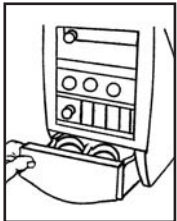

(Figure A)

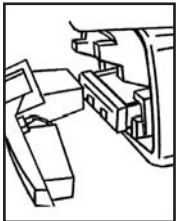

(Figure B)

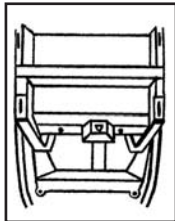

(Figure C)

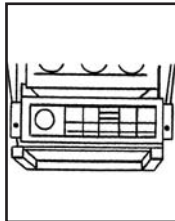

(Figure D)

Hummer H2 2003-2007

1. Open center console and remove (4) 9/32" screws from console box and remove box. (Figure A)
2. Remove (4) Phillips screws from hinge on console door inside console and remove door. (Figure B)
3. Loosen (1) T-15 Torx on forward facing side of shift lever and pull up to remove. (Figure C)
4. Unclip cup holder/shifter trim assembly and remove. (Figure D)
5. Remove (6) Phillips screws from top of center console.
6. Remove (2) Phillips screws from inside pocket on back of center console, then unclip and remove.

Continued on next page

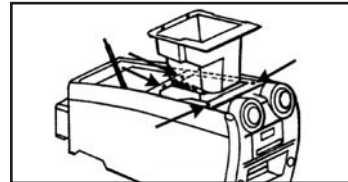

(Figure A)

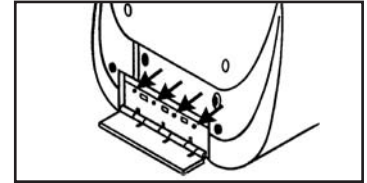

(Figure B)

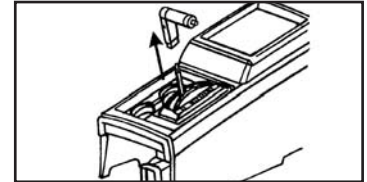

(Figure C)

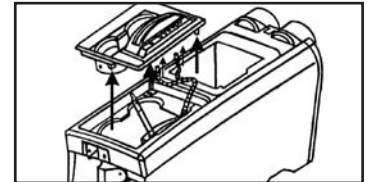

(Figure D)

Hummer H2 2003-2007

7. Remove (1) 10mm bolt to right of shift lever. (Figure E)
8. Remove (2) Phillips screws from under console box on drivers side and (2) Phillips screws from under console trimtop on passenger side. (Figure E)
9. Slide control assembly rearwards. (Figure F)
10. Remove (2) T-30 Torx bolts from top of rado/climate control trim and unclip and remove. (Figure G)
11. Remove (3) 9/32" screws that hold the radio in. (Figure G)

Continue to tab instructions

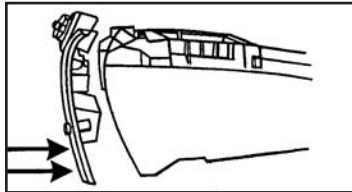

(Figure F)

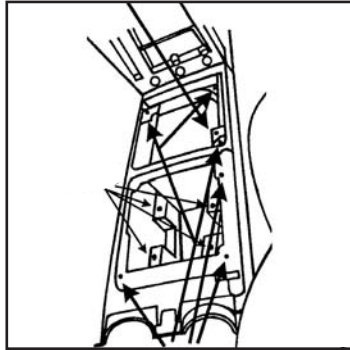

(Figure E)

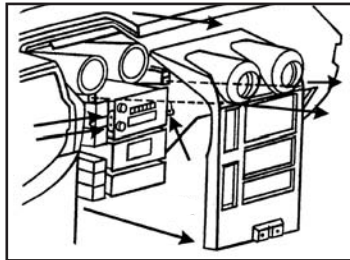

(Figure G)

Buick Rainier 2004-2007, GMC Envoy 2002-2009, Isuzu Ascender 2003-2008, Oldsmobile Bravada 2002-2004

1. Remove (4) Phillips screws, (2) from left and (2) from right of carpeted panel. (Figure A)
2. Slide carpeted panel down and backwards to reveal (2) Phillips screws and remove. (Figure B)
3. Unsnap radio bezel and unplug cigarette lighter and accessories. (Figure C)
4. Remove (3) screws and remove radio. (Figure C)

Continue to tab instructions

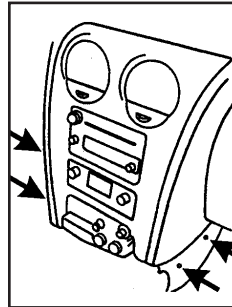

(Figure A)

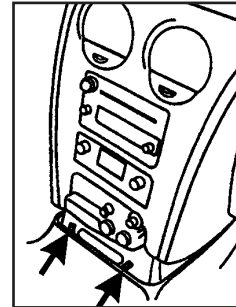

(Figure B)

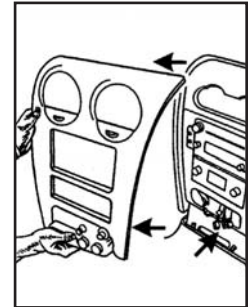

(Figure C)



Dash Disassembly 99-2003

Oldsmobile Achieva 1996-1998

1. Open the glove box, press inward on the walls of the glove box liner and remove the liner.
2. Remove (10) Torx-head screws from the glove box location.
3. Remove (2) 9/32" hex-head screws under the steering column.
4. Unclip the dash trim bezel. (Figure A)
5. Remove the screws securing the factory head unit and disconnect the wiring.

Continue to tab instructions

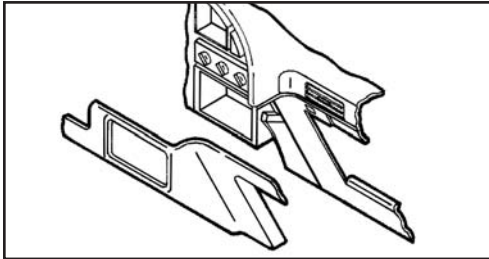

(Figure A)

Oldsmobile Alero 1999-2004

1. Remove shift knob by using a small screwdriver to remove U-clip from front of shifter and pull upward.
2. Unclip and remove shifter trim panel.
3. Unclip and remove radio and climate control panel by pulling from bottom. (Figure A)
4. Remove (3) 9/32" screws from radio and remove.

Continue to tab instructions

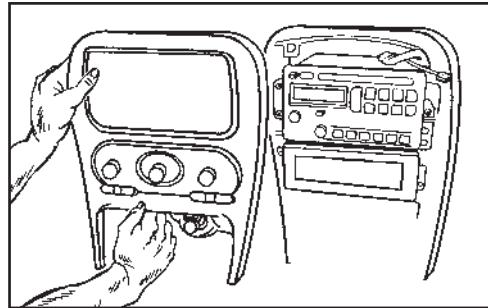

(Figure A)

Oldsmobile Aurora 1995-2003

1. Unclip the radio trim bezel and remove the bezel. (Figure A)
2. Remove (3) 9/32" screws securing the factory head unit and disconnect the wiring.

Continue to tab instructions

Note: For the Buick Le Sabre, Oldsmobile Aurora and the Pontiac Bonneville the (3) speed clips and screws provided with the kit will need to be installed into the sub dash where the screw holes line up on the kit.

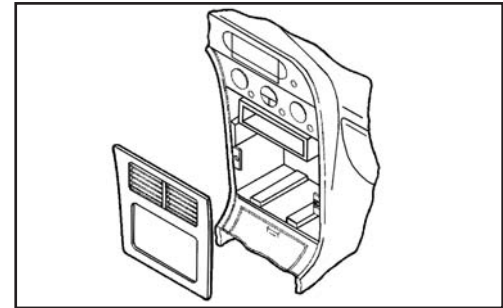

(Figure A)



Dash Disassembly 99-2003

Oldsmobile Cutlass 1997-1999, Oldsmobile Cutlass Supreme 1995-1997

1. Unclip the radio trim bezel and remove. (Figure A)
2. Remove (3) 7mm hex-head screws securing the factory head unit and disconnect the wiring.

Continue to tab instructions

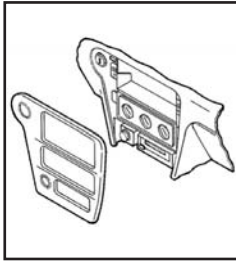

(Figure A)

Oldsmobile Eighty-Eight 1994-1999

1. Unclip the radio trim bezel and remove.
2. Remove (2) 9/32" hex-head screws securing the factory head unit and disconnect the wiring.

Continue to tab instructions

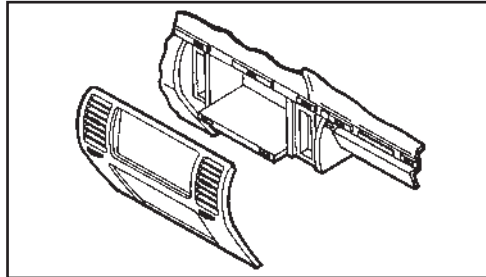

(Figure A)

Oldsmobile Ninety-Eight 1994-1996

1. Open the glove box and remove (2) hex-head screws securing the wood trim.
2. Unsnap the wood trim and remove.
3. Remove (2) hex-head screws below the radio trim bezel.
4. Lift up on the bezel and remove. (Figure A)
5. Remove (3) Phillips hex-head screws securing the factory head unit and disconnect the wiring.

Continue to tab instructions

Oldsmobile Intrigue 1998-2002

1. Open the center console storage compartment and remove (2) 9/32" hex-head screws exposed.
2. Remove the center console.
3. Unclip the radio trim bezel and remove. (Figure A)
4. Remove (2) 9/32" hex-head screws securing the factory head unit and disconnect the wiring.

Continue to tab instructions

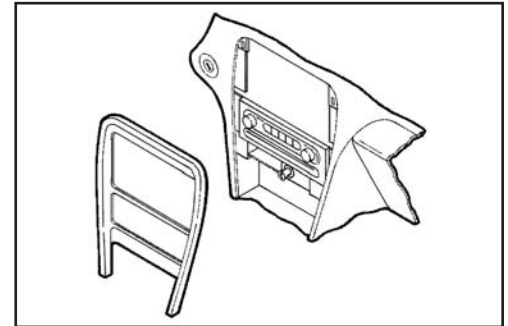

(Figure A)



Dash Disassembly 99-2003

Oldsmobile L55 1996-1999 Oldsmobile Regency 1997-1998

1. Open glove box and remove two-center trim bezels attached by screws. (Figure A)
2. Unsnap and remove radio trim bezel. (Figure A)
3. Remove (3) 9/32" hex-head screws and remove radio. (Figure B)

Continue to tab instructions

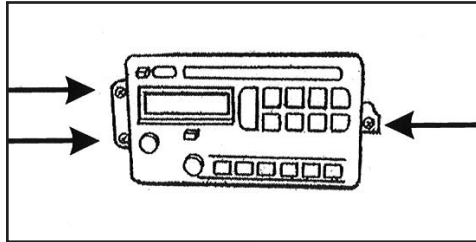

(Figure B)

Pontiac Aztec 2001-2005

1. Pull out cup holder inserts.
2. Remove (1) Phillips screw exposed inside bottom cup holder.
3. Unsnap and remove shifter trim with cup holders.
4. Remove (2) #15 Torx at bottom of radio/climate bezel.

Continue to tab instructions

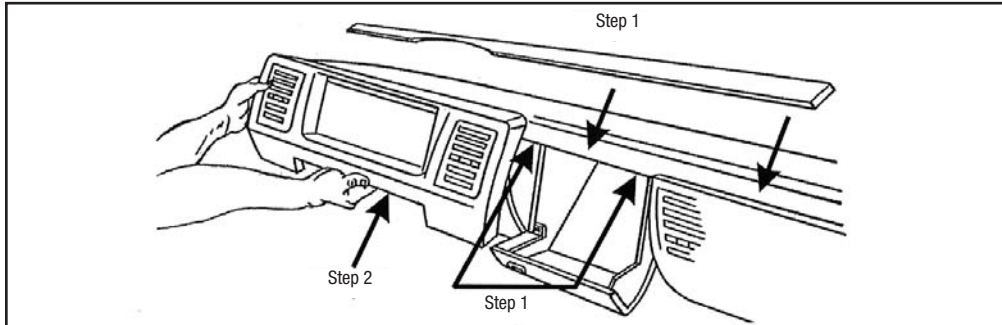

(Figure A)

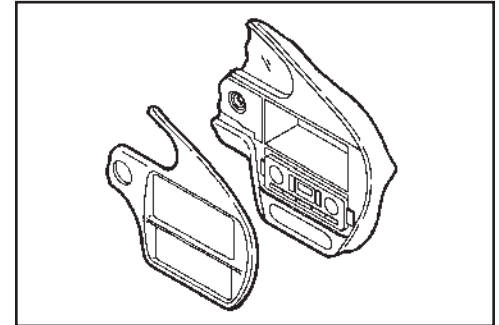



Dash Disassembly 99-2003

Pontiac Bonneville 2000-2005

1. Remove (2) Phillips screws from the instrument cluster. (Figure A)
2. Unclip the ignition trim and remove. (Figure B)
3. Unclip the climate control/radio trim bezel and remove.
4. Depress the spring clips on each side of the factory head unit and remove. (Figure C)

Continue to tab instructions

Note: For the Buick Le Sabre, Oldsmobile Aurora and the Pontiac Bonneville the (3) speed clips and screws provided with the kit will need to be installed into the sub dash where the screw holes line up on the kit.

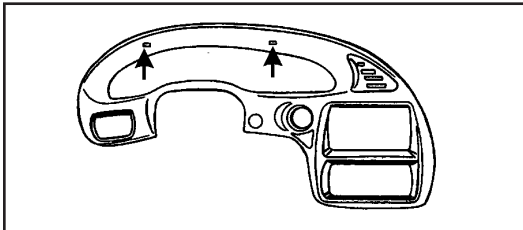

(Figure A)

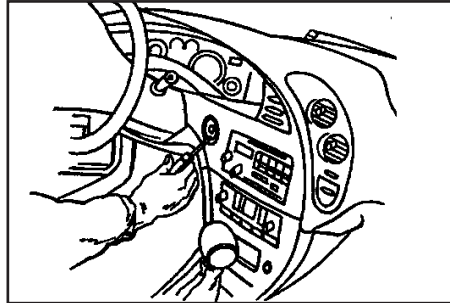

(Figure B)

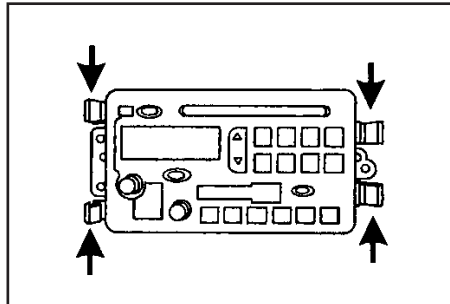

(Figure C)

Pontiac Grand Am 2001-2005

1. Unsnap and remove radio trim bezel. (Figure A)
2. Remove (3) 9/32" screws from radio brackets and remove radio. (Figure A)

Continue to tab instructions

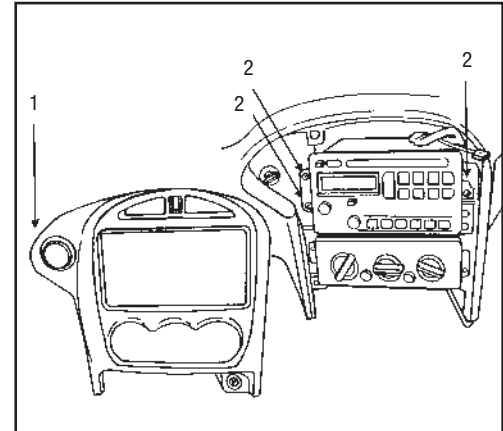

(Figure A)



Dash Disassembly 99-2003

Pontiac Sunfire 2000-2005

1. Open the glove box and remove (2) Phillips screws exposed on the right edge of the radio trim bezel. (Figure A)
2. Unclip the bezel and remove.
3. Remove (3) 9/32" hex-head screws securing the factory head unit and disconnect the wiring.

Continue to tab instructions

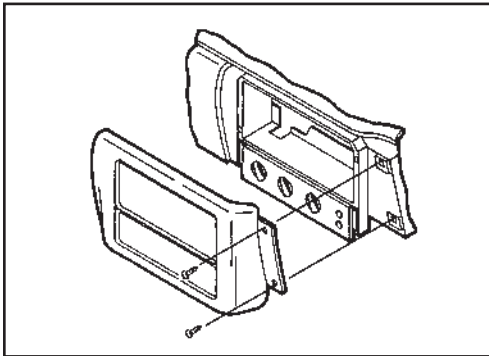

(Figure A)

Suzuki Aerio 2002

1. Unclip the dash trim bezel and remove. (Figure A)
2. Remove (4) Phillips screws securing the factory head unit and disconnect the wiring.

Continue to tab instructions

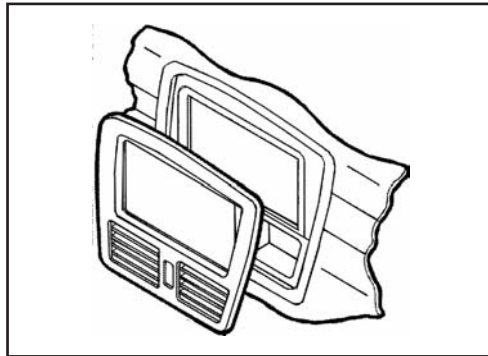

(Figure A)

Suzuki Esteem 1995-2003

1. Remove the climate control knobs.
2. Remove (1) Phillips screw located above the radio opening. (Figure A)
3. Unclip the radio trim bezel.
4. Remove (4) screws from the factory head unit, slide the unit out and disconnect the wiring.

Continue to tab instructions

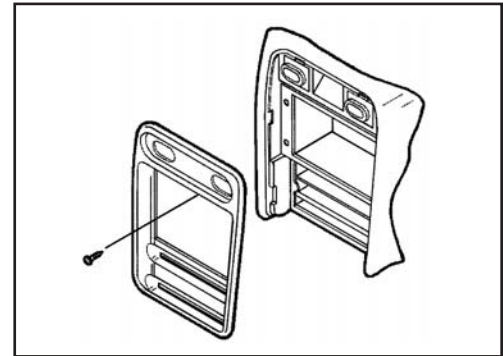

(Figure A)



Tab Instructions (Single DIN)

Kit Assembly (Single DIN)

Chevy/GM/Metro/Suzuki/Cadillac Fleetwood/Brougham

1. GM vehicles

Cut tabs highlighted on both sides of radio housing. (Figure A)

2. Chevy Tracker/Metro/Suzuki vehicles

Cut tabs highlighted on both sides of radio housing. (Figure B)

3. Cadillac Fleetwood/Brougham vehicles

Cut tabs highlighted on both sides of radio housing. (Figure C)

*Continue to kit assembly (Single DIN),
"DIN head unit provision"*

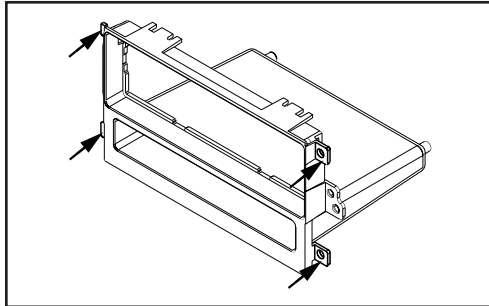

(Figure A)

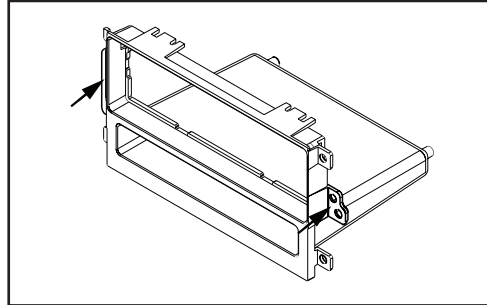

(Figure B)

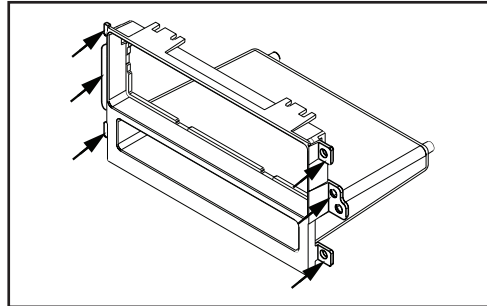

(Figure C)

All Vehicles DIN head unit provision

1. Locate the factory wiring harness in the dash. Metra recommends using the proper mating adapter from Metra or AXCESS. Re-connect the negative battery terminal and test the unit for proper operation.
2. Slide DIN cage into the housing and secure by bending metal locking tabs outward. (Figure A)
3. Slide radio into DIN cage. (Figure B)

Note: A snap-in DIN spacer has been provided for some applications where depth is an issue. Snap the spacer in the housing and slide DIN cage into the assembly and secure by bending metal locking tabs down. (Figure C)

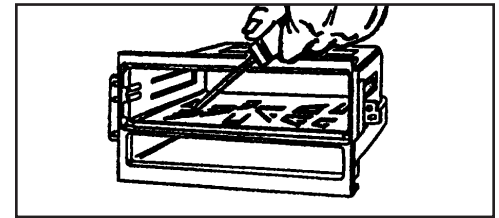

(Figure A)



All Vehicles DIN head unit provision

4. Reassemble dash in reverse order of disassembly.

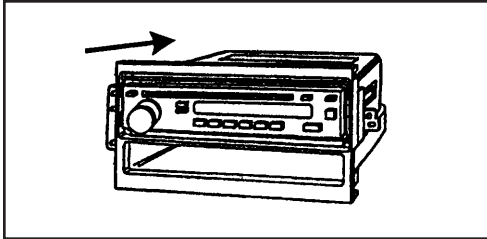

(Figure B)

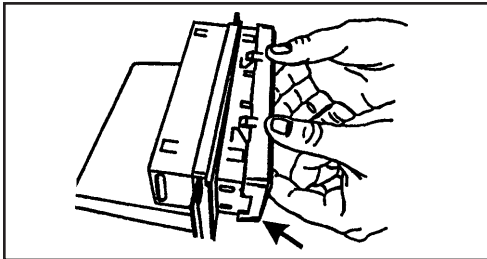

(Figure C)

Chevy/GM/Metro/Suzuki/Cadillac Fleetwood/Brougham

1. GM vehicles

Cut tabs highlighted on both sides of radio housing. (Figure A)

2. Chevy Tracker/Metro/Suzuki vehicles

Cut tabs highlighted on both sides of radio housing. (Figure B)

3. Cadillac Fleetwood/Brougham vehicles

Cut tabs highlighted on both sides of radio housing. (Figure C)

*Continue to kit assembly (Double DIN),
"Double DIN head unit provision"*

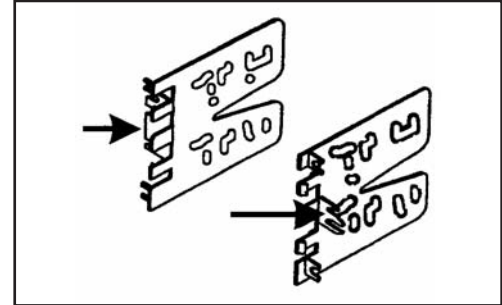

(Figure B)

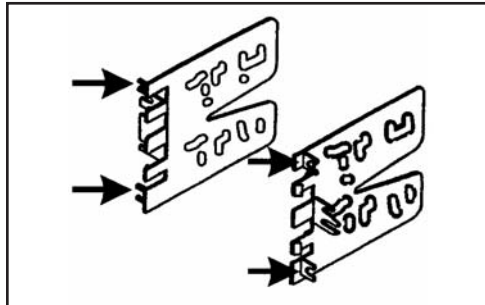

(Figure A)

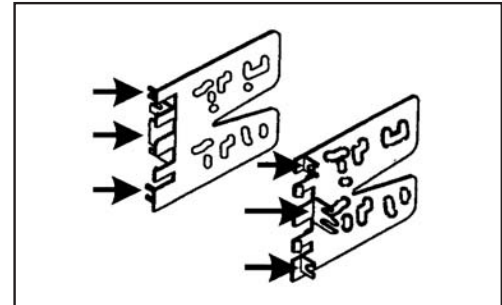

(Figure C)



Kit Assembly (Double DIN)

Kit Assembly

All Vehicles Double DIN head unit provision

1. Locate the factory wiring harness in the dash. Metra recommends using the proper mating adapter from Metra or AXCESS. Re-connect the negative battery terminal and test the unit for proper operation.
2. Remove the center bar from DDIN trim plate. (Figure A)
3. Attach the DDIN/stacked ISO brackets by aligning the holes and securing the unit to the brackets using the screws supplied with the units. (Figure B)
4. Snap the bracket & unit assembly to the DDIN trim plate. (Figure C)

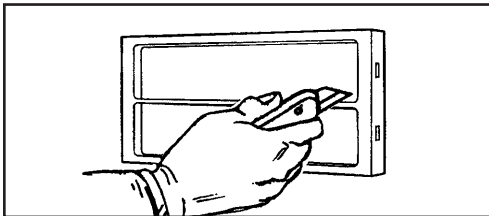

(Figure A)

5. Reassemble dash in reverse order of disassembly.

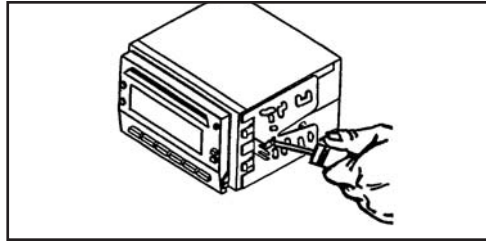

(Figure B)

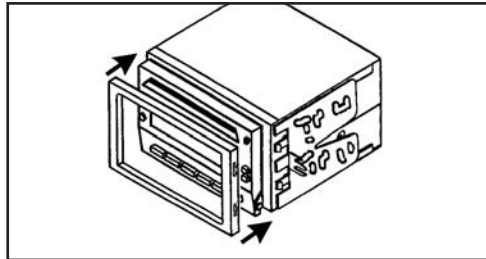

(Figure C)

All Vehicles Stacked ISO head unit provision

1. Locate the factory wiring harness in the dash. Metra recommends using the proper mating adapter from Metra or AXCESS. Re-connect the negative battery terminal and test the unit for proper operation.
2. Attach the DDIN/stacked ISO brackets by aligning the holes and securing the units to the brackets using the screws supplied with the units. (Figure A)
3. Snap the bracket & unit assembly to the DDIN trim plate. (Figure B)
4. Reassemble dash in reverse order of disassembly.



INSTALLATION INSTRUCTIONS FOR PART 99-2003



REV. 9/19/2013 INST-2003



KNOWLEDGE IS POWER

Enhance your installation and fabrication skills by enrolling in the most recognized and respected mobile electronics school in our industry. Log onto www.installerinstitute.com or call 800-354-6782 for more information and take steps toward a better tomorrow.

**Metra recommends MECP
certified technicians**

METRA. The World's best kits.™

1-800-221-0932

metraonline.com

© COPYRIGHT 2004-2011 METRA ELECTRONICS CORPORATION



INSTRUCCIONES DE INSTALACIÓN PARA LA PIEZA 99-2003

APLICACIONES

Lista de aplicaciones dentro

GM/Suzuki multi-kit 1990 y mas 99-2003/AT-555GM/AW-555GM

CARACTERÍSTICAS DEL KIT

- Provisión de radio DIN con bolsillo
- Provisión de radio doble DIN
- Provisión de radio ISO vertical



COMPONENTES DEL KIT

- A) Alojamiento del radio con bolsillo • B) Placa de terminación ISO • C) Placa de terminación DDIN
- D) Soportes ISO apilados DDIN • E) Espaciador DIN • F) Soportes para colocar a presión ISO • G) Pernos de cabeza de hongo • H) Tuercas de trinquete • I) (3) tornillos/(3) ganchos de conexión rápida

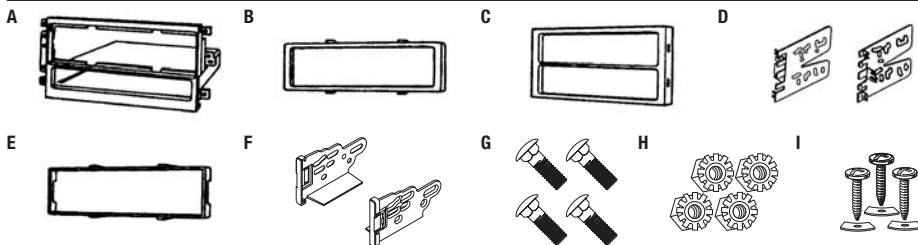

CABLEADO Y CONEXIONES DE ANTENA

Arnés de cableado: (se venden por separado)

- Visita www.metraonline.com para aplicaciones específicas

Adaptador de antena:

- 40-GM10 - Adaptador de antena GM 1988 y mas
- 40-CR10 - Adaptador de antena 2002 y mas

HERRAMIENTAS REQUERIDAS

- Herramientas de corte • Destornillador Phillips
- Llave de tubo

PRECAUCIÓN: Metra recomienda desconectar el terminal negativo de la batería antes de comenzar cualquier instalación. Todos los accesorios, interruptores y, especialmente, las luces indicadoras de airbag deben estar enchufados antes de volver a conectar la batería a comenzar el ciclo de ignición.

NOTA: Remítase a las instrucciones incluidas con el radio de postventa.



99-2003

Applications

Buick

Century	1997-2005
Le Sabre	1995-2005
Park Avenue	1995-2005
Rainier	2004-2007
Regal	1995-2004
Rendezvous	2002-2007
Riviera	1996-1999
Roadmaster	1995-1996
Skylark	1996-1998

Cadillac

Escalade ESU/EXT	2003-2006
Fleetwood/ Brougham	1990-1996

Chevrolet/Geo

Avalanche	2003-2006
Blazer (con DDIN)	2002-2005
Cavalier	2000-2005
Colorado	2004-2012
Express Van (tamaño completo)	2001-2007
Impala	2000-2005
Kodiak	2003-2009
Malibu	2001-2003
Malibu Classic	2004-2005
Metro (Geo incluido)	1995-2001
Monte Carlo	2000-2005
SSR	2003-2006

Chevrolet (seguido)

S-10 (con DDIN)	2002-2004
Silverado Classic	2003-2007
Suburban	2003-2006
Tahoe	2003-2006
Tracker (Geo incluido)	1992-2004
Trailblazer	2002-2009
Venture	2000-2005

GMC

Canyon	2004-2012
Envoy	2002-2009
Savana (tamaño completo)	2001-2007
Sierra Classic	2003-2007
Sonoma (con DDIN)	2002-2004
Top Kick	2005-2009
Yukon/Yukon Denali/XL	2003-2006

Hummer

H2	2003-2007
----------	-----------

Isuzu

Ascender	2003-2008
i280/i350	2006
i290/i370	2007-2008

Oldsmobile

Achieva	1996-1998
Alero	1999-2004
Aurora	1995-2003

Oldsmobile (seguido)

Bravada	1998-2001
Bravada	2002-2004
Cutlass	1997-1999
Cutlass Supreme	1995-1997
Eighty-Eight	1994-1999
Intrigue	1998-2002
LSS	1996-1999
Ninety-Eight	1994-1996
Regency	1997-1998
Silhouette	2000-2004

Pontiac

Aztec	2001-2005
Bonneville	2000-2005
Grand Am	2001-2005
Montana	2000-2005
Sunfire	2000-2005

Suzuki

Aerio	2002
Esteem	1995-2003
Grand Vitara	1999-2002
Sidekick	1992-1998
Swift	1995-2001
Vitara	1999-2004
XL-7	2001-2002

Indice

Desmontaje del tablero

Buick

- Century 1997-2005	4
- Le Sabre 1995-2005	4
- Park Avenue 1995-2005	4
- Rainier 2004-2007	12
- Regal 1995-2004	4
- Rendezvous 2002-2007	5
- Riviera 1996-1999	5
- Roadmaster 1995-1996	6
- Skylark 1996-1998	6

Cadillac

- Escalade ESU/EXT 2003-2006	6
- Fleetwood/Brougham 1990-1996	7
- Radio Bracket Disassembly (Fleetwood/Brougham)	7

Chevrolet

- Avalanche 2003-2006	6
- Blazer 2002-2005	8
- Cavalier 2000-2005	8
- Colorado 2004-2012	8
- Express Van (tamaño completo) 2001-2002	9
- Express Van (tamaño completo) 2003-2007	9
- Impala 2000-2005	10



Desmontaje del tablero 99-2003

Indice

Chevrolet (seguido)

- Kodiak 2003-2009	6
- Malibu 2001-2003	10
- Malibu Classic 2004-2005	10
- Metro (Geo incluido) 1995-2001	10
- Monte Carlo 2000-2005	11
- SSR 2003-2006	11
- S-10 (con DDIN) 2002-2004	11
- Silverado Classic 2003-2007	6
- Suburban 2003-2006	6
- Tahoe 2003-2006	6
- Tracker (Geo incluido) 1992-2004	12
- Trailblazer 2002-2009	12
- Venture 2000	12
- Venture 2001-2005	13

GMC

- Canyon 2004-2012	8
- Envoy 2002-2009	14
- Savana 2001-2002	9
- Savana 2003-2007	9
- Sierra Classic 2003-2007	6
- Sonoma (con DDIN) 2002-2004	8
- Top Kick 2005-2009	6
- Yukon/Yukon Denali/XL 2003-2006	6

Hummer

- H2 2003-2007	13-14
----------------------	-------

Isuzu

- Ascender 2003-2009	14
- i280/i350	8
- i290/i370	8

Oldsmobile

- Achieva 1996-1998	15
- Alero 1999-2004	15
- Aurora 1995-2003	15
- Bravada 1998-2001	8
- Bravada 2002-2004	14
- Cutlass 1997-1999	16
- Cutlass Supreme 1995-1997	16
- Eighty-Eight 1994-1999	16
- Intrigue 1998-2002	16
- LSS 1996-1999	17
- Ninety-Eight 1994-1996	16
- Regency 1997-1998	17
- Silhouette 2000	12
- Silhouette 2001-2004	13

Pontiac

- Aztec 2001-2005	17
- Bonneville 2000-2005	18
- Grand Am 2001-2005	18
- Montana 2000	12
- Montana 2001-2005	13
- Sunfire 2000-2005	19

Suzuki

- Aerio 2002	19
- Esteem 1995-2003	19
- Grand Vitara 1999-2002	12
- Sidekick 1992-1998	12
- Swift 1995-2001	10
- Vitara 1999-2004	12
- XL-7 2001-2002	12

Instrucciones para pestañas

- Todos los vehículos, DIN	20
- Todos los vehículos, doble DIN	21

Ensamble del kit

- Provisión de radio DIN con bolsillo.....	20-21
- Provisión de radio doble DIN	22
- Provisión de radio ISO vertical	22-23



Desmontaje del tablero 99-2003

Buick Century 1997-2005 Buick Regal 1995-2004

1. Quite la pieza de moldura de plástico a la izquierda de la guantera y (1) tornillo Phillips que queda a la vista.
2. Suelte a presión el borde superior del panel del protector de rodillas.
3. Quite (1) tornillo Phillips del panel.
4. Quite el conjunto del cenicero y los (2) tornillos Phillips de cada lado.
5. Desenganche todo el bisel de la moldura del tablero y quite.
6. Abra las puertas y suelte las tapas de los extremos de cada lado del tablero.
7. Suelte y quite el panel del radio/conjunto de instrumentos.
8. Quite los (3) tornillos para retirar el radio.
Continúe con las instrucciones para pestañas

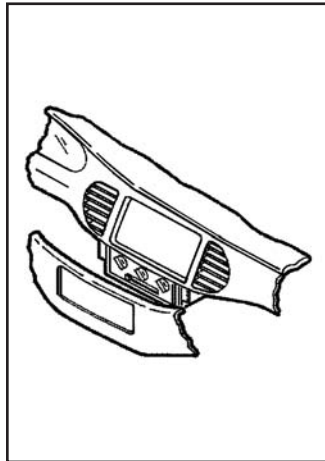

Buick Le Sabre 1995-1999 Buick Park Avenue 1995-1999

1. Suelte a presión el panel de la moldura del control de clima (de puerta a puerta) y quite los (4) tornillos Phillips expuestos.
2. Saque a presión las rejillas del aire acondicionado y quite (1) tornillo Phillips expuesto en cada cavidad de la rejilla.
3. Desenganche el bisel de la moldura del radio y quite.
4. Quite los tornillos que sujetan la unidad central de fábrica y desconecte el cableado.
Continúe con las instrucciones para pestañas

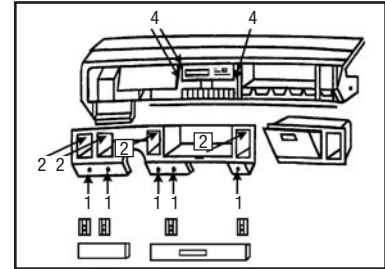

Buick Le Sabre 2000-2005 Buick Park Avenue 2000-2005

1. Abra la puerta del conductor y suelte a presión y quite la tapa del extremo del tablero.
 2. Quite los (2) tornillos Phillips de abajo de la tapa de la columna de dirección.
 3. Suelte a presión y quite la tapa de la columna de dirección.
 4. Suelte a presión y quite el panel de instrumentos.
 5. Quite los (2) tornillos de 9/32" y quite el radio.
Continúe con las instrucciones para pestañas
- Nota:** Para el Buick Le Sabre, Oldsmobile Aurora y el Pontiac Bonneville, los (3) ganchos de velocidad y tornillos suministrados con el kit deberán instalarse en el sub tablero donde los orificios se alinean con el kit.

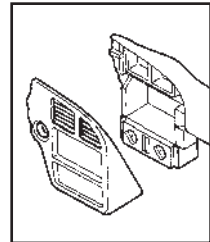



Desmontaje del tablero 99-2003

Buick Rendezvous 2002-2007

1. Abra la consola central y quite (2) tornillos al frente de la apertura de la consola. (Figura A)
2. Quite los revestimientos de los portavasos y de la cavidad de almacenamiento junto a los portavasos, luego quite los tornillos. Suelte y quite el panel. (Figura B)
3. Quite (2) tornillos de la parte inferior del bisel del radio/control de clima, desenganche y quite. (Figura C)
4. Quite los (3) tornillos de cabeza hexagonal de 9/32" para retirar el radio. (Figura D)

Continúe con las instrucciones para pestañas

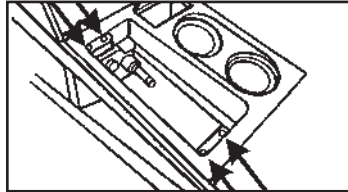

(Figura B)

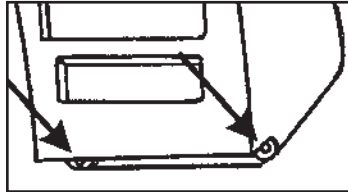

(Figura C)

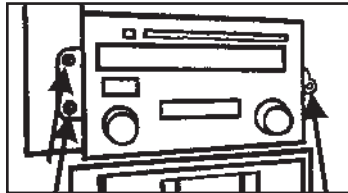

(Figura D)

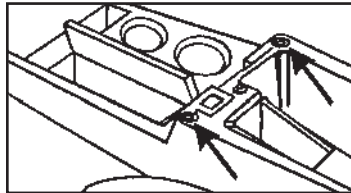

(Figura A)

Buick Riviera 1996-1999

1. Suelte a presión el panel del lado izquierdo, exponiendo (1) tornillo Phillips debajo del panel para retirar.
2. Quite (1) tornillo Phillips y suelte a presión el panel del lado derecho para exponer (1) tornillo Phillips debajo del panel y quite.
3. Suelte a presión la parte inferior del tablero que sobresale para soltar los (6) remaches de plástico y quite el panel.
4. Quite los (5) tornillos de cabeza hexagonal expuestos debajo de la parte que sobresale.
5. Suelte a presión el borde inferior del bisel de la moldura y luego, mientras sostiene la parte que sobresale, suelte y quite el bisel de la moldura, retirando cualquier arnés necesario.
6. Quite los (3) tornillos Phillips para retirar el control de clima.
7. Quite los (2) tornillos Phillips para retirar el soporte posterior y (3) tornillos de cabeza hexagonal de 9/32" para retirar el radio.

Continúe con las instrucciones para pestañas

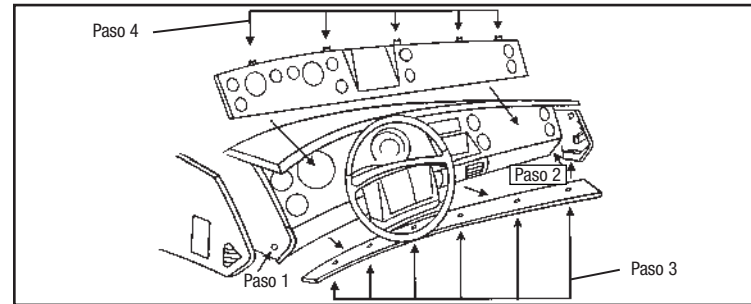



Desmontaje del tablero 99-2003

Buick Roadmaster 1995-1996

1. Desenganche los lados del panel del tablero y quite.
2. Desenganche el panel debajo de la columna de dirección y quite.
3. Quite los (2) tornillos de 7mm de arriba del conjunto de instrumentos.
4. Ponga el freno de mano, encienda el vehículo y mueva la palanca de velocidades al cambio más bajo. Incline el volante hacia abajo, luego suelte a presión todo el panel del conjunto de instrumentos/radio y quite.
5. Quite los (3) tornillos de 7mm para retirar el radio.
Continúe con las instrucciones para pestañas

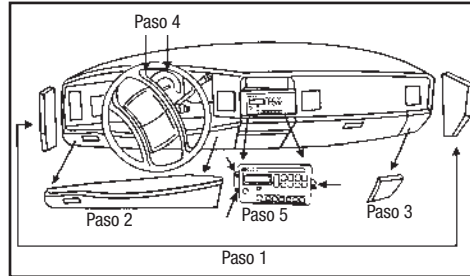

Buick Skylark 1996-1998

1. Quite los (6) tornillos de 9/32" del interior de la guantera.
2. Debajo de la guantera y del protector de rodillas del conductor, quite (2) paneles de plástico girando los (2) sujetadores 1/4 de vuelta por lado.
3. Quite los (4) tornillos de 9/32" que quedan a la vista ((2) por lado).
4. Suelte a presión el panel del lado del conductor al lado del pasajero.
5. Quite los (3) tornillos de 9/32" para quitar el radio.
Continúe con las instrucciones para pestañas

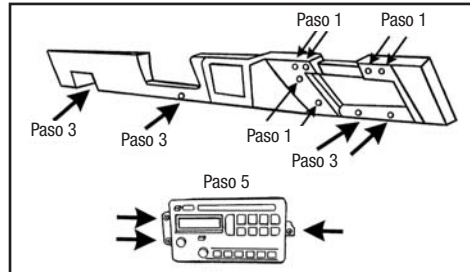

Cadillac Escalade ESU/ EXT 2003-2006, Chevrolet Avalanche 2003-2006/ Kodiak 2003-2009/ Silverado Classic 2003- 2007/Suburban 2003-2006/ Tahoe 2003-2006, GMC Sierra Classic 2003-2007/ Top Kick 2005-2009, GMC Yukon/Yukon Denali/XL 2003-2006

1. Suelte y quite el bisel del tablero. (Figura A)
2. Quite los (3) tornillos de 9/32" y quite el radio.
Continúe con las instrucciones para pestañas

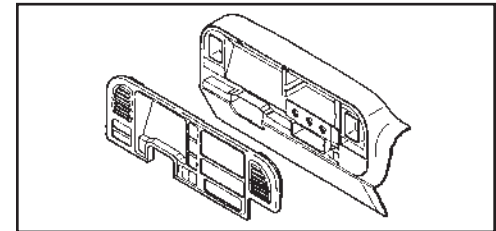

(Figura A)



Desmontaje del tablero 99-2003

Cadillac Fleetwood/Fleetwood Brougham 1990-1996

1. Suelte a presión cuidadosamente el panel de la moldura arriba del control del aire acondicionado. (Figura A)
2. Quite los (2) tornillos de 7mm en la parte superior del bisel del radio/aire acondicionado, luego desenganche el panel y quite. (Figura B and C)
3. Quite los (4) tornillos de 7mm que sostienen el radio, deslícelo hacia fuera, desconecte los arneses del radio y quite el radio. (Figura D)

Continuar con el "Radio soporte de desmontaje"
(lado derecho de la página, 7)

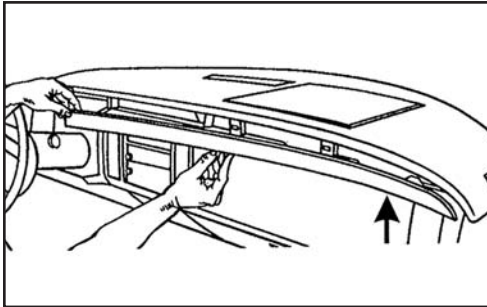

(Figura A)

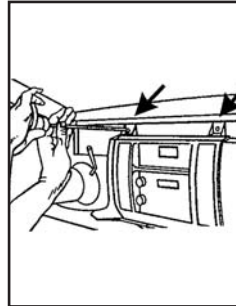

(Figura B)

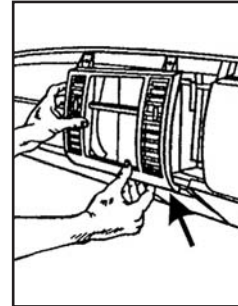

(Figura C)

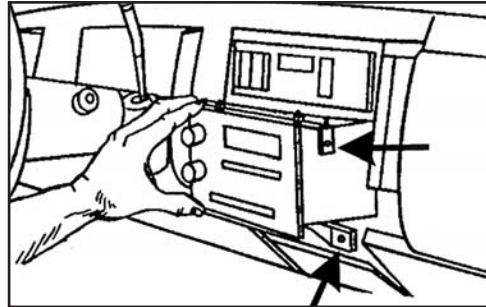

(Figura D)

Radio soporte de desmontaje

1. Quite las (4) tuercas de 10mm, (2) arriba del radio y (2) abajo del radio que sostienen los soportes de montaje. Reserve los soportes y las tuercas para el ensamble del kit. (Figura A)

Continúe con las instrucciones para pestañas

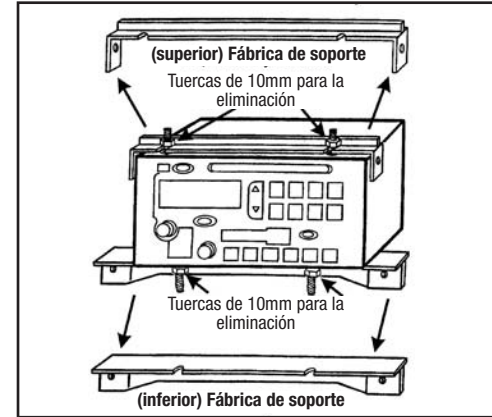

(Figura A)



Desmontaje del tablero 99-2003

Chevrolet Blazer 2002-2005/5-10 (con DDIN) 2002-2004, GMC Sonoma (con DDIN) 2002-2004, Oldsmobile Bravada 1998-2001

1. Quite los (2) tornillos de cabeza hexagonal de 9/32" del panel del protector de rodillas. (Figura A)
2. Jale hacia abajo el panel y quite los tornillos de cabeza hexagonal de 9/32" expuestos en la parte inferior del bisel de la moldura del tablero.
3. Quite (1) tornillo Phillips de arriba del conjunto de instrumentos.
4. Desenganche el bisel de la moldura del tablero y quite.
5. Quite los (2) tornillos de cabeza hexagonal de 9/32" que sujetan la unidad central de fábrica y desconecte el cableado.

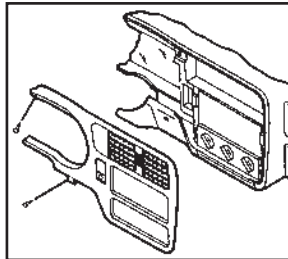

Continúe con las instrucciones para pestañas

(Figura A)

Chevrolet Cavalier 2000-2005

1. Abra la puerta del conductor y quite el panel de fusibles en el extremo del tablero.
2. Abra la puerta del pasajero y quite el panel del extremo del tablero.
3. Quite (1) tornillo Phillips expuesto de cada lado.
4. Quite los (3) tornillos de la parte superior del revestimiento de la guantera.
5. Quite los (2) tornillos de la esquina superior izquierda de la cavidad de la guantera.
6. Quite (1) tornillo Phillips del conducto del desempañador.
7. Quite el ducto y (1) tornillo Phillips expuesto.
8. Quite la almohadilla del tablero y (3) tornillos Phillips expuestos en la parte superior del bisel de la moldura del radio.

Continúe con las instrucciones para pestañas

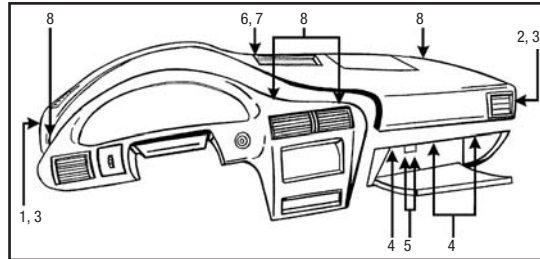

Chevrolet Colorado/GMC Canyon 2004-2012, Isuzu i280/i350 2006 i290/i370 2007-2008

1. Suelte y quite todo el panel que rodea el radio y los controles del aire acondicionado. (Figura A)
2. Quite los (3) tornillos de 9/32" que sujetan el radio para retirarlo. (Figura B)

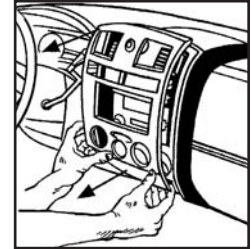

(Figura A)

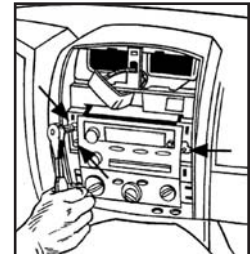

(Figura B)

Continúe con las instrucciones para pestañas



Desmontaje del tablero 99-2003

Chevrolet Express Van/GMC Savanna 2001-2002

1. Suelte a presión y quite el pequeño panel de la moldura debajo de la columna de dirección. (Figura A)
2. Suelte a presión el panel del radio/clima/instrumentos. (Figura B)
3. Mueva la palanca de velocidades a la posición del primer cambio.
4. Gire el panel hacia la izquierda para levantarlo sobre la columna de dirección y quite.
5. Quite los (3) tornillos de cabeza hexagonal de 9/32" para retirar el radio. (Figura C)

Continúe con las instrucciones para pestañas

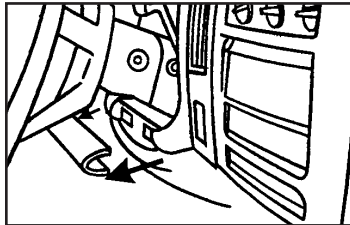

(Figura A)

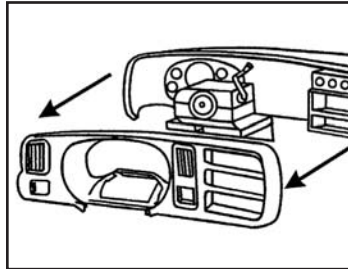

(Figura B)

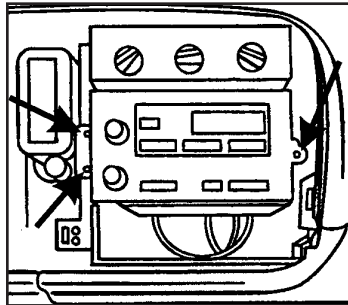

(Figura C)

Chevrolet Express Van 2003-2007 GMC Savanna 2003-2007

1. Quite los (2) pernos de 10mm de abajo del protector de rodillas debajo de la columna de dirección y quite el panel. (Figura A)
2. Quite los (2) pernos de 10mm del panel debajo del de la bolsa de aire del tablero del pasajero y quite el panel. (Figura B)
3. Quite las (2) tuercas de 10mm de la cavidad central interior entre los tomacorrientes. (Figura C)
4. Suelte a presión y quite el radio y el panel del conjunto de instrumentos (quizá no sea necesario retirar el radio y el panel del conjunto de instrumentos para obtener acceso al radio).
5. Quite los (3) pernos de 9/32" para quitar el radio. (Figura D)

Continúe con las instrucciones para pestañas

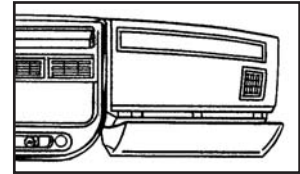

(Figura B)

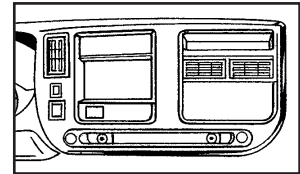

(Figura C)

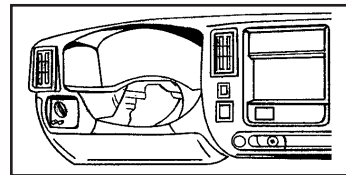

(Figura A)

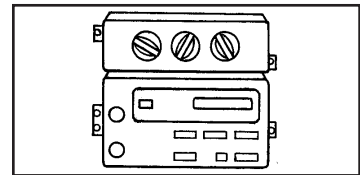

(Figura D)



Desmontaje del tablero 99-2003

Chevrolet Impala 2000-2005

1. Desenganche cada lado del bisel de la moldura del tablero (acceso a los fusibles) y quite (1) tornillo Phillips expuesto a cada lado.
2. Quite (2) tornillos Phillips de abajo del conjunto de instrumentos.
3. Desenganche el panel de la moldura sobre los pedales. (no es necesario retirar el panel, puede dejarse colgando).
4. Quite los (2) tornillos Phillips del panel para las rodillas.
5. Desenganche el panel para las rodillas y quite (1) tornillo Phillips expuesto en el lado derecho de la columna de dirección.
6. Desenganche y quite todo el bisel de la moldura del tablero.

Continúe con las instrucciones para pestañas

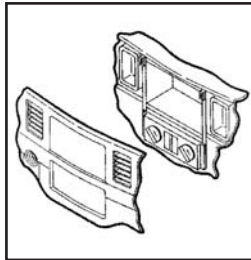

Chevrolet Malibu 2001-2003, Chevrolet Malibu Classic 2004

1. Suelte y quite el bisel del radio.
2. Quite los (3) pernos y quite el radio.

Continúe con las instrucciones para pestañas

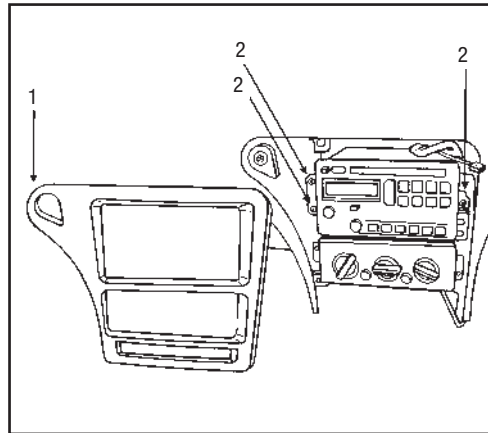

Chevrolet Metro/Suzuki Swift 1995-2001

1. Quite el cenicero y los (2) tornillos Phillips expuestos. (Figura A)
2. Quite los (2) tornillos Phillips de arriba de la apertura del radio. (Figura A)
3. Desenganche el bisel de la moldura del radio y desconecte el cableado del encendedor.
4. Quite los (2) tornillos que sujetan cada lado de la unidad central de fábrica y (1) tornillo del soporte trasero.
5. Deslice la unidad hacia afuera y desconecte el cableado.

Continúe con las instrucciones para pestañas

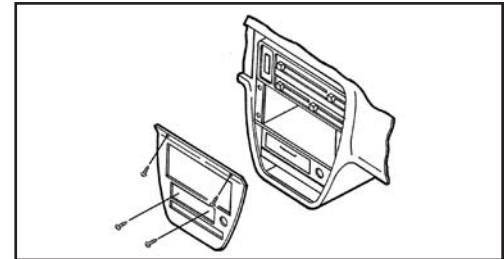

(Figura A)



Desmontaje del tablero 99-2003

Chevrolet Monte Carlo 2000-2005

1. Suelte el panel de la moldura de arriba de los pedales (*no es necesario quitar el panel, puede dejarse colgando*). (Figura A)
2. Quite los (2) tornillos de 9/32" del panel para las rodillas y desenganche el panel.
3. Suelte a presión la cubierta del panel de fusibles del lado del conductor y quite (1) tornillo de 9/32".
4. Abra la guantera y quite (1) tornillo de 9/32" de la esquina superior izquierda.
5. Quite los (3) tornillos de 9/32" que sujetan la unidad central de fábrica y desconecte el cableado.

Continúe con las instrucciones para pestañas

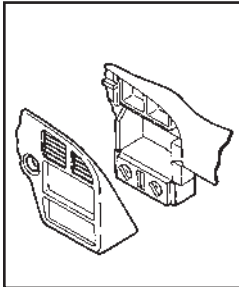

(Figura A)

Chevrolet SSR 2003-2006

1. Suelte y quite las (3) perillas de control del clima. (Figura A)
2. Suelte y quite el panel largo de moldura debajo del radio y de la bolsa de aire del pasajero. (Figura B)
3. Desenganche y quite el panel de moldura pequeño a la izquierda del volante. (Figura C)
4. Quite los (5) tornillos de 9/32" que sujetan el radio/panel de instrumentos y luego desenganche y quite el panel. (Figura D)
5. Quite los tornillos que sujetan la unidad central de fábrica y desconecte el cableado.

Continúe con las instrucciones para pestañas

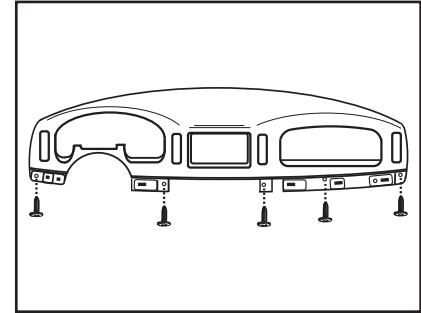

(Figura D)

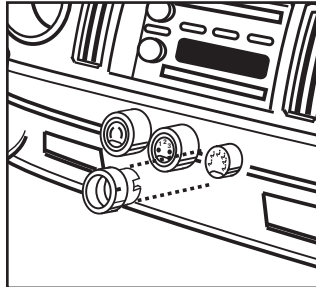

(Figura A)

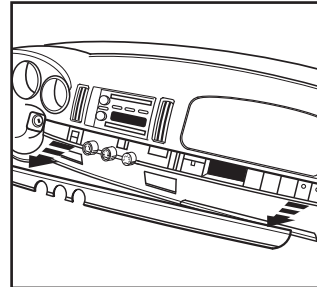

(Figura B)

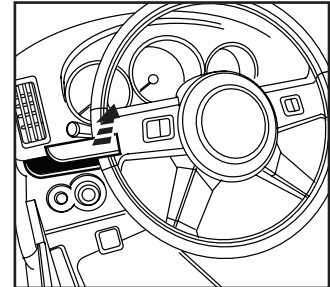

(Figura C)



Desmontaje del tablero 99-2003

Chevrolet Tracker *(Geo incluido)* **1992-2004, Suzuki Sidekick 1992-1998, Suzuki Vitara 1999-2004/Grand Vitara 1999-2002/XL-7 2001-2002**

1. Quite el encendedor y las perillas de control del clima.
2. Quite el cenicero y el (1) tornillo expuesto. (Figura A)
3. Jale el conjunto de control del clima y quite los (2) tornillos expuestos.
4. Desenganche el bisel de la moldura del radio.
5. Quite los (4) tornillos de la unidad central de fábrica, deslice la unidad hacia fuera y desconecte el cableado.

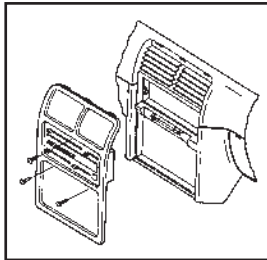

Continúe con las instrucciones para pestañas

(Figura A)

Chevrolet Trailblazer 2002-2009

1. Quite los (2) tornillos Phillips del interior del conjunto de instrumentos.
2. Quite (1) tornillo Phillips debajo de los controles del clima a la izquierda del tomacorriente.
3. Quite los (2) tornillos de cabeza hexagonal de 7mm debajo de la columna de dirección y baje el panel.

Quite los (3) tornillos Phillips de alrededor del volante.

4. Suelte y quite el radio (*tenga cuidado al jalar sobre el interruptor de las luces intermitentes*). Quite los (3) tornillos de cabeza hexagonal de 7mm para retirar el radio.

Continúe con las instrucciones para pestañas

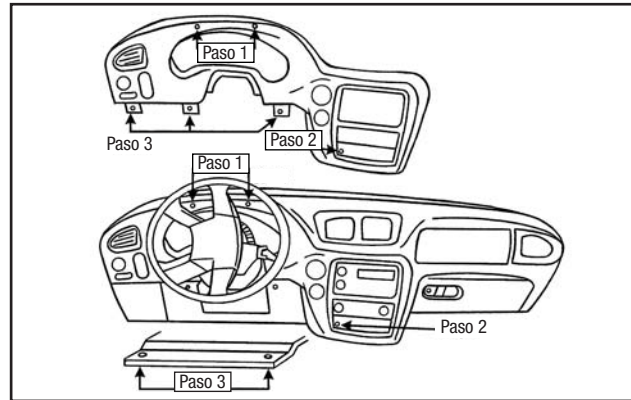

Chevrolet Venture/ Oldsmobile Silhouette/Pontiac Montana 2000 *(Excepto SV6)*

1. Quite el cenicero y (1) tornillo Phillips expuesto en la cavidad del cenicero.
2. Quite (1) tornillo Phillips del compartimiento del encendedor.
3. Quite los (2) tornillos Phillips que sujetan la unidad central de fábrica y desconecte el cableado.

Continúe con las instrucciones para pestañas

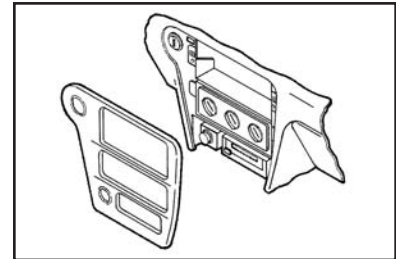



Desmontaje del tablero 99-2003

Chevrolet Venture 2001-2005 Oldsmobile Silhouette 2001-2004 Pontiac Montana 2001-2005

1. Abra los portavasos y quite los (2) tornillos Phillips de 7mm. (Figura A)
2. Suelte a presión y quite el conjunto de tomacorriente dual del compartimiento inferior de almacenamiento.
3. Abra la puerta inferior de almacenamiento y quite los (2) tornillos de 7mm que hay adentro.
4. Modelos con DVD - Quite el reproductor de DVD y quite los (2) tornillos de 7mm de atrás y los (2)

tornillos de 7mm cerca del piso.

5. Quite el compartimiento de almacenamiento inferior. (Figura B)
6. Quite los (2) tornillos de 7mm (orientados hacia arriba) de abajo del portavasos. (Figura C)
7. Quite los (3) tornillos de cabeza hexagonal de 7mm y quite el radio. (Figura D)

Continúe con las instrucciones para pestañas

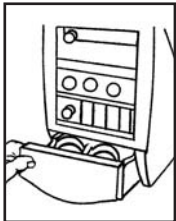

(Figura A)

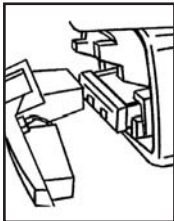

(Figura B)

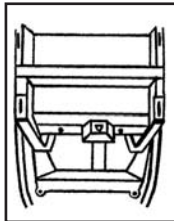

(Figura C)

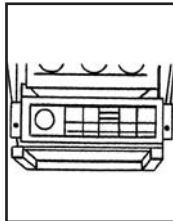

(Figura D)

Hummer H2 2003-2007

1. Abra la consola central y quite los (4) tornillos de 9/32" de la caja de la consola y quite la caja. (Figura A)
 2. Quite los (4) tornillos Phillips de la bisagra sobre la puerta de la consola al interior de la misma y quite la puerta. (Figura B)
 3. Afloje (1) tornillo Torx T-15 en el lado orientado hacia el frente de la palanca de velocidades y jale hacia arriba para retirar. (Figura C)
 4. Desenganche el ensamble de la moldura del portavasos/palanca de velocidades y quite. (Figura D)
 5. Quite los (6) tornillos Phillips de la parte superior de la consola central.
 6. Quite los (2) tornillos Phillips de la cavidad interior en la parte posterior de la consola central, luego desenganche y quite.
- Continúa en la página*

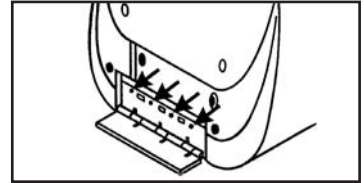

(Figura B)

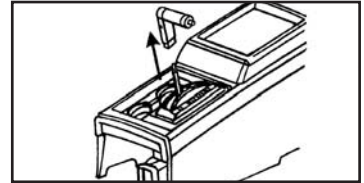

(Figura C)



(Figura A)

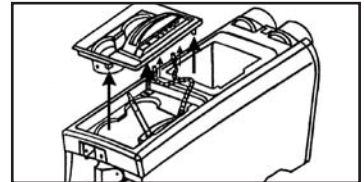

(Figura D)

Hummer H2 2003-2007

7. Quite (1) perno de 10mm a la derecha de la palanca de velocidades. (Figura A)
8. Quite los (2) tornillos Phillips debajo de la caja de la consola del lado del conductor y (2) tornillos Phillips debajo de la parte superior de la moldura de la consola en el lado del pasajero. (Figura A)
9. Deslice el ensamble del control hacia atrás. (Figura B)
10. Quite los (2) pernos Torx T-30 de la parte superior de la moldura del radio/control de clima y desenganche y quite. (Figura C)
11. Quite los (3) tornillos de 9/32" que sostienen el radio dentro. (Figura C)

Continúe con las instrucciones para pestañas

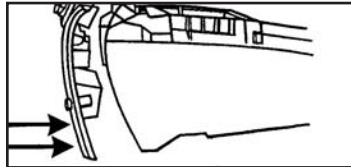

(Figura F)

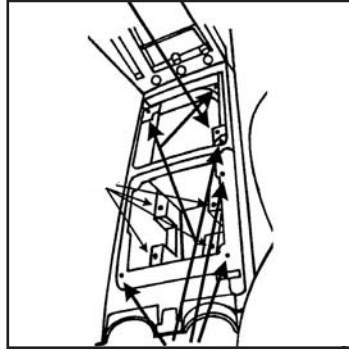

(Figura E)

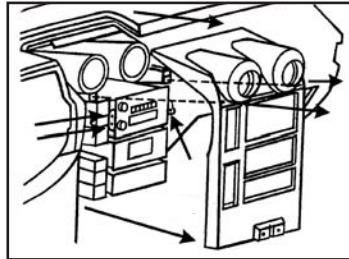

(Figura G)

Buick Rainier 2004-2007, GMC Envoy 2002-2009, Isuzu Ascender 2003-2008, Oldsmobile Bravada 2002-2004

1. Quite los (4) tornillos Phillips, (2) de la izquierda y (2) de la derecha del panel alfombrado. (Figura A)
2. Deslice el panel alfombrado hacia abajo y hacia atrás para revelar los (2) tornillos Phillips y quite. (Figura B)
3. Suelte a presión el bisel del radio y desconecte el encendedor y los accesorios. (Figura C)
4. Quite los (3) tornillos y quite el radio. (Figura C)

Continúe con las instrucciones para pestañas

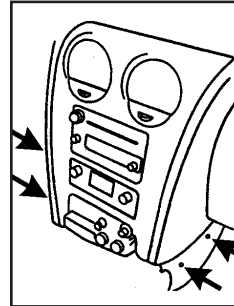

(Figura A)

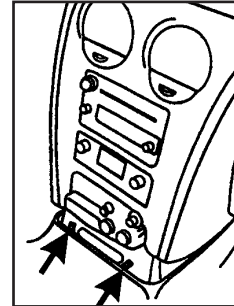

(Figura B)

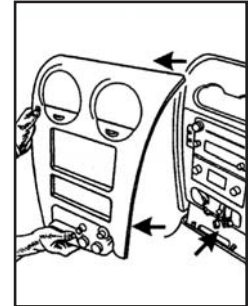

(Figura C)



Desmontaje del tablero 99-2003

Oldsmobile Achieva 1996-1998

1. Abra la guantera, presione hacia dentro las paredes del revestimiento de la guantera y quite el revestimiento.
2. Quite los (10) tornillos de cabeza Torx de la guantera.
3. Quite los (2) tornillos de cabeza hexagonal de 9/32" debajo de la columna de dirección.
4. Desenganche el bisel de la moldura del tablero. (Figura A)
5. Quite los tornillos que sujetan la unidad central de fábrica y desconecte el cableado.

Continúe con las instrucciones para pestañas

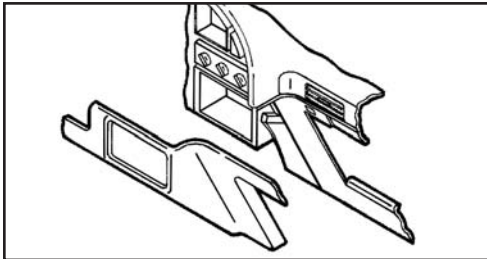

(Figura A)

Oldsmobile Alero 1999-2004

1. Quite la perilla de la palanca de velocidades con un pequeño destornillador para retirar el gancho en U de la parte frontal de la palanca de velocidades y jale hacia arriba.
2. Suelte y quite el panel de moldura de la palanca de velocidades.
3. Desenganche y quite el panel del radio y el control del clima jalando desde abajo. (Figura A)
4. Quite los (3) tornillos de 9/32" del radio y quítelo.

Continúe con las instrucciones para pestañas

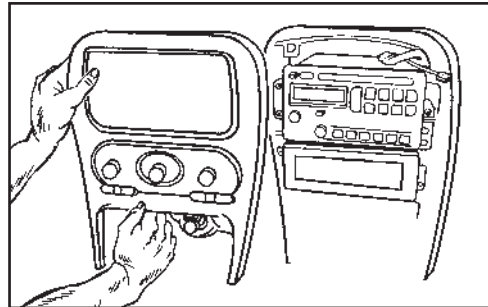

(Figura A)

Oldsmobile Aurora 1995-2003

1. Desenganche el bisel de la moldura del radio y quite el bisel. (Figura A)
2. Quite los (3) tornillos de 9/32" que sujetan la unidad central de fábrica y desconecte el cableado.

Continúe con las instrucciones para pestañas

Nota: Para el Buick Le Sabre, Oldsmobile Aurora y el Pontiac Bonneville, los (3) ganchos de velocidad y tornillos suministrados con el kit deberán instalarse en el sub tablero donde los orificios se alinean con el kit.

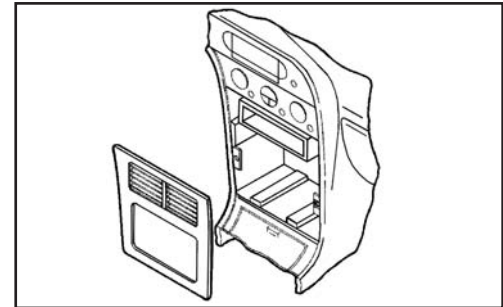

(Figura A)



Desmontaje del tablero 99-2003

Oldsmobile Cutlass 1997-1999, Oldsmobile Cutlass Supreme 1995-1997

1. Desenganche el bisel de la moldura del radio y quite. (Figura A)
2. Quite los (3) tornillos de cabeza hexagonal de 7mm que sujetan la unidad central de fábrica y desconecte el cableado.

Continúe con las instrucciones para pestañas

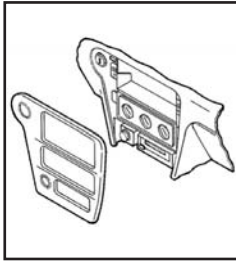

(Figura A)

Oldsmobile Eighty-Eight 1994-1999

1. Desenganche el bisel de la moldura del radio y quite.
2. Quite los (2) tornillos de cabeza hexagonal de 9/32" que sujetan la unidad central de fábrica y desconecte el cableado.

Continúe con las instrucciones para pestañas

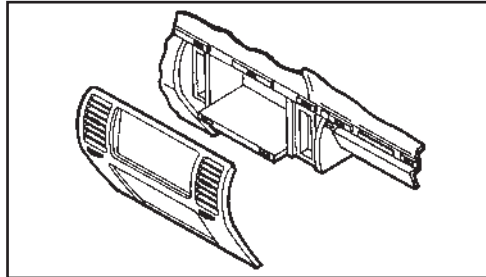

(Figura A)

Oldsmobile Ninety-Eight 1994-1996

1. Abra la guantera y quite los (2) tornillos de cabeza hexagonal que sujetan la moldura de madera.
2. Suelte a presión la moldura de madera y quite.
3. Quite los (2) tornillos de cabeza hexagonal debajo del bisel de la moldura del radio.
4. Levante el bisel y retírelo. (Figura A)
5. Quite los (3) tornillos Phillips de cabeza hexagonal que sujetan la unidad central de fábrica y desconecte el cableado.

Continúe con las instrucciones para pestañas

Oldsmobile Intrigue 1998-2002

1. Abra el compartimiento de almacenamiento de la consola central y quite los (2) tornillos de cabeza hexagonal de 9/32" expuestos.
2. Quite la consola central.
3. Desenganche el bisel de la moldura del radio y quite. (Figura A)
4. Quite los (2) tornillos de cabeza hexagonal de 9/32" que sujetan la unidad central de fábrica y desconecte el cableado.

Continúe con las instrucciones para pestañas

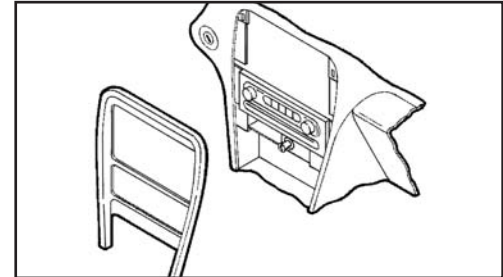

(Figura A)



Desmontaje del tablero 99-2003

Oldsmobile L55 1996-1999 Oldsmobile Regency 1997-1998

1. Abra la guantera y quite dos biseles de moldura centrales unidos con tornillos. (Figura A)
2. Suelte y quite el bisel de la moldura del radio. (Figura A)
3. Quite los (3) tornillos de cabeza hexagonal de 9/32" y quite el radio. (Figura B)

Continúe con las instrucciones para pestañas

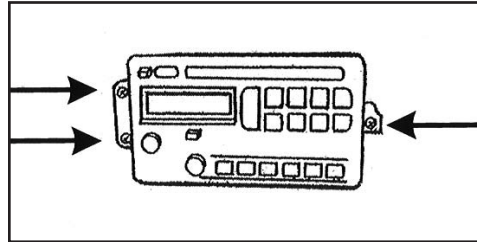

(Figura B)

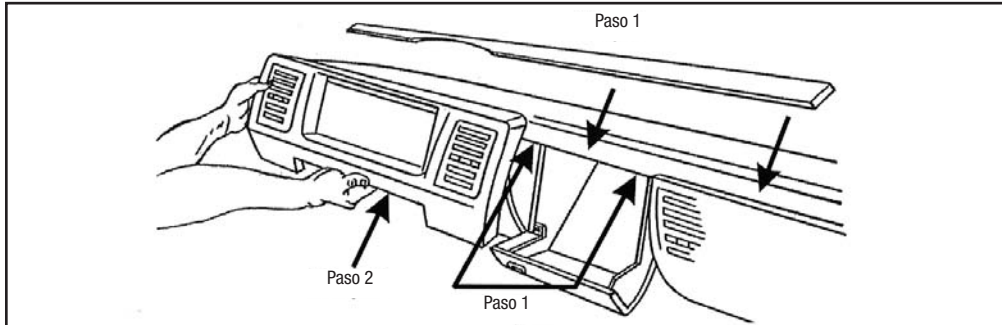

(Figura A)

Pontiac Aztec 2001-2005

1. Jale y saque los insertos de los portavasos.
2. Quite (1) tornillo Phillips expuesto del interior del portavasos.
3. Suelte a presión y quite la moldura de la palanca de velocidades con los portavasos.
4. Quite los (2) tornillos Torx #15 de la parte inferior del bisel del radio/clima.

Continúe con las instrucciones para pestañas

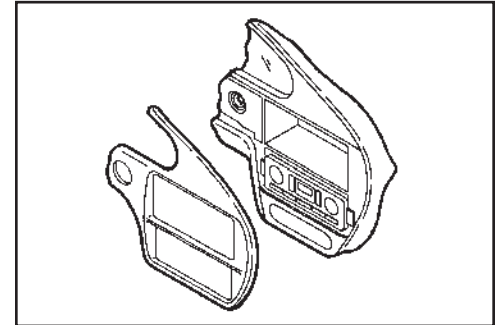



Desmontaje del tablero 99-2003

Pontiac Bonneville 2000-2005

1. Quite los (2) tornillos Phillips del conjunto de instrumentos. (Figura A)
2. Desenganche la moldura de la ignición y quite. (Figura B)
3. Desenganche el bisel del control de clima/moldura del radio y quite.
4. Apriete los ganchos de resorte a cada lado de la unidad central de fábrica y quite. (Figura C)

Continúe con las instrucciones para pestañas

Nota: Para el Buick Le Sabre, Oldsmobile Aurora y el Pontiac Bonneville, los (3) ganchos de velocidad y tornillos suministrados con el kit deberán instalarse en el sub tablero donde los orificios se alinean con el kit.

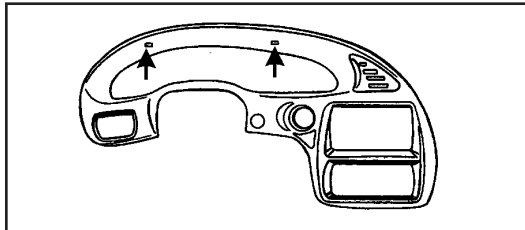

(Figura A)

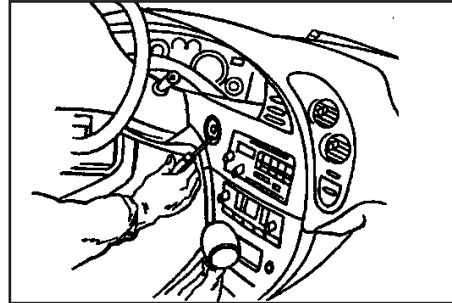

(Figura B)

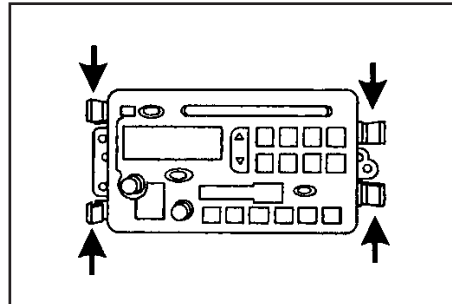

(Figura C)

Pontiac Grand Am 2001-2005

1. Suelte y quite el bisel de la moldura del radio.
2. Quite los (3) tornillos de 9/32" de los soportes del radio y quite el radio. (Figura A)

Continúe con las instrucciones para pestañas

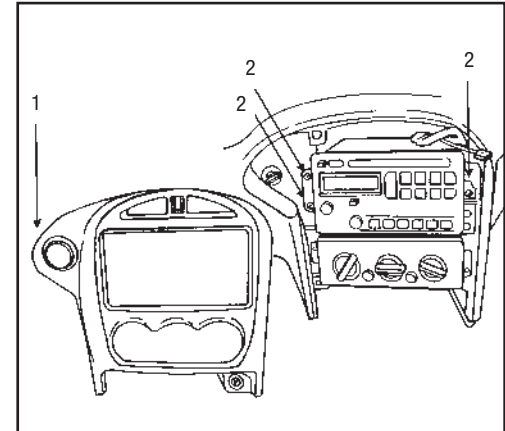

(Figura A)



Desmontaje del tablero 99-2003

Pontiac Sunfire 2000-2005

1. Abra la guantera y quite (2) tornillos Phillips expuestos en el borde superior derecho del bisel de la moldura del radio. (Figura A)
2. Desenganche el bisel y quite.
3. Quite los (3) tornillos de cabeza hexagonal de 9/32" que sujetan la unidad central de fábrica y desconecte el cableado.

Continúe con las instrucciones para pestañas

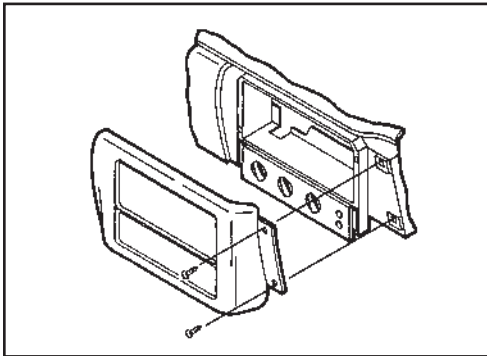

(Figura A)

Suzuki Aerio 2002

1. Desenganche el bisel de la moldura del tablero y quite. (Figura A)
2. Quite los (4) tornillos Phillips que sujetan la unidad central de fábrica y desconecte el cableado.

Continúe con las instrucciones para pestañas

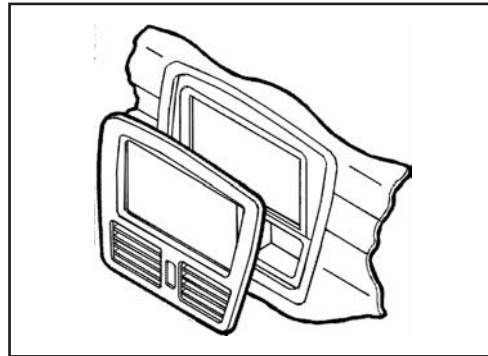

(Figura A)

Suzuki Esteem 1995-2003

1. Quite las perillas del control de clima.
2. Quite (1) tornillo Phillips localizado arriba de la apertura del radio. (Figura A)
3. Desenganche el bisel de la moldura del radio.
4. Quite los (4) tornillos de la unidad central de fábrica, deslice la unidad hacia fuera y desconecte el cableado.

Continúe con las instrucciones para pestañas

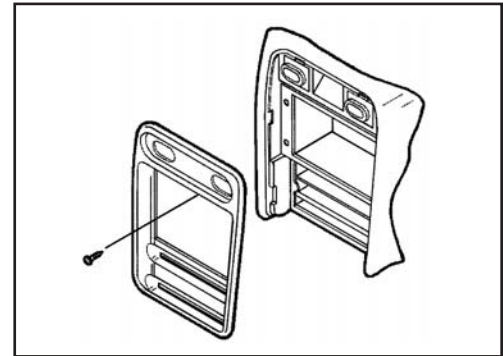

(Figura A)



Instrucciones para pestañas (DIN)

Ensamble del kit (DIN)

Chevy/GM/Metro/Suzuki/Cadillac Fleetwood/Brougham

1. GM vehículos

Cortar las pestañas destacadas en ambos lados de la vivienda radio. (Figura A)

2. Chevy Tracker/Metro/Suzuki vehículos

Cortar las pestañas destacadas en ambos lados de la vivienda radio. (Figura B)

3. Cadillac Fleetwood/Brougham vehículos

Cortar las pestañas destacadas en ambos lados de la vivienda radio. (Figura C)

Continuará al ensamble del kit (DIN),
"Provisión de radio DIN"

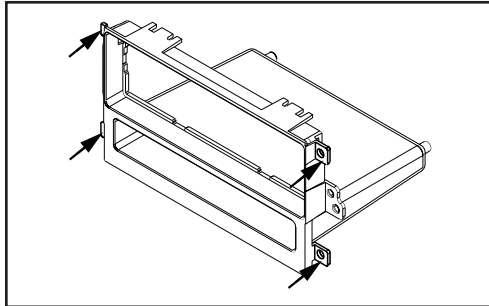

(Figura A)

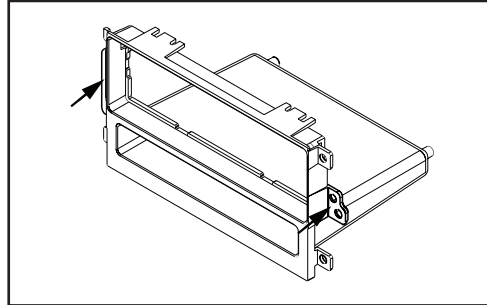

(Figura B)

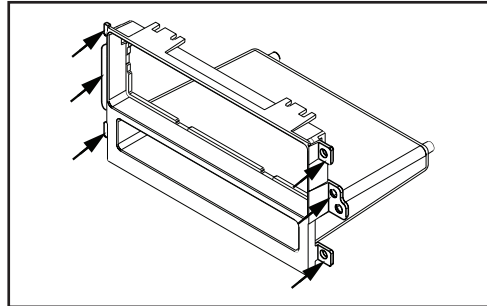

(Figura C)

Todos los vehículos Provisión de radio DIN

1. Ubique el arnés del cableado de fábrica en el tablero. Metra recomienda usar el adaptador de acoplamiento adecuado de Metra o AXCESS. Vuelva a conectar el terminal negativo de la batería y pruebe la unidad para verificar que funcione correctamente.
2. Deslice la rejilla DIN en la carcasa y sujétela doblando hacia afuera las pestañas de bloqueo de metal. (Figura A)
3. Deslice el radio para introducirlo en la rejilla DIN. (Figura B)

Nota: Se ha suministrado un espaciador DIN a presión para algunas aplicaciones en las que la profundidad es un problema. Coloque el espaciador en la carcasa y deslice la jaula DIN

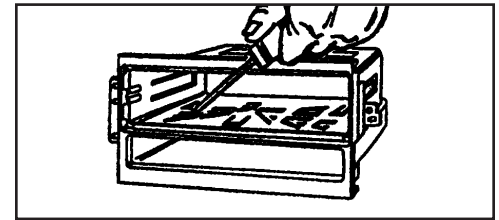

(Figura A)



Todos los vehículos Provisión de radio DIN

en el ensamble y sujétela doblando hacia abajo las pestañas de metal. (Figura C)

4. Vuelva a montar el tablero en forma inversa al desmontaje.

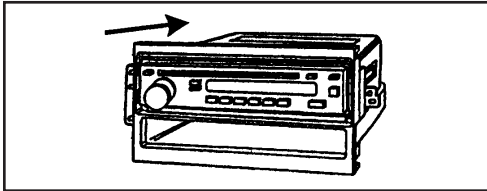

(Figura B)

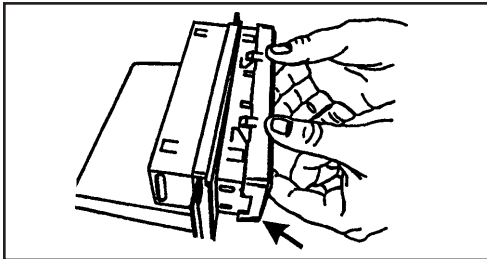

(Figura C)

Chevy/GM/Metro/Suzuki/Cadillac Fleetwood/Brougham

1. GM vehículos

Cortar las pestañas destacadas en ambos lados de la vivienda radio. (Figura A)

2. Chevy Tracker/Metro/Suzuki vehículos

Cortar las pestañas destacadas en ambos lados de la vivienda radio. (Figura B)

3. Cadillac Fleetwood/Brougham vehículos

Cortar las pestañas destacadas en ambos lados de la vivienda radio. (Figura C)

Continuará al ensamble del kit (Doble DIN),
"Provisión de radio doble DIN"

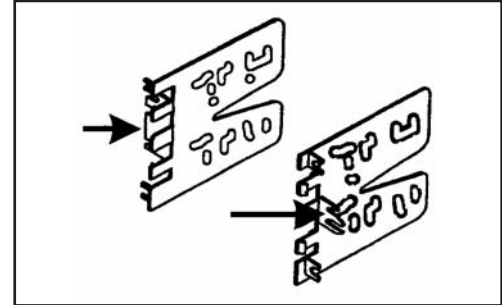

(Figura B)

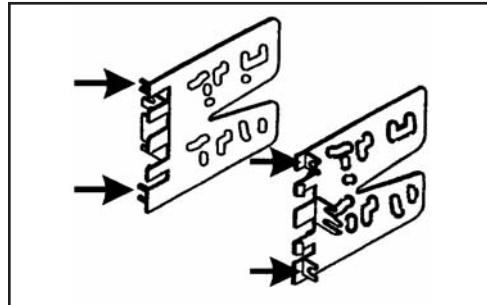

(Figura A)

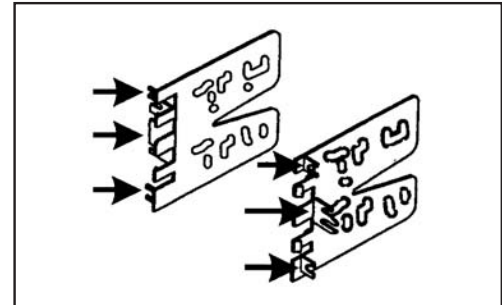

(Figura C)



Ensamble del kit (Doble DIN)

Todos los vehículos Provisión de radio doble DIN

1. Ubique el arnés del cableado de fábrica en el tablero. Metra recomienda usar el adaptador de acoplamiento adecuado de Metra o AXCESS. Vuelva a conectar el terminal negativo de la batería y pruebe la unidad para verificar que funcione correctamente.
2. Quite la barra central de la placa de la moldura DDIN. (Figura A)
3. Coloque los soportes ISO DDIN/verticales alineando los orificios y sujetando la unidad a los soportes con los tornillos suministrados con la unidad. (Figura B)
4. Coloque a presión y ensamble la unidad en la placa de la moldura DDIN. (Figura C)

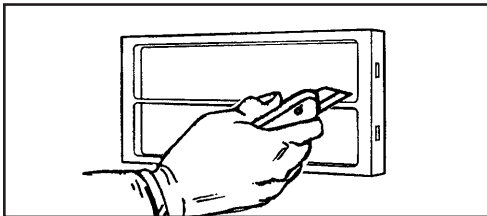

(Figura A)

5. Vuelva a montar el tablero en forma inversa al desmontaje.

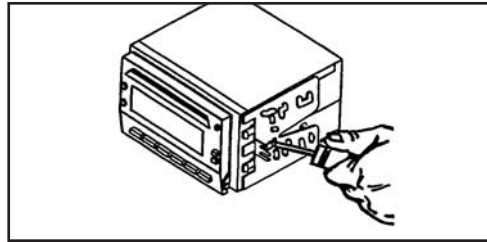

(Figura B)

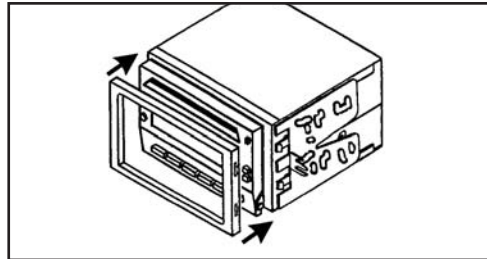

(Figura C)

Ensamble del kit

Todos los vehículos Provisión de radio ISO verticales

1. Ubique el arnés del cableado de fábrica en el tablero. Metra recomienda usar el adaptador de acoplamiento adecuado de Metra o AXCESS. Vuelva a conectar el terminal negativo de la batería y pruebe la unidad para verificar que funcione correctamente.
2. Coloque los soportes ISO DDIN/verticales alineando los orificios y sujetando las unidades a los soportes con los tornillos suministrados con las unidades. (Figura A)
3. Coloque a presión y ensamble la unidad en la placa de la moldura DDIN. (Figura B)
4. Vuelva a montar el tablero en forma inversa al desmontaje.



INSTRUCCIONES DE INSTALACIÓN PARA LA PIEZA 99-2003



REV. 9/19/2013 INST-2003



EL CONOCIMIENTO ES PODER
Mejore sus habilidades de instalación y fabricación inscribiéndose en la escuela de dispositivos electrónicos móviles más reconocida y respetada de nuestra industria. Regístrese en www.installerinstitute.com o llame al 800-354-6782 para obtener más información y avance hacia un futuro mejor.



Metra recomienda técnicos con certificación del Programa de Certificación en Electrónica Móvil (Mobile Electronics Certification Program, MECP).