



INSTALLATION INSTRUCTIONS FOR PART 95-7801

APPLICATIONS

See application list inside

Acura/Honda/Isuzu 1990-2006 95-7801

KIT FEATURES

- Double DIN radio provision
- Stacked ISO radio provision



KIT COMPONENTS

- A) Double DIN trim plate
- A) Radio housing
- B) Rear support tray
- C) ISO brackets
- D) Mounting bracket (Acura Legend)
- E) (2) #8 x 1/2" Phillips pan head screws
- F) (6) #6 x 1/4" Phillips flat head screws

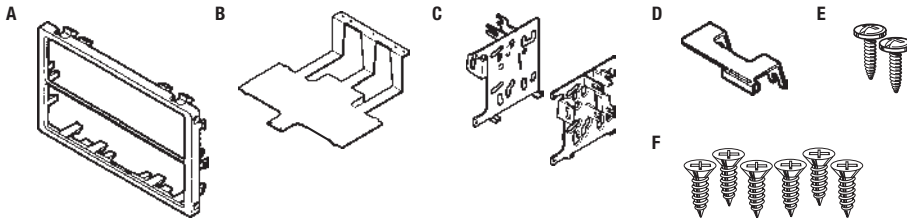

WIRING & ANTENNA CONNECTIONS (sold separately)

Wiring Harness:

- 70-1720 - Honda/Acura harness 1986-1998
- 70-1721 - Honda/Acura harness 1998-up
- 70-1724 - Accord amp Interface 1993-1994

Antenna Adapter:

- Not required

TOOLS REQUIRED

- Phillips screwdriver
- Cutting tool

CAUTION: Metra recommends disconnecting the negative battery terminal before beginning any installation. All accessories, switches, and especially air bag indicator lights must be plugged in before reconnecting the battery or cycling the ignition.

NOTE: Refer to the instructions included with the aftermarket radio.

Applications

Acura

CL.....	1997-1999
Integra.....	1990-1993
Integra.....	1994-2001
Legend.....	1990-1995
TL.....	1996-1998
Vigor.....	1992-1994

Honda

Accord.....	1990-1993
Accord.....	1994-1997
Accord.....	1998-2002
Civic.....	1999-2000
CR-V.....	1997-2001
CR-V.....	2002-2006
Odyssey.....	1995-1999
Odyssey (without NAV).....	1999-2004
Prelude.....	1992-1996
Prelude.....	1997-2001

Isuzu

Oasis.....	1996-1999
------------	-----------

Table of Contents

Dash Disassembly

– Acura CL 1997-1999.....	3
– Acura Integra 1990-1993.....	3
– Acura Integra 1994-2001.....	4
– Acura Legend 1990-1995.....	4
– Acura TL 1996-1998.....	5
– Acura Vigor 1992-1994.....	5
– Honda Accord 1990-1993.....	6
– Honda Accord 1994-1997.....	6
– Honda Accord 1998-2002.....	7
– Honda Civic 1999-2000.....	7
– Honda CR-V 1997-2001.....	8
– Honda CR-V 2002-2006.....	8
– Honda Odyssey 1995-1999.....	9
– Honda Odyssey 1999-2004 (without NAV).....	9

– Honda Prelude 1992-1996.....	10
– Honda Prelude 1997-2001.....	10
– Isuzu Oasis 1996-1999.....	9

Kit Assembly

– Double DIN radio provision.....	11-12
– Stacked ISO radio provision.....	11-12
– Final Assembly.....	13

Acura CL 1997-1999

1. Unclip the radio trim bezel and disconnect the clock and climate control wiring. Remove (2) 8mm hex-head screws securing the factory radio and disconnect the wiring. (Figure A)
2. Cut and remove all mounting clips on the radio rousing EXCEPT clips "A" and "H". (Figure B)

Continue to kit assembly

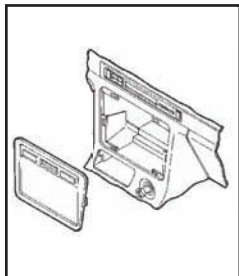

(Figure A)

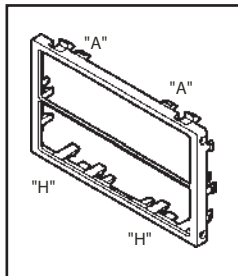

(Figure B)

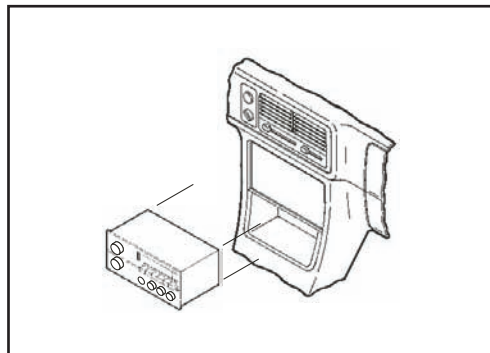

(Figure A)

Acura Integra 1990-1993

1. Remove (3) screws from each side of the center console and remove the console. Remove (2) screws securing the factory radio to the sub-dash support bracket. Slide the radio/pocket assembly out and disconnect the wiring. (Figure A)
2. Cut and remove the mounting tabs from the bottom of the rear support tray (Figure B, A). Cut and remove all mounting clips on the radio rousing EXCEPT clips "C" and "H" (Figure B, B).

Continue to kit assembly

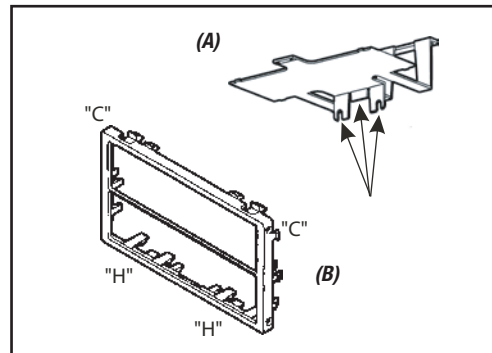

(Figure B)

Acura Integra 1994-2001

1. Remove the cover cap located under the emergency brake and remove (2) screws exposed. Remove (2) screws from the rear corners of the lower dash trim bezel and remove. Remove the ashtray and (2) screws exposed. Unsnap the ashtray housing and disconnect the cigarette lighter harness. Remove the gear shifter knob and unsnap the shifter trim. Remove (2) screws below the radio opening and remove the upper dash trim bezel. Remove (2) 8mm screws securing the factory radio and disconnect the wiring. (Figure A)
2. Cut and remove all mounting clips on the radio rousing EXCEPT clips "C" and "H" (Figure B, A). Cut and remove the slots on the bottom of the ISO brackets (Figure B, B). **Note:** The rear support tray will not be used. (Figure B)

Continue to kit assembly

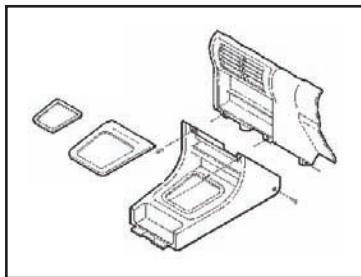

(Figure A)

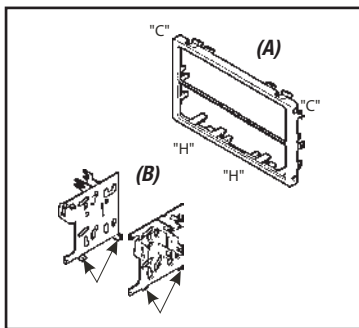

(Figure B)

Acura Legend 1990-1995

1. Remove (2) screws below the ashtray. Unclip the dash trim bezel. Disconnect the cigarette lighter wiring and remove the bezel. Remove (2) bolts securing the rear of the factory radio and disconnect the wiring. (Figure A)
2. Attach the mounting bracket to the bottom of the rear support tray (Figure B, A). Cut and remove all mounting clips on the radio rousing EXCEPT clips "E" and "J" (Figure B, B).

Continue to kit assembly

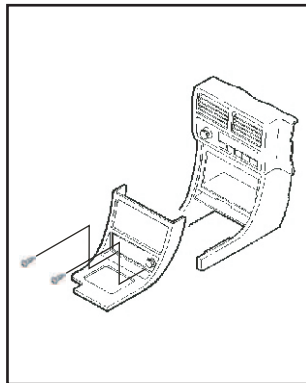

(Figure A)

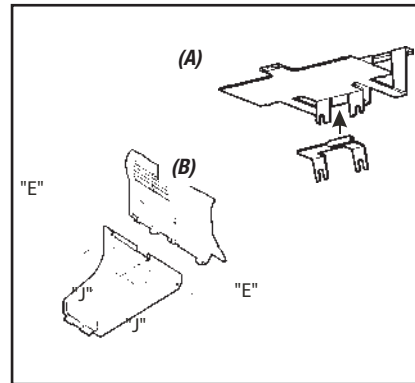

(Figure B)

Acura TL 1996-1998

- Using a small screwdriver, unclip the perimeter of the radio trim bezel. Disconnect the climate control and rear defroster wiring and remove the bezel. Remove (4) Phillips screws securing the factory radio/trim bezel assembly. Loosen (2) Phillips screws securing the back of the radio to the metal housing and slide the radio out (it is NOT necessary to remove the screws securing the metal housing to the bezel). Disconnect the wiring. (Figure A)
- Cut and remove the mounting tabs (Figure B, B) from the bottom of the rear support tray (Figure B, A). Cut and remove all mounting clips on the radio rousing EXCEPT clips "B" and "K" (Figure B, B). Cut and remove the slots on the bottom of the ISO brackets (Figure B, C).

Continue to kit assembly

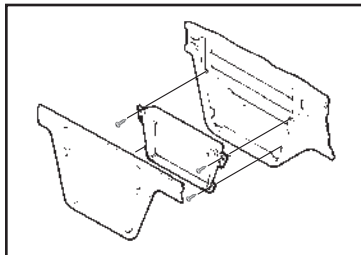

(Figure A)

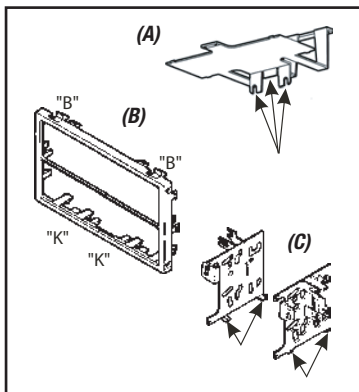

(Figure B)

Acura Vigor 1992-1994

- Remove the access cap from the climate control cluster and (1) screw exposed. Unclip the cluster and remove (2) screws exposed. Remove the ashtray and (2) Phillips screws exposed. Remove the cover caps from each front corner of the center console and the screws exposed. Open the storage compartment, lift up the carpet and remove (2) screws exposed. Lift up on the center console and remove. Unclip the radio trim bezel and disconnect the wiring. Remove (2) bolts from the back of the factory radio and disconnect the wiring. (Figure A)
- Cut and remove the mounting tabs from the bottom of the rear support tray (Figure B, A). Cut and remove all mounting clips on the radio rousing EXCEPT clips "A" and "H" (Figure B, B).

Continue to kit assembly

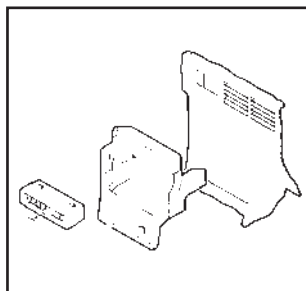

(Figure A)

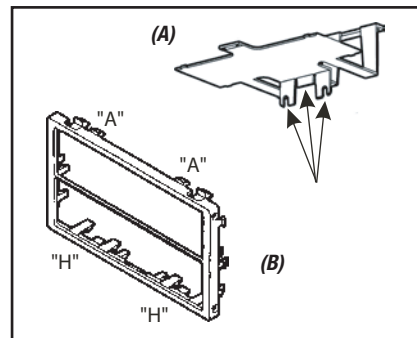

(Figure B)

Honda Accord 1990-1993

1. Remove (4) screws from the lower portion of the center console. Remove the gear shifter knob and lift the console out. Remove the ashtray and ashtray bracket. Remove (2) screws from the bottom of the radio support, slide the radio out and disconnect the wiring. (Figure A)
2. Cut and remove all mounting clips on the radio rousing EXCEPT clips "C" and "H" (Figure B, A). Cut and remove the slots on the bottom of the ISO brackets (Figure B, B). **Note:** The rear support tray will not be used. (Figure B)

Continue to kit assembly

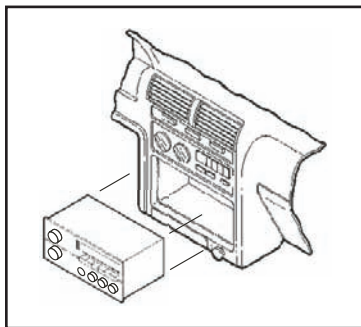

(Figure A)

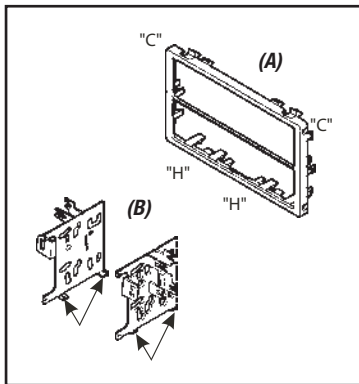

(Figure B)

Honda Accord 1994-1997

1. Remove the ashtray and (1) 3/4" #8 Phillips screw exposed. Open the storage compartment and remove (2) #8 Phillips screws exposed. Remove the cup holder tray and (3) #8 Phillips screws inside. Lift the center console out and remove (2) Phillips screws exposed at the base of the dash trim bezel. Unclip the bezel and remove. Remove (2) hex-head screws securing the factory radio and disconnect the wiring. (Figure A)
2. Cut and remove all mounting clips on the radio rousing EXCEPT clips "A" and "H". (Figure B)

Continue to kit assembly

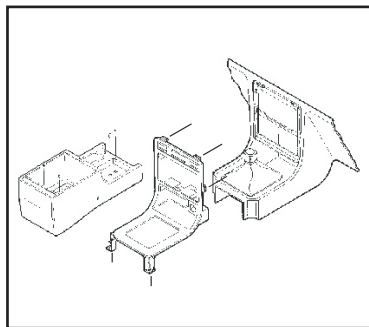

(Figure A)

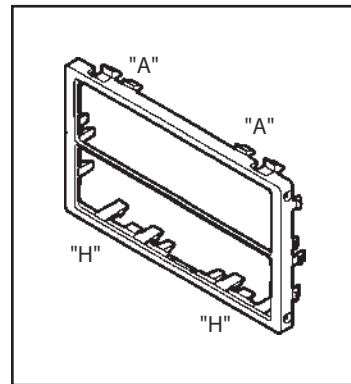

(Figure B)

Honda Accord 1998-2002

1. Unsnap the clock panel, disconnect the wiring and remove. Remove (1) Phillips screw exposed in the clock cavity. Remove (2) Phillips screws below the factory radio. Unclip the radio trim bezel and disconnect the wiring. Remove (4) Phillips screws securing the factory radio assembly and disconnect the wiring. Remove (2) screws securing the factory pocket to the assembly. (Figure A)
2. Cut and remove the mounting tabs from the bottom of the rear support tray (Figure B, A). Cut and remove the slots on the bottom of the ISO brackets (Figure B, B). Locate tabs "A" on the ISO brackets for mounting, cut and remove tabs "B" (Figure B, C). Cut and remove all mounting clips on the radio rousing.

Continue to kit assembly

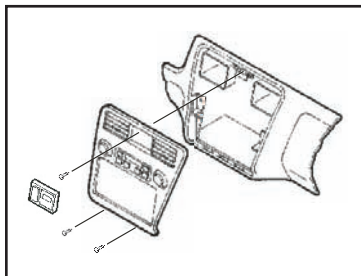

(Figure A)

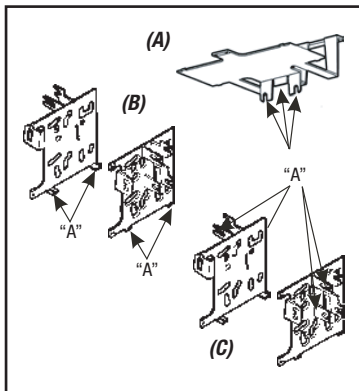

(Figure B)

Honda Civic 1999-2000

1. Remove (2) Phillips screws from the bottom edge of the glove box door and remove the door. Remove (3) Phillips screws from the lower steering column panel. Pull straight down on the lower steering column panel and remove the panel. Remove (2) Phillips screws under the climate controls. Remove (4) Phillips screws from the lower dash location. Remove (4) Phillips screws securing the bottom of the dash trim bezel/radio assembly and pull the assembly out as far as possible. Cut the zip ties securing the radio and climate control wires, slide dash trim bezel/radio assembly from the dash cavity and disconnect the wiring. (Figure A)
2. Cut and remove all mounting clips on the radio rousing EXCEPT clips "B" and "H". (Figure B)

Continue to kit assembly

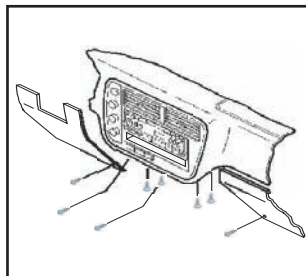

(Figure A)

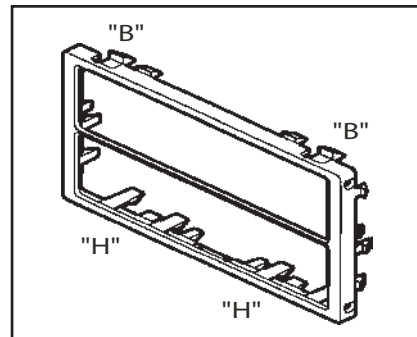

(Figure B)

Honda CR-V 1997-2001

1. Open the glove box, squeeze the retaining clips and remove the stoppers. Lower the glove box and remove (2) Phillips screws from the left edge. Remove (2) Phillips screws from the lower steering column panel and remove. Unclip the lower console cover (below the ashtray and pocket) and remove. Remove (2) Phillips screws from the base of the center console, open the console pocket and remove the (4) outer screws exposed. Unclip the center console and remove. Remove (2) Phillips screws securing the radio trim bezel, disconnect the wiring, and remove the trim bezel/radio

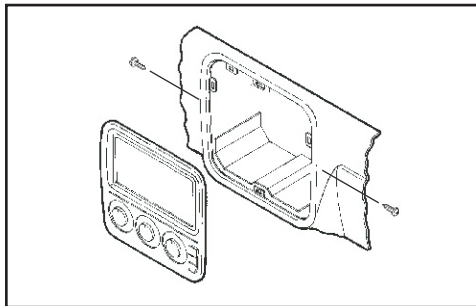

(Figure A)

- assembly. Remove (4) Phillips screws securing the radio to the bezel and remove. (Figure A)
2. Cut and remove all mounting clips on the radio rousing EXCEPT clips "B" and "H" (Figure B, A). Cut and remove the slots on the bottom of the ISO brackets (Figure B, B).

Continue to kit assembly

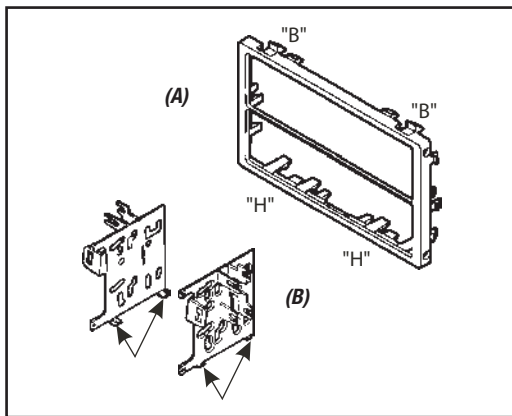

(Figure B)

Honda CR-V 2002-2006

1. Remove (2) Phillips from the bottom edge of the radio trim bezel. Unclip the trim bezel and remove. Remove (4) Phillips screws securing the factory radio and disconnect the wiring. (Figure A)
2. Cut and remove all mounting clips on the radio rousing EXCEPT clips "C" and "H". (Figure B)

Continue to kit assembly

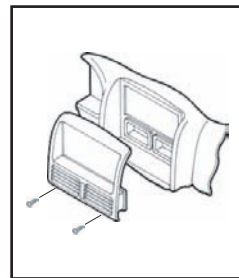

(Figure A)

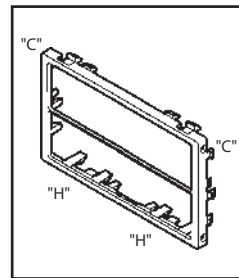

(Figure B)

Honda Odyssey 1995-1999, Isuzu Oasis 1996-1999

1. Lower the glove box assembly. Remove (2) Phillips screws exposed on the right side of the underdash. Remove (2) Phillips screws from the driver's side knee bolster and (1) Phillips screw in the coin pocket. Remove (5) Phillips screws from the underdash panel and remove the panel. Remove (4) Phillips screws from the cup holder assembly and remove. Remove (2) Phillips screws securing the factory radio and disconnect the wiring. (Figure A)
2. Cut and remove all mounting clips on the radio rousing EXCEPT clips "D" and "H" (Figure B, A). Cut and remove the slots on the bottom of the ISO brackets (Figure B, B). **Note:** The rear support tray will not be used. (Figure B)

Continue to kit assembly

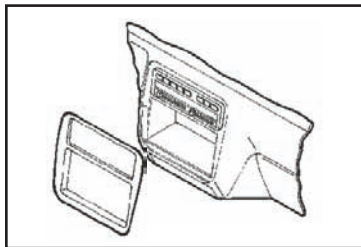

(Figure A)

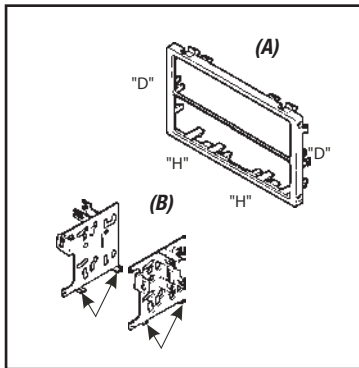

(Figure B)

Honda Odyssey (without NAV) 1999-2004

1. Unclip the radio trim bezel (including the climate control panel) and remove. Remove (4) Phillips screws securing the factory radio and disconnect the wiring. (Figure A)
2. Cut and remove the mounting tabs from the bottom of the rear support tray (Figure B, A). Cut and remove the slots on the bottom of the ISO brackets (Figure B, B). Locate tabs "B" on the ISO brackets for mounting, cut and remove tabs "A" (Figure B, C). Cut and remove all mounting clips on the radio rousing. (Figure B)

Continue to kit assembly

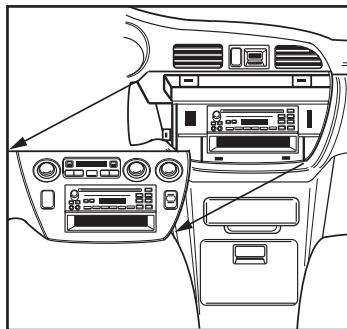

(Figure A)

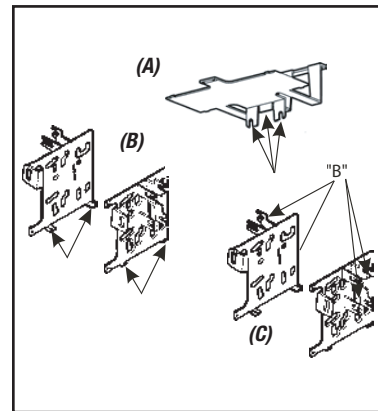

(Figure B)

Honda Prelude 1992-1996

1. Remove (2) screws from the top of the console trim bezel. Slide the front seats back and remove (4) Phillips screws from each side of the bezel. Pull up on the console trim bezel and remove. Using an angled screwdriver, remove (2) screws securing the gear shifter bracket to the bezel. Remove (4) screws from the radio trim bezel, remove the factory radio assembly and disconnect the wiring. (Figure A)
2. Cut and remove the mounting tabs from the bottom of the rear support tray (Figure B, A). Cut and remove all mounting clips on the radio rousing EXCEPT clips "F" and "H" (Figure B, B). Cut and remove the slots on the bottom of the ISO brackets (Figure B, C).

Continue to kit assembly

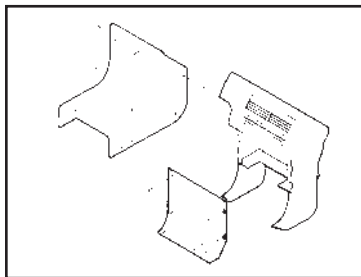

(Figure A)

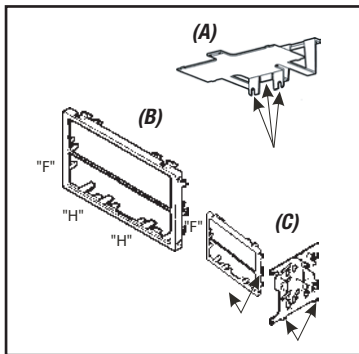

(Figure B)

Honda Prelude 1997-2001

1. Using a panel removal tool, unclip the radio trim bezel and remove (some force may be required). Remove (4) Phillips screws securing the factory radio/bracket housing assembly and disconnect the wiring. Remove (4) Phillips screws securing the factory radio to the bracket housing and remove. (Figure A)
2. Cut and remove all mounting clips on the radio rousing EXCEPT clips "A" and "G". (Figure B)

Continue to kit assembly

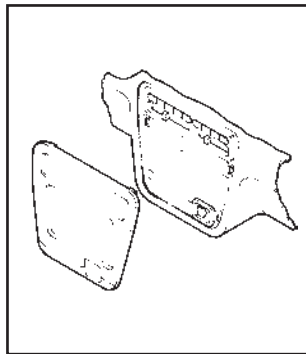

(Figure A)

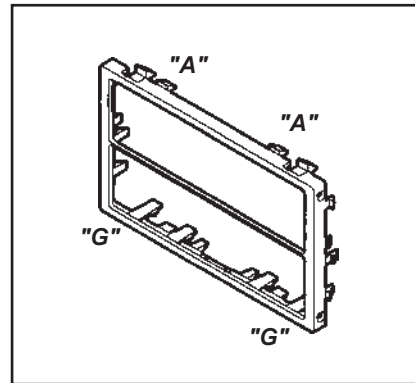

(Figure B)

Attention: Use the steps below for the following vehicles: CR-V 1997-2001, Prelude 1997-2001, Civic 1999-2000. For all other vehicles skip to next kit assembly section.

CR-V Double DIN radio provision:

Slide the radio into the factory bracket assembly. Align the holes in the brackets with the holes in the radio and secure with the screws included with the radio. Cut and remove the dividing rib from the radio rousing and snap the Housing into the opening. (Figure A)

ISO Stacked radio provision:

Slide the aftermarket radio (and digital sound processor, equalizer, etc.) into the ISO brackets and mount the lower radio to the brackets with the screws included with the radio. Slide the radios into the factory bracket assembly. Align the holes in the brackets with the holes in the upper radio and secure with the screws included with the radio. Snap the radio rousing into the radio opening. (Figure B)

Prelude Double DIN radio provision:

Slide the radio into the factory bracket assembly. Align the holes in the brackets with the holes in the radio and secure with the screws included with the radio. Cut and remove the dividing rib from the radio housing and snap the housing into the opening. (Figure C)

ISO Stacked radio provision:

Slide the aftermarket radio (and digital sound processor, equalizer, etc.) into the factory bracket assembly. Align the holes in the brackets with the holes in the radios and secure with the screws included with the radios. Snap the radio rousing into the radio opening. (Figure D)

Civic Double DIN radio provision:

Slide the radio into the factory bracket assembly. Align the holes in the brackets with the holes in the radio and secure with the screws included with the radio. Cut and remove the dividing rib from the radio rousing and snap the Housing into the opening. (Figure E)

ISO Stacked radio provision:

Slide the aftermarket radio (and digital sound processor, equalizer, etc.) into the factory bracket assembly. Align the holes in the brackets with the holes in the radios and secure with the screws included with the radios. Snap the radio rousing into the radio opening. (Figure F)

Continue to final assembly

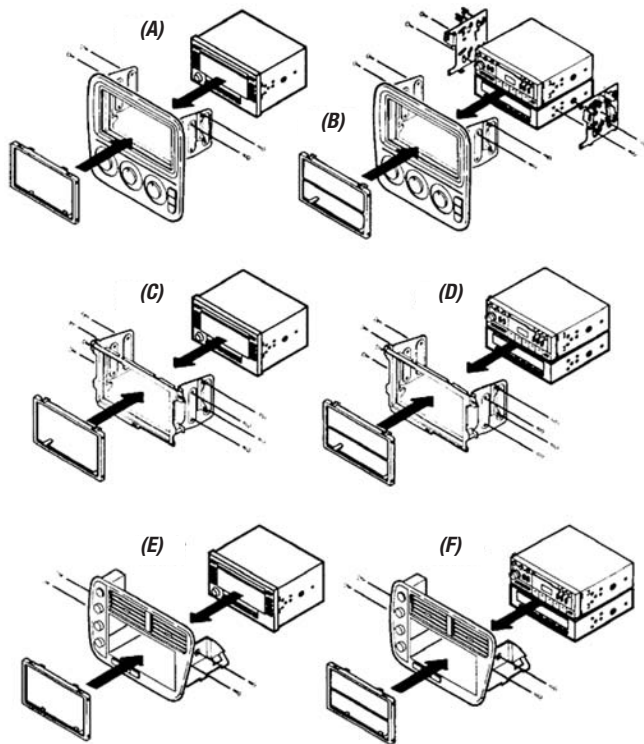

Double DIN radio provision:

Cut and remove the dividing rib from the radio opening. Cut and remove all mounting tabs on the ISO brackets, align the holes in the brackets with the holes in the radio and secure with the screws included with the radio. Slide the rear support tray under the radio. Position the radio rousing over the radio and mount to the ISO brackets with (4) #6 x 1/4" flat-head screws supplied and to the rear support tray with (2) #6 x 1/4" flat-head screws supplied. (Figure A, A)

ISO stacked radio provision:

Cut and remove all mounting tabs on the ISO brackets, align the holes in the brackets with the holes in the radios and secure with the screws included with the radios. Slide the rear support tray under the radios. Position the radio rousing over the radios and mount to the ISO brackets with (4) #6 x 1/4" flat-head screws supplied and to the rear support tray with (2) #6 x 1/4" flat-head screws supplied. (Figure A, B)

Continue to next kit assembly section

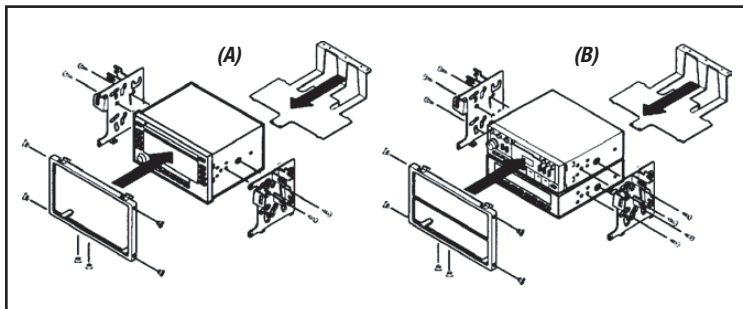

(Figure A)

Attention: Use the steps below for the following vehicles: Accord 1994-1997, CR-V/Prelude 1997-2001, Civic 1999-2000, Accord 1990-1993, Odyssey 1995-1998, Prelude 1992-1996, Integra/Oasis/Vigor/TL, Accord 1998-2002, Odyssey 1999-2002. For all other vehicles skip to final assembly section.

Accord 1994-1997, CL:

Secure the mounting bracket (mounted to the bottom of the rear support tray) to the rear support provision in the sub-dash with (2) bolts previously removed. (Figure A)

CR-V, Prelude 1997-2001, Civic 1999-2000:

Snap the radio/trim bezel assembly into the subdash. (Figure A)

Accord 1990-1993, Odyssey 1995-1998, Prelude 1992-1996, Integra, Oasis, Vigor, TL:

Snap the radio/kit assembly into the subdash. (Figure A)

Accord 1998-2002, Odyssey 1999-2002:

Mount the radio/kit assembly to the subdash with the (4) screws previously removed. (Figure A)

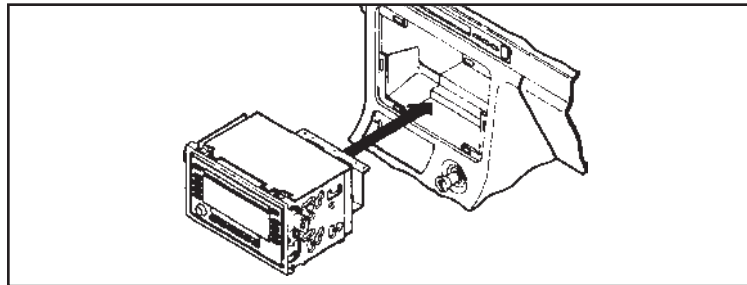

(Figure A)



INSTALLATION INSTRUCTIONS FOR PART 95-7801



REV 12/9/2013 INST95-7801



KNOWLEDGE IS POWER

Enhance your installation and fabrication skills by enrolling in the most recognized and respected mobile electronics school in our industry. Log onto www.installerinstitute.com or call 800-354-6782 for more information and take steps toward a better tomorrow.



**Metra recommends MECP
certified technicians**