

The Intermec logo is displayed in a bold, blue, sans-serif font. It is positioned to the left of a square icon containing a white stylized 'Q' on a blue background. The entire logo and icon are set against a background of overlapping light blue circles and lines, resembling an orbital or molecular structure.

Intermec



User's Guide



EasyCoder® PM4i
Bar Code Label
Printer
(Fingerprint Version)

Intermec Technologies Corporation
Corporate Headquarters
6001 36th Ave. W.
Everett, WA 98203
U.S.A.
www.intermec.com

The information contained herein is proprietary and is provided solely for the purpose of allowing customers to operate and service Intermec-manufactured equipment and is not to be released, reproduced, or used for any other purpose without written permission of Intermec.

Information and specifications contained in this document are subject to change without prior notice and do not represent a commitment on the part of Intermec Technologies Corporation.

© 2005 by Intermec Technologies Corporation. All rights reserved.

The word Intermec, the Intermec logo, Norand, ArciTech, CrossBar, Data Collection Browser, dcBrowser, Duratherm, EasyCoder, EasyLAN, Enterprise Wireless LAN, EZBuilder, Fingerprint, i-gistics, INCA (under license), InterDriver, Intermec Printer Network Manager, IRL, JANUS, LabelShop, Mobile Framework, MobileLAN, Nor*Ware, Pen*Key, Precision Print, PrintSet, RoutePower, TE 2000, Trakker Antares, UAP, Universal Access Point, and Virtual Wedge are either trademarks or registered trademarks of Intermec Technologies Corporation.

Throughout this manual, trademarked names may be used. Rather than put a trademark (™ or ®) symbol in every occurrence of a trademarked name, we state that we are using the names only in an editorial fashion, and to the benefit of the trademark owner, with no intention of infringement.

There are U.S. and foreign patents pending.

The name Centronics is wholly owned by GENICOM Corporation.

Kimdura is a registered trademark of Kimberly Clark.

Microsoft is a registered trademark of Microsoft Corporation.

Torx is a registered trademark of Camcar Division of Textron Inc.

TrueDoc is a registered trademark of Bitstream, Inc.

TrueType is a trademark of Apple Computer Inc.

Unicode is a trademark of Unicode Inc.

Valeron is a registered trademark of Valéron Strength Films, an ITW Company.

Windows is a trademark of Microsoft Corporation.

Document Change Record

This page records changes to this document. The document was originally released as version -00.

Version	Date	Description of Change
-00	May 2003	Supports original Fingerprint version (v8.00).
-01	Oct. 2003	Revised to support Fingerprint v8.10. Information about EasyLAN Wireless interface added.
-02	Feb. 2004	Revised to support Fingerprint v8.20 and Intermec Shell v8.1. Information on Intermec Readiness Indicator added.
-52	June 2004	New method for returning to factory default added. New setup node for LSS test added. More bar codes supported.
-03	August 2004	Revised to support Fingerprint v8.30 and Intermec Shell v8.2. Full support for double optional interface boards including up to five serial communication ports. Support for composite bar codes.
-04	January 2006	Revised to support Fingerprint v8.70. RFID functionality and description of the Ready-to-Work indicator has been added.

Version -00 to -09 are original versions in US English.

Version -50 to -59 are Chinese translations.

Contents

Before You Begin.....	ix
Safety Summary.....	ix
Safety Icons	x
Global Services and Support	xi
Warranty Information.....	xi
Web Support	xi
Telephone Support	xi
Related Documents	xi

1 Introduction

Description of EasyCoder PM4i Printer.....	2
Safety Summary	3
Product Identification	3

2 Installation

Unpacking the Printer.....	6
Front View.....	7
Rear View	8
Media Compartment	9
Description.....	9
Media Supply Roll Post.....	10
Print Mechanism.....	11
Connections.....	12
Power.....	12
Computer.....	12
Controls and Indicators.....	13
Indicator Lamps	13
Display	14
Keyboard	14
Beeper	15

3 Starting Up

Startup Files	18
Memory Card	19
Switching On the Printer	20

4 Media Load

Tear-Off (Straight-through)	22
Peel-Off (Self-strip)	26
Cut-Off.....	31
External Supply (Fan-fold)	35
Rotating Media Supply	36

5 Thermal Transfer Printing

Ribbon Load.....	38
------------------	----

6 Setting Up the Printer

Description	44
Default Setup.....	45
Reading the Current Setup.....	46
Setup Parameters.....	47
Serial Communication.....	47
Feedadjust	50
Media	52
Print Defines	58
Returning to Factory Default Setup	60

7 Setup Mode

Entering Setup Mode at Installation.....	62
Navigating in Setup Mode	63

8 Intermec Shell Startup Program

Introduction	66
Starting with Intermec Shell.....	68
Intermec Shell v8.2 Overview	72
Line Analyzer	73

9 Options

Introduction	76
Integral Liner Takeup Unit.....	77
Paper Cutter.....	77
Media Supply Hub.....	77
Paper Sensor.....	77

Tear-Off Bar.....	77
Media Roll Retainer	77
3-inch Adapter.....	78
Label Taken Sensor.....	78
Real Time Clock	78
External Keyboard Converter.....	78
Internal Fan-Fold Guide.....	78
Side Door with Keylock.....	78
Font Card	79
CompactFlash Protection Plate	79
RFID Kit	79
Special Printheads	79
Interface Boards	79

10 Troubleshooting

Ready-to-Work indicator	82
-------------------------------	----

11 Maintenance

Printhead Cleaning	88
Cleaning the Media Guides.....	92
Printhead Replacement	93
Media Jams	96

12 Adjustments

Narrow Media.....	98
Label Stop Sensor.....	99
Printhead Pressure.....	102
Ribbon Break Shaft.....	103
LTS (Label Taken Sensor).....	104

A Technical Data

B Media Specifications

Media Roll Size	110
Core	110
Roll	110

Contents

Media.....	111
Media with RFID tags/inlays.....	111
Non-Adhesive Strip	111
Self-Adhesive Strip.....	112
Self-Adhesive Labels.....	113
Tickets with Gaps.....	115
Tickets with Black Mark.....	117

C Interfaces

RS-232 Interface.....	120
Protocol.....	120
Interface Cable	120
USB Interface	121
Bar Code Wand Interface.....	122
Optional Interfaces	123

D Intermec Supplies

RFID Media	128
Direct Thermal Media.....	128
Premium Quality	128
Economy Quality	128
Thermal Transfer Media.....	129
Uncoated Papers	129
Coated Papers	129
Polyethylene Plastics	129
Transfer Ribbons	130
Bar Code Directions.....	131
Recommended Paper Type Settings (Europe)	132
Recommended Paper Type Settings (North America)	134

E Setup Mode Overviews

Before You Begin

This section provides you with safety information, technical support information, and sources for additional product information.

Safety Summary

Your safety is extremely important. Read and follow all warnings and cautions in this document before handling and operating Intermec equipment. You can be seriously injured, and equipment and data can be damaged if you do not follow the safety warnings and cautions.

Do not repair or adjust alone

Do not repair or adjust energized equipment alone under any circumstances. Someone capable of providing first aid must always be present for your safety.

First aid

Always obtain first aid or medical attention immediately after an injury. Never neglect an injury, no matter how slight it seems.

Resuscitation

Begin resuscitation immediately if someone is injured and stops breathing. Any delay could result in death. To work on or near high voltage, you should be familiar with approved industrial first aid methods.

Energized equipment

Never work on energized equipment unless authorized by a responsible authority. Energized electrical equipment is dangerous. Electrical shock from energized equipment can cause death. If you must perform authorized emergency work on energized equipment, be sure that you comply strictly with approved safety regulations.

Safety Icons

This section explains how to identify and understand dangers, warnings, cautions, and notes that are in this document. You may also see icons that tell you when to follow ESD procedures.



Warning

A warning alerts you of an operating procedure, practice, condition, or statement that must be strictly observed to avoid death or serious injury to the persons working on the equipment.



Caution

A caution alerts you to an operating procedure, practice, condition, or statement that must be strictly observed to prevent equipment damage or destruction, or corruption or loss of data.



**Follow ESD
Procedures**

This icon appears at the beginning of any procedure in this manual that could cause you to touch components (such as printed circuit boards) that are susceptible to damage from electrostatic discharge (ESD). When you see this icon, you must follow standard ESD guidelines to avoid damaging the equipment you are servicing.



Note: Notes either provide extra information about a topic or contain special instructions for handling a particular condition or set of circumstances.

Global Services and Support

Warranty Information

To understand the warranty for your Intermec product, visit the Intermec web site at <http://www.intermec.com> and click Service & Support. The Intermec Global Sales & Service page appears. From the Service & Support menu, move your pointer over Support, and then click Warranty.

Web Support

Visit the Intermec web site at <http://www.intermec.com> to download our current documents in PDF format. To order printed versions of the Intermec manuals, contact your local Intermec representative or distributor.

Visit the Intermec technical knowledge base (Knowledge Central) at <http://intermec.custhelp.com> to review technical information or to request technical support for your Intermec product.

Telephone Support

Contact your local Intermec representative. To search for your local representative, from the Intermec web site, click **Contact**.

Related Documents

The Intermec web site at <http://www.intermec.com> contains our current documents that you can download in PDF format. To order printed versions of the Intermec manuals, contact your local Intermec representative or distributor.

Before You Begin



1 Introduction

This chapter introduces the EasyCoder PM4i printer. The chapter covers the following topics:

- Description of EasyCoder PM4i
- Safety summary
- Product identification

Description of EasyCoder PM4i Printer

The EasyCoder PM4i is a sturdy thermal transfer printer with a printhead resolution of 8 dots/mm = 203.2 dot/inch (standard) or 11.81 dots/mm = 300 dots/inch (option) and a maximum print width of 104 mm (4.095 inches) or 105.7 mm (4.161 inches) respectively. It offers a large number of useful features, such as:

- Flash memory SIMMs for firmware, fonts, bar codes, and application programs
- Built-in CompactFlash memory card adapter
- Built-in RS-232 and USB interfaces
- Provision for extra interface boards including wireless EasyLAN connections and RFID capability.
- Keyboard and display with backlight for improved user interface.

A large number of factory-installed or field-installable options are available, so the printer can be configured for a wide range of applications. See Chapter 9 and Appendix A for more information.

The EasyCoder PM4i supports the unique and flexible Intermec Fingerprint v8.70 programming language, which allows the user or third-party developer to create custom-made application programs and label formats in a BASIC-like environment.

The printer is also designed to work with the Intermec Direct Protocol programming language, the Intermec InterDriver and Intermec Labelshop. The InterDriver allows you to print labels from standard MS Windows applications, for example Microsoft Office. Intermec LabelShop is a series of label-design programs that work under various versions of MS Windows.

The EasyCoder PM4i Compact supports 15 scaleable Unicode TrueType and TrueDoc fonts as standard. Additional fonts can be downloaded into the printer's Flash memory, or be plugged in using a CompactFlash card. The Unicode standard allows the use of special characters for various languages including non-Latin fonts, such as Arabic, Cyrillic, Chinese, Japanese, Korean, Hebrew, and similar.

A version of EasyCoder PM4i, that supports the Intermec Programming Language (IPL), is described in a special User's Guide.

Safety Summary

Intermec assumes no responsibility regarding the CE Directive if the printer is handled, modified, or installed in any way other than that described in Intermec's manuals.

- Read this manual carefully before connecting the printer.
- Moving parts are exposed when the side doors are open, so ensure that the doors are closed before you operate the printer.
- Do not open the front/left-hand electronics cover. Dangerous voltage!



If you open the electronics cover, you will void the warranty and may cause damage to the internal components. Opening the electronics cover exposes the user to shock hazards which may result in injury or death.

- Do not remove the bottom plate. Dangerous voltage!
- Do not put your fingers inside the print mechanism when the power is on.
- Make sure that the side door cannot unintentionally swing down when you have your fingers or hands inside the media compartment. Risk of injury because of the weight of the side door!
- Place the printer on an even surface which can support its weight of approximately 13.5 kg (30 pounds) plus supplies.
- Do not spray the printer with water. If you are using a hose to clean the premises in an industrial environment, remove the printer or protect it carefully from spray and moisture.
- Carefully read the warning text on the envelope before using a cleaning card.

Product Identification

The machine label is attached to the printer's rear plate and contains information on type, model, and serial number as well as AC voltage. It also contains various signs of approval.



2 Installation

This chapter explains how to unpack and install the EasyCoder PM4i and also describes the printer's various parts in detail. It covers the following topics:

- Unpacking the printer
- Parts on the printer's front
- Parts on the printer's rear plate
- Parts in the media compartment
- Parts in the print mechanism
- Connecting the printer
- Using the controls and understanding the indicators

Unpacking the Printer

Before you install the printer, examine the package for possible damage or missing parts:

- Open the box and lift the printer out.
- Check that the printer has not been visibly damaged during transportation. Keep the packing materials in case you need to move or reship the printer.
- Check the label on the printer's rear plate, which gives the voltage, the part number, and the serial number.
- Check that any options you ordered are included.
- Check that all the accessories are included. As standard, the box contains:
 - Intermec EasyCoder PM4i printer
 - Power cord
 - Quality check card
 - Cleaning card
 - High edge guide for media supply post
 - This User's Guide
 - Supporting software and product information on CD.
- Check that the type of power cord is appropriate for the local standard. The printer works within 90 to 265 VAC, 50 to 60 Hz.

If the printer has been damaged in any way during transportation, complain to the carrier immediately.

If the delivery is incorrect or any parts are missing, report it immediately to the distributor.

Front View

At the front of the printer are the display window, the control lamps, and the keyboard. These features allow the operator to control and set up the printer manually.

The printed labels, tickets, or tags are presented at the front of the print mechanism, which is covered by a door.

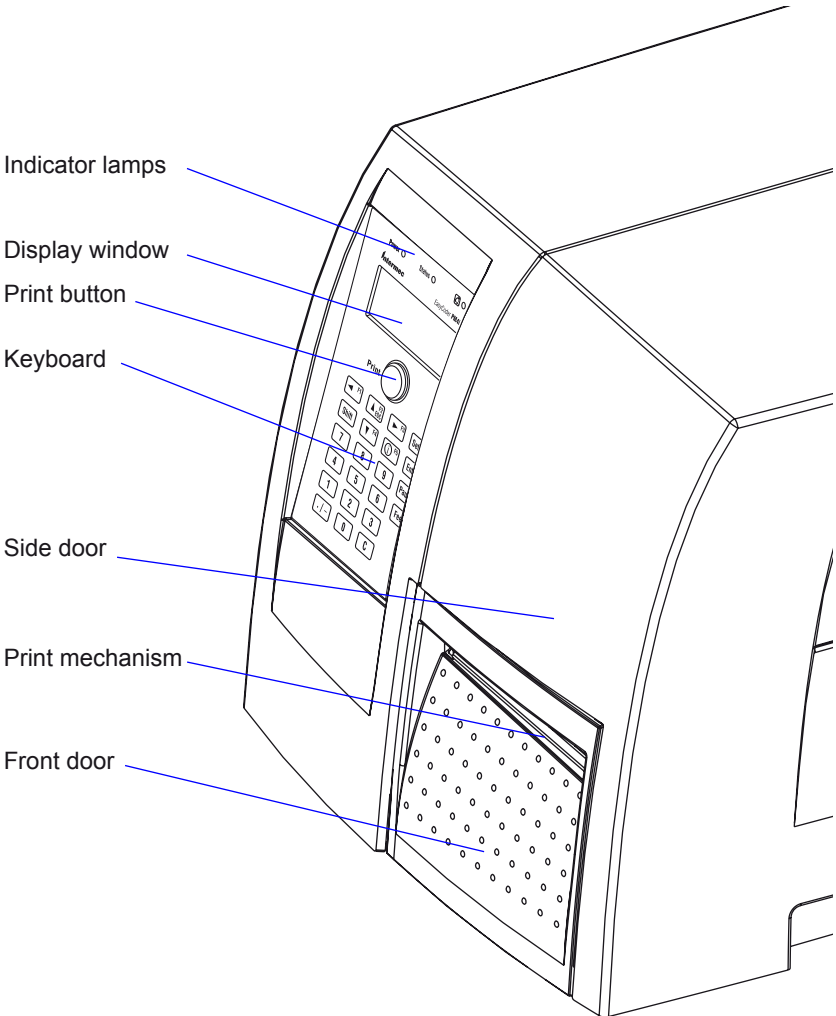

Rear View

The rear plate contains the On/Off switch, the AC power cord socket, and various interface connectors and slots.

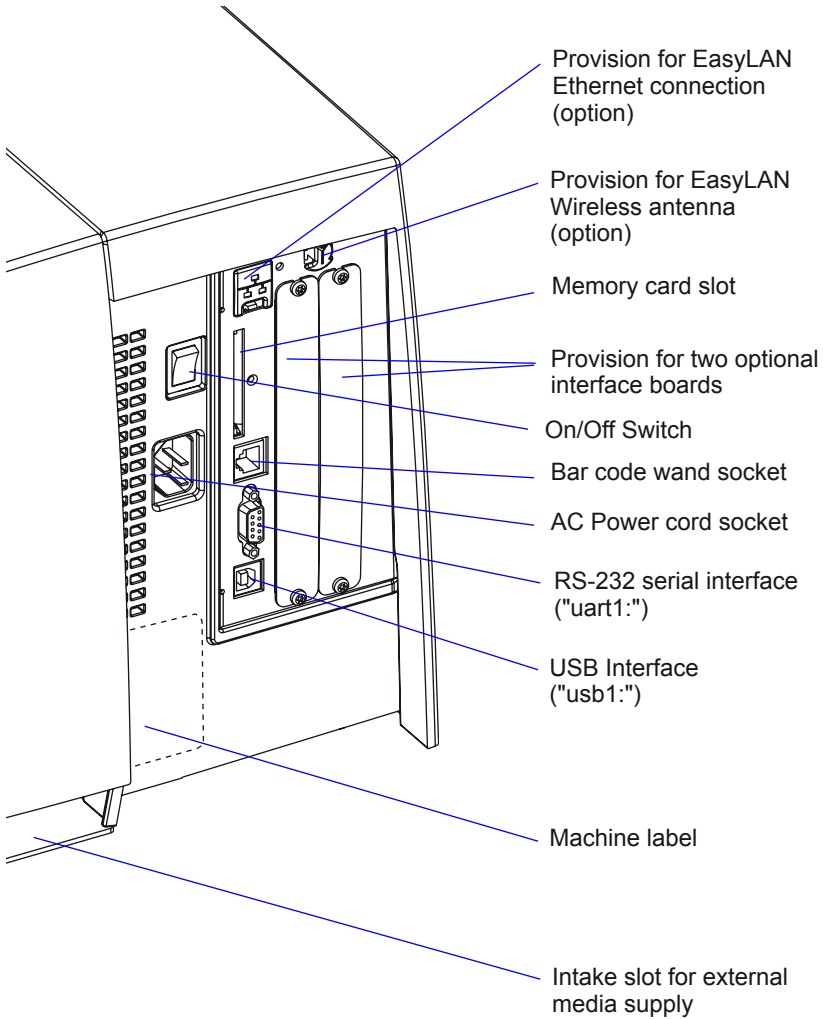

Media Compartment

Description

The media compartment is completely covered by a door that can be opened 180° upwards to provide full access for media and ribbon load and has an inspection window for checking the media and transfer ribbon supplies.

The media can be supplied from a post or, optionally, from an external supply of fan folds behind the printer using an internal media guide device. There is also an optional rotating media supply hub. Also see Chapter 9, “Options.”

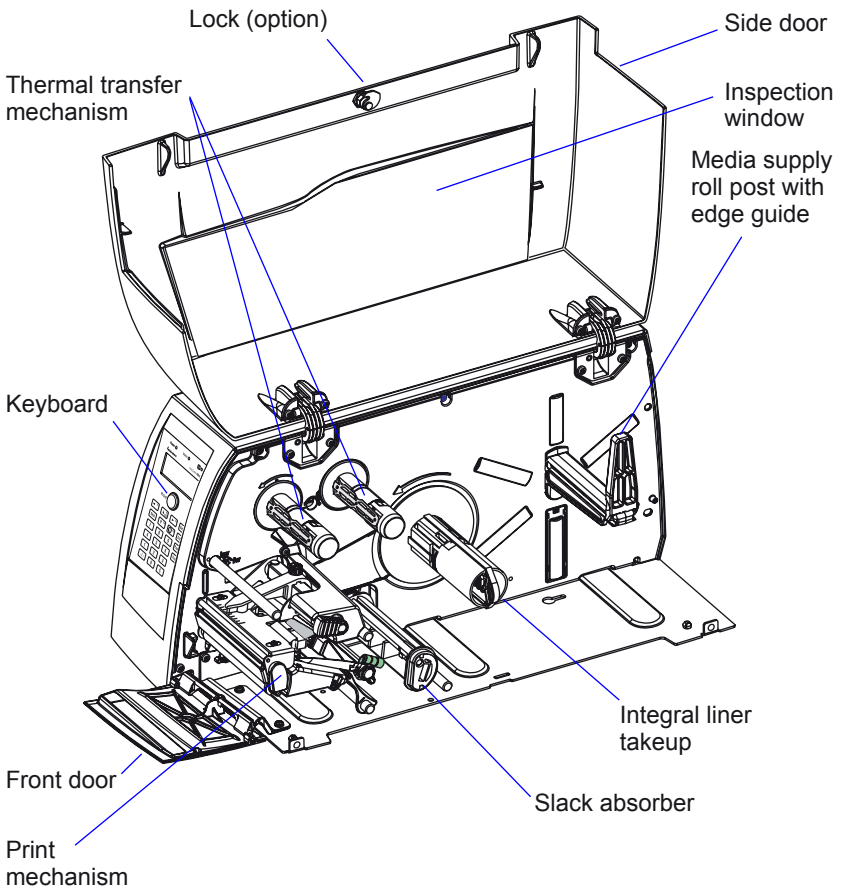

Media Supply Roll Post

The media supply roll post fits both 38-40 mm (1.5 inches) and 76 mm (3.0 inches) cores because it can be moved up or down in a slot in the center section. The bottom position is intended for small cores and the top position is for large cores. The post is locked by a straight-slot screw.

The post has a moveable edge guide to fit various media widths. As standard, a low guide is factory-fitted on the post and a high guide is packed separately with the other printer accessories. When switching the edge guide, be careful not to break it. In this manual, the high edge guide is generally illustrated.

When the edge guide is in its outermost position, it can be tilted down to a horizontal attitude to allow removal of the empty core and loading of a new media roll. After loading the media roll, tilt up the edge guide and push it inwards so the media roll becomes flush with the center section. The low edge guide allows media rolls with 3-inch cores to be loaded without tilting down the guide.

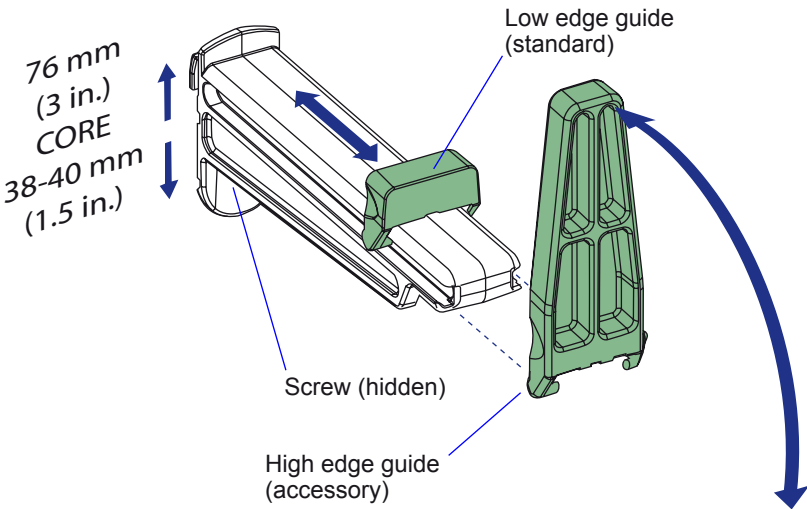

Optionally, the printer can be fitted with an 1.5-inch rotating media supply hub instead of a post and a paper sensor, which detects when the remaining amount of media has reached a level specified in the Setup Mode. There is also a 3-inch adapter and a label roll retainer. Another option is an internal guide for media placed behind the printer (for example fan-folds). For illustrations, see Chapter 9 “Options”.

Print Mechanism

The print mechanism features a high-performance thermal printhead with quick-mount fittings to facilitate replacement.

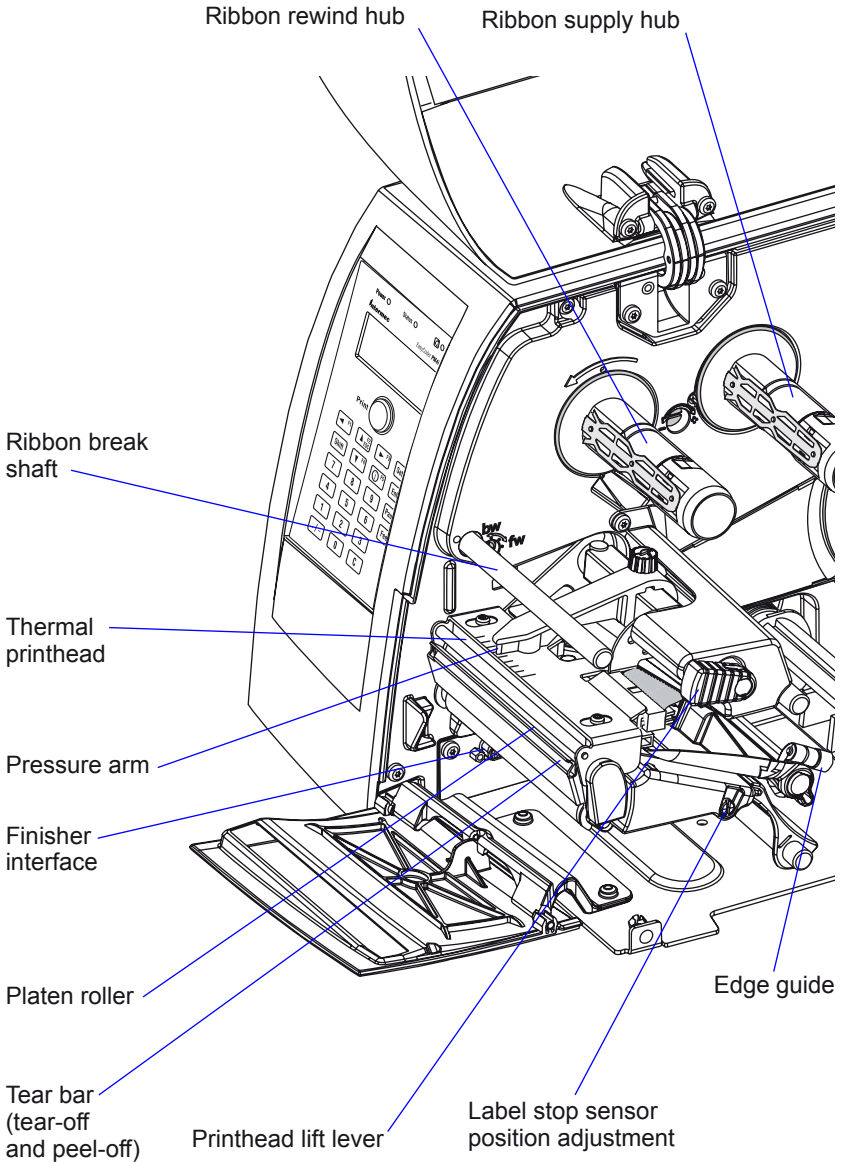

Connections

Power

- 1 Place the printer on a level surface, near an AC outlet. You should be able to access the printer to load supplies and to remove the printout.
- 2 Check that the printer is switched off.
- 3 Connect the power cord from the socket on the rear plate to an electrical outlet (90 to 265 VAC).

Computer

The EasyCoder PM4i is fitted with one 9-pin D-style subminiature (DB9) socket for the RS-232 serial interface port and one class B connector for the USB interface port (see Appendix C).

RS-232 Serial Interface ("uart1:")

Use the serial interface with Intermec LabelShop or the Intermec InterDriver. Also use it with the Intermec Direct Protocol or the Intermec Fingerprint programming language because you can receive error messages from your printer. Before you can use the serial interface, you may need to set up the communication parameters, such as baud rate, parity, etc. as described in Chapter 6, “Setting Up the Printer.”

USB Interface ("usb1:")

Use the USB interface with an USB-compatible version of the Intermec InterDriver for printing. The USB interface is not suitable for programming because the host cannot receive error messages from your printer.

Optional Interface and Network Boards

("uart2:", "uart3:", "uart4:", "uart5:", "centronics:", and "net1:")

Several types are available (see Chapter 9, “Options”). Refer to Chapter 6, Chapter 7, Appendix C and E for connection and setup instructions.

The printer can be set to scan all communication ports. When it detects incoming data on a port, the printer automatically switches to use that port for both input and output. This facility ("auto") can be selected in Intermec Shell (see Chapter 8) or using the Intermec Fingerprint instruction SETSTDIO, see *Intermec Fingerprint v8.xx, Programmer's Reference Manual*. Use the <F5/i> key to get information on the active communication channels.

Switch off both PC and printer before connecting them together.

Controls and Indicators

The EasyCoder PM4i has several ways of communicating directly with its operator: three colored indicator lamps, a display window, a membrane-switch keyboard with 23 programmable keys and buttons on the printer's front, and a beeper.

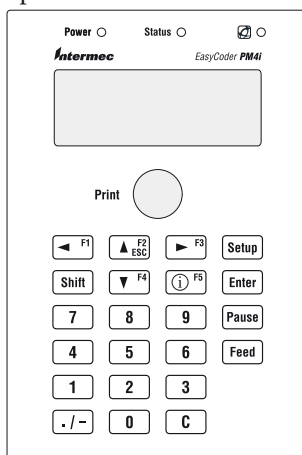

Indicator Lamps

The indicators are colored LEDs (Light Emitting Diodes) and are used for the following purposes:

- Power (solid green) indicates that the power is on.
- Status (solid green) indicates that the printer is ready for use.
- Status (flashing green) indicates that the printer is communicating.
- Status (solid red) indicates an error condition (see Chapter 10).

-  Intermec Ready-to-Work™ (blue; on, blink, or off).
Represented by a blue light on Intermec handheld computers, access points, and printers, the Ready-to-Work indicator is part of an exclusive monitoring system from Intermec. The Ready-to-Work indicator helps users quickly determine the readiness of the Intermec device individually and as part of a solution. The Ready-to-Work indicator has three different states: On, Blinking, and Off. When the Indicator is off, the device is not ready to operate individually or as part of a solution. When the Indicator is blinking, the device may be initializing, waiting for external resources, or in need of user attention. And when the Indicator is On, the device is ready for use as part of a solution. Also see Chapter 10.

Display

The display window contains an LCD (Liquid Crystal Display) with background illumination and two lines of text, each with 16 characters. It provides information on installed firmware or running application, prompts the operator in Intermec Shell and in the Setup Mode, and can show information on possible errors and active communication channels.

The Intermec Fingerprint programming language and the Intermec Direct Protocol allow custom-made messages to be composed and displayed according to the requirements of the application.

Keyboard

The keyboard is of the membrane-switch type and has 22 keys and a “Print” button. Some keys have hard-coded functions in the startup and setup modes.

Print button	Feed/Pause a print job. Repeat last printed label.
Pause	Toggle between pause and printing when executing a print job.
Pause + Shift	Interrupt a running Fingerprint program.
Setup	Enter the Setup Mode (see Chapter 7).
Feed	Feed out a blank label or the equivalent.
Feed + Shift	Perform a Testfeed (feed a blank label, adjust the media feed).
F5 ⓘ	Display error messages, Ready-to-Work status, and communication channel information.
F1 ◀ F3 ▶	Scroll between various types of information after pressing the <F5/i> key. Possible error messages and information on active communication channels are shown in a loop.

In application programs created using the Intermec Fingerprint programming language, the keys can be assigned to various functions or be disabled individually. Since one key is assigned as shift key, up to 44 different key combinations are possible. An audible signal, which can be turned off if so desired, acknowledges that a key has been pressed.

Keyboard Color Code

Yellow	Operation of the printer (operator level)
Green	Setup or service (site or service technician level)
White	Data input to printer (operator or technician level)

Beeper

The beeper notifies the operator when an error has occurred and acknowledges that a key has been pressed. The Intermec Fingerprint programming language allows the key acknowledge signal to be turned off. The frequency and duration of signals can be specified. Thus, it is possible to create different signals for different conditions or even to make the printer play simple melodies!



3 Starting Up

This chapter explains how to start up the printer after installation or after having been switched off. It covers the following topics:

- Startup files
- Memory cards
- Switching on the printer
- Display messages at startup

Startup Files

When the printer is switched on, its behavior depends on the existence of a startup file (autoexec.bat) in its memory. There are two cases:

- A** The printer is only fitted with the Intermecc Shell file-managing program, which allows the operator to choose between a variety of applications and functions.
- B** In addition to Intermecc Shell, the printer is also fitted with a custom-made application program that is design to perform a specific task, for example to print tickets, baggage tags, or product labels for a certain company. Such a program may be initiated by a startup file (autoexec.bat) stored in the printer's permanent memory or in a memory card.

There can be one startup file stored in each of three different parts of the printer's memory. If there are startup files stored in more than one part, only one will be used with the following priority:

1. An autoexec.bat file stored in a memory card, provided the card was inserted in the printer before the power was switched on.
2. An autoexec.bat file stored in the read/write part of the printer's permanent memory (device "/c").
3. The pup.bat file (Intermecc Shell) in the read-only part of the printer's permanent memory (device "/rom").



Note: If you insert a CompactFlash memory card that contains a startup file before you switch on the printer, this startup file will be used instead of Intermecc Shell.

Memory Card

If you want to use a memory card, you must insert it into the slot in the printer's rear plate before you switch on the power. The memory card must be a CompactFlash card (8MB-1GB). CompactFlash cards marked "CF+" will not work. You can use the CompactFlash card to expand the printer's storage memory ("card1:"). There are also three types of preprogrammed CompactFlash cards:

- Font Cards provide additional fonts that can be used as long as the card remains inserted in the printer.
- Font Install Cards permanently install additional fonts in the printer, which can be used even after the card has been removed.
- Firmware Cards automatically replace the printer's firmware, usually with an updated version.

CompactFlash cards are widely used for consumer's computer products like digital cameras. You can get a certain protection from theft by installing an optional plate that covers an inserted CompactFlash card.

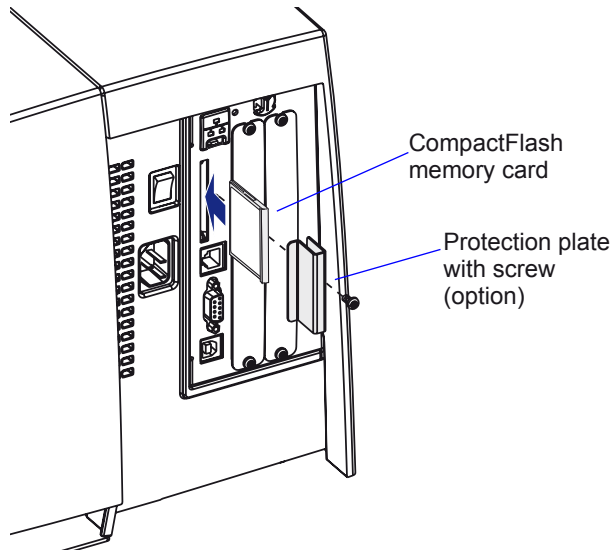

Note: Always switch off the power before inserting or removing a memory card! The card will only fit in one way. A memory card is only detected if it is inserted before the printer is started.

Switching On the Printer

Before switching on the printer, make the necessary connections, insert any memory card you want to use, and check that the printhead is engaged.

Switch on the power using the On/Off switch on the rear plate. The “Power” control lamp on the front panel lights up when the power is on. Wait for a few moments, while the printer loads the program and runs some self-diagnostic tests:

```
Starting
■■■■■■■
```

After a short time, the printer is initialized. The progress of the initialization is indicated by an increasing number of colons on the lower line in the display:

```
Initializing
:::
```

The type of startup file running in the printer is indicated by the message shown in the display window immediately after initialization.

A. Intermec Shell Startup Program

```
ENTER=SHELL
5 sec.      v.8.2
 4 sec.      v.8.2
  3 sec.      v.8.2
   2 sec.      v.8.2
    1 sec.      v.8.2
```

Refer to Chapter 8 for more information on Intermec Shell. The digits in the lower right corner of the display indicate the version of Intermec Shell.

B. Custom-Made Application Program

Any other display messages than those illustrated above indicates that the printer is running some custom-made, non-standard application program, or that some error has occurred.



4 Media Load

This chapter explains how to load the printer with media, that is labels, tickets, tag, or strips, for the following modes of operation:

- Tear-Off (straight-through)
- Peel-Off (self-strip), requires optional integral self-strip unit with liner takeup
- Cut-Off (requires optional cutter)
- External supply (fan-folds), fan-fold guide available as option



Note: For information on how to load the printer with RFID media, please refer to the documentation that came with your RFID kit.

Tear-Off (Straight-through)

The EasyCoder PM4i can print on labels, tickets, tags, and continuous stock in various forms. This section describes the case when the media is torn off manually against the printer's tear bar. This method is also known as "straight-through printing."

Use the <Feed> key (see figure #11) when loading the same type of media. When switching to a new type of media, or if the printer does not feed out the media properly, simultaneously press the <Shift> and <Feed> keys to perform a "testfeed."

Tear-off can be used for:

- Non-adhesive continuous stock
- Self-adhesive continuous stock with liner
- Self-adhesive labels with liner
- Tickets with gaps, with or without perforations
- Tickets with black marks, with or without perforations

An optional label taken sensor can hold the printing of the next copy in the batch until the present copy has been removed, see Chapter 9, "Options."

Tear-Off, cont.

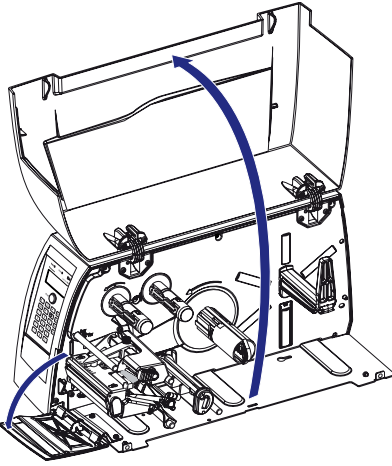
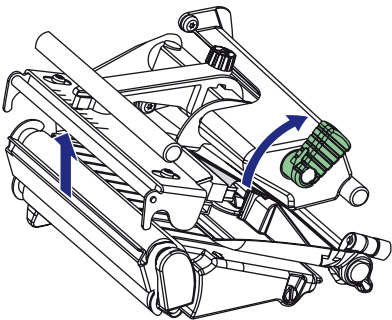
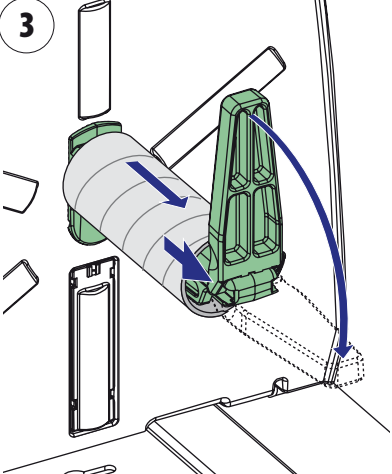
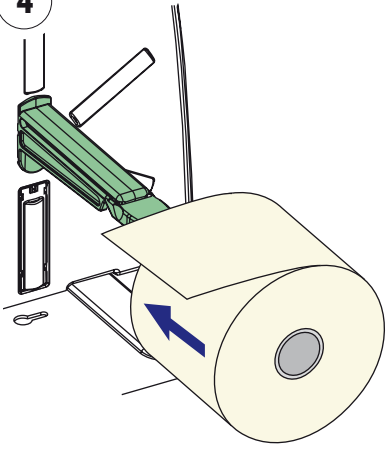
<p>1</p>  <p>Open the front and side doors.</p>	<p>2</p>  <p>Turn the printhead lift lever clockwise to raise the printhead.</p>
<p>3</p>  <p>Pull out the edge guide as far as it goes and fold it down to a horizontal position. Remove any empty core from the media supply roll post.</p>	<p>4</p>  <p>Fit a new roll of media on the supply post. Fold up and adjust the edge guide so the roll becomes flush with the center section.</p>

Tear-Off, cont.

5

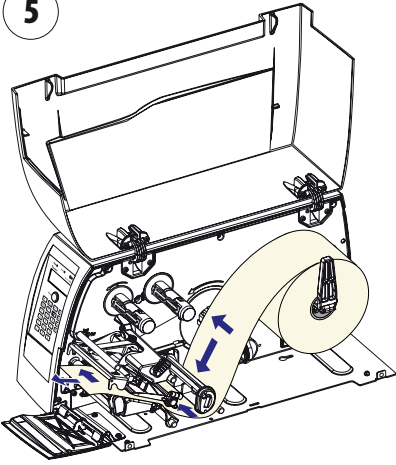

Route the media through the print mechanism and push it towards the center section as far as it goes.

6

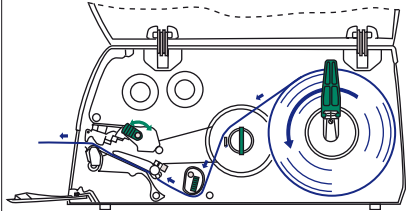

This diagram shows the media path.

7

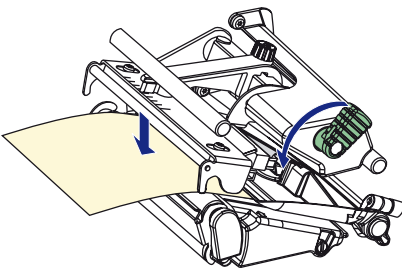

Turn the printhead lift lever counter-clockwise to engage the printhead.

8

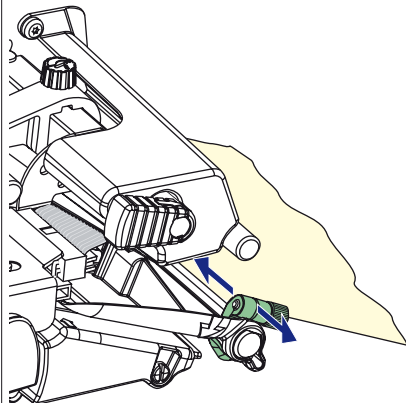

Adjust the position of the green edge guide so the media is guided with a minimum of play. Lock with the nut.

Tear-Off, cont.

9

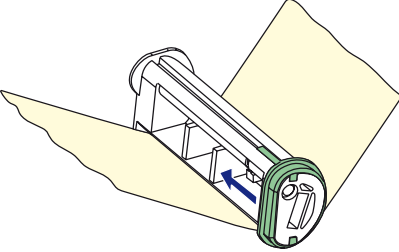

Adjust the position of the edge guide on the label slack absorber according to the width of the media.

Detailed description: This diagram shows a close-up of a mechanical component, the label slack absorber, with a yellow sheet of media being fed through it. A green edge guide is positioned on the right side of the media. A blue double-headed arrow indicates that this guide can be moved horizontally to adjust its position relative to the media's width.

10

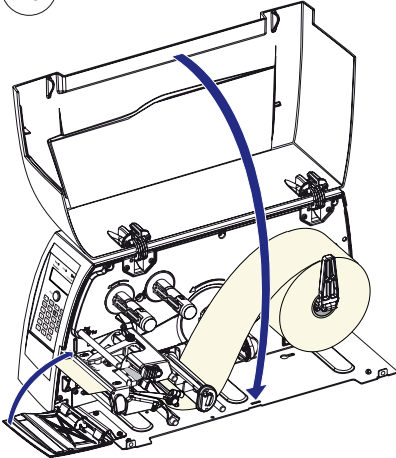

Close the front and side door, making sure that the media runs through the slot in the front door.

Detailed description: This diagram shows the internal media path of the device with the front and side doors open. A yellow sheet of media is shown running from a roll on the right, through various rollers and guides, and exiting through a slot in the front door. Blue arrows indicate the direction of the media path and the movement of the doors being closed.

11

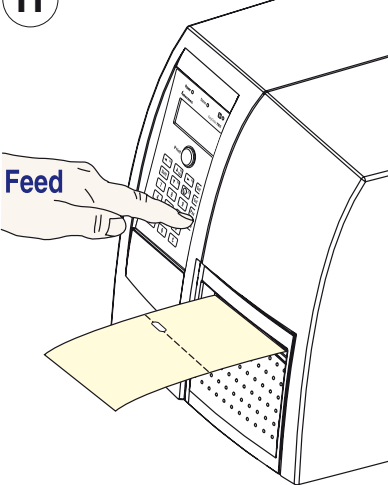

Press the Feed key to advance the media and adjust the media feed. Tear off the media by pulling it downwards.

Detailed description: This diagram shows the front control panel of the device. A hand is shown pressing a key labeled 'Feed'. Below the control panel, a yellow sheet of media is shown partially advanced from the front door. A dashed line on the media indicates the tear-off point.

Peel-Off (Self-strip)

The EasyCoder PM4i can print on labels, tickets, tags, and continuous stock in various forms. This section describes the case when self-adhesive labels are separated from the liner immediately after printing, which requires optional integral self-strip unit with liner takeup. This is also known as “Self-strip” operation.

Peel-off operation cannot be performed with an optional fan-fold guide fitted.

Use the <Feed> key (see figure #14) when loading the same type of media. When switching to a new type of media, or if the printer does not feed out the media properly, simultaneously press the <Shift> and <Feed> keys to perform a “testfeed.”

Peel-off can only be used for:

- Self-adhesive labels with liner

An optional label-taken sensor can hold the printing of the next label in a batch until the present label has been removed, see Chapter 9, “Options.”



Note: Peel-off operation sets high demands on the media in regard of label stiffness, release characteristics of the adhesive and liner, resistance against electrostatic charging etc., so the labels will be dispensed properly. Consult your media supplier or test the media to ascertain that it is suitable for your application.

Peel-Off, cont.

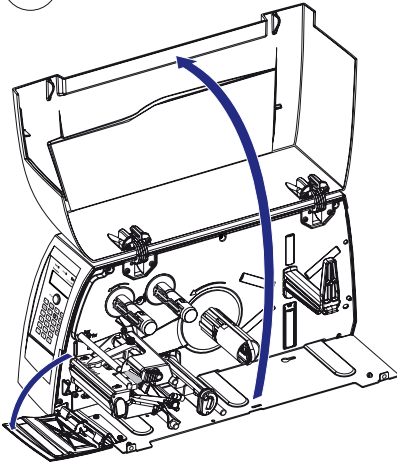
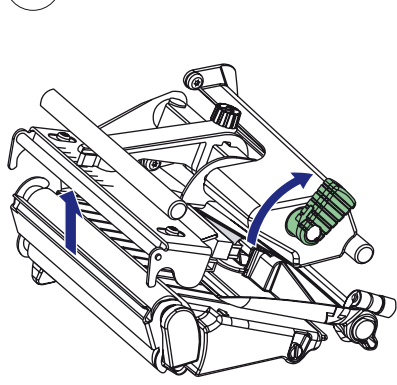
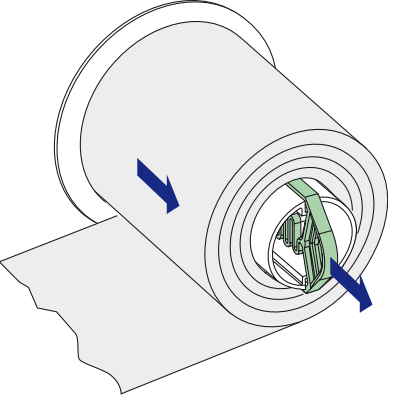
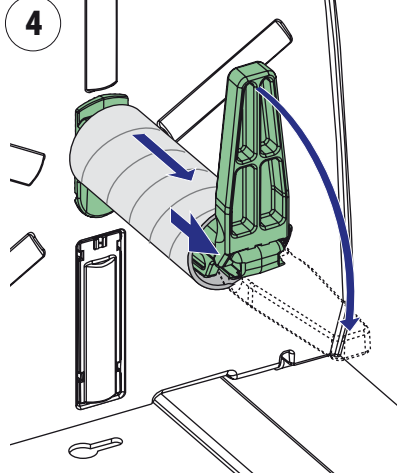
<p>1</p>  <p><i>Open the front and side doors.</i></p>	<p>2</p>  <p><i>Turn the printhead lift lever clockwise to raise the printhead.</i></p>
<p>3</p>  <p><i>Pull out the handle to collapse the takeup hub, then remove any liner.</i></p>	<p>4</p>  <p><i>Pull out the edge guide as far as it goes and fold it down to a horizontal position. Remove any empty core from the media supply roll post.</i></p>

Peel-Off, cont.

5

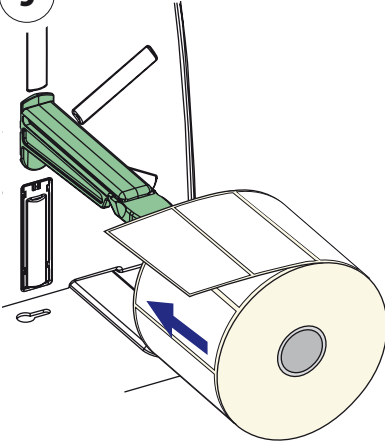

Fit a new roll of media on the supply post. Fold up and adjust the edge guide so the roll becomes flush with the center section.

6

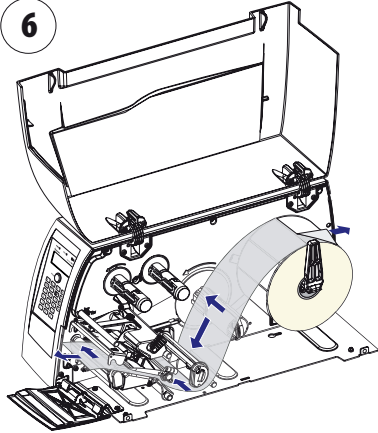

Remove labels from the first 50 cm (20 inches) of the liner. Route the liner through the print mechanism and push it inwards towards the center section as far as it goes.

7

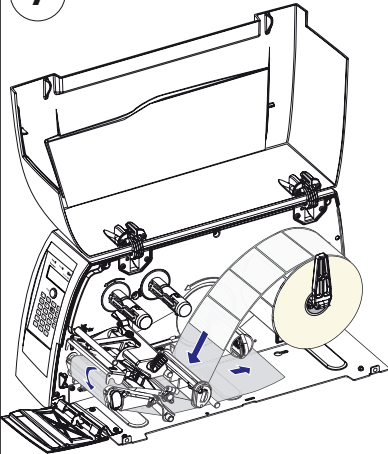

Route the liner around the tear bar and the liner drive roller and back under the print mechanism and guide shafts.

8

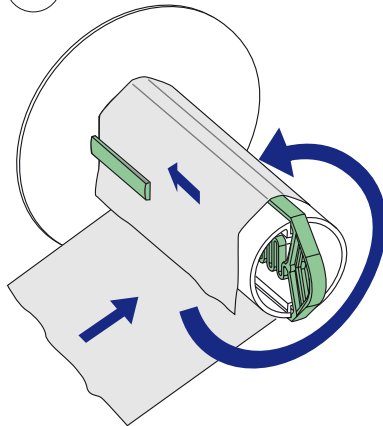

Insert the start of the liner under the lip of the takeup hub, then rotate the hub counterclockwise a few turns to wind up some of the liner.

Peel-Off, cont.

9

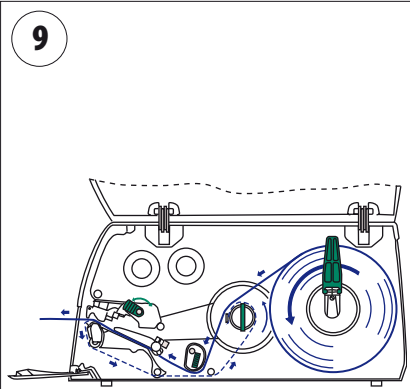

This diagram shows the media and liner paths.

10

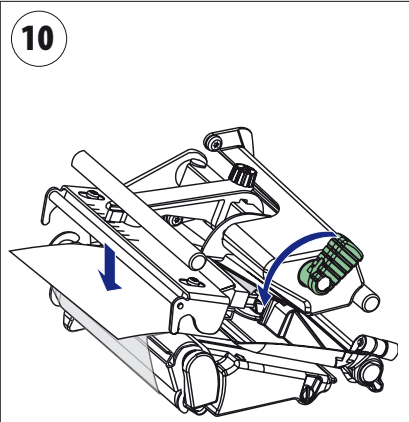

Turn the printhead lift lever counter-clockwise to engage the printhead.

11

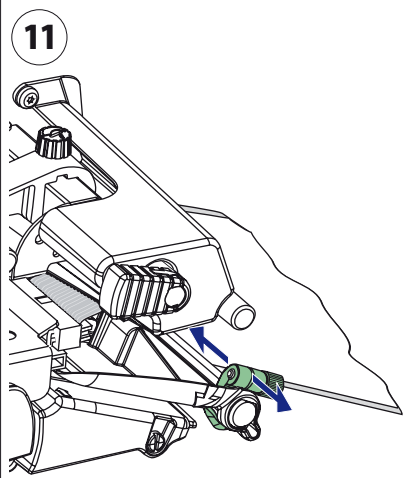

Adjust the position of the green edge guide so the media is guided with a minimum of play. Lock with the nut.

12

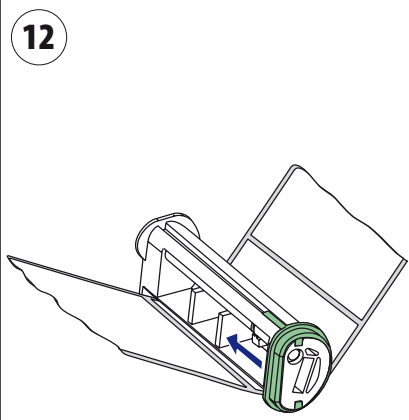

Adjust the position of the edge guide on the label slack absorber according to the width of the media.

Peel-Off, cont.

13

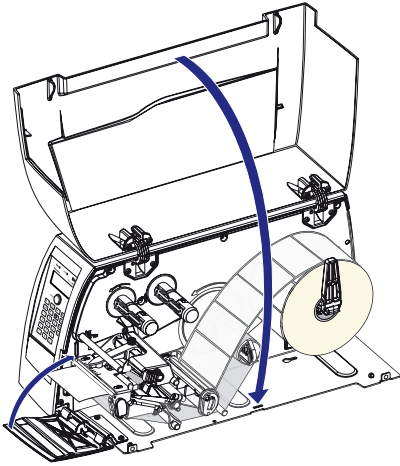

Close the front and side doors.

14

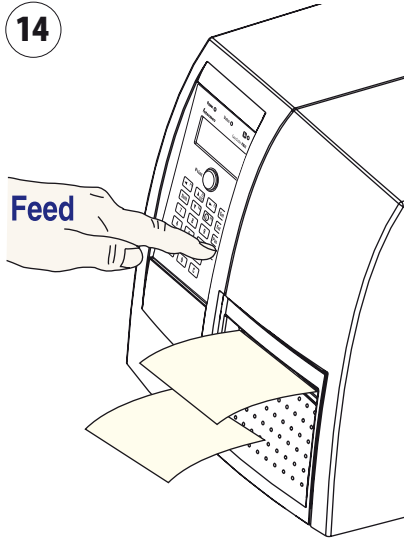

Press the Feed key to advance the media and adjust the media feed.

Cut-Off

The EasyCoder PM4i can print on labels, tickets, tags, and continuous stock in various forms. This section describes the case when the media is cut off by an automatic paper cutter (option).

Use the <Feed> key (see figure #10) when loading the same type of media. When switching to a new type of media or if the printer does not feed out the media properly, simultaneously press the <Shift> and <Feed> keys to perform a “testfeed.”

Cut-off can be used for:

- Non-adhesive continuous stock
- Self-adhesive labels with liner (cut only liner between labels)

The cutter is designed to cut through paper-based media with a thickness between 60 and 175 μm , which roughly corresponds to a paper weight of 60 to 175 grams/ m^2 (basis weight 40 to 120 lb). The cutter should not be used to cut through labels, because the adhesive will stick to the shears, which can damage the cutter.

The cutter is held by a latch inside the media compartment and can be tilted forward to facilitate media load. A switch prevents the cutter from operating when in open position.

The optional label taken sensor cannot be used with the cutter.

There is no front door when a cutter is installed.

The cutter can be fitted with an optional tray for collecting cut-off labels.

Cut-Off, cont.

1

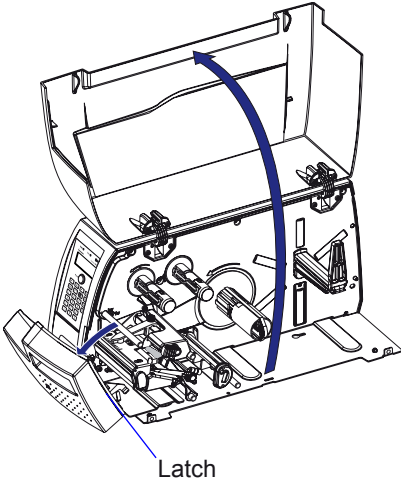

Latch

Open the cutter and the side door.

2

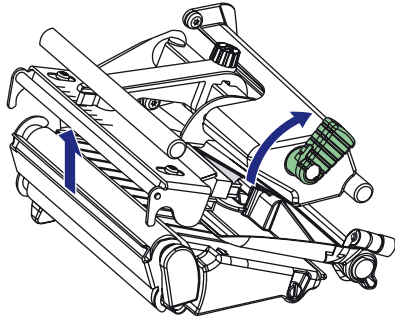

Turn the printhead lift lever clockwise to raise the printhead.

3

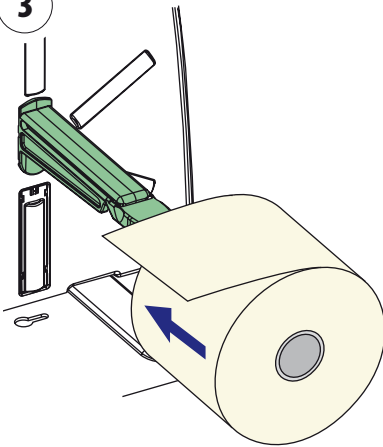

Pull out the edge guide as far as it goes and fold it down to a horizontal position. Remove any empty core from the media supply roll post.

4

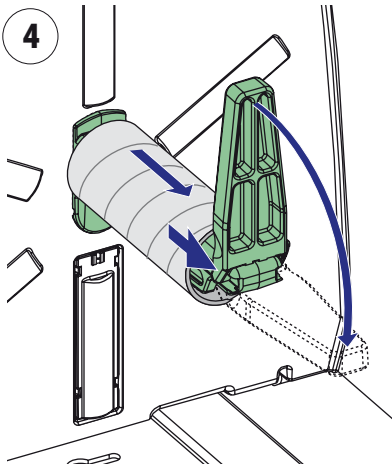

Fit a new roll of media on the supply post. Fold up and adjust the edge guide so the roll becomes flush with the center section.

Cut-Off, cont.

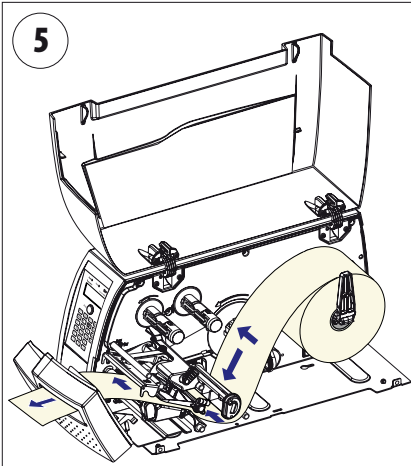

5
Route the media through the print mechanism and cutter. Then push it towards the center section as far as it will go.

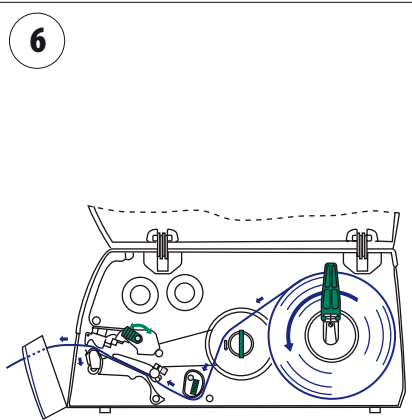

6
This diagram shows the media path.

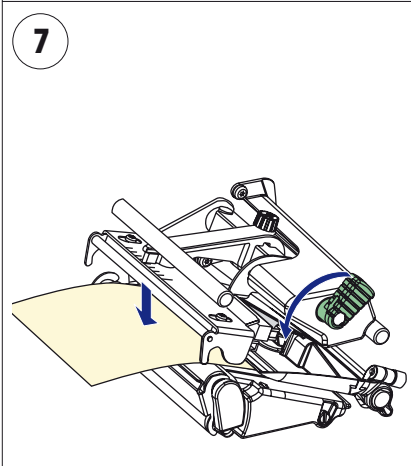

7
Turn the printhead lift lever counter-clockwise to engage the printhead.

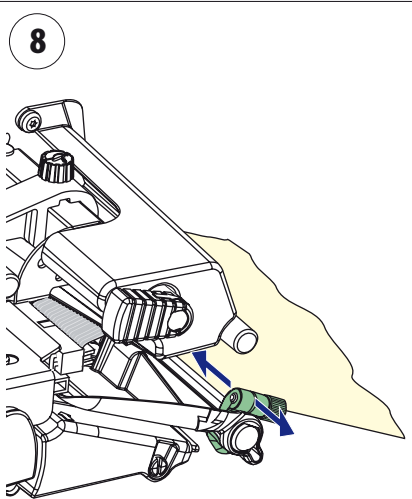

8
Adjust the position of the green edge guide so the media is guided with a minimum of play. Lock with the nut.

Cut-Off, cont.

9

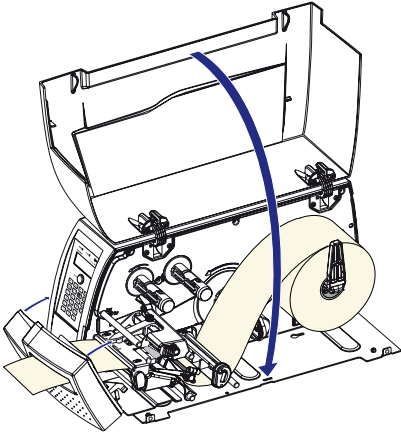

Close the side door and the cutter while pulling the media tight.

10

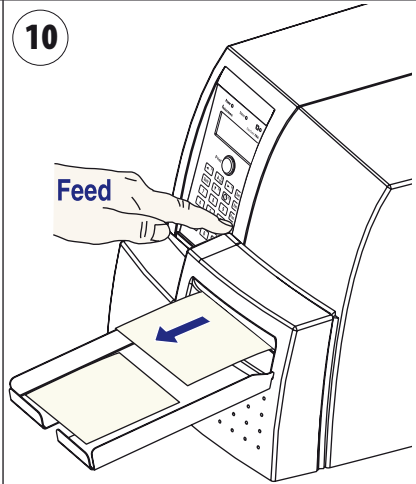

Press the Feed key to advance the media and adjust the media feed. The labels can be collected on an optional tray.

External Supply (Fan-fold)

The EasyCoder PM4i Compact can print on labels, tickets, tags, and continuous stock in various forms. This section describes the case when the media supply is placed behind the printer, usually in the form of fan-folded tickets or tags. External supply can be used with tear-off (straight-through) and cut-off printing.

Although it is possible to simply feed the media through the hole in the rear part of the side door and directly to the print mechanism, we strongly recommend using a printer fitted with a special fan-fold guide as illustrated below. Not only does it make media loading much easier, but it also guides the media with great accuracy. The fan-fold guide can be adjusted for various media widths down to 40 mm (1.57 inches).

When using an external media supply, take care to protect the media from dust, dirt or other foreign particles, that can impair the printout quality or cause unnecessary wear to the printhead.

Depending on brand and quality, all direct thermal media are more or less sensitive to heat, direct sunlight, moisture, oil, plasticizers, fat, and other substances. Protect the media accordingly.

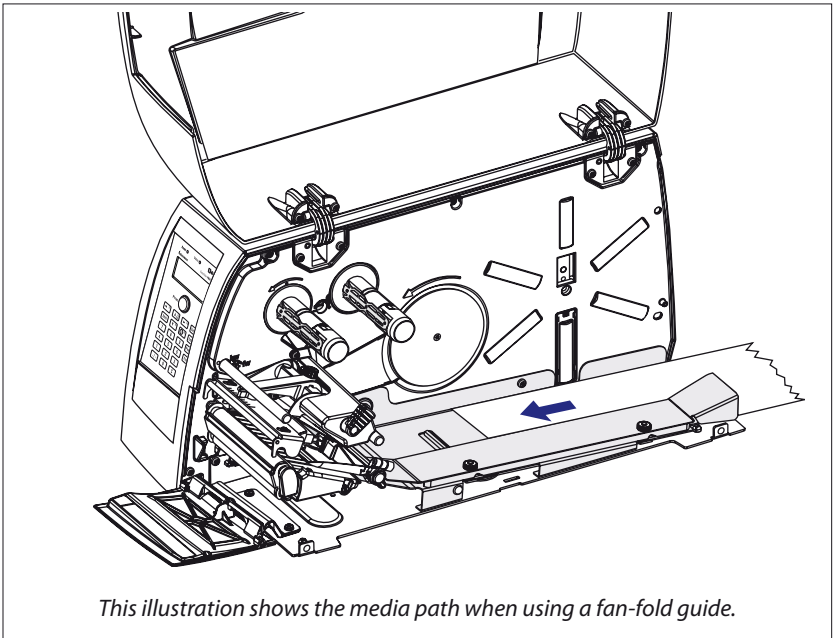

Rotating Media Supply

The EasyCoder PM4i can, as an alternative to the standard media supply roll post, use an optional rotating media supply hub, regardless of tear-off, cut-off, or peel-off operation.

The rotating media supply hub can be supplemented by an adapter for media rolls with a 76 mm (3 inches) core, a media roll retainer which prevents the media roll from uncoiling, and a paper low sensor, that can detect when the remaining supply of media reaches a predetermined level. Also refer to Chapter 6, “Setting Up the Printer” and Chapter 9, “Options.”

Media loading corresponds to the use of a media supply roll post, but the media roll needs to be pressed sideways onto the hub, making sure that it becomes flush with the disc at the inner end of the hub.

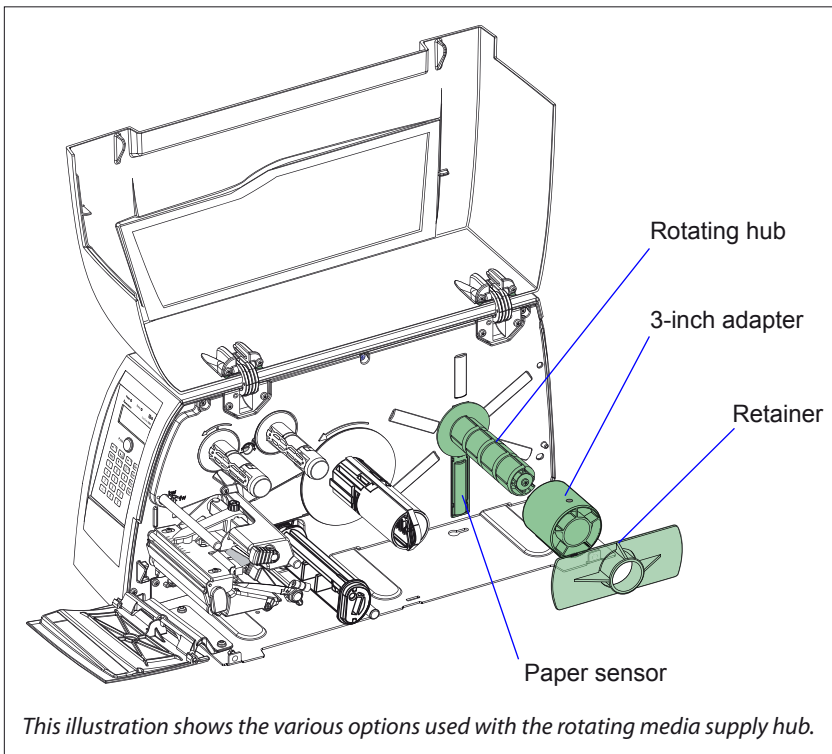



5 Thermal Transfer Printing

This chapter explains how to load the printer with ribbon for thermal transfer printing.

Ribbon Load

The EasyCoder PM4i can print on labels, tickets, tags, and continuous stock using either direct thermal printing on special heat-sensitive media or thermal transfer printing using a special ink-coated ribbon.

Thermal transfer printing makes it possible to use a wide range of receiving face materials and gives a durable printout less vulnerable to fat, chemicals, heat, sunlight etc. than direct thermal printing. Make sure to select a type of ribbon that matches the type of receiving face material and to set up the printer accordingly.

The EasyCoder PM4i can use transfer ribbon rolls wound with the ink-coated side facing either outward or inward. Illustrations in this manual show the ink-coated side facing inward.

Even if ribbon usually is loaded in connection with media replenishment, no loaded media are shown in the illustrations in this chapter in order to give a clearer view of the ribbon path. Refer to Chapter 4 for media load instructions.

Most transfer ribbons do not smear at room temperature.

Ribbon Load, cont.

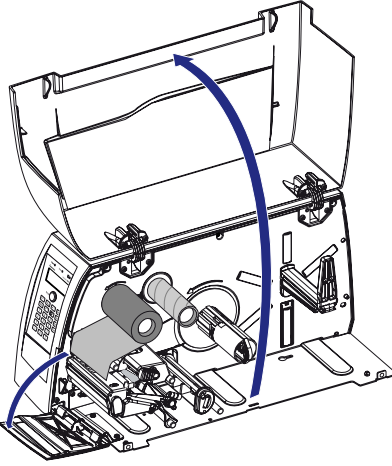
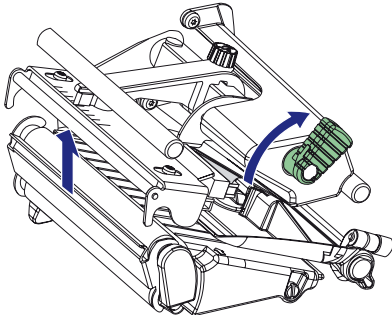
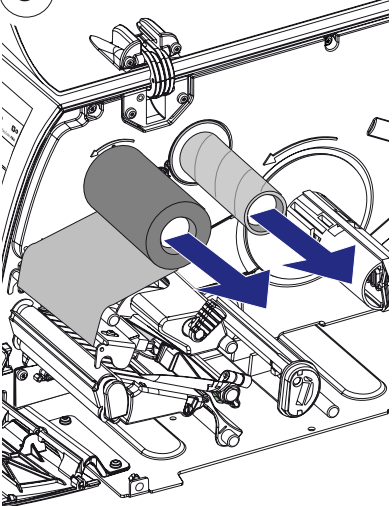
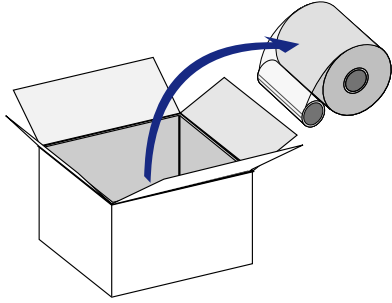
<p>1</p>  <p>Open the front and side doors.</p>	<p>2</p>  <p>Turn the printhead lift lever clockwise to raise the printhead.</p>
<p>3</p>  <p>In case of ribbon reload, remove any used ribbon and empty ribbon core.</p>	<p>4</p>  <p>Unpack a roll of original Intermec thermal transfer ribbon.</p>

Ribbon Load, cont.

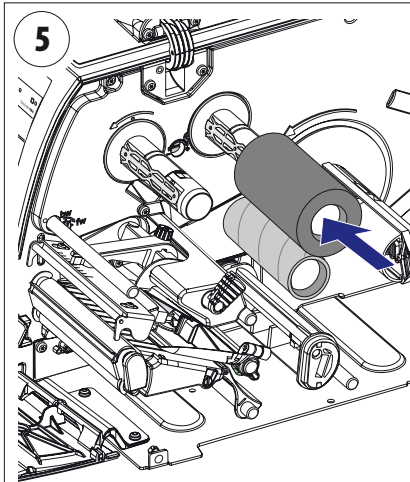

Slide the ribbon roll onto the supply hub so the ink-coated side faces down when the ribbon is routed through the print mechanism.

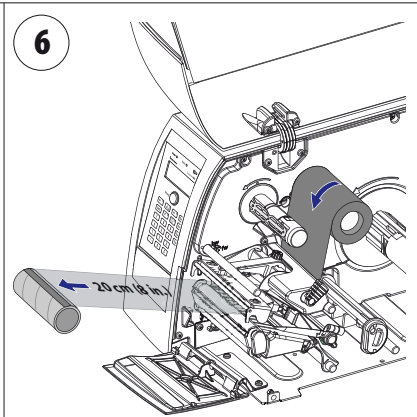

Route the ribbon through the print mechanism underneath the transparent upper LSS guide and pull out approximately 20 cm (8 inches) of ribbon leader.

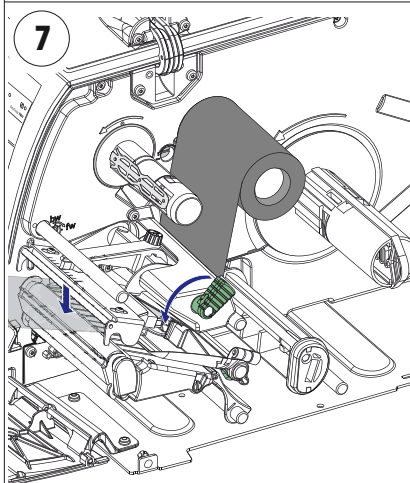

Without releasing the ribbon, turn the printhead lift lever counterclockwise to engage the printhead and lock the ribbon.

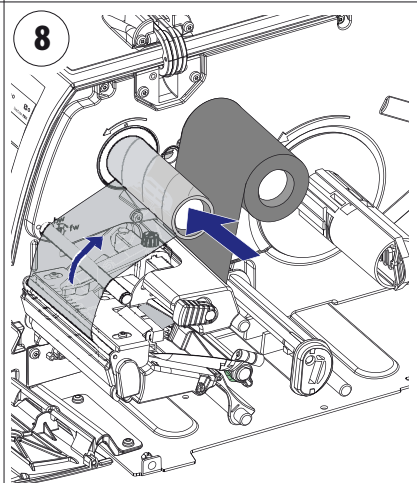

Slide the empty cardboard core onto the ribbon rewind hub so the ribbon is wound up when the hub rotates counterclockwise.

Ribbon Load, cont.

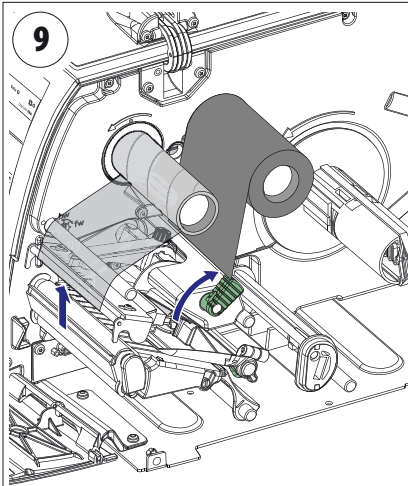

Turn the printhead lift lever clockwise to raise the printhead and release the ribbon.

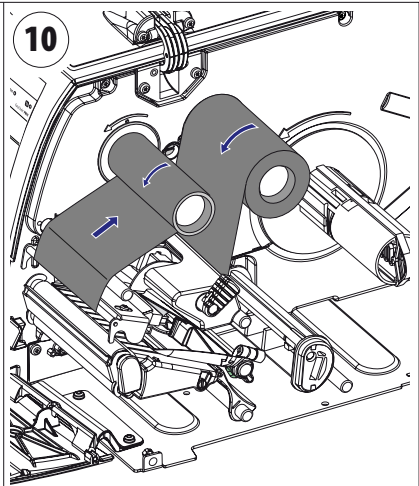

Manually advance the ribbon until all of the transparent leader has passed the printhead and the ribbon becomes tight.

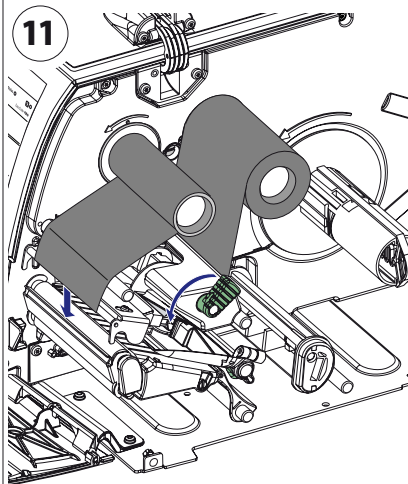

Turn the printhead lift knob counter-clockwise to engage the printhead.

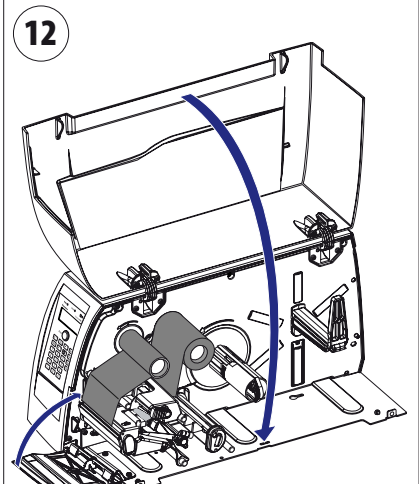

Close the front and side doors.



6 Setting Up the Printer

This chapter describes the various parameters that are used in the Setup Mode (see Chapter 7) or in the various application programs to configure the printer for the user's specific requirements. It covers the following topics:

- Description
- Default setup
- Setup Parameters in regard of communication, feed adjust, media, and print defines.

When measures are specified as “dots”, the actual length in millimeters or inches depends on the printhead density. Convert as follows:

8 dots/mm (203.2 dots/inch) printhead:

1 dots = 0.125 mm = 0.0049 inches (4.9 mils)

11.81 dots/mm (300 dots/inch) printhead:

1 dot = 0.085 mm = 0.0033 inches (3.3 mils)

Description

The setup controls the printer in regard of serial communication, media feed, and print speed, and specifies which type of media and (optionally) ribbon is loaded in the printer.

Check the list of the printer's default setup parameters on the next page to see if they match your requirements. If not, you will have to change the setup using one of the methods described below. The setup may also be changed by Intermec PrintSet, InterDriver, and LabelShop, or third-party application programs.

Setup Mode

- Press the <Setup> key on the printer's built-in keyboard to enter the Setup Mode, or
- select the Setup option in Intermec Shell to enter the Setup Mode, or
- execute the Intermec Fingerprint **SETUP** instruction to enter the Setup Mode, or
- access the Setup Mode via the printer's home (requires an optional EasyLAN interface board).

See Chapter 7, "Setup Mode" in this manual and the EasyLAN documentation.

Intermec Fingerprint

- Use **setup strings** to change individual setup parameters remotely from the host, or
- use **setup files** to create sets of setup parameters remotely from the host.

See the *Intermec Fingerprint v8.xx* manuals.

Intermec Direct Protocol

- Use **setup strings** to change individual setup parameters remotely from the host.

See the *Intermec Direct Protocol v8.xx* manuals.

Default Setup

The printer's default setup is listed below (assuming no options installed):

Ser-Com "uart1:"	
Baud rate	9600 bps
Character length	8 bits
Parity	None
Stop bits	1 bit
RTS/CTS	Disable
ENQ/ACK	Disable
XON/XOFF, data to host	Disable
XON/XOFF, data from host	Disable
New line	CR/LF
Receive buffer	1024 bytes
Transmit buffer	1024 bytes
Feedadjust:	
Startadjust	0 dots
Stopadjust	0 dots
Media:	
X-start (8 dots/mm = 203.2 dpi)	24 dots
X-start (11.81 dots/mm = 300 dpi)	36 dots
Width (8 dots/mm = 203.2 dpi)	832 dots
Width (11.81 dots/mm = 300 dpi)	1248 dots
Length (8 dots/mm = 203.2 dpi)	1200 dots
Length (11.81 dots/mm = 300 dpi)	1800 dots
Media type	Label (w Gaps)
Paper type	Thermal transfer
Ribbon constant	90
Ribbon factor	25
Label offset	0
Low diameter (ribbon)	0 dots
Contrast	±0%
Print Defines:	
Print speed	100 mm/sec.

Reading the Current Setup

The printer's current setup values can be read from the printer's display window by browsing through the Setup Mode.

You can list the printer's current setup values by printing test label "Setup Info" in the Setup Mode or by using Intermec Shell.

The current setup values can be sent to the host via the standard serial communication channel using a **SETUP WRITE "uart1:"** statement (see *Intermec Fingerprint v8.xx, Programmer's Reference Manual*).

Setup Parameters

Serial Communication

The serial communication parameters control the communication between the printer and the connected computer or other devices on the standard serial port "uart1:" and the optional serial ports "uart2:", "uart3:", "uart4:", and "uart5:". The optional ports require one or two optional interface boards. The printer's firmware detects if an interface board is installed in the printer and presents additional sets of communication setup menus depending on type of communication (refer to Chapter 7, "Setup Mode" and the overviews depicted in Appendix E).



Note: The serial communication parameters have no effect on parallel or EasyLAN communications, or on the IN and OUT ports on the optional Interface Board.

For the serial communication channel "uart1:", the following parameters can be set. Make sure they match the setup of the connected device or vice versa. If the setup of the printer and the setup of the host do not match, the response from the printer to host will be garbled.

Baud Rate

The baud rate is the transmission speed in bits per second. There are 10 options:

- 300
- 600
- 1200
- 2400
- 4800
- 9600 (default)
- 19200
- 38400
- 57600
- 115200

Character Length

The character length specifies the number of bits that will define a character. Eight bits are recommended, because that option allows more special characters and characters specific for foreign languages to be used. Refer to the *Intermec Fingerprint v8.xx, Programmer's Reference Manual* for more information.

- 7 Characters ASCII 000 to 127 decimal
- 8 Characters ASCII 000 to 255 decimal (default)

Parity

The parity decides how the firmware will check for transmission errors. There are five options:

- None (default)
- Even
- Odd
- Mark
- Space

Stop Bits

The number of stop bits specifies how many bits will define the end of a character. There are two options:

- 1 (default)
- 2

Flow Control

RTS/CTS is a protocol where the communication is controlled by currents through separate lines in the cable being set either to high or low. This option is disabled by default.

RTS high indicates that the transmitting unit is able to receive characters. RTS low indicates that the receive buffer is filled to 75% (see XON/XOFF).

CTS high indicates that the unit transmitting the CTS signal is ready to receive data. CTS low indicates that the receive buffer is full (see XON/XOFF). In some computer programs, for example MS Windows Terminal, RTS/CTS is designated “Hardware.”

ENQ/ACK is a protocol where the communication is controlled by the control characters ENQ (ASCII 05 dec.) and ACK (ASCII 06 dec.) being transmitted on the same line as the data. The sending unit transmits ENQ at regular intervals. If the response ACK is not received, the

transmission is held up awaiting an ACK character from the receiving unit. By default, ENQ/ACK is disabled.

XON/XOFF is a protocol where the communication is controlled by the control characters XON (ASCII 17 dec.) and XOFF (ASCII 19 dec.) being transmitted on the same line as the data. XON/XOFF can be enabled/disabled separately for data received from the host by the printer (printer sends XON/XOFF) and for data transmitted to the host from the printer (host sends XON/XOFF).

XOFF is sent from the printer when its receive buffer is filled to 75%, and the transmission from the host is held, waiting for an XON character. When enough data have been processed so the receive buffer is filled only to 50%, the printer sends an XON character and the host resumes transmitting data. The same principles apply to XON/XOFF sent by the host, even if the percentage figure may differ. By default, XON/XOFF is disabled for data in both directions.

New Line

Selects the character(s) transmitted from the printer to specify the switching to a new line. There are three options:

- CR/LF ASCII 13 + 10 dec. (default)
- LF ASCII 10 dec.
- CR ASCII 13 dec.

Receive Buffer

The receive buffer stores the input data before processing. Default size is 1024 bytes.

Transmit Buffer

The transmit buffer stores the output data to be transmitted before transmission. Default size is 1024 bytes.

Feedadjust

The Feedadjust part of the Setup Mode controls how much of the media is fed out or pulled back before and/or after the actual printing. These settings are global and will be effected regardless of which program is run.



Note: The firmware uses the front edges of labels w. gaps, the ends of detection slots, and the forward edges of black marks for detection, all seen in relation to the feed direction.

Start Adjust

The Start Adjust value is given as a positive or negative number of dots. Default value is 0, which places the origin a certain distance back from the forward edge of the copy.

- A **positive** start adjustment means that the specified length of media will be fed out before the printing starts. Thus, the origin is moved further back from the forward edge of the copy.
- A **negative** start adjustment means that the specified length of media will be pulled back before the printing starts. Thus, the origin is moved towards the forward edge of the copy.

Stop Adjust

The Stop Adjust value is given as a positive or negative number of dots. Default value is 0, which stops the media feed in a position suitable for tear off operation.

- A **positive** stop adjustment means that the normal media feed after the printing is completed will be increased by the specified value.
- A **negative** stop adjustment means that the normal media feed after the printing is completed will be decreased by the specified value.

Recommended Feed Adjustments

The following settings allow printing from the top of the label. Minor deviations from the recommended values may be required due to various combinations of media types, roll size, type of media supply device, and individual differences between printers.

Adjustment type	8 dots/mm 203.2 dpi (std)	11.81 dots/mm 300 dpi (option)	Distance in mm	Distance in inches
Tear-Off (Straight-through)				
Start adjust:	-100 dots	-148 dots	12.5	0.49
Stop adjust:	0 dots	0 dots	0	0
Peel-Off (Self-strip)				
Start adjust:	-56 dots	-83 dots	7	0.28
Stop adjust:	-44 dots	-65 dots	5.5	0.22
Cut between labels w. gaps				
Start adjust:	-325 dots	-480 dots	40.6	1.6
Stop adjust:	+240 dots	+354 dots	30.0	1.18
Cut fix and variable length strip				
Start adjust:	-340 dots	-502 dots	42.5	1.67
Stop adjust:	+340 dots	+502 dots	42.5	1.67

Media

The media parameters tell the firmware the characteristics of the media that will be used, so the printout will be positioned correctly and get the best quality possible.

Media Size

The size of the printable area is defined by three parameters; X-Start, Width, and Length.

X-Start

Specifies the position of the origin along the dots on the printhead.

The default X-start value prevents printing outside labels when the liner is slightly wider than the labels. If you want to maximize the print width, reset the X-start value to 0.

By increasing the value for the X-start parameter, the origin will be moved outwards, away from the inner edge of the media path. In other words, the larger X-start value, the wider inner margin and the less available print width.

Width

Specifies the width of the printable area in number of dots from the origin. Thus, the sum of the X-start and width values gives the outer margin of the printable area. The width should be set to prevent printing outside the media, which may harm the printhead.

Length

Specifies the length of the printable area in number of dots from the origin along the Y-coordinate and allocates memory space for two identical image buffers in the printer's temporary memory.

The size of each buffer can be calculated using this formula:

Buffer size (bits) = [Print length in dots] x [Printhead width in dots]



Note: The temporary memory has other functions that also require some memory space. To obtain a longer print area, the memory can be increased by fitting a larger SDRAM SIMM on the printer's CPU board as described in the Service Manual.

- The length setup also decides the amount of media feed when using “fix length strip.”

- The length setup creates an emergency stop, which works when the printer is set up for “Label (w gaps)”, “Ticket (w mark)”, or “Ticket (w gaps).” If the label stop sensor has not detected a gap or mark within 150% of the set length, the media feed is automatically stopped to avoid feeding out a whole roll of media, because of a sensor malfunction.

By setting up the X-start, the Width, and the Length, you will create a print window inside which the printing can be performed. Any object or field extending outside the print window in any direction will either be clipped or cause an error condition (Error 1003 “Field out of label”), see *Intermec Fingerprint v8.xx, Programmer’s Reference Manual*.

Print Window (8 dots/mm standard printhead)

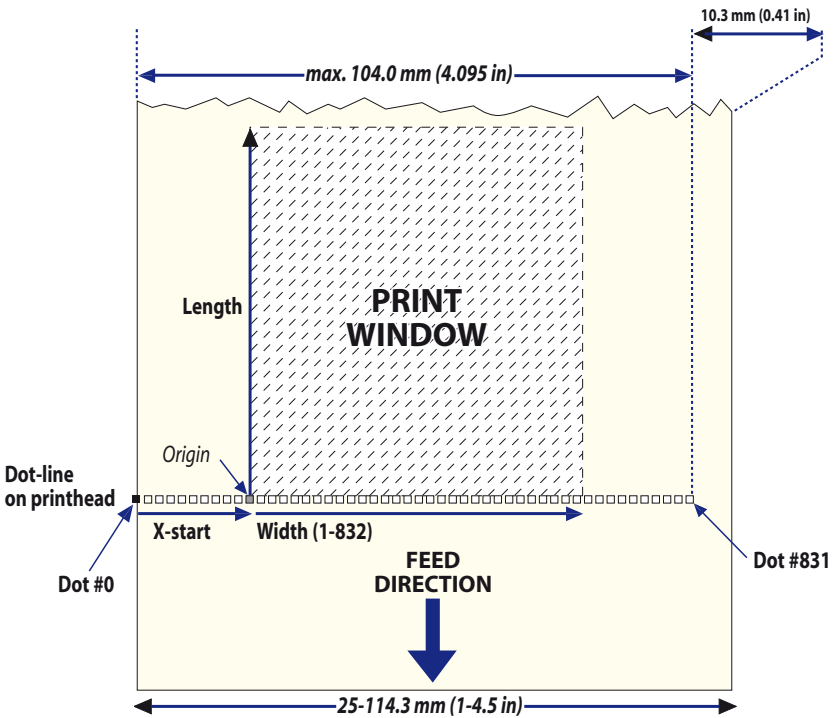

Intermec offers a number of non-standard thermal printheads for the EasyCoder PM4i, see Chapter 9.

Media Type

The Media Type parameters control how the label stop sensor (LSS) and the media feed work. There are five media type options:

- **Label (w gaps)** is used for adhesive labels mounted on liner.
- **Ticket (w mark)** is used for labels, tickets, or continuous stock provided with black marks at the back.
- **Ticket (w gaps)** is used for tickets and tags with detection slits.
- **Fix length strip** is used for continuous stock where the length of the print window decides the length of media to be fed out.
- **Var length strip** is used for continuous stock. The size of the print images decides the length of each copy.

It is important to select the correct media type, so the printer can indicate the following errors.

- Error 1005 “Out of paper” indicates that the last ordered copy could not be printed because of an empty media stock.
- Error 1031 “Next label not found” indicates that the last ordered label or ticket was successfully printed, but no more labels/tickets can be printed because of an empty media stock.

Paper Type

The Paper Type parameters control the heat emitted from the printhead to the direct thermal media or, optionally, the transfer ribbon in order to produce the dots that make up the printout image.

Labels, tickets, tags, strip, and ribbons for various types of application are available from Intermec. For the best printout quality and maximum life of the printhead, use Intermec supplies. Setup recommendations for Intermec supplies offered in Europe and North America are listed in Appendix D.

As a general rule, high energy and/or high print speed will shorten the life of the printhead. Never use higher paper type and print speed settings than necessary for obtaining an acceptable printout quality and throughput speed.

If the ambient temperature is lower than +15°C (+59°F), decrease the print speed by 50 mm/sec.

Start by choosing between two alternatives:

- Direct Thermal printing (option)
- Thermal Transfer printing (default)

Your choice will decide which parameters to enter next:

Direct Thermal Printing

- Label Constant (range 50 to 115)
- Label Factor (range 10 to 50)

When adjusting the image darkness for non-Intermec direct thermal media, set the Label Factor to the recommended value for the type of direct thermal media. Set the Label Constant to the value listed below and decrease or increase it for lighter or darker images respectively until you are satisfied with the printout quality.

General Paper Type Settings Guide (Direct Thermal)

Sensitivity ¹	Label Constant	Label Factor	Max Print Speed	
			8 dots/mm	11.81 dots/mm
Low	100	40	100	100
Standard	90	40	125	125
High	80	40	175	150
Ultra high	60	40	200	150

^{1/}. Note that preprint and varnish decrease the sensitivity of direct thermal media.

Thermal Transfer Printing

- Ribbon Constant (range 50 to 115)
- Ribbon Factor (range 10 to 50)
- Label Offset (range -50 to 50)
- Ribbon Sensor (autoadjustment)
- Low Diameter (range 25 to 80 mm)

When adjusting the image darkness for non-Intermec media and transfer ribbons, set the Ribbon Factor to the recommended value for the type of thermal transfer ribbon. Set the Ribbon Constant at the value listed below and decrease or increase it for lighter or darker images respectively until you are satisfied with the printout quality. The Label Offset parameter is presently not used, so keep it at the default value 0.

General Paper Type Settings Guide (Thermal Transfer)

Type	Ribbon Constant	Ribbon Factor	Max Print Speed	
			8 dots/mm	11.81 dots/mm
Wax (Europe)	80	25	150	125
Wax (U.S.A.)	65	25	150	125
Wax/Resin (Europe)	90	25	150-200	125-150
Wax/Resin (U.S.A.)	75	25	150-200	125-150
Resin (Europe)	100	30	200	150
Resin (U.S.A.)	90	30	200	150

The Ribbon Sensor parameter is read-only. When performing a Testfeed or when pressing the <Enter> key when the Ribbon Sensor menu is displayed, the printer will feed out some media and autoadjust the sensor. The resulting setting is displayed in the menu.

The Low Diameter parameter specifies the diameter of the ribbon supply roll, where SYSVAR(26) switches from 0 to 1. SYSVAR(26) = 0 means that there is still a sufficient supply of ribbon, whereas SYSVAR(26) = 1 means that it is time to consider replacing the ribbon supply. The diameter is expressed in millimeters (1 mm = 0.04 in.) and an accuracy of ±3 mm can be expected. Note that this setting has little effect unless SYSVAR(26) is read by a Fingerprint program. However, Error 1083 “Ribbon Low” is reported at every tenth printing operation. By default, the low diameter is 0, that is, the ribbon low function is disabled.

Contrast

Use the contrast parameter to make minor adjustments of the blackness in the printout, for example to adapt the printer to variations in quality between different batches of the same media. 11 options are displayed in an endless loop from -10% to +10%. Default value is 0%. The contrast is reset to the default (± 0) whenever a new paper type is specified, regardless which method has been used.

Paper Sensor

The Paper Sensor parameter is read-only. By pressing the <Enter> key, the optional media low sensor is automatically adjusted.

The Low Diameter parameter specifies the diameter of the media supply roll, where SYSVAR(46) switches from 0 to 1. SYSVAR(46) = 0 means that there is still a sufficient supply of media, whereas SYSVAR(46) = 1 initiates error 1084 “Paper low”. The diameter is expressed in millimeters (1 mm = 0.04 in.). Default value is 0 (mm) and the maximum value is 200 (mm).

Testfeed

The sensitivity of the label stop sensor (LSS) may need to be adjusted when switching from one type of media to another. This is especially the case when using adhesive labels since the transparency of the liner (backing paper) may vary. When the Testfeed menu is displayed, press the <Enter> key. A number of blank copies will be fed out until the firmware has decided the proper setting for the LSS. At the same time, the front edges of the labels, tickets, etc. are detected so the feed control can position the media according to the Feedadjust parameter (same as the Intermec Fingerprint statement TESTFEED). Four values used for troubleshooting the LSS are displayed (read-only information).

Print Defines

Head Resistance

The printhead resistance is measured automatically at startup (read-only information).

Testprint

If the printer is equipped with an RFID kit and loaded with RFID media, executing the “RFID Test Label” command will cause the printer to print the tag type name on the label. The test labels “Diamonds”, “Chess”, “Bar Codes #1”, and “Bar Codes #2” are used to check the printout quality and facilitate adjustment of the printhead pressure, see Chapter 12. The test labels “Setup Info” and “Hardware Info” list the printer’s current setup and the installed electronic devices. Test label “Network Info” is only printed if the printer has an optional EasyLAN interface board. If the information does not fit on one label, two or more labels will be printed. If the printer refuses to print a test label, press the <i> key to find out what is wrong, for example “printhead lifted” or “out-of paper”.

Print Speed

The print speed is variable between 100 and 200 mm/sec. for printers fitted with an 8 dots/mm (203.2 dpi) printhead and between 100 and 150 mm/sec. for printers with an optional 11.81 dots/mm (300 dpi) printhead. Generally, the lower the speed, the better the printout quality. This is especially true when printing bar codes with the bars running across the media path (“ladder style”), when printing on demanding face materials, and when printing at low ambient temperatures. The default setting is 100 mm/sec. (approx. 4 inches/sec.).

LSS Test

The function on the label stop sensor (LSS) can be tested automatically or manually as described in Chapter 12 “Adjustments.”

LTS (Label Taken Sensor)

The sensitivity of the LTS can be tested and adjusted as described in Chapter 12 “Adjustments.”

Returning to Factory Default Setup

There are two ways to return to the factory default setup of the printer:

- A** Insert a special CompactFlash memory card and restart the printer.
- B** Using the printer's built-in keyboard.

To reset the printer using the keyboard, do like this:

- 1 Lift the printhead.
- 2 Switch on the power to the printer and press the <i>/F5</i> key and wait until the printer beeps.
- 3 Swiftly press the following keys:
<▼/F4> → <▲/F2> → <▲/F2> → <◀/F1>
- 4 The following message will be displayed:

Factory Default?
Enter=Yes ESC=No

- 5 Within 10 seconds, press <Enter> to reset the printer to factory default. The parameters will be reset and the printer will continue the normal startup.

If you press <Esc/F2> or wait until the 10 seconds timeout has passed, the normal startup will continue without any reset being performed.



Note: If any of the files "card:NOSHELL.CFG", "rom:NOSHELL.CFG", or "c:NOSHELL.CFG" exists in the printer's memory, no reset to factory default will be performed.

The factory default will remove all files used to store settings. It will not reset settings that already has been read when the files are removed. This means that EasyLAN Wireless settings (SSID, keys, etc.) will retain their values from the previous start. However, the next reboot will reset them to factory default.



7 Setup Mode

This chapter describes how to enter the setup mode at installation and how to navigate the setup mode.

Entering Setup Mode at Installation

The method of entering the Setup Mode depends on which startup files are stored in the printer's memory, a subject that was more thoroughly discussed in Chapter 3, "Starting Up."

EasyCoder PM4i with Intermecc Shell

- Switch on the power.
- When the display shows the message "Enter=Shell; x sec...", press <Enter>.
- Press <Setup> (this facility can be used anywhere within Intermecc Shell).
- Set up the printer as described in this chapter.
- Return to Intermecc Shell by pressing <Setup>.

EasyCoder PM4i with a custom-made application program

- Normally, there is no need to enter the Setup Mode for custom-made application programs. Necessary provisions for changing the setup, manually or automatically, should be provided by the program.

Navigating in Setup Mode

While going through the setup procedure, you are guided by texts in the printer's display window. You can navigate between setup menus, acknowledge displayed values, select or type new values, etc. by using the keys on the printer's keyboard.



Note: An external keyboard cannot be used inside the Setup Mode.

	Move one menu to the left on the same level or scroll back in a stack of options ¹ .
	Move up one level ¹ .
	Move one menu to the right on the same level or scroll forward in a stack of options ¹ .
	Move down one level ¹ .
	Display error messages at test label printing failure.
-	Enter numeric values.
	Specify negative values (leading position).
	Clear displayed values.
	Acknowledge and move to next menu or perform testfeeds in the Testfeed menu, or print test labels in the Test label menu.
	Exit the Setup Mode. Can be used anywhere in Setup Mode.

¹/. "Left", "right", "up", and "down" refer to the overviews later in this chapter.

Chapter 7—Setup Mode

The Setup Mode is organized as an endless loop, from which you can select a number of sub-categories. At startup, the firmware determines if options such as a label taken sensor, a cutter, or an interface board is installed in the printer. Only installed options are shown in the Setup Mode.

The diagram below shows the options in the main loop. Detailed overviews are provided in Appendix E.

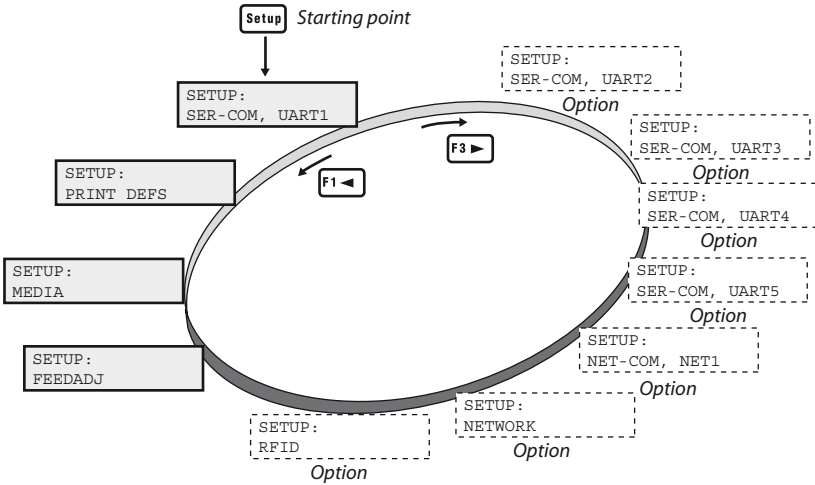



8 Intermec Shell Startup Program

This chapter describes the Intermec Shell startup program and covers the following topics:

- Introduction
- Starting with Intermec Shell
- Intermec Shell Overview
- Line Analyzer

Introduction

Intermec Shell is a startup program, which is a program that automatically starts running when the printer is switched on. Intermec Shell helps the operator to choose between a number of standard or custom-made application programs and to start certain useful facilities, as listed below.

Application Programs

- Intermec Fingerprint (for creating your own programs or to run the Intermec InterDriver)
- Intermec Direct Protocol (easy-to-use slave protocol)
- LINE_AXP.PRG (line analyzer program)
- Other application programs in the printer's memory.

A prerequisite for a program to appear as an option in Intermec Shell is that the program is provided with the extension “.PRG” and is stored in the root of the directory “/c” or “card1:”. However, some original Intermec utility programs are excluded as long as they remain stored in “/rom”:

- ERRHAND.PRG
- FILELIST.PRG
- LBSHTXT.PRG
- MKAUTO.PRG
- SHELLXP.PRG
- WINXP.PRG

Other Facilities

- Setup Mode (manual setup from printer's keyboard)
- Print Setup (printing setup on label)
- Testfeed (formfeeds and auto-adjust of the LSS)
- Test Label (printing of test labels)
- Default setup (resetting all setup parameters to default)
- Software Update (downloading data from a host to a CompactFlash card in the printer, upgrading the printer's firmware from a CompactFlash card, or upgrading the printer's firmware from a file in a PC)
- Reboot (restarting the printer)



Note: Intermec Shell is factory-installed in the printer's permanent memory (device `"/rom"`). If you insert a memory card with another startup file before you switch on the printer, or if there is a startup file stored in the printer's permanent memory (device `"/c"`), this startup file will be used instead of Intermec Shell (see Chapter 3, "Startup Files").

Starting with Intermec Shell

A few seconds after you have switched on the power to the printer and the initialization is completed, the countdown menu of the Intermec Shell program will be displayed:

```
ENTER=SHELL
5 sec.      v.8.2
```

Now you have 5 seconds to enter Intermec Shell by pressing <Enter>.

The lower line tells you how much time you have left. Should the time run out before you have taken any action, the last selected application in Intermec Shell will be opened. If you use the same application all the time, you will only need to switch on the power, once the application has been selected.

If no other application has yet been selected, the current version of Intermec Fingerprint will be opened with "auto" selected as std I/O channel (see Intermec Fingerprint manuals). When the countdown is completed, you will see these lines in the display:

```
Fingerprint
8.70
```

If you want to select another application, just cycle the power and enter Intermec Shell before the countdown is completed.

When you enter the Intermec Shell from the countdown menus, the Select Application menu will be displayed:

```
SHELL
SEL. APPLICATION
```

In this menu, you can choose between two options:

- Press <Enter> to go to menus where you can select an application program.
- Press <▶> to go to the Facilities part of Intermec Shell.

Selecting an Application

In Intermec Shell, the menus present the options in infinite loops, To see all menus and options, refer to the overview in this chapter. The Select application lets you choose an application program that resides in the printer's memory:

- **Current appl.** starts the last selected application (by default Intermec Fingerprint with "auto" selected as standard I/O channel).
- **Fingerprint** is used to create, modify, or run programs written in the Intermec Fingerprint programming language and to run the Intermec InterDriver. This option requires that you also select a standard IN/OUT channel, which is the channel you want to use for communication between the printer and the computer. Normally, you select "uart1:". Refer to the Intermec Fingerprint manuals.
- **Direct Protocol** is an easy-to-use printer protocol for downloading label formats and variable input data to a printer from a host computer. This option requires that you also select a standard IN/OUT channel, that is the serial channel you want to use for communication between the printer and the host. Normally, you select "uart1:". Refer to the *Intermec Direct Protocol v8.xx, Programmer's Reference Manual*.
- **LINE-AXP.PRG** (Line Analyzer) is a Fingerprint program that captures characters received by the printer on a communication channel and prints them on labels. (See later in this chapter.)
- Other Application Programs will presented as additional options.



Note: When an application program is started, it may automatically change the communication setup. If another application is selected later, this communication setup will remain valid, unless the new application includes instructions that automatically change the setup. The setup could also be changed manually in the Setup Mode.

Selecting Other Facilities

As an alternative to selecting an application, you can step through a number of other useful facilities:

Setup

Set up the printer using its built-in keyboard, see Chapter 7, “Setup Mode.”

Print Setup

Produce a printout of the printer’s current setup values (test label “Setup Info”).

Testfeed

Feed out a number of label, ticket, tag, or portions of continuous stock while the printer auto-adjusts its media feed and label stop/black mark sensor. It is recommended to perform a Testfeed each time you load a roll of labels from a new batch or a different brand.

Test Label

Print a series of four test labels (test labels “Diamonds”, “Chess”, “Bar Codes #1”, and Bar Codes #2”) in order to test the printout quality and printhead alignment. The labels are presented in an infinite loop, so you can print the series over and over again. Press <Enter> for each new label.

Default Setup

Reset all setup parameters to their default values, as listed in Chapter 6, “Setting Up the Printer.”

Software Update

Using the Zmodem communication tool, files can be downloaded from a PC, either to be stored on a standard CompactFlash memory card or to upgrade the printer’s firmware. The following options are available:

- Update CompactFlash card allows the printer to be used as a CompactFlash card programming device. Any files can be downloaded from a PC to a standard CompactFlash card inserted in the memory card slot in the printer’s rear plate.

A common application involves creating a firmware upgrade card from an upgrade file stored on a PC. You can use the card to upgrade the firmware in several printers simply by moving the card from printer to printer. Just insert the card, switch on the power, and wait for the prompts to appear in the printer’s display window.

- Update firmware is used to directly upgrade the firmware of a specific printer from a new firmware version stored as a file in a PC. If the printer is equipped with an EasyLAN Ethernet or Wireless board, the user must have access rights to upgrade the firmware, see the EasyLAN User's Guide.



Caution

If the CompactFlash card or upgrade file contains an earlier firmware version than the one in the printer, the printer's firmware will be downgraded without warning.

Firmware upgrade files can be found on www.intermec.com or be obtained from your local Intermec distributor.

Reboot

Corresponds to cycling the power to the printer. To exit Intermec Shell without having selected any application, select Reboot. Then wait for the 5 seconds countdown to finish, and the last selected application will be opened.

Intermec Shell v8.2 Overview

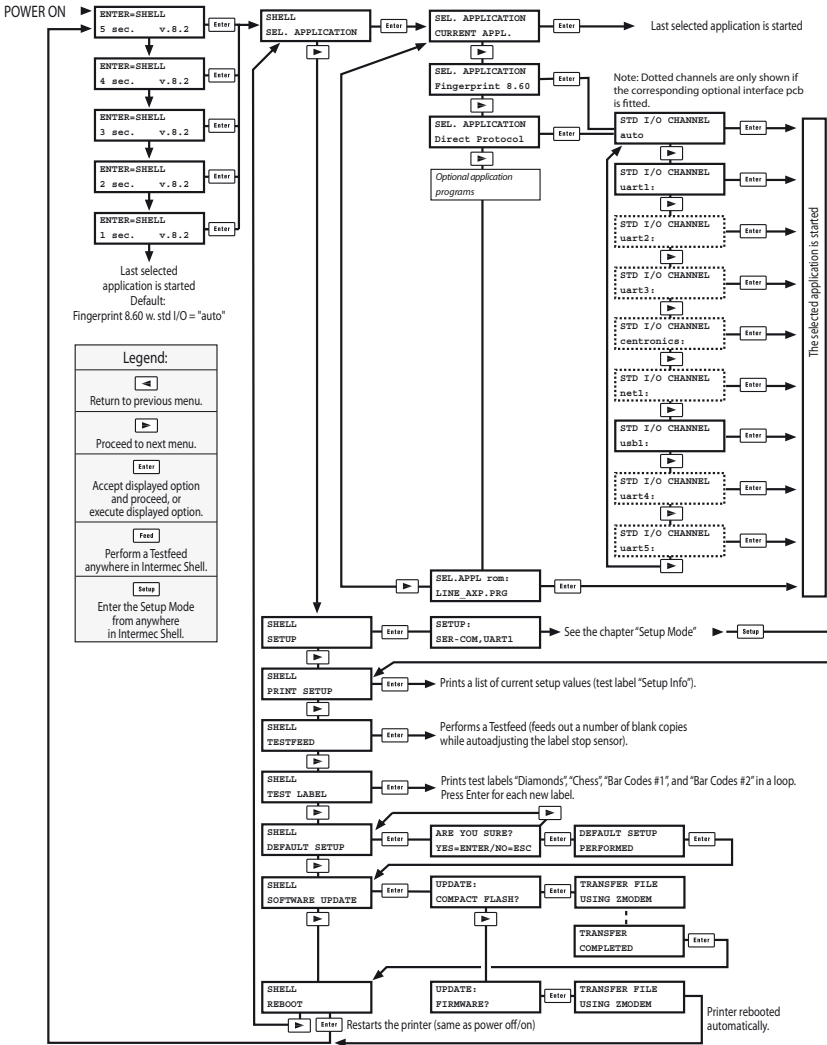

Line Analyzer

The Line Analyzer (LINE_AXP.PRG) is a program written in the Intermec Fingerprint programming language and is intended to help solving possible communication problems. As the name implies, the Line Analyzer captures all incoming characters on a specified communication channel and prints them on one or more labels.

Printable characters are printed in black-on-white, whereas control characters and space characters (ASCII 000–032 dec) are printed in white-on-black.

While the printer is receiving data, the “Ready” control lamp blinks. There is a 0.5 second timeout. That is, if no more characters have been received after 0.5 second, the program considers the transmission terminated and prints out a label.

As long as a continuous string of characters is being received, the program wraps the lines until the label is full and then starts to print another label. At the bottom of each label, the following information is printed:

- Page number
- Number of characters printed on the label
- Total number of characters received so far

The Line Analyzer is displayed as the option “LINE_AXP.PRG” under the “SEL. APPLICATION” menu. After the Line Analyzer has been selected and the printer has started up again, the printer feeds out two labels and the following menu is displayed:

```
Line Analyzer
Sel.port (1-8) 1
```

Enter the desired communication port using the numeric keys on the printer’s keyboard:

```
1 = "uart1:"
2 = "uart2:"
3 = "uart3:"
4 = "centronics:"
5 = "net1:"
6 = "usb1:"
7 = "uart4:"
8 = "uart5:"
```

Chapter 8—Intermec Shell Startup Program

If the printer is not fitted with the specified port, an error message appears in the display and you can select another port:

```
Line Analyzer  
Error:56
```



9 Options

This chapter describes the options available for the EasyCoder PM4i printer. The options can be factory installed, field-installed by an authorized service technician, or in some cases installed by the operator.

Introduction

The EasyCoder PM4i provides a high degree of flexibility because it has a modular design. By adding options to the basic printer, the EasyCoder PM4i can be adapted for a variety of applications. Most options should be installed by an authorized service technician or are only available as factory-installed options.

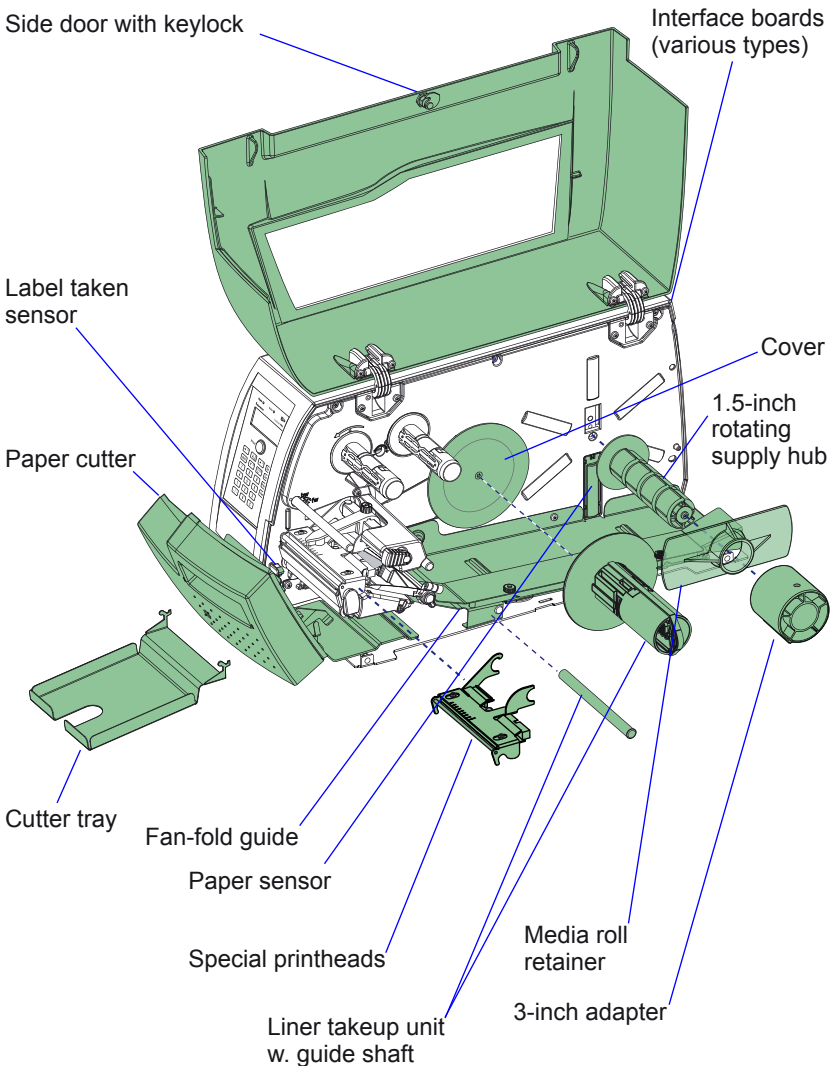

Integral Liner Takeup Unit

The integral liner takeup unit is an optional device for peel-off (self-strip) operation, which means that the labels are separated from a liner (backing paper) after printing and the liner is wound up on an internal hub. The unit also includes a guide shaft. Peel-off cannot be combined with an internal fan-fold guide. Also see Chapter 4, "Media Load, Peel-Off."

Paper Cutter

The paper cutter is designed to cut off continuous paper-based stock or liner between labels. The cut-off labels, tickets, or tags can be collected on an optional tray. The paper cutter can be controlled using the instructions CUT, CUT ON, and CUT OFF in Intermec Fingerprint and the Direct Protocol. Also see Chapter 4, "Media Load, Cut-Off."

Media Supply Hub

The rotating media supply hub is designed to fit media roll cores with an internal diameter of 38-40 mm (1.5 inch).

Paper Sensor

The paper sensor is fitted inside a plastic cover in the center section below the media supply hub. It can only be used with a rotating media supply hub and detects when the remaining media supply has reached a preset minimum diameter, as specified in the Setup Mode.

Tear-Off Bar

The adjustable tear-off bar is particularly useful when delicate media is used in peel-off operation.

Media Roll Retainer

The retainer is intended to keep large media rolls in place when using a rotating media supply hub. It restricts the maximum media width to 100 mm (3.9 inches). Installed by the operator.

3-inch Adapter

The 3-inch/76 mm adapter is used with a rotating media supply hub and makes it possible to use media rolls with 3 inch/76 mm inner diameter cores. The adapter is pressed onto the hub and secured by a screw. Not used with a media supply roll post. Installed by the operator.

Label Taken Sensor

The Label Taken Sensor (LTS) is a photoelectric sensor that detects if the latest printed label has been removed before printing another copy. The LTS can be enabled or disabled by means of the instructions LTS& ON and LTS& OFF respectively in Intermec Fingerprint and the Direct Protocol. The LTS cannot be used in connection with a paper cutter.

Real Time Clock

The Real Time Clock circuit (RTC) relieves the operator or the host from having to set the clock/calendar using the Intermec Fingerprint instructions DATE\$ and TIME\$ after each power up. The RTC has its own backup battery that will last 10 years or more.

External Keyboard Converter

With this simple converter, a standard ps2 keyboard can be connected to the printer's serial port.

Internal Fan-Fold Guide

This guide facilitates media load from an external supply to the rear of the printer and provides superior guiding of the media. It cannot be used in connection with peel-off (self-strip) operation and cannot be combined with a label slack absorber, which may restrict the maximum print speed somewhat.

Side Door with Keylock

If the media is valuable or sensitive, such as tickets, you can install a side door that can be locked with a key. Can be installed by the operator.

Font Card

This is a CompactFlash memory card loaded with fonts. With a Font Card installed, the user gets access to double-byte font sets including Kanji, Korean and Chinese.

CompactFlash Protection Plate

The protection plate encloses an inserted CompactFlash card and makes it more difficult to steal. See Chapter 3 for illustration. Can be installed by the operator.

RFID Kit

The EasyCoder PM4i can be equipped with the capability to read and write data to labels fitted with RFID (Radio Frequency IDentification) inlays. RFID Kits come either factory installed or as a field-installable option.

Special Printheads

As standard, the printer is fitted with an 8 dots/mm (203.2 dots/inch) thermal printhead. There are also a number of optional printheads for special applications. The printhead can easily be replaced or exchanged by the operator as described in Chapter 11.

8 dots/mm (203.2 dots per inch)

Media Thickness	Standard/Option
Max 175 μm (7 mils)	Standard
170-220 μm (6.6-8.7 mils)	Option
170-220 μm (6.6-8.7 mils) 3mm offset	Option

11.81 dots/mm (300 dots per inch)

Media Thickness	Standard/Option
Max 175 μm (7 mils)	Option
170-220 μm (6.6-8.7 mils)	Option

Interface Boards

A number of interface boards are available for use with the EasyCoder

Chapter 9—Options

PM4i printer. The interface boards are either factory-fitted or can be installed on-site by an authorized service technician.

The EasyCoder PM4i can accommodate one EasyLAN interface board plus one or two other interface boards.

EasyLAN boards:

- EasyLAN Ethernet interface
- EasyLAN Wireless interface

Other communication boards:

- Parallel Interface Board (IEEE 1284)
- Double Serial Interface Board
- Serial/Industrial Interface Board
- RFID/Serial Interface Board

A decorative graphic consisting of two overlapping circles. The larger circle is light gray and partially encloses the number '10'. The smaller circle is also light gray and overlaps the bottom of the larger circle. The number '10' is in a large, bold, black font.

10 Troubleshooting

This chapter describes how the Ready-to-Work indicators work. It also lists various possible cases of inferior printout quality, describes possible causes, and suggests remedies.

Ready-to-Work indicator

The readiness of the printer, individually or as a part of a solution, is indicated by the blue Ready-to-Work (RtW) indicator.

If the Ready-to-Work indicator blinks or is switched off, the printer is not ready. Further information can be obtained in the display window by pressing the <F5/i> key. In case of several errors or similar conditions occurring simultaneously, only the most significant error is displayed. Once this error has been cleared, next remaining error is displayed.

The printer will also return error messages to the host, provided there is a working two-way communication. Refer to the *Intermec Fingerprint v8.xx, Programmer's Reference Manual*.

Provided the printer is connected to a network, all conditions that prevents printing are reported to the Easy ADC Console. The Easy ADC Console is a PC-based software which allows a supervisor to monitor all connected devices that have a Ready-to-Work indicator, including hand-held computers, access points, and printers.

Display Messages and LED Indications

Error/Event	RtW	Error No.	Comment
Operational	On	0	No error
Out of paper	Blink	1005	
Next label not found	Blink	1031	
Label not taken	Blink		
Out of transfer ribbon	Blink	1027	
Transfer ribbon is installed	Blink	1058	
Head lifted	Blink	1022	
Cutter does not respond	Blink	1059	
Cutter error1	Blink	1701	
Cutter error2	Blink	1702	
Cutter error3	Blink	1703	
Cutter open	Blink	1704	
Lss too high	Blink	1007	
Lss too low	Blink	1008	
Testfeed not done	Blink	1606	
No RFID support installed	Blink	1320	
No tag found	Blink	1321	
Pause Mode entered	Blink		
Setup Mode entered	Blink		Including interactive setup from Fingerprint/Direct Protocol
IP link error	Blink		See note 1, 2, and 3
IP configuration error	Blink		See note 1, 3, and 4
Generic DP error	Blink		See note 5
Press any key to continue	Blink		See note 6
Application load error	Blink		See note 7
RtW blink by application	Blink		Set by Fingerprint instruction SYSHEALTH
RtW off by application	Off		Set by Fingerprint instruction SYSHEALTH
Application break	Off		See note 8
Printhead not found	Off		
Rebooted	Off		

Chapter 10—Troubleshooting

Initializing	Off		Set at startup until operational
Printer crash	Off		See note 3 and 9
Printer turned off	Off		
Maintenance	Off		Set when upgrading
Power supply Over temperature	Off	1718	
Printhead too hot	Off	1088	See note 10

Note 1: This is only applicable for printers equipped with an EasyLAN interface.

Note 2: A printer that is equipped with an EasyLAN interface, but is not connected to a network, will have a blinking RtW. To avoid this, the user can set “IP SELECTION” to “MANUAL” and “IP ADDRESS” to “0.0.0.0”. This will indicate that the user does not regard the lack of network connection as an error.

Note 3: No trap can be sent when this error/event occurs.

Note 4: This error indicates that the printer has not received an IP address. It is only applicable for printers with IP SELECTION set to DHCP and/or BOOTP.

Note 5: In the Direct Protocol, the user can enable error handling for specific errors using the ERROR statement. When errors added to the built-in error handling occur, this event will be set. The text included in the snmp trap is the standard text corresponding to the error.

Note 6: If an error occurs in the Fingerprint immediate mode, for example “out of paper” when the print key is pressed, this event will be set.

Note 7: If an application is started but does not execute, the RtW will blink. This will occur for example if there is a syntax error in the loaded program file.

This is useful when a printer has an AUTOEXEC.BAT file (startup file) that is supposed to run automatically.

Note 8: When execution is stopped with user break (SHIFT + PAUSE) or due to a runtime error, the RtW shall be off. It will be set to on if the user changes mode to Direct Protocol or runs an application.

If, however, the application program handles the user break (ON BREAK) or the runtime error (ON ERROR GOTO), the RtW will not be affected. In this case, it is up to the application to set the status.





Note 9: At most, but not all, printer crashes the console is reset. This will turn off the RtW.

Note 10: If the printhead temperature raises above 100°C, error 1088 occurs.



In Fingerprint, printing will be aborted. Resuming printing after the printhead has cooled off to 85°C must be handled by the application program.

In the Direct Protocol, the printing is paused but will be automatically resumed when the printhead has cooled off to 85°C. Meanwhile, the printer is able to receive instructions

and data until the buffer is filled.

Symptom	Possible Cause	Remedy	Refer to
Overall weak print-out	Wrong Paper Type parameter	Change parameter	Chapter 6
	Contrast value too low	Change parameter	Chapter 6
	Printhead pressure too low	Adjust	Chapter 12
	Worn printhead	Replace printhead	Chapter 11
	Wrong printhead voltage	Replace CPU board	 Call Service
Printout weaker on one side	Uneven printhead pressure	Adjust arm alignment	Chapter 12
Weak spots	Foreign particles on media	Clean or replace	Chapters 4 & 5
	Media/ribbon don't match	Change to matching media	Chapter 6
	Poor media or ribbon quality	Select a better brand of media or ribbon	Chapter 6
	Worn printhead	Replace printhead	Chapter 11
	Worn platen roller	Check/replace	 Call Service
Overall dark print-out	Wrong Paper Type parameter	Change parameter	Chapter 6
	Contrast value too high	Change parameter	Chapter 6
	Printhead pressure too high	Adjust	Chapter 12
	Wrong printhead voltage	Replace CPU board	 Call Service
Excessive bleeding	Wrong Paper Type	Change parameter	Chapter 6
	Contrast value too high	Change parameter	Chapter 6
	Printhead pressure too high	Adjust	Chapter 12
	Faulty energy control	Replace CPU board	 Call Service
Dark lines along media path	Foreign objects on printhead	Clean printhead	Chapter 11

Chapter 10—Troubleshooting

White vertical lines	Printhead dirty	Clean printhead	Chapter 11
	Missing printhead dots	Replace printhead	Chapter 11
Large part of dot line missing	Wrong X-start or Width parameter	Change parameter	Chapter 6
	Failing printhead	Replace printhead	Chapter 11
	Failing strobe signal	Check CPU-board	 Call Service
Printout missing along inner edge	Bad media alignment	Adjust	Chapter 4
	X-start parameter value too low	Increase	Chapter 6
Transfer ribbon breaks	Ribbon not fitted correctly	Reload ribbon	Chapter 5
	Wrong paper type parameter	Change parameter, then clean printhead	Chapter 6
	Bad energy control	Adjust	 Call Service
Transfer ribbon wrinkles	Faulty ribbon break shaft adjustment	Adjust	Chapter 12
	Incorrect edge guide adjustment	Adjust	Chapter 4
	Too strong printhead pressure	Adjust	Chapter 12
No thermal transfer printout	Ink-coated side does not face media	Reload ribbon	Chapter 5
Media feed not working properly	Changed media characteristics	Perform a TESTFEED	Chapter 4
	Wrong start- and stop adjust values	Check/change	Chapter 6
	Wrong Media Type parameter	Check/change	Chapter 6
	Wrong LSS position	Check/change	Chapter 12
	Dirty sensors	Clean media guides	Chapter 11
	Faulty sensors	Replace	 Call Service



11 Maintenance

This chapter describes how the operator can maintain the printer. Regular maintenance is important for the printout quality and for the life of the printhead. The chapter covers the following topics:

- Printhead cleaning
- External cleaning
- Cleaning the media guides
- Printhead replacement
- Media jams



When cleaning or replacing the printhead, take ample precautions to avoid electrostatic discharges.

Printhead Cleaning

Cleaning the printhead on a regular basis is important for the life of the printhead and for the printout quality. You should clean the printhead each time you replace the media. This section describes how to clean the printhead using cleaning cards. If additional cleaning is required, for example removing adhesive residue from the platen roller or tear bar, use a cotton swab moistened with isopropyl alcohol.



Isopropyl alcohol [(CH₃)₂CHOH; CAS 67-63-0] is a highly flammable, moderately toxic, and mildly irritating substance.

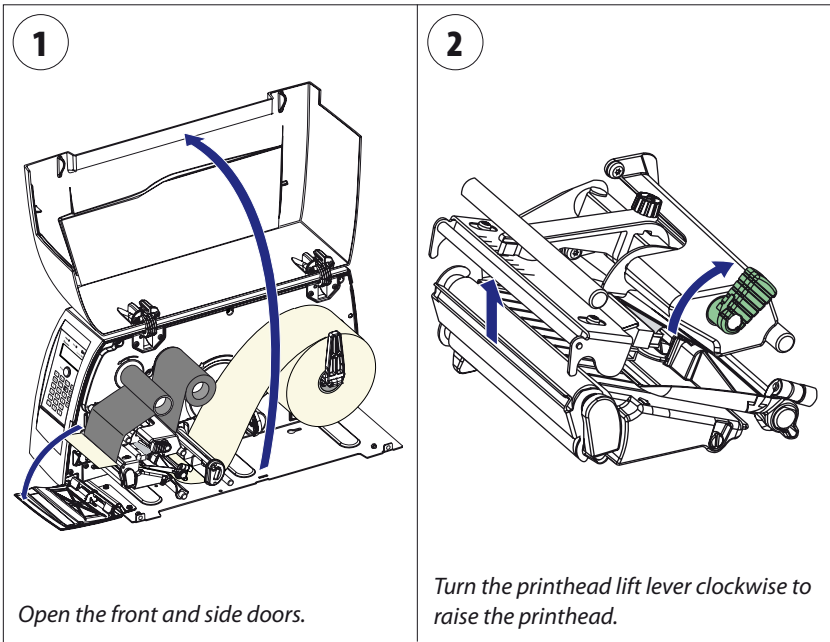

Printhead Cleaning, cont.

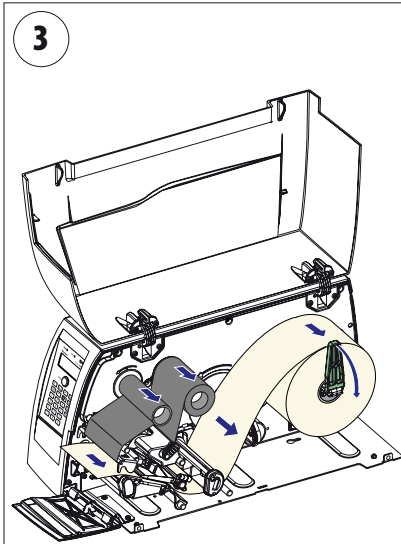

Remove any media and transfer ribbon.

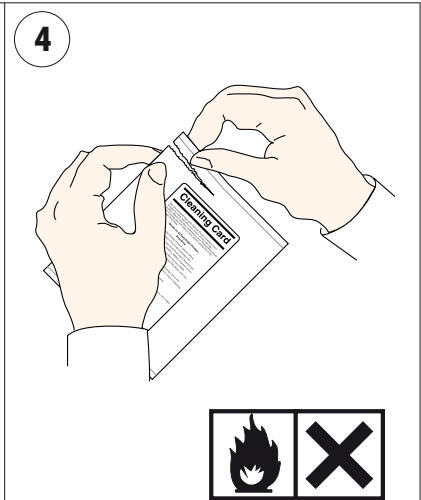

Open the cleaning card envelope and pull out the cleaning card. Read the warning text.

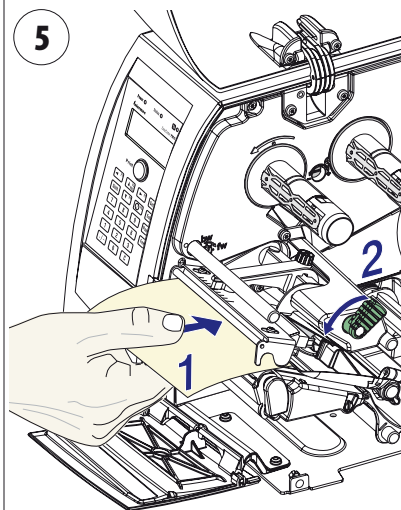

Insert most of the cleaning card under the printhead (1). Engage the printhead (2).

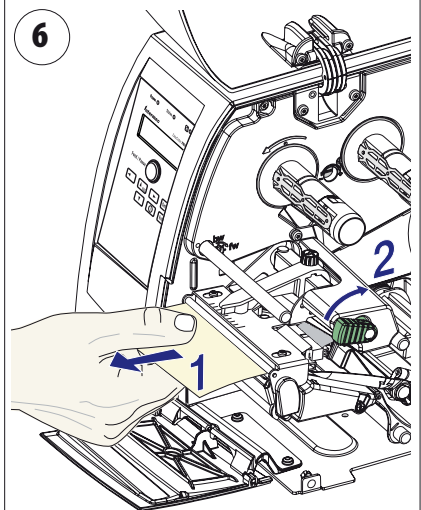

Pull out the cleaning card (1) and raise the printhead (2).

Printhead Cleaning, cont.

7

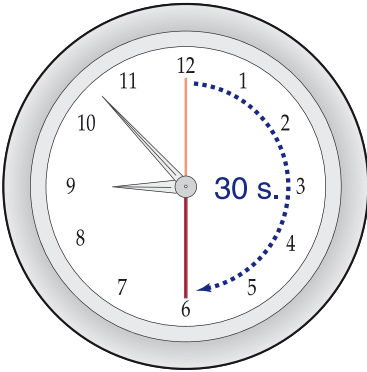

Wait for approx. 30 seconds to allow the cleaning fluid to dissolve the residue.

8

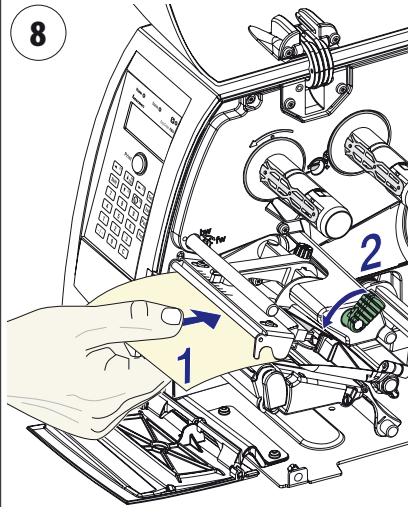

Insert most of the cleaning card under the printhead again (1). Engage the printhead (2).

9

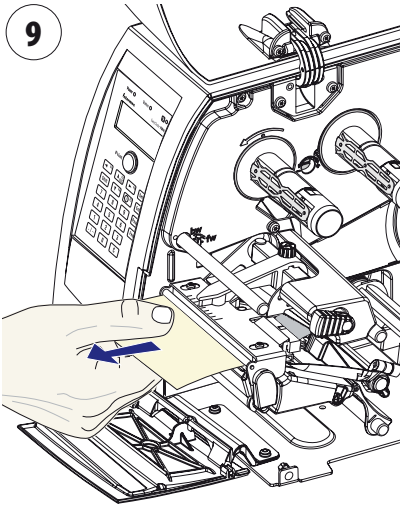



Pull out the cleaning card. If necessary, repeat the process with a fresh cleaning card.

10

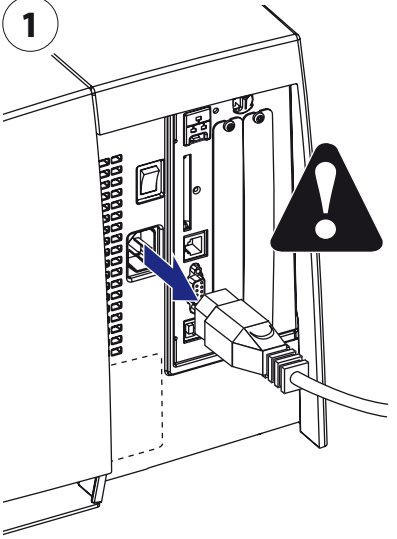
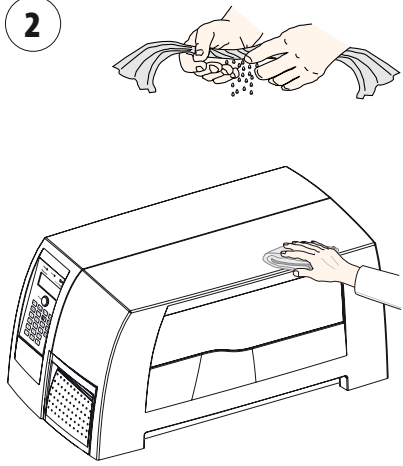
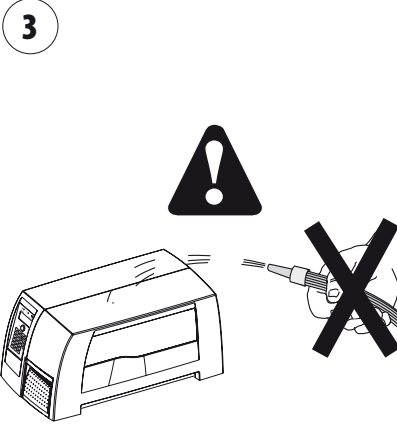

Allow the cleaned parts to dry before loading any media (and ribbon).

External Cleaning

<p>1</p>  <p>Always remove the power cord before cleaning!</p>	<p>2</p>  <p>Wipe external surfaces with a soft cloth slightly moistened with water or a mild detergent.</p>
<p>3</p>  <p>Never spray the printer. Protect it from water when cleaning the premises.</p>	<p>4</p>  <p>Never use any sharp tools for removing stuck labels. The printhead and rollers are delicate.</p>

Cleaning the Media Guides



Some Intermec RFID option kits use the media guide to house the RFID antenna. Be extra careful not to damage the antenna when following the procedure described below.

Both parts of the label stop sensor, which controls the media feed, are covered by plastic guides. The guides are transparent to allow the light to pass between the two parts of the label stop sensor. These areas must be kept clean from dust, stuck labels, and adhesive residue.

If the printer starts to feed out labels in an unexpected way, pull out the upper guide as described below and check for any object that may block the beam of light (dust, stuck labels, adhesive residue, etc.). If necessary, clean the guides using a cleaning card or a soft cloth soaked with isopropyl alcohol. Do not use any other type of chemical. Be careful not to scratch the guides.



Isopropyl alcohol [(CH₃)₂CHOH; CAS 67-63-0] is a highly flammable, moderately toxic, and mildly irritating substance.

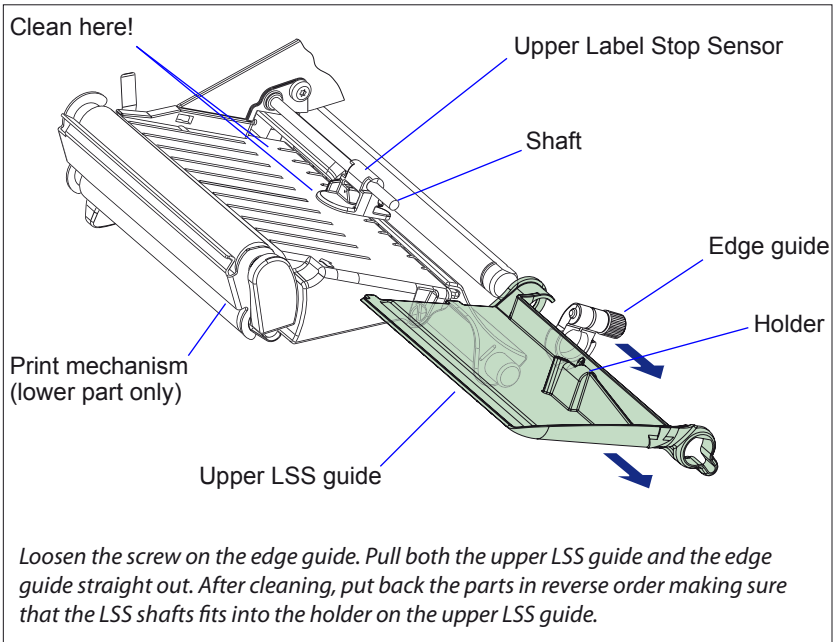

Printhead Replacement

The printhead is subject to wear both from the direct thermal media (or ribbon) and from the rapid heating and cooling process during printing. Thus, the printhead will require periodic replacement.

Time between printhead replacements depends on the print images, the type of direct thermal media or ribbon in use, the amount of energy to the printhead, the print speed, the ambient temperature, and several other factors.



While replacing the printhead, the power must be off. The firmware will not detect the new printhead resistance and density until the printer has been restarted.



Note: Check that the density and dot alignment of the new printhead matches the printhead you are replacing. However, you can switch between alignments and densities at will, but be advised that the printout will be affected accordingly.

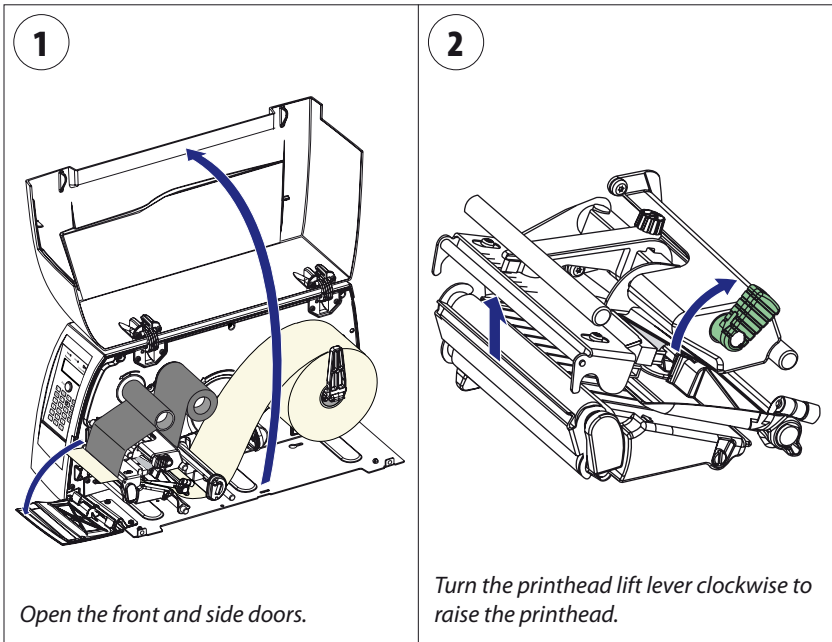

Printhead Replacement, cont.

3

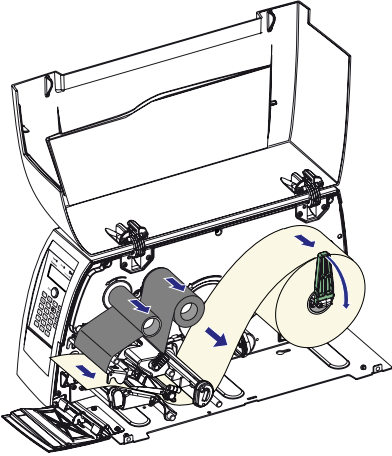

Remove any media and transfer ribbon.

4

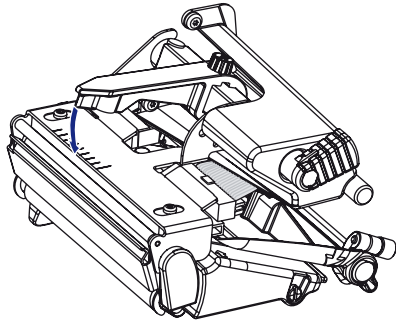

Pull the printhead bracket away from the magnet in the pressure arm.

5

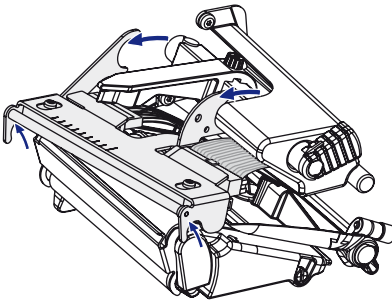

Disconnect the printhead bracket from the print mechanism as indicated by the arrows and pull out the printhead as far as the cables allow.

6

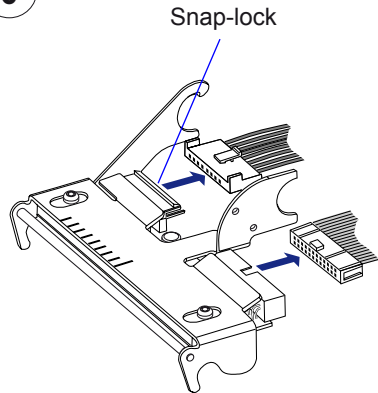

Disconnect the cables from the printhead. Note the snap-lock on the inner connector. Pull at the connectors—not at the cables!

Printhead Replacement, cont.

7

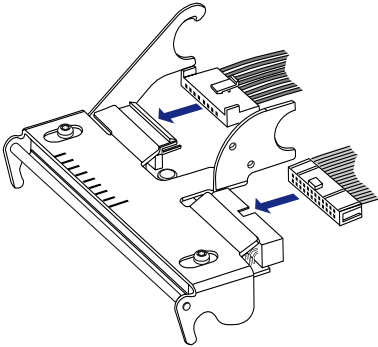

Connect the two cables to the replacement printhead.

8

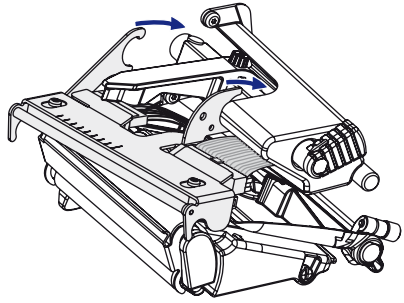

Put back the printhead in reverse order and check that the printhead cables run freely.

9

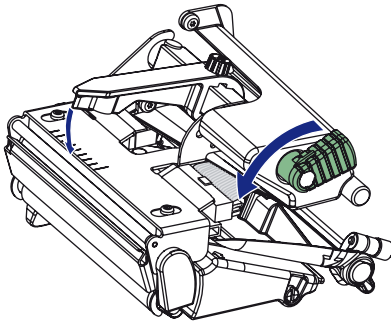

Turn the printhead lift lever counter-clockwise so the magnet engages the printhead bracket.

10

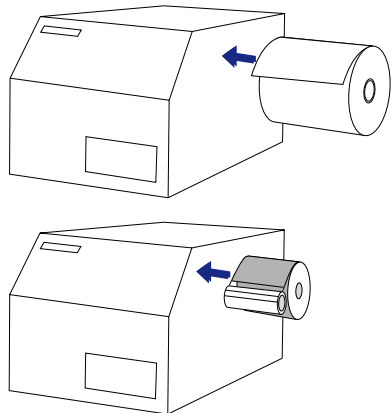

Load a new supply of media and ribbon, as described earlier in this manual.

Media Jams

Should a media jam occur in the print mechanism, proceed this way to clear it:

- Always switch off the power before starting to clear the jammed media.
- Raise the printhead and pull out the media.
- If the media has been wound up or has stuck on the platen roller, carefully remove it by hand without using any sharp tools that can damage the delicate platen roller or printhead. Avoid rotating the platen roller.



Caution

If you must pull away the media by force causing the platen roller to rotate, it is very important that the power has been off for a minute or more. If not, the electronics can be damaged beyond repair.

- Cut off any damaged or wrinkled part.
- Check if there is any adhesive somewhere in the print mechanism, clean using a cleaning card or cotton swab soaked in isopropyl alcohol.



Warning

Isopropyl alcohol [(CH₃)₂CHOH; CAS 67-63-0] is a highly flammable, moderately toxic, and mildly irritating substance.

- Reload the media as described in Chapter 4.
- Switch on the power.
- Readjust the media feed by pressing the <Feed> key.



12 Adjustments

This chapter describes how the operator can adjust the printer. The chapter covers the following topics:

- Narrow media adjustment
- Label stop sensor adjustment
- Printhead pressure adjustment
- Ribbon break shaft adjustment
- Label taken sensor adjustment

Narrow Media

The printer is factory-adjusted for full-size media width. When using media less than full width, it is recommended that you adjust the position of the pressure arm so it becomes centered with the media. Thereby, an even pressure across the media is obtained.

A poorly adjusted pressure arm may be detected by a weaker printout on either side of the media path.

To adjust the pressure arm, proceed as follows:

- Loosen the knurled nut that holds the pressure arm. Move the arm inwards or outwards until the arrow on the tip of the arm becomes centered with the media.

While moving the arm, push at the part where the nut is situated, not at the tip. If the arm is hard to move, lift the printhead and pull the printhead bracket free from the magnet in the arm.

- After having centered the arm, lock it by tightening the nut.
- Remember to adjust all edge guides too.

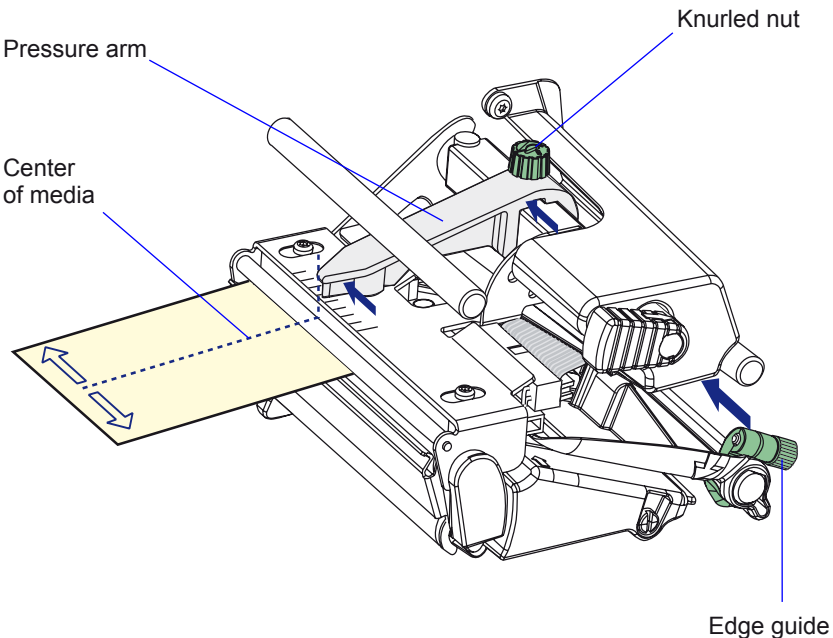

Label Stop Sensor

The label stop/black mark sensor (LSS) is a photoelectric sensor that controls the printer's media feed by detecting gaps between labels, or slots or black marks in continuous stock, depending on the printer's setup in regard of media type (see Chapter 6, "Setting Up the Printer"). An obvious prerequisite is that the LSS must be aligned with the gaps, slots, or black marks. If using irregularly shaped labels, align the LSS with the front tips of the labels.

The LSS can be moved laterally from the inner edge of the media path and 57 mm (2.24 inches) outwards, which corresponds to the center-line of full width media. There is one part of the sensor on top of the upper media guide and another part underneath the lower guide. Using a straight-slot screwdriver, turn the adjustment screw until the point of detection on the upper sensor becomes aligned with the center of the slots or marks in the media, when you look into the print mechanism from the front with the printhead lifted.

- Rotate the screw clockwise to move the sensor towards the center section.
- Rotate the screw counterclockwise to move the sensor outwards, away from the center section.

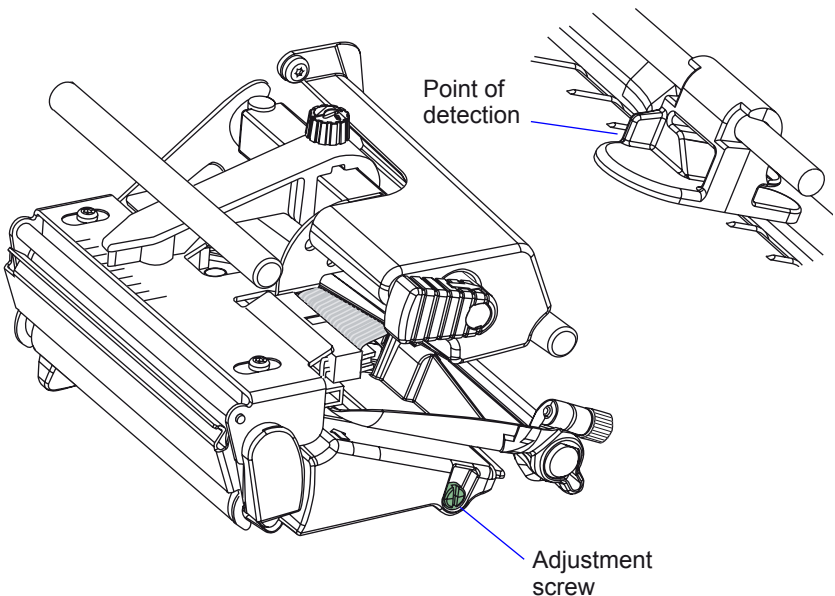

Chapter 12—Adjustments

In the Print Defines part of the Setup Mode, you have two ways to test the label stop sensor if you have a detection problem; LSS Auto and LSS Manual.

The menu only provides indications from the label stop sensor unit. The testing menu can determine if the sensor unit is not physically in position, is blocked by dust or stuck labels, or is defective in some way. Furthermore, this is an aid if media has detection complication.



Note: There is no way to adjust the LSS-function; the menu only indicate values from the LSS obtained by performing a TESTFEED operation.

LSS Auto is the quick and normal way to determine if the label stop sensor works properly and is able to detect gaps, slots, or black marks.

LSS Manual shows the actual setting provided by the latest TESTFEED operation. It is also possible to try other settings. LSS Manual is primarily intended for service and is not described in this manual.

LSS Auto

- Check that the printer is set up for the type of media loaded in your printer (Setup Mode/Media/Media type/LABELS (w GAPS);TICKET (w MARK), TICKET (w GAPS), FIX LENGTH STRIP; or VAR LENGTH STRIP.
- Perform a TESTFEED by simultaneously pressing the <Shift> and <Feed> keys on the printer's keyboard.
- Make sure that there is a label—not a gap or mark—at the LSS.
- Check that the media is routed as close to the center section as the guides allow.
- Enter the Setup Mode (see Chapter 7) and go to Setup Mode/Print Defines/LSS Test/LSS Auto.
- The menu should look like this with the cursor placed in the center:



LSS Auto

- **Gap or slot detection:**

Lift the printhead and pull out the media slowly. When the LSS detects a gap or a detection slot, the cursor moves to the right.



- **Black mark detection:**

Lift the printhead and pull out the media slowly. When the LSS detects a black, the cursor moves to the left.



- It is possible to refresh the centered cursor position by pressing the <▼/F4> key.
- If the cursor behaves as described above, the LSS is working and is properly aligned with the gaps, slots, or black marks.
- If the cursor does not react on a gap, slot, or black mark, check this:
 - Is the LSS laterally aligned with the slots or black marks?
 - Are both the upper and lower part of the LSS aligned with each other?
 - Is the transfer ribbon properly loaded so it does not interfere with the LSS? (See Chapter 5.)
 - Are the LSS guides clean and free from stuck labels or other objects that will interfere with the light that goes from one part of the LSS to the other? If not, clean as described in Chapter 11.
 - Does the media have some kind of preprint that can disturb the detection?
 - Is there too little difference between the black marks and the surrounding areas?
 - Does the liner have too little transparency?
 - Does the LSS work with another type of media? (Remember to change the Media Type setup and perform a new TESTFEED.)

Printhead Pressure

The pressure of the thermal printhead against the direct thermal media is factory-adjusted. However, the use of thicker or thinner media than normal could require the printhead pressure to be readjusted.

Using a straight-slot screwdriver, turn the adjustment screw clockwise for more pressure (+) or counterclockwise for less pressure (-). Print a few labels, preferably test labels (see Chapter 6, “Setting Up the Printer”) and check the printout. Increased pressure generally gives a darker printout and vice versa. Repeat until the desired result is obtained.

To return to the factory setting, tighten the screw (+) as far as it goes and then loosen it (-) four full turns.



Do not use a higher printhead pressure than necessary, because it may increase the wear of the printhead and shorten its life.

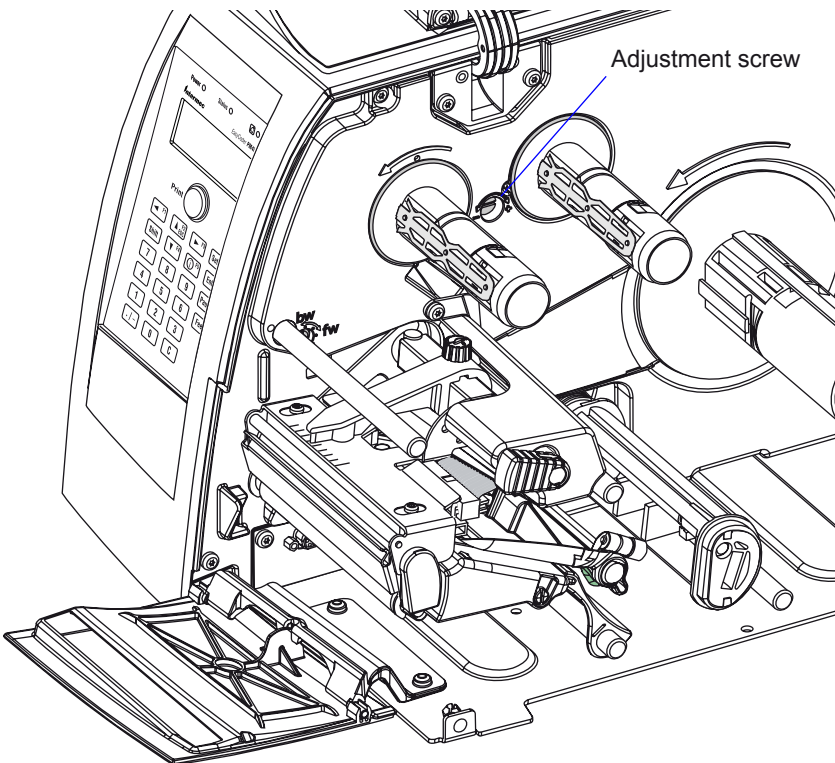

Ribbon Break Shaft

If ribbon wrinkling occurs, you may need to adjust the alignment of the front ribbon break shaft so that it runs parallel to the printhead and the ribbon supply and rewind hubs. The adjustment is done using a straight-slot screw that is located immediately behind the front ribbon break shaft.

- If the ribbon tends to slide outwards, turn the screw carefully clockwise (fw) to move the outer end of the break shaft forward.
- If the ribbon tends to slide inwards, turn the screw carefully counter-clockwise (bw) to move the outer end of the break shaft backward.



Caution

Before readjusting the break shaft, make sure that there is no other cause for the wrinkling of the ribbon. (See Chapter 10, “Troubleshooting.”)

Adjustment screw

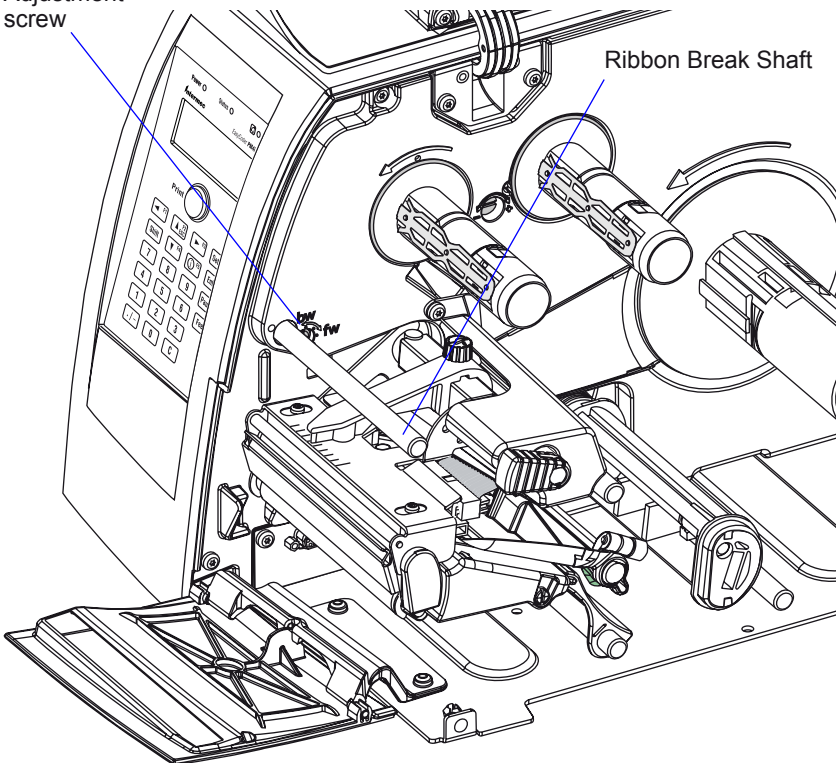

LTS (Label Taken Sensor)

The sensitivity of the LTS may need to be adjusted according to ambient light conditions and reflective characteristics of the back side of the media. This is done in the Setup Mode (Print Defs/LTS), see Chapter 7. You can also check that the LTS works properly.

The LTS setup options are only displayed if an optional label taken sensor is installed in the printer.

LTS Adjust

Press <Enter>. A label is fed out. Remove the label and press <Enter> again. A menu shows the sensitivity automatically selected by the firmware and the range, in which the LTS will work. Press <Enter> again and you will proceed to the LTS Test menu.

LTS Test

Press <Enter>. A label is fed out. Remove the label and a new label should be fed out automatically. Repeat until you are sure the LTS works properly. Then press <Enter> to stop and exit.

LTS Value

Press <Enter>. You can enter a new value in the range indicated in the LTS Adjust menu (see above). Min/max values are in the range 0 to 10.

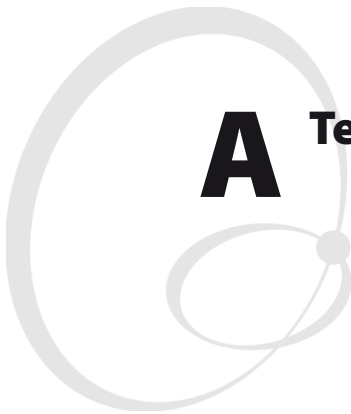

A **Technical Data**

This appendix lists the technical data for the printer. Please note that Intermec reserves the right to change without prior notice and that this information does not represent a commitment on the part of Intermec.

Appendix A—Technical Data

Printing		
Print Technique	Direct Thermal and Thermal Transfer	
Printhead Resolution	8 dots/mm (203.2 dpi)	Option 300 dpi
Print Speed (variable)	100 to 200 mm/sec. (\approx 4 to 8 in./sec.) 100 to 150 mm/sec. (\approx 4 to 6 in./sec.)	8 dots/mm 300 dpi
Print Width (max)	104 mm (4.095 in.) 105.7 mm (4.161 inches)	8 dots/mm 300 dpi
Print Length (max)	32767 dots = 409.5 cm (161.25 in.) ¹	
Media Width (min/max)	25 to 114.3 mm (1 to 4.5 in.)	
Media Roll Diameter (max)	213 mm (8.38 in.)	
Media Roll Core Diameter	38 to 40 mm (1.5 in.) or 76 mm (3 in.)	
Ribbon Width (min/max)	25 to 110 mm (1 to 4.33 in.)	
Ribbon Roll Diameter (outer), max.	82 mm (3.2 in.)	\approx 450 m (1475 ft) of ribbon
Ribbon Roll Core Diameter (inner)	25.4 mm (1.00 inches)	
Print Directions	4	
Modes of Operation		
Tear-Off (Straight-through)	Yes	
Peel-Off (Self-strip)	Option	
Cut-Off	Option	With cutter
Firmware		
Operating System	Intermec Fingerprint v8.70	Incl. Direct Protocol
Smooth Fonts	TrueDoc and TrueType fonts	
Resident scaleable fonts	15	Unicode fonts ²
Resident bar codes	59	
Startup Program (std)	Intermec Shell v8.2	
Physical Measures		
Dimensions (W × L × H)	298 × 543 × 261 mm (11.7 × 21.4 × 10.3 in)	
Weight (excluding media)	13.5 kg (30 pounds)	
Ambient Operating Temperature	+5°C to +40°C (+41°F to +104°F)	
Humidity	20 to 80% non-condensing	

Electronics		
Microprocessor	32 bit RISC	
On-board Flash SIMMs	2 sockets for 4MB or 8MB each	Std. 1 x 4MB
On-board SDRAM SIMM	1 socket for 8MB or 16MB	Std. 8MB
Power Supply		
AC Voltage	90 to 265 VAC, 45 to 65 Hz	
PFC Regulation	IEC 61000-3-2	
Power Consumption	Standby 15W; Peak 300W	
Sensors		
Label Gap/Black Mark/ Out of Media	Yes	Variable position
Printhead Lifted	Yes	
Ribbon End/Ribbon Low	Yes	
Paper sensor	Option	
Controls		
Control Lamps	3	
Display	2 x 16 character LCD	Background light
Keyboard	22 keys membrane-switch type	
Print button	1	
Beeper	Yes	
Data Interfaces		
Serial	1 x RS-232 + 1 x USB	
Bar Code Wand	Yes	
Connection for Optional Interface Boards	1 + 2	1 for EasyLAN 2 for other boards
Finisher Interface	1	For cutter etc.
Memory Card Adapter	1	CompactFlash cards
Accessories and Options		
Special Printheads	8 dots/mm (202.3 dpi): 2 types 11.81 dots/mm (300 dpi): 2 types	See Chapter 9
Integral Self-strip Unit with Liner Takeup	Option	For peel-off operation

Appendix A—Technical Data

Rotating Media Supply Hub	Option	Replaces supply post
3-inch Adapter for Media	Option	Supply hub only
Media Roll Retainer	Option	Supply hub only
Internal Fan-fold Guide	Option	
Side Door with Keylock	Option	
Cutter and Tray	Option	
Label Taken Sensor	Option	
Real Time Clock	Option	10+ years life
RS-232 Cable	Option	
Parallel Interface Cable	Option	
Parallel Interface Board	Option	IEEE 1284
Double Serial Interface Board	Option	2 serial ports
Serial/Industrial Interface Board	Option	1 serial port 1 industrial interface port
EasyLAN Ethernet Interface	Option	
EasyLAN Wireless Interface	Option	
External Alphanumeric Keyboard	Option	
CompactFlash Cards	Option	8MB-1GB
RFID Kit	Option	
CompactFlash Protection Plate	Option	

¹/. The max. print length is also restricted by the amount of free SDRAM memory.

²/. Latin, Greek, and Cyrillic fonts according to Unicode standard are included.

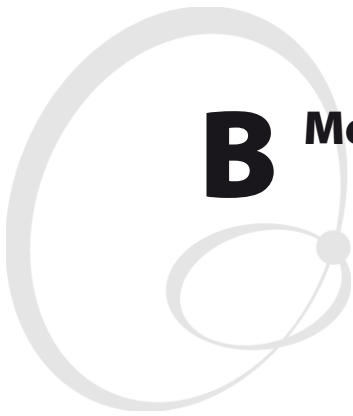

B Media Specifications

This appendix specifies the physical measures for various types of media.

Media Roll Size

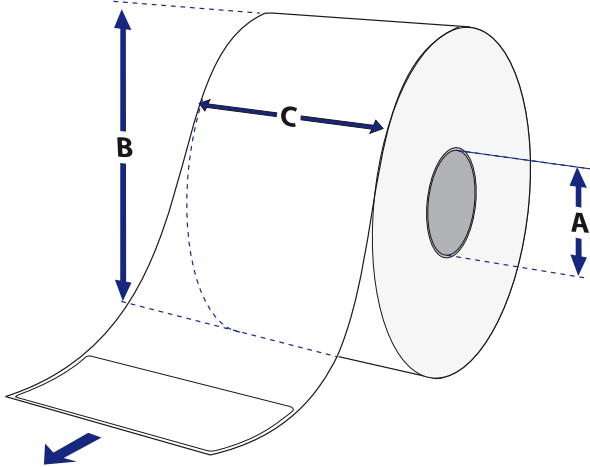

Core

Diameters (A): 38-40 mm (1.5 inches) or 76.2 mm (3 inches)
Width: Must not protrude outside the media.



Caution

The media must be wound up on the core in such a way that the printer can pull the end free.

Roll

Max. diameter (B):	213 mm	(8.38 inches)
Max. width (C):	114.3 mm	(4.50 inches)
Min. width (standard) (C):	25 mm	(1.00 inches)
Min. width (fan-fold guides) (C):	40 mm	(1.57 inches)

The maximum recommended media thickness is 175 μ m (7 mils) with the standard printhead or 220 μ m (8.7 mils) with a special printhead. Thicker media may be used, but print quality will be reduced. The stiffness is also important and must be balanced against thickness to maintain print quality.

Media rolls to be loaded inside the printer should be wound with the printable side facing outwards.

The media supply must not be exposed to dust, sand, grit, etc. Any hard particles, however small, can damage the printhead.

Media

Media with RFID tags/inlays

When printing on RFID media, special consideration must be taken to the position and shape of the tag. Specific recommendations for different kinds of Intermec-approved RFID media can be found on the Intermec website. Additional information is provided in the documentation that came with your RFID kit.

Non-Adhesive Strip

⇐ a ⇒ Media Width

Maximum: 114.3 mm (4.50 inches)

Minimum: 25.0 mm (1.00 inches)

Media Type Setup

- Fix length strip
- Var length strip

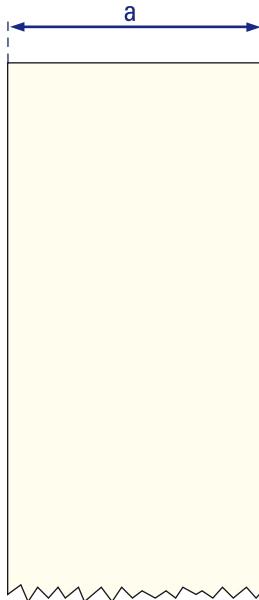

Self-Adhesive Strip

⇐ **a** ⇒ **Media Width (including liner)**

Maximum: 114.3 mm (4.50 inches)

Minimum: 25.0 mm (1.00 inches)

⇐ **b** ⇒ **Liner**

The liner must not extend more than a total of 1.6 mm (0.06 inches) outside the face material and should protrude equally on both sides.

⇐ **c** ⇒ **Media Width (excluding liner)**

Maximum: 112.7 mm (4.43 inches)

Minimum: 23.8 mm (0.94 inches)

Media Type Setup

- Fix length strip
- Var length strip

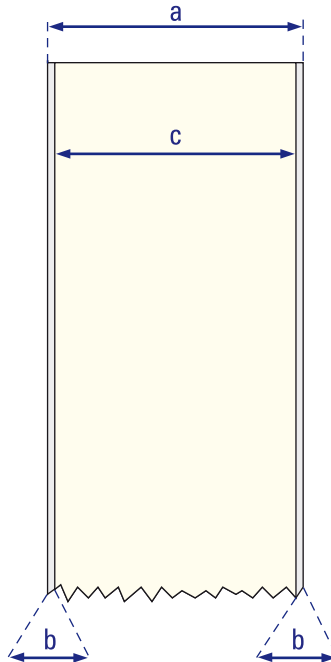

Self-Adhesive Labels

← a ⇒ Media Width (including liner)

Maximum:	114.3 mm (4.50 inches)
Minimum:	25.0 mm (1.00 inches)

← b ⇒ Liner

The backing paper must not extend more than a total of 1.6 mm (0.06 inches) outside the labels and should protrude equally on both side. Recommended minimum transparency: 40% (DIN 53147).

← c ⇒ Label Width (excluding liner)

Maximum:	112.7 mm (2.30 inches)
Minimum:	23.8 mm (0.94 inches)

← d ⇒ Label Length

Maximum:	depends on SDRAM size
Minimum:	8.0 mm (0.32 inches)

Under ideal circumstances, a minimum label length of 4 mm (0.16 inches) could be used. It requires the sum of the label length (d) and the label gap (e) to be larger than 7 mm (0.28 inches), that batch printing is used, and that no pull back of the media is performed. Intermec does not guarantee that such short labels will work, but it is up to the user to test this in his unique application.

← e ⇒ Label Gap

Maximum:	21.3 mm (0.83 inches)
Recommended:	3.0 mm (0.12 inches)
Minimum:	1.2 mm (0.05 inches)

The Label Stop Sensor must be able to detect the extreme front edges of the labels.

Media Type Setup

- Label (w gaps)

Appendix B—Media Specifications

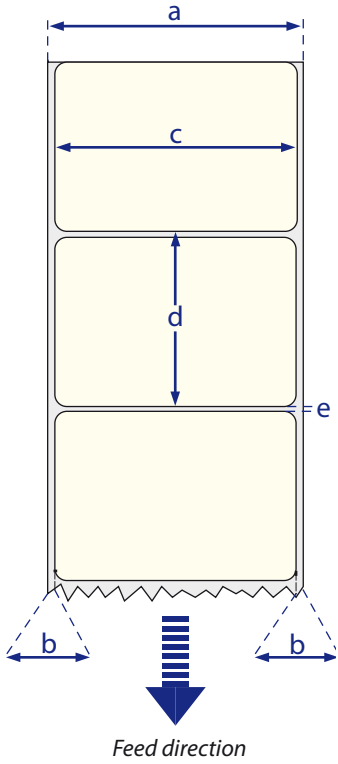

Tickets with Gaps

⇐ a ⇒ Media Width

Maximum:	114.3 mm (4.50 inches)
Minimum:	25.0 mm (1.00 inches)

⇐ b ⇒ Copy Length

Max. length between slots:	depends on SDRAM size
Min. length between slots:	8.0 mm (0.32 inches)

Under ideal circumstances, a minimum ticket length of 4 mm (0.16 inches) could be used. It requires the sum of the copy length (b) and the detection slit height (e) to be larger than 7 mm (0.28 inches), that batch printing is used, and that no pull back of the media is performed. Intermec does not guarantee that such short tickets will work, but it is up to the user to test this in his unique application.

⇐ c ⇒ LSS Detection Position

Variable, see Chapter 12.

⇐ d ⇒ Detection Slit Length

The length of the detection slit (excluding corner radii) must be minimum 2.5 mm (0.10 inches) on either side of the LSS detection position (e).

⇐ e ⇒ Detection Slit Height

Maximum:	21.3 mm (0.83 inches)
Recommended:	1.6 mm (0.06 inches)
Minimum:	1.2 mm (0.05 inches)

Media Type Setup

- Ticket (w gaps)



Note: Do not allow any perforation to break the edge of the media as this may cause the media to split and jam the printer.

Appendix B—Media Specifications

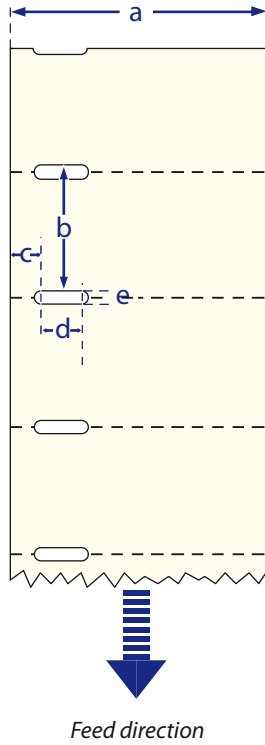

Tickets with Black Mark

⇐ a ⇒ Media Width

Maximum:	114.3 mm (4.50 inches)
Minimum:	25.0 mm (1.00 inches)

⇐ b ⇒ Copy Length

Minimum:	20.0 mm (0.8 inches)
Maximum:	depends on SDRAM size

⇐ c ⇒ LSS Detection Position

Variable, see Chapter 12.

⇐ d ⇒ Black Mark Width

The detectable width of the black mark should be at least 5.0 mm (0.2 inches) on either side of the LSS detection point.

⇐ e ⇒ Black Mark Length

Maximum:	21.3 mm (0.83 inches)
Common:	12.5 mm (0.5 inches)
Minimum:	5.0 mm (0.2 inches)

⇐ f ⇒ Black Mark Y-Position

It is recommended that you place the black mark as close to the front edge of the ticket as possible and use a negative Stop Adjust value to control the media feed, so the tickets can be properly torn off.

Media Type Setup

- Ticket (w mark)





Note: Preprint that may interfere with the detection of the black mark should be avoided. However, the Intermec Fingerprint statement LBLCOND allows the sensor to be temporarily disabled during a specified amount of media feed in order to avoid unintentional detection, see Intermec Fingerprint manuals.

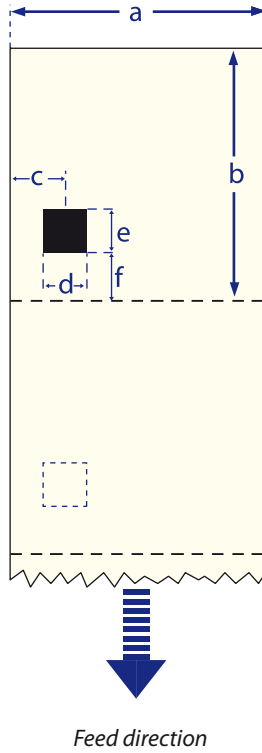

Note: The black mark should be non-reflective carbon black on a whitish background. Do not allow any perforations to break the edge of the media as this may cause the media to split and jam the printer.

Appendix B—Media Specifications





C Interfaces

This appendix describes the interface connectors found on the printer's rear plate. It covers the following topics:

- RS-232 interface
- USB Interface
- Bar Code Wand Interface
- Optional interfaces

RS-232 Interface

Protocol

Default setup:

Baud rate: 9600
Char. length 8 bits
Parity: None
Stop bits: 1
RTS/CTS Disabled
ENQ/ACK: Disabled
XON/XOFF: Disabled (both ways)
New Line: CR/LF

To change the RS-232 interface settings, see Chapter 6, “Setting Up the Printer.”

Signals on printer’s serial port "uart1:"

DB-9	Signal	Meaning
1		External +5V DC*
2	TXD	Transmit data
3	RXD	Receive data
4	DSR	Data set ready
5	GND	Ground
6	DTR	Data terminal ready
7	CTS	Clear to send
8	RTS	Request to send
9	–	Not used

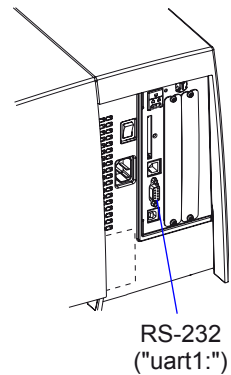

*. The external +5V is limited to 500 mA and is automatically switched off at overload.

Interface Cable

Computer end: Depends on computer model
Printer end: DB-9pin plug

USB Interface

This printer supports USB v1.1 (also called USB 2.0 full speed). To use the USB interface for printing from a PC, you need a special Intermec USB printer driver installed in your PC.

The printer is a so called “self-powered device.” We recommend that you only connect one printer to each USB port on the host, either directly or via a hub. Other devices, like a keyboard and a mouse, can be connected to the same hub. If you need to connect more than one Intermec USB printer to a host, you should use different USB ports.

Using a USB Class A/B cable, connect the Class A plug to your PC or hub and the Class B plug to your printer.

The USB interface is essentially a one-way communication interface and is thus not recommended for programming. There is no communication setup for the USB port.

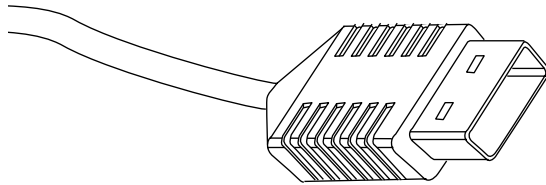

*USB Class A connector.
Connect to PC or hub.*

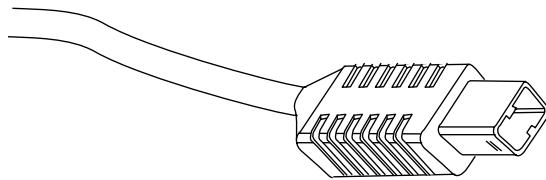

*USB Class B connector.
Connect to USB receptacle on the printer's rear plate.*

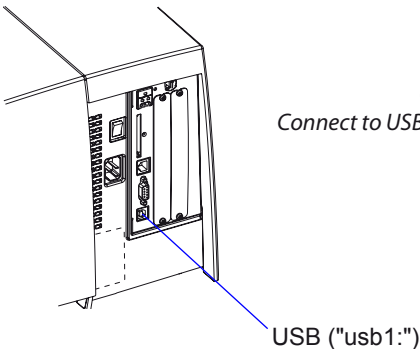

Bar Code Wand Interface

The printer has a socket on the CPU board for connecting a bar code wand or scanner. The socket is accessible through a slot in the printer's rear plate.

If a Code 128 bar code that contains the character FNC3 is read via this port, the data will be treated as a setup string and will change the printer's setup accordingly. A setup bar code may contain a single parameter or a combination of up to 3 or 4 setup parameters. Refer to the *EasySet Bar Code Wand Setup* manual for more information on how to produce setup bar codes.

The printer will acknowledge that a bar code has been successfully read by emitting a short beep signal.

If no FNC3 character is found in the bar code, the data will be stored in a buffer which could be read by specifying the "wand:" device. The buffer is small, so it is recommended to use short bar code data (max. 16 characters) and read the buffer regularly to avoid overflow.

For more demanding applications or for reading bar codes other than Code 128, choose a regular bar code scanner from Intermec's wide product range and connect it to a serial port.

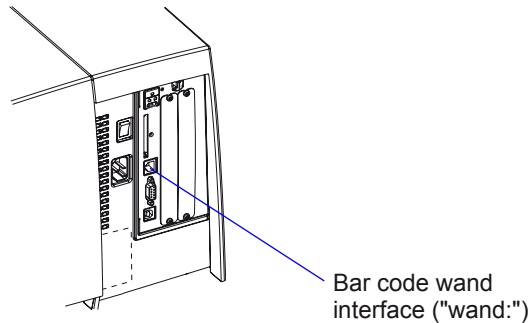

Optional Interfaces

The printer can optionally be fitted with one or two of the following interface boards at the right-hand side of the printer's rear plate:

- Double Serial Interface Board
- Serial/Industrial Interface Board
- IEEE 1284 Parallel Interface Board (only one at a time)
- RFID Option Board (available as spare part only, as part of RFID kit)

Regardless of any of the interface boards mentioned above are installed, the printer can also be fitted with one of the following EasyLAN interface boards for connection to a Local Area Network (LAN):

- EasyLAN Ethernet Interface
- EasyLAN Wireless Interface

Double Serial Interface Board

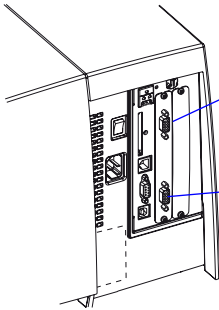

"uart3:"
RS-232,
RS-422 non isolated,
or 20 mA current loop

"uart2:"
RS-232,
RS-422 non isolated,
RS-422 Isolated,
or RS-485

Serial/Industrial Interface Board

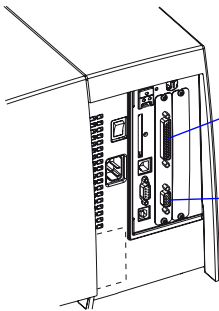

Industrial interface
8 digital In ports
8 digital Out ports
4 relay ports

"uart2:"
RS-232,
RS-422 non isolated,
RS-422 Isolated,
or RS-485

Appendix C—Interfaces

IEEE 1284 Parallel Interface Board

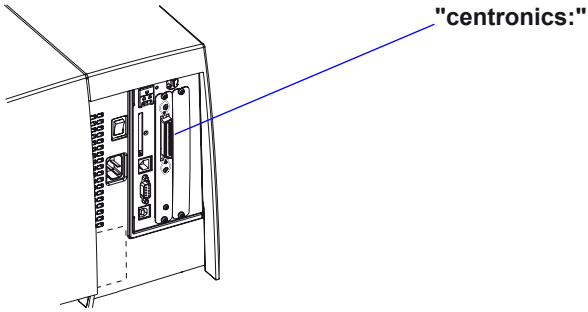

RFID Option Board

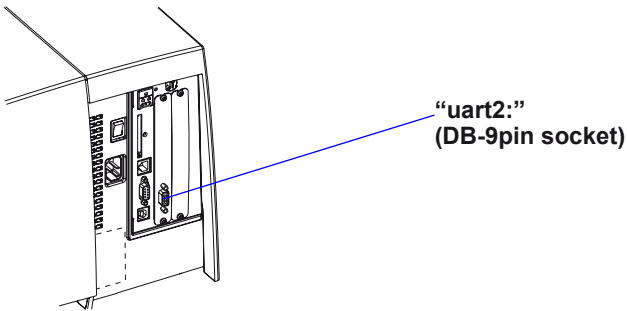

Allowed interface combinations

Allowed interface combinations (Fingerprint)			
Left-hand slot	Ports	Right-hand slot	Ports
Double Serial	uart2: + uart3:	–	–
Double Serial	uart2: + uart3:	IEEE 1284	centronics:
Double Serial	uart2: + uart3:	Double Serial	uart4: + uart5:
Double Serial	uart2: + uart3:	RFID	uart4:
Serial/Industrial	uart2:	–	–
Serial/Industrial	uart2:	Serial/Industrial	uart3:
Serial/Industrial	uart2:	IEEE 1284	centronics:
Serial/Industrial	uart2:	RFID	uart3:
IEEE 1284	centronics	–	–
IEEE 1284	centronics	Double Serial	uart2: + uart3:
IEEE 1284	centronics	Serial/Industrial	uart2:
IEEE 1284	centronics	RFID	uart2:
RFID	uart2:	Double Serial	uart4: + uart5:
RFID	uart2:	IEEE 1284	centronics
RFID	uart2:	Serial/Industrial	uart4:

Remarks:

- The left-hand slot is the slot closest to the center section.
- Always start by fitting an interface board in the left-hand slot.
- RS-485 is only supported by "uart2:"

Appendix C—Interfaces

EasyLAN Ethernet Interface

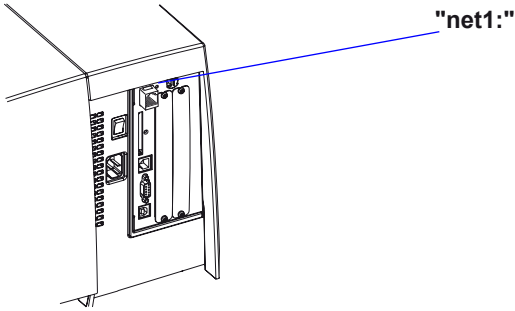

EasyLAN Wireless Interface

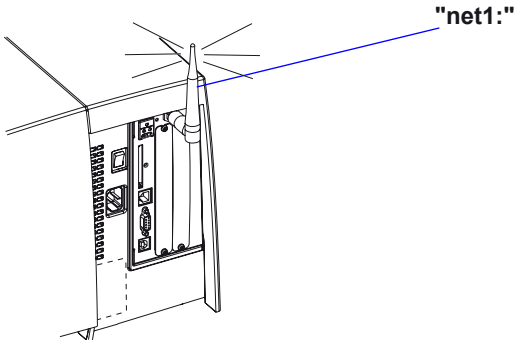



D Intermec Supplies

This appendix describes the supplies offered by Intermec for use with this printer, that is, direct thermal media, thermal transfer ribbons, and receiving face materials for thermal transfer printing

RFID Media

Intermec offers a wide variety of RFID media suitable for different applications. Visit the Intermec website or contact your Intermec representative to find the RFID media best suited to your needs.

Direct Thermal Media

Intermec offers two quality grades of **direct thermal** media for the Easy-Coder printers:

Premium Quality

Top-coated media with high demands on printout quality and resistance against moisture, plasticizers, and vegetable oils. Examples:

Europe

Thermal Top Board
Thermal Top
Thermal Top High Speed

North America

Duratherm II
Duratherm II Tag
Duratherm Lightning
Duratherm Lightning Plus
Duratherm IR

Economy Quality

Non top-coated media with less resistance to moisture, plasticizers, and vegetable oils. In all other respects, it is equal to Premium Quality. Examples:

Europe

Thermal Eco
Thermal Eco Board

North America

—

Thermal Transfer Media

Intermec offers stock labels for thermal transfer printing in a wide range of quality grades.

Uncoated Papers

Economical high-volume printing. To be used with GP/TMX 1100/TMX 1500 ribbons. Examples:

Europe

TTR Uncoated

North America

—

Coated Papers

Various coat-weight, smoothness, and gloss. To be used with HP/TMX 2500 and GP/TMX 1100/TMX 1500 ribbons. Examples:

Europe

TTR Coated

TTR Premium

TTR Premium Board

TTR High Gloss White

North America

Duratron II

Duratron II Tag

Valeron Tag

Polyethylene Plastics

These media have better resistance to water and many common chemicals than uncoated and coated papers. They can be use outdoors and offer good tear resistance. Most often used with HP/TMX 2500 ribbons. Examples:

Europe

TTR Polyethylene

TTR Gloss Polyethylene

North America

Kimdura

Syntran

Polyesters

These media give high resistance to chemicals, heat, and mechanical abrasion with HR/TMX 3200 ribbons. Examples:

Europe

TTR High Gloss Polyester

North America

PET Gloss

Transfer Ribbons

Intermec offer three ranges of thermal transfer ribbons optimized for different purposes:

- **General Purpose (GP/TMX 1500)** transfer ribbons allow high speed printing and give a good printout, but are somewhat sensitive to smearing. They may be the best choice for uncoated and coated papers.
- **High Performance (HP/TMX 2200, TMX 2500)** transfer ribbons allow high speed printing and give a highly readable and defined printout on most face materials with smooth surfaces. They have good “smear resistance” and are most suitable for intricate logotypes and images on matte-coated papers and synthetic face materials.
- **High Resistance (HR/TMX 3200)** transfer ribbons give an extremely durable printout, which is resistant to most chemical agents and high temperatures. However, such transfer ribbons set high demands on the receiving face material, which must be very smooth, such as polyesters.

The use of HR/TMX 3200 ribbons requires the print speed and the energy supplied by the printhead to be controlled with great accuracy according to the receiving face material. Custom-made setup options adapted for special applications can also be created. Consult your Intermec distributor.



Note: Intermec thermal transfer ribbons are engineered specifically for the EasyCoder printheads.

Bar Code Directions

In the tables on the pages that follow, different maximum print speeds may be recommended depending on the direction of possible bar codes in the printout. Generally, ladder style bar codes are more demanding and may require a lower print speed, especially in connection with a large media roll and/or negative start adjust values (see “Print Speed” in Chapter 6). The illustration below shows how the two type of bar code directions relate to the media feed direction.

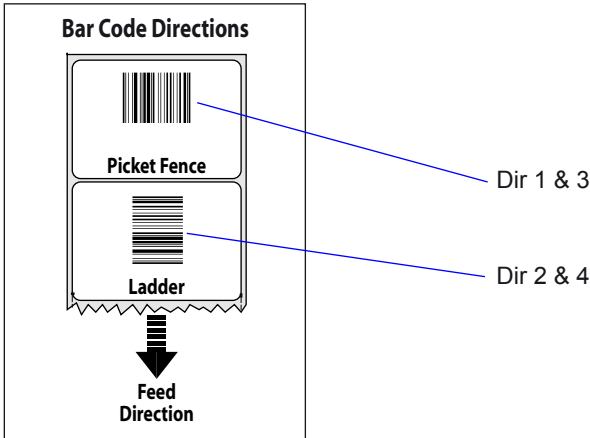

Recommended Paper Type Settings (Europe)

Direct Thermal Printing; 8 dots/mm (203.2 dpi)

Type/Speed	Name	Label Constant	Label Factor	Max Rec. Print Speed ¹	
				Dir 1&3 ²	Dir 2&4 ³
Top Coated/ Standard	Thermal Top Board ⁴	105	40	100	100
	Thermal Top	100	40	200	150
Non Top Coated/ Standard	Thermal Eco	95	40	200	150
	Thermal Eco Board ⁴	85	40	200	150
Top Coated/High	Thermal Top High Speed	90	40	200	200

Thermal Transfer Printing; 8 dots/mm (203.2 dpi)

Type/Speed	Name	Ribbon Constant	Ribbon Factor	Label Offset	Max Rec. Print Speed ¹	
					Dir 1&3 ²	Dir 2&4 ³
GP02	TTR Uncoated	75	25	0	150	150
	TTR Coated	80	25	0	150	150
	TTR Premium	70	25	0	200	200
HP66	TTR Coated	100	25	0	200	200
	TTR Premium	80	25	0	200	200
	TTR Premium Board ⁴	105	25	0	150	150
	TTR High Gloss White	95	25	0	200	200
	TTR Polyethylene	75	25	0	200	150
	TTR Gloss Polyethylene	90	25	0	200	200
HP07	TTR Coated	100	25	0	200	200
	TTR Premium	90	25	0	200	200
	TTR Premium Board ⁴	105	25	0	150	150
	TTR Polyethylene	85	25	0	200	200
	TTR Gloss Polyethylene	95	25	0	200	150
HP05	TTR Coated	100	25	0	200	200
	TTR Premium	80	25	0	200	200
	TTR Premium Board ⁴	95	25	0	200	200
	TTR High Gloss White	80	25	0	200	200
	TTR Polyethylene	75	25	0	200	150
	TTR Gloss Polyethylene	80	25	0	200	200
HR03	TTR High Gloss Polyester	100	30	0	200	200

^{1/}. Exceeding the recommended print speed may cause the printhead to wear out prematurely. If the ambient temperature is lower than +15°C (+59°F), decrease print speed by 50 mm/sec.

^{2/}. Applies to printing of text, lines, boxes, images, and picket fence bar codes.

^{3/}. Applies to ladder bar codes.

^{4/}. Requires high printhead pressure (see Chapter 12 “Adjustments, Printhead Pressure”).

Direct Thermal Printing; 11.81 dots/mm (300 dpi)

Type/Speed	Name	Label Constant	Label Factor	Max Rec. Print Speed ¹ Dir 1&3 ²	Dir 2&4 ³
Top Coated/ Standard	Thermal Top Board ⁴	105	40	100	100
	Thermal Top	95	40	150	150
Non Top Coated/ Standard	Thermal Eco	90	40	150	150
	Thermal Eco Board ⁴	75	40	150	150
Top Coated/High	Thermal Top High Speed	80	40	150	150

Thermal Transfer Printing; 11.81 dots/mm (300 dpi)

Type/Speed	Name	Ribbon Constant	Ribbon Factor	Label Offset	Max Rec. Print Speed ¹ Dir 1&3 ²	Dir 2&4 ³
GP02	TTR Uncoated	80	25	0	150	125
	TTR Coated	90	25	0	150	125
	TTR Premium	70	25	0	150	125
HP66	TTR Coated	100	25	0	150	150
	TTR Premium	85	25	0	150	150
	TTR Premium Board ⁴	105	25	0	100	150
	TTR High Gloss White	95	25	0	150	150
	TTR Polyethylene	90	25	0	150	150
HP07	TTR Coated	105	25	0	150	125
	TTR Premium	95	25	0	150	150
	TTR Premium Board ⁴	105	25	0	150	100
	TTR Polyethylene	100	25	0	150	150
	TTR Gloss Polyethylene	100	25	0	150	150
HP05	TTR Coated	100	25	0	150	125
	TTR Premium	85	25	0	150	150
	TTR Premium Board ⁴	95	25	0	150	150
	TTR High Gloss White	80	25	0	150	150
	TTR Polyethylene	85	25	0	150	150
	TTR Gloss Polyethylene	80	25	0	150	150
HR03	TTR High Gloss Polyester	100	30	0	150	150

^{1/}. Exceeding the recommended print speed may cause the printhead to wear out prematurely. If the ambient temperature is lower than +15°C (+59°F), decrease print speed by 50 mm/sec.

^{2/}. Applies to printing of text, lines, boxes, images, and picket fence bar codes.

^{3/}. Applies to ladder bar codes.

^{4/}. Requires high printhead pressure (see Chapter 12 “Adjustments, Printhead Pressure”).

Recommended Paper Type Settings (North America)

Direct Thermal Printing; 8 dots/mm (203.2 dpi)

Type/Speed	Name	Label	Label	Max Rec. Print Speed ¹	
		Constant	Factor	Dir 1&3 ²	Dir 2&4 ³
Top Coated/ Standard	Duratherm II	96	40	200	200
	Duratherm II Tag ⁴	115	40	200	100
Top Coated/ High	Duratherm Lightning	92	40	200	200
	Duratherm Ltg. Plus	85	40	200	200
	Duratherm IR	84	40	200	150

Thermal Transfer Printing; 8 dots/mm (203.2 dpi)

Type/Speed	Name	Ribbon	Ribbon	Label	Max Rec. Print Speed ¹	
		Constant	Factor	Offset	Dir 1&3 ²	Dir 2&4 ³
TMX 1500	Duratron II	64	25	0	200	200
	Syntran	65	25	0	200	200
	Kimdura	73	25	0	200	200
	Valeron Tag	80	25	0	200	200
	Duratron II Tag	74	25	0	200	200
TMX 2200	Duratron II	64	25	0	200	200
	Kimdura	80	25	0	200	200
	Valeron Tag	83	25	0	200	200
	Duratron II Tag	75	25	0	200	200
TMX 2500	Duratron II	67	25	0	200	200
	Syntran	84	25	0	100	100
	Kimdura	82	25	0	200	200
	Valeron Tag	95	25	0	200	200
	Duratron II Tag	76	25	0	200	200
TMX 3200	PET Gloss	93	30	0	200	200

^{1/}. Exceeding the recommended print speed may cause the printhead to wear out prematurely. If the ambient temperature is lower than +15°C (+59°F), decrease print speed by 50 mm/sec.

^{2/}. Applies to printing of text, lines, boxes, images, and picket fence bar codes.

^{3/}. Applies to ladder bar codes.

Direct Thermal Printing; 11.81 dots/mm (300 dpi)

Type/Speed	Name	Label	Label	Max Rec. Print Speed ¹	
		Constant	Factor	Dir 1&3 ²	Dir 2&4 ³
Top Coated/ Standard	Duratherm II	93	40	150	150
	Duratherm II Tag ⁴	112	40	150	100
Top Coated/ High	Duratherm Lightning	85	40	150	150
	Duratherm Ltg. Plus	80	40	150	150
	Duratherm IR	82	40	150	150

Thermal Transfer Printing; 11.81 dots/mm (300 dpi)

Type/Speed	Name	Ribbon	Ribbon	Label	Max Rec. Print Speed ¹	
		Constant	Factor	Offset	Dir 1&3 ²	Dir 2&4 ³
TMX 1500	Duratron II	65	25	0	150	150
	Syntran	65	25	0	150	150
	Kimdura	76	25	0	150	150
	Valeron Tag	80	25	0	150	150
	Duratron II Tag	74	25	0	150	150
TMX 2200	Duratron II	65	25	0	150	150
	Kimdura	80	25	0	150	150
	Valeron Tag	84	25	0	150	150
	Duratron II Tag	75	25	0	150	150
TMX 2500	Duratron II	66	25	0	150	150
	Syntran	85	25	0	150	150
	Kimdura	80	25	0	150	150
	Valeron Tag	105	25	0	150	150
	Duratron II Tag	77	25	0	150	150
TMX 3200	PET Gloss	93	30	0	150	150

^{1/}. Exceeding the recommended print speed may cause the printhead to wear out prematurely. If the ambient temperature is lower than +15°C (+59°F), decrease print speed by 50 mm/sec.

^{2/}. Applies to printing of text, lines, boxes, images, and picket fence bar codes.

^{3/}. Applies to ladder bar codes.



E Setup Mode Overviews

This appendix provides overviews of the parameters and messages available for the standard printer and with various interface boards.

Setup Mode; Serial Communication "uart1:"

(Intermec Fingerprint v8.70)

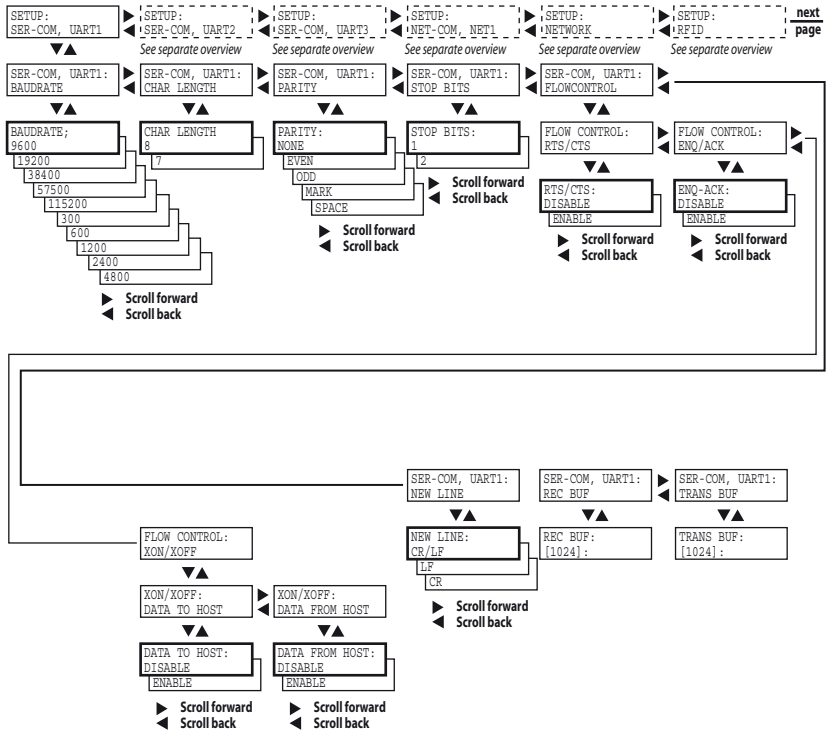

Legend:

Dotted boxes and lines indicate options.

Thick boxes indicates default options.

Values inside brackets indicate default settings.

Setup Mode; Feed Adjust

(Intermec Fingerprint v8.70)

Continued from the previous page

SETUP:
FEEDADJ



FEEDADJ:
STARTADJ



STARTADJ:
[0]:



FEEDADJ:
STOPADJ



STOPADJ:
[0]:

Continued on the next page

Setup Mode; Media

(Intermec Fingerprint v8.70)

Continued from the previous page Continued on the next page

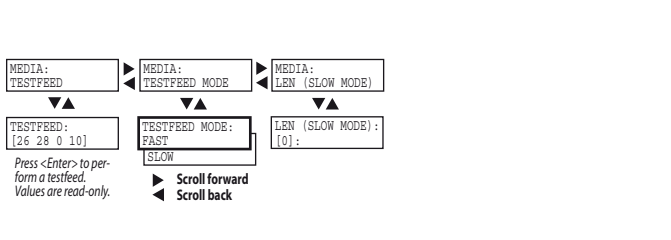
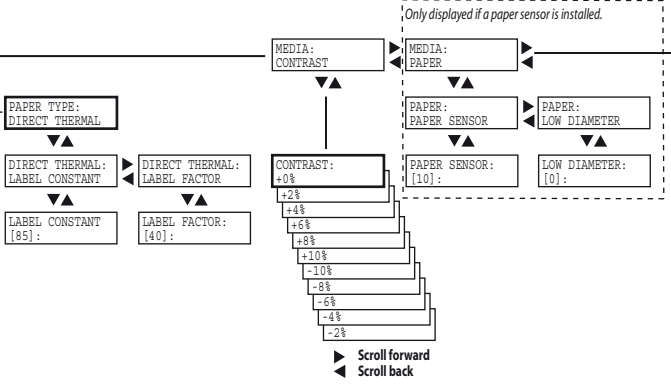
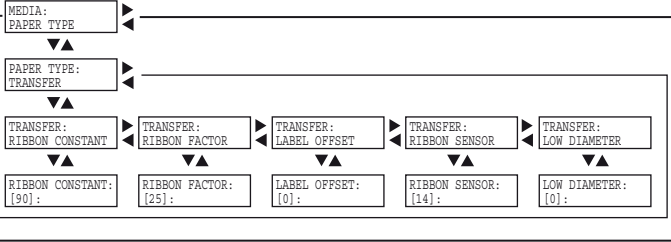
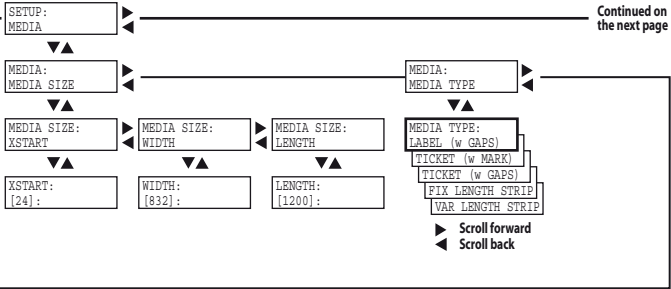

Setup Mode; Print Defs

(Intermec Fingerprint v8.70)

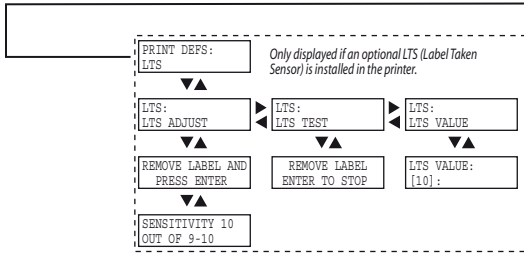
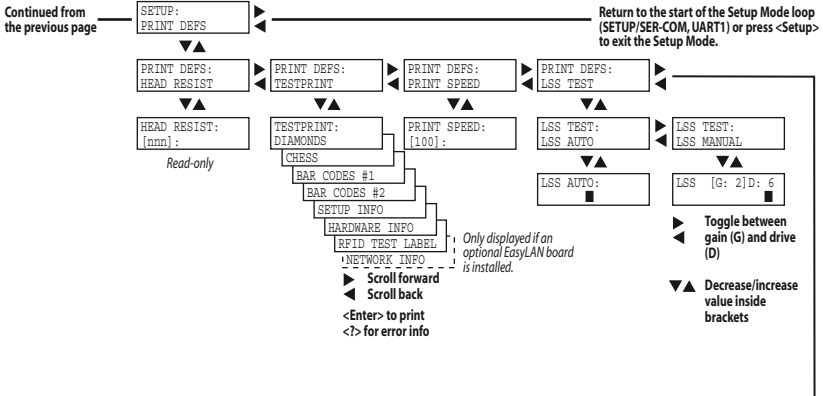

Setup Mode; Serial Communication "uart2:" (option)

(Intermec Fingerprint v8.70)

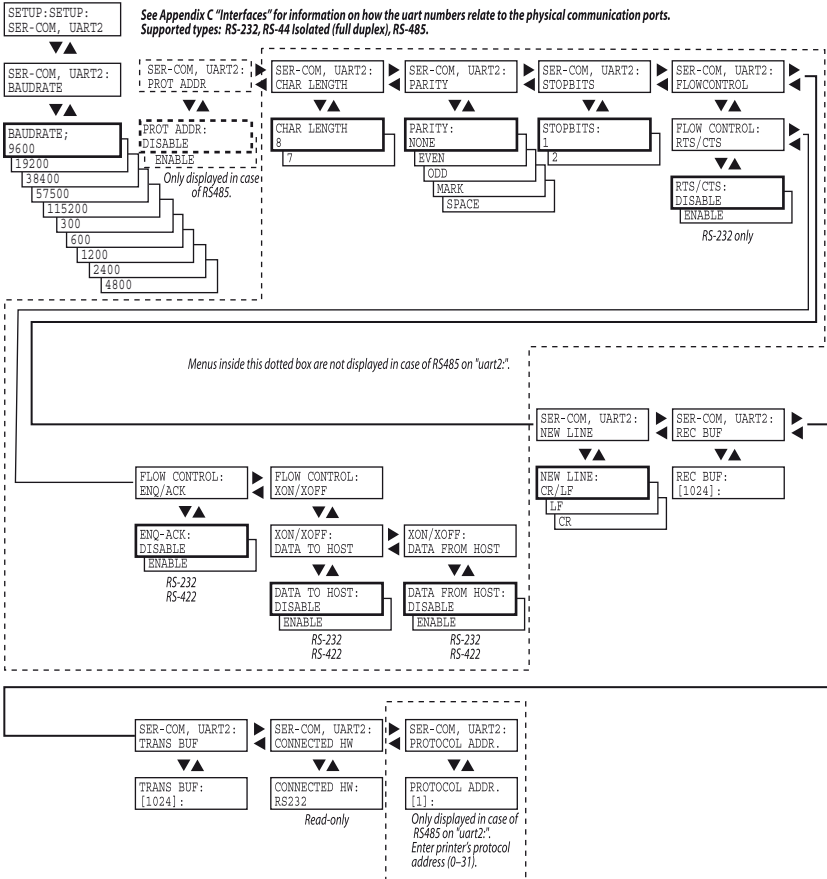

Setup Mode; Serial Communication "uart3:" (option)

(Intermec Fingerprint v8.70)

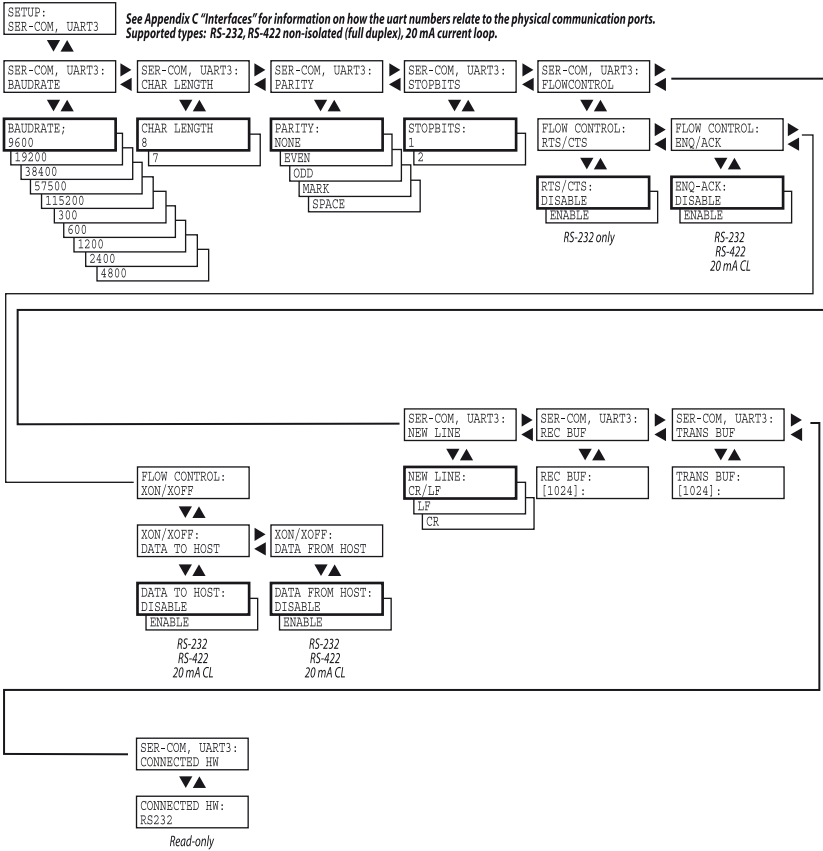

Setup Mode; Serial Communication "uart4:" (option) (Intermec Fingerprint v8.70)

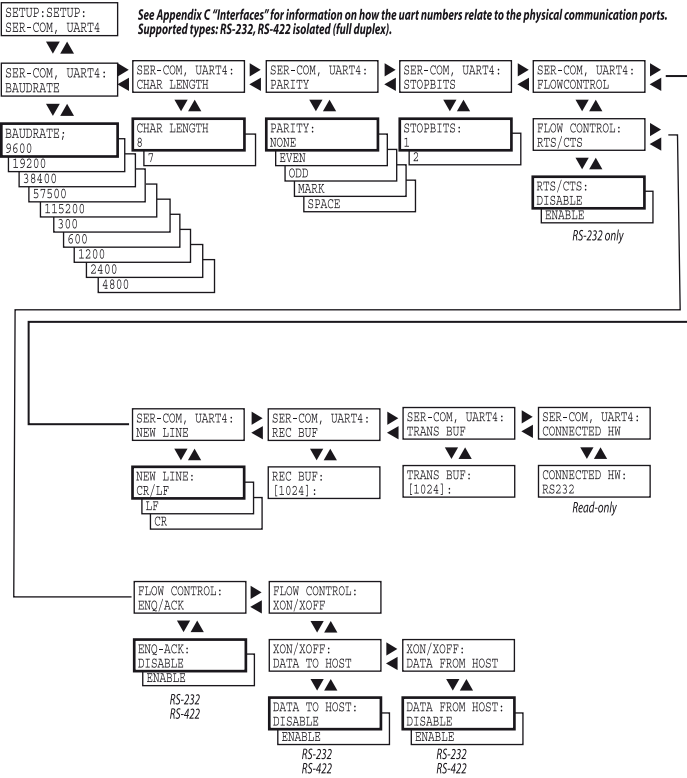

Setup Mode; Serial Communication "uart5:" (option) (Intermec Fingerprint v8.70)

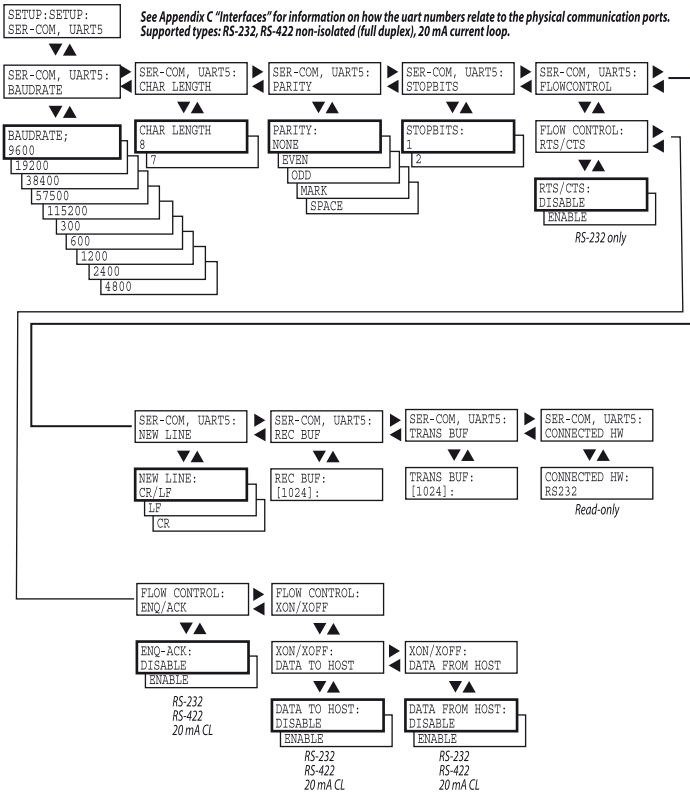

Setup Mode; Network Communication "net1:" (option) (Intermec Fingerprint v8.70)

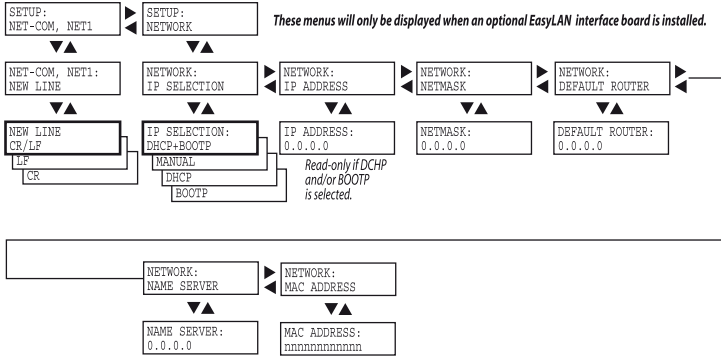

Setup Mode; RFID (option)

(Intermec Fingerprint v8.70)

Continued from the previous page

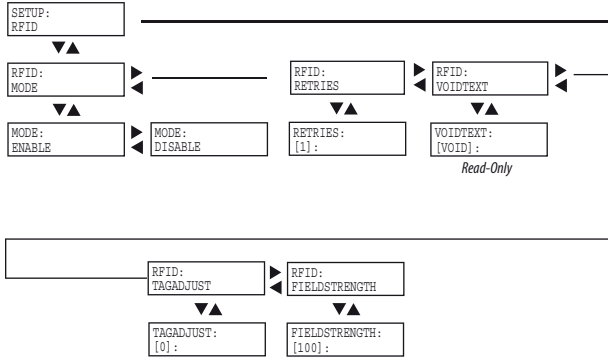

Continued on the next page



Intermec Technologies Corporation

Corporate Headquarters
6001 36th Avenue West
Everett, WA 98203
U.S.A.

tel +425.348.2600

fax +425.355.9551

www.intermec.com

EasyCoder PM4i—User's Guide (Fingerprint version)



P/N 1-960583-04