

# HP xw9400 Workstation Service and Technical Reference Guide



**Copyright Information**

© 2008-2009 Copyright Hewlett-Packard Development Company, L.P.

**Warranty**

Hewlett-Packard Company shall not be liable for technical or editorial errors or omissions contained herein or for incidental or consequential damages in connection with the furnishing, performance, or use of this material. The information in this document is provided "as is" without warranty of any kind, including, but not limited to, the implied warranties of merchantability and fitness for a particular purpose, and is subject to change without notice. The warranties for HP products are set forth in the express limited warranty statements accompanying such products.

Nothing herein should be construed as constituting and additional warranty.

This document contains proprietary information that is protected by copyright. No part of this document may be photocopied, reproduced, or translated to another language without the prior written consent of Hewlett-Packard Company.

**Trademark Credits**

The HP Invent logo is a trademark of Hewlett-Packard Company in the U.S. and other countries.

Microsoft and Windows are trademarks of Microsoft Corporation.

UNIX is a registered trademark of The Open Group.

Intel and Xeon are registered trademarks of Intel Corporation in the U.S. and other countries.

Energy Star is U.S. registered mark of the United States Environmental Protection Agency.

434615-009

Ninth Edition, June 2009

---

# Table of contents

## 1 Product overview

Product features .....	1
Exploded view .....	1
Front panel components .....	3
Rear panel components .....	4
Serial number and COA label location .....	4
Product specifications .....	5
Power supply and cooling .....	6
Power supply specifications .....	8
Power consumption and heat dissipation .....	8
System fans and airflow .....	9
Resetting the power supply .....	9
Power cord requirements .....	9
Environmental specifications .....	10
PCI card slot power specification .....	10
Chipkill support .....	11
ENERGY STAR Qualification .....	11
Multi-core processors .....	12

## 2 Setting up the operating system

Setting up the Microsoft operating system .....	14
Installing or upgrading device drivers .....	14
Transferring files and settings to your Windows workstation .....	14
Setting up Red Hat Enterprise Linux .....	15
Installing with the HP driver CD .....	15
Installing and customizing Red Hat-enabled workstations .....	16
Verifying hardware compatibility .....	16
Setting up Novell SLED .....	16
Updating the workstation .....	16
Updating the workstation after first boot .....	16
Upgrading the BIOS .....	16
Determining current BIOS .....	17
Upgrading BIOS .....	18
Upgrading device drivers .....	18

## 3 Restoring the operating system

Restore methods .....	19
Ordering backup software .....	20

Restoring Windows Vista .....	20
Ordering the RestorePlus! media .....	20
Restoring the operating system .....	20
Restoring Windows XP Professional .....	21
Creating RestorePlus! media .....	21
Creating HP Backup and Recovery (HPBR) media .....	22
Restoring the operating system .....	23
Using RestorePlus! .....	23
Using HPBR .....	23
Using the recovery partition .....	23
Restoring Novell SLED .....	23
Creating restore media .....	23

## 4 System management

Computer Setup (F10) Utility .....	25
BIOS ROM .....	26
Using Computer Setup (F10) Utility .....	27
Computer Setup (F10) Utility menu .....	28
Desktop management .....	36
Initial configuration and deployment .....	36
Remote system installation .....	37
Managing and updating software .....	37
HP Client Manager software .....	37
Altiris Client Management solutions .....	38
System Software Manager .....	38
Proactive Change Notification .....	39
Subscriber's Choice .....	39
ROM flash .....	39
Remote ROM flash .....	39
HPQFlash .....	39
FailSafe Boot Block ROM .....	40
Replicating the setup .....	41
Copying to a single workstation .....	41
Copying to multiple workstations .....	41
Dual-state power button .....	42
Worldwide web site .....	43
Building blocks and partners .....	43
Asset tracking and security .....	43
Password security .....	44
Establishing a setup password in the Computer Setup (F10) Utility .....	45
Establishing a power-on password in the Computer Setup (F10) Utility .....	45
Entering a power-on password .....	46



Entering a setup password .....	46
Changing a power-on or setup password .....	46
Deleting a power-on or setup password .....	47
National keyboard delimiter characters .....	47
Clearing passwords .....	47
Hood sensor (Smart Cover Sensor) .....	48
Setting the hood sensor protection level .....	48
Cable lock provision (optional) .....	48
Security lock (optional) .....	48
Universal chassis clamp lock (optional) .....	48
Access panel key lock .....	49
Fault notification and recovery .....	49
Drive Protection System .....	49
ECC fault prediction and pre-failure warranty .....	49
Thermal sensors .....	49

## 5 Removal and replacement procedures

Warnings and cautions .....	50
Service considerations .....	51
Read cautions, warnings, and safety precautions .....	51
Electrostatic discharge information .....	51
Generating static .....	52
Preventing electrostatic damage to equipment .....	52
Personal grounding methods and equipment .....	53
Grounding the work area .....	53
Recommended materials and equipment .....	53
Required tools and software .....	54
Screws .....	54
Special handling of components .....	54
Cables and connectors .....	54
Hard drives .....	54
Lithium coin cell battery .....	55
Customer Self Repair .....	55
Pre-disassembly procedures .....	55
System board components .....	56
System board architecture .....	57
Removing and replacing components .....	58
Disassembly order .....	59
Security lock (optional) .....	61
Cable lock (optional) .....	61
Universal chassis clamp lock (optional) .....	62
Access panel .....	63
Front bezel .....	64

Bezel blanks .....	64
Hood sensor (Smart cover sensor) .....	65
Front panel I/O device assembly .....	66
Power button assembly and system speaker .....	67
Power supply .....	69
System fan .....	70
Memory fan .....	71
Memory .....	72
Memory module features .....	72
Memory module requirements .....	72
Removing memory module .....	73
Installing a memory module .....	75
PCI slots .....	77
PCI retainer .....	78
Removing the PCI retainer .....	78
Installing the PCI retainer .....	78
PCI retention clamp .....	80
PCI Express .....	81
Removing PCI or PCI Express cards .....	82
PCI or PCI Express installation .....	83
Front fan removal .....	84
Front fan jumper cable installation .....	86
Battery .....	88
Power connections to drives .....	89
Optical drive .....	90
Replacing the SATA optical drive data cable .....	92
Notice for Blu-ray optical drives .....	92
Blu-ray movie playback .....	92
Blu-ray movie playback compatibility and update .....	92
Diskette drive (optional) .....	93
Hard drive .....	95
Replacing a hard drive .....	95
Removing a hard drive .....	95
Installing a hard drive .....	96
Installing a hard drive in the fifth hard drive bay .....	98
Liquid cooling unit .....	99
Removing the liquid cooling unit .....	99
Installing a liquid cooling unit .....	103
Replacing the liquid cooling unit VRD fan .....	110
Removing the VRD fan .....	110
Installing the VRD fan .....	111
Processor heatsink .....	113
Removing the CPU heatsink .....	113
Replacing the CPU heatsink .....	115

Processor .....	117
Removing the processor .....	117
Replacing the processor .....	119
System board .....	120
Removing the system board .....	120
Replacing the System Board .....	120
Product recycling .....	121

## 6 System diagnostics and troubleshooting

HP troubleshooting resources and tools .....	122
HP Help and Support Center .....	122
E-support .....	122
Troubleshooting a problem .....	123
Instant Support and Active Chat .....	123
Customer Advisories, Customer and Security Bulletins, and Customer Notices .....	123
Product Change Notifications .....	123
Helpful hints .....	124
At startup .....	124
During operation .....	124
Customizing the monitor display .....	125
Troubleshooting checklist .....	125
LED color definitions .....	125
Self-troubleshooting with HP Vision Field Diagnostics .....	126
Overview .....	126
Downloading and accessing HP Vision Field Diagnostics .....	127
User interface .....	128
Survey tab .....	128
Test tab .....	130
Status tab .....	132
History tab .....	132
Errors tab .....	132
Help tab .....	133
Saving and printing information in HP Vision Field Diagnostics .....	134
Downloading the latest diagnostic utility .....	134
Diagnostic error codes .....	134
Diagnostic light codes .....	134
Troubleshooting scenarios and solutions .....	137
Solving minor problems .....	137
Solving power supply problems .....	140
Testing power supply .....	140
Solving diskette problems .....	142
Solving hard drive problems .....	143
Solving display problems .....	145

Solving audio problems .....	148
Solving printer problems .....	149
Solving keyboard and mouse problems .....	150
Solving front panel component problems .....	151
Solving hardware installation problems .....	151
Solving network problems .....	153
Solving memory problems .....	155
Solving processor problems .....	156
Solving CD-ROM and DVD problems .....	157
Solving Internet access problems .....	158
POST error messages .....	160

#### **Appendix A Appendix A — SAS devices**

Supported SAS RAID configurations .....	168
SAS RAID 0 (IS) configuration .....	168
SAS RAID 1 (IM) configuration .....	169
SAS RAID 1E (IME) configuration .....	170
Changing boot order .....	171

#### **Appendix B Appendix B—SATA devices**

Enable SATA RAID option in BIOS .....	172
Configuring a SATA RAID array .....	172
Changing boot order .....	173
Deleting RAID volumes .....	174

#### **Appendix C Appendix C— Connector pins**

Connector pin descriptions .....	175
----------------------------------	-----

#### **Appendix D Appendix D— System board designators**

#### **Appendix E Appendix E— Power cord set requirements**

#### **Appendix F Appendix F— Routine care**

General cleaning safety precautions .....	187
Maximizing the airflow .....	187
Cleaning the workstation case .....	187
Cleaning the keyboard .....	188
Cleaning the monitor .....	188
Cleaning the mouse .....	188

#### **Appendix G Appendix G— Additional password security and resetting CMOS**

Resetting the password jumper .....	189
-------------------------------------	-----

Clearing and resetting the CMOS .....	190
Using the CMOS button .....	190
Using the Computer Setup Utility to reset CMOS .....	190

#### **Appendix H Appendix H— Quick troubleshooting flowcharts**

Initial troubleshooting .....	192
No power .....	192
No power, part 1 .....	193
No power, part 2 .....	194
No power, part 3 .....	194
No video .....	195
No video, part 1 .....	196
No video, part 2 .....	196
No video, part 3 .....	197
Error messages .....	198
Error messages, part 1 .....	199
Error messages, part 2 .....	199
No operating system loading .....	200
No operating system loading from hard drive .....	201
No operating loading from hard drive, part 1 .....	202
No operating system loading from hard drive, part 2 .....	202
No operating system loading from hard drive, part 3 .....	203
No operating system loading from diskette drive .....	204
No operating system loading from optical drive .....	205
No operating system loading from network .....	206
Non-functioning device .....	207

#### **Appendix I Appendix I—PCI bus layout**

PCI bus layout and device list .....	209
--------------------------------------	-----

#### **Appendix J Appendix J— Configuring SATA and PATA optical disk drives**

Drive detection and assignment sequence .....	211
Workstation SATA port configuration rules .....	211
HP w9400 Workstation BIOS configuration .....	211
HP xw8400/xw6400/xw4400 Workstation SATA configuration mode settings .....	211



# 1 Product overview

This chapter presents an overview of the hardware components of the HP Workstation.

- [Product features on page 1](#)
- [Product specifications on page 5](#)
- [Chipkill support on page 11](#)
- [ENERGY STAR Qualification on page 11](#)
- [Multi-core processors on page 12](#)

## Product features

### Exploded view

The following image shows a typical HP xw9400 Workstation (drive configurations can vary).

For complete and current information on supported accessories and components, see <http://partsurfer.hp.com>.

**Figure 1-1** Exploded view

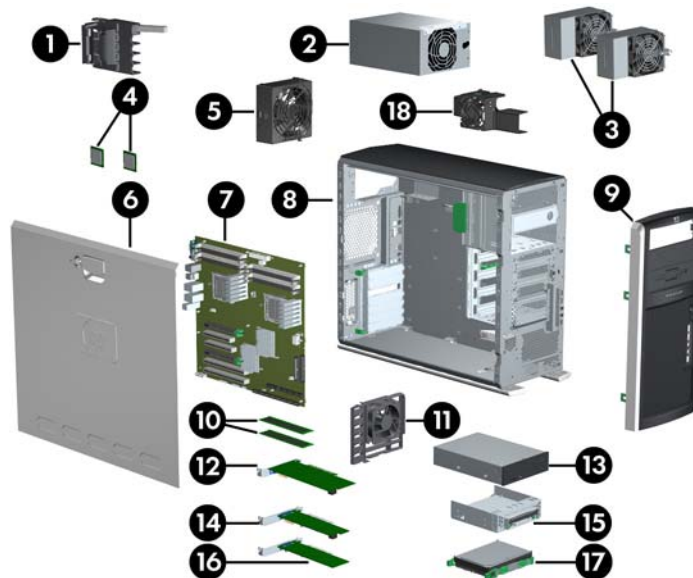

**Table 1-1** Exploded view

Item	Description	Item	Description
1	PCI card support	10	Memory modules
2	Power supply	11	Card guide/Front fan
3	CPU heatsinks	12	Graphics card
4	Processors	13	Optical drive*

**Table 1-1 Exploded view (continued)**

<b>Item</b>	<b>Description</b>	<b>Item</b>	<b>Description</b>
<b>5</b>	System fan	<b>14</b>	PCIe card
<b>6</b>	Access panel	<b>15</b>	Diskette drive
<b>7</b>	System board	<b>16</b>	PCI card
<b>8</b>	Chassis	<b>17</b>	Hard drive
<b>9</b>	Front bezel	<b>18</b>	Memory fan

\* A CD-ROM is an example of an optical drive.







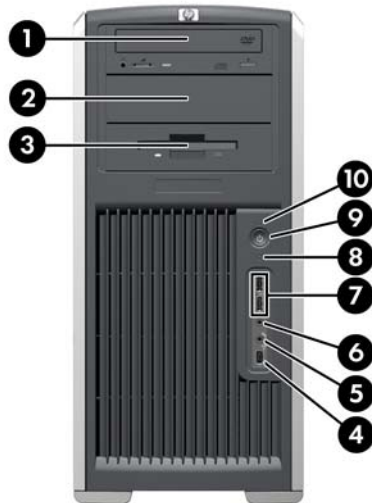

## Front panel components

The following image shows a typical HP xw9400 Workstation. Drive configurations can vary.

**Figure 1-2** Front panel components



**Table 1-2** Front panel components

Item	Symb ol	Description	Item	Symb ol	Description
1		Optical drive	6		Headphone connector
2		5.25-inch drive bay	7		USB 2.0 ports
3		Diskette drive (optional)	8		Hard drive activity light
4		IEEE-1394a connector	9		Power button
5		Microphone connector	10		Power on light

## Rear panel components

Figure 1-3 Rear panel components

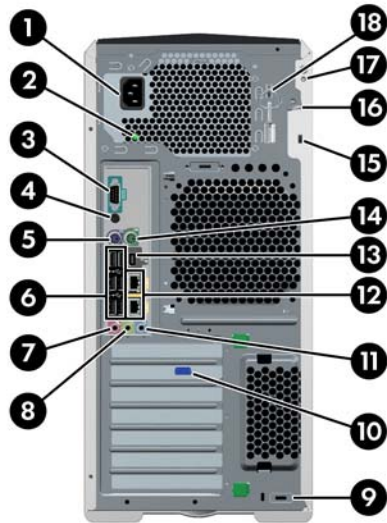

Table 1-3 Rear panel components

Item	Symbol*	Description	Item	Symbol	Description
1		Power cord connector	10		Graphics adapter
2		Built In Self Test (BIST) LED	11		Audio line-in connector
3		Serial connector	12		RJ-45 network connectors
4		SPDIF OUT**	13		IEEE-1394a connector
5		Keyboard connector	14		Mouse connector
6		USB 2.0 ports	15		Cable lock slot
7		Microphone connector	16		Padlock loop
8		Audio line-out connector	17		Universal chassis clamp opening
9		MiniSAS 4-port connector (optional)	18		Access panel key

\* The rear panel connectors are labeled with industry-standard icons and colors to assist you in connecting your peripheral devices.

\*\* SPDIF OUT is a single RCA jack to support SPDIF digital audio output via coax cable.

## Serial number and COA label location

Each workstation has two unique serial number labels. Systems preinstalled with Microsoft® Windows® XP also have a certificate of authentication (COA) label (2). The serial number labels (1) are located on

the side panel of the unit and on the rear panel. Keep the serial number available when contacting customer service for assistance.

**Figure 1-4** Serial number and COA label location



## Product specifications

The following table lists the physical dimensions.

**Table 1-4 Physical characteristics**

Weight (depending on configuration)	18-27.7 kg (39.6-61.1 lb.)
Tower dimensions	455 mm (17.9 in.) tall, 210 mm (8.3 in.) wide, 525 mm (20.7 in.) deep
Rack mount dimensions (top cover and foot removed)	210 mm (8.3 in.) tall, 440 mm (17.3 in.) wide, 525 mm (20.7 in.) deep

## Power supply and cooling

This section describes power supply specifications.

**Table 1-5 Power supply source voltages**

Source voltage	Description
+3.3V	PCI, PCIe, onboard logic, SAS controller, IEEE 1394, and chipset
+5V	Storage (disk, optical, diskette), PCI, audio, USB, input to onboard regulator, and onboard logic
+12 V-CPU0	Input to onboard regulator that supplies power to CPU0 and CPU0 fan
+12 V-CPU1	Input to onboard regulator that supplies power to CPU1, CPU1 fan, and chipset regulators
+12 V-M	Input to onboard regulator that supplies power to memory
+12 V-B	PCI, PCIe, and system fans
+12 V-D	Storage (hard drive, optical drive, diskette drive)
+12 V/G1	PCI Express auxiliary connector
+12 V-G2	Second PCI Express auxiliary connector
+12 V-R	Not used
+12 V-N	PCI and serial ports
+5 V-SB	Sleep circuitry

**Table 1-6 Maximum current per rail**

Voltage rail	1050W maximum continuous current
+3.3V	22.0A
+5V	18.0A
+12 V-CPU0	18.0A
+12 V-CPU1	18.0A
+12 V-M	18.0A
+12 V-B	18.0A
+12 V-D	18.0A
+12 V/G1	18.0A
+12 V-G2	18.0A
+12 V-R	18.0A
+12 V-N	0.30A
+5 V-SB	9.0A

---

△ **CAUTION:** Do not exceed 150 watts of 3.3V and 5V power combination.

Do not exceed 84.0 amps (1008W) of 12V (CPU0/CPU1/M/B/D/G1/G2/R) power combination.

Do not exceed 1050 watts of total continuous output power.

---

## Power supply specifications

The integrated, surge-tolerant power supply is rated to withstand a power surge of up to 2,000 V (line-to-PE or neutral-to-PE) and 1,000 V (line-to-line) without any data loss or system downtime. The following specifications describe the power supply:

**Table 1-7 Power supply specifications**

Item	Description	
Power supply	<b>1050W</b> Wide Ranging, Active PFC	
Operating voltage range	<b>90-269 VAC</b>	
Rated voltage range	<b>100-240 VAC</b>	<b>118 VAC</b>
Rated line frequency	50-60 Hz	400 Hz
Operating line frequency range	47-66 Hz	393-407 Hz
Rated input current	13.2A @ 100-127 VAC 6.6A @ 200-240 VAC	12.0A @ 118 VAC
Heat dissipation (Configuration and software dependent)	Typical 3,136 BTU/hr = 791kg-cal/hr) Maximum 4,480 BTU/hr = 1,129 kg-cal/hr)	
Power supply fan	92x32 mm variable speed	
80 Plus compliant	80 Plus compliant and compatible with ENERGY STAR compliant configurations.	
FEMP Standby Power compliant @115V (<2W in S5 – Power Off)	No	
Power Consumption in ENERGY STAR Mode – Suspend to RAM (S3) (Instantly Available PC)	<25 watts	
Built-in self-test LED	Yes	
Surge tolerant (withstands power surges up to 2000V)	Yes	

## Power consumption and heat dissipation

Power consumption and heat dissipation specifications are available for multiple power supply configurations. To review available specifications, see <http://www.hp.com/go/quickspecs>.

To reach zero power consumption, unplug the workstation from the power outlet or use a power strip with an on/off switch. For additional information about power-saving features, see your operating system documentation.

This product is in compliance with U.S. Executive Order 13221.

## System fans and airflow

The workstation includes one rear system fan, one memory fan, one processor (CPU) heatsink fan for each processor, and one power supply fan, plus a front system fan.

## Resetting the power supply

If an overload triggers the power supply overload protection, all power is immediately shut off. To reset the power supply unit:

1. Disconnect the power cord.
2. Determine what caused the overload and fix the problem.
3. Reconnect the power cord and reboot the workstation.

When you power down the workstation through the operating system, power consumption falls below the low power consumption rate but does not reach zero. This on/off feature extends the life of the power supply.

## Power cord requirements

The power cord set (flexible cord or wall plug) received with this product meets the requirements for use in the country where you purchased the equipment.

If you must obtain a power cord for a different country, you should purchase a power cord that is approved for use in that country.

The power cord must be rated for the product and for the voltage and current marked on the product's electrical ratings label. The voltage and current rating of the cord should be greater than the voltage and current rating marked on the product. The length of the cord must be between 1.8m (6 feet) and 3.6m (12 feet). If you have questions about the type of power cord to use, contact the HP authorized service provider.

A power cord should be routed so that it is not likely to be walked on or pinched by items placed on it or against it. Particular attention should be paid to the plug, electrical outlet, and the point where the cord exits from the product.

---

 **NOTE:** A 15AMP-capable (minimum) power cord must be used in with a 110-V power source. A 10AMP-capable (minimum) power cord should be used with a 220-V power source.

---

## Environmental specifications

This section describes environmental specifications of your workstation.

<b>Temperature</b>	<p><b>Operating:</b> 5 to 35°C (40 to 95°F)</p> <p><b>Non-operating:</b> -40 to 60°C (-40 to 140°F)</p> <p><b>NOTE:</b> Derate by one degree C (1.4 degrees F) for every 305m (1,000 ft.) altitude over 1,524m (5,000 ft.).</p>
<b>Humidity</b>	<p><b>Operating:</b> 8 to 85% RH, non-condensing</p> <p><b>Non-operating:</b> 8 to 90% RH, non-condensing</p>
<b>Altitude</b>	<p><b>Operating:</b> 0 to 3,048m (10,000 ft.)</p> <p><b>Non-operating:</b> 0 to 9,144m (30,000 ft.)</p>
<b>Shock</b>	<p><b>Operating:</b> ½-sine: 40g, 2-3ms</p> <p><b>Non-operating:</b></p> <ul style="list-style-type: none"> <li>• ½-sine: 160 cm/s, 2-3ms (~100g)</li> <li>• square: 422 cm/s, 20g</li> </ul> <p><b>NOTE:</b> Values represent individual shock events and do not indicate repetitive shock events.</p>
<b>Vibration</b>	<p><b>Operating random:</b> 0.5g (rms), 5-300 Hz</p> <p><b>Non-operating random:</b> 2.0g (rms), 10-500 Hz</p> <p><b>NOTE:</b> Values do not indicate continuous vibration.</p>

## PCI card slot power specification

**Table 1-8** PCI and PCI Express slot power specifications

Slot#	Slot Type	Slot Power (Maximum)
1	PCI Express x16 (x8)	25W*
2	PCI Express x16 graphics	150W**
3	PCI 32 bit, 33 MHz	25W*
4	PCI Express x16 (x8)	25W*
5	PCI Express x16 graphics	150W**
6	PCI-X 100	25W*
7	PCI-X 100/133	25W*

\* In addition to these slot power specifications, the overall power consumption of the system (including I/O cards, processor, and memory) must not exceed the maximum ratings of the system power supply. See [Power supply specifications on page 8](#) for details.

\*\* Includes 75 W maximum from the system board connector, and 75 W maximum from the auxiliary graphics power connector.



 **NOTE:** If a graphics card requiring more than 75W is installed in Slot 2, HP recommends not using slot 3, which is the PCI slot below the graphics slot. If a graphics card requiring more than 75W is installed in slot 5, HP recommends not using slot 6, which is the PCI-X 100 slot below the graphics slot. In addition to these slot power specifications, the overall power consumption of the system (including I/O cards, processors, memory, and drives) must not exceed the maximum ratings of the system power supply. Also, there are broad restrictions on using dual 150W graphics cards.

For hardware specifications of other system components, such as graphics cards or optical drives, see the website of the specific manufacturer.

## Chipkill support

Chipkill is a form of advanced Error Checking and Correcting (ECC) computer memory technology. The HP xw9400 Workstation supports 128-bit Chipkill ECC memory functionality. Standard ECC functionality detects and corrects single bit data errors in memory systems. But Chipkill offers greater memory error protection by providing error correction for up to 4-bit errors within the same symbol (nibble boundary). Chipkill cannot correct any random four bits across 128 bits.

Chipkill on the xw9400 functions within these parameters:

- The workstation enables Chipkill functionality on paired ECC memory DIMMs only.
- The use of single memory DIMM—not supported on the xw9400 workstation—allows standard single bit ECC only.
- Chipkill can detect and correct up to four bit errors if the four bits are in the same symbol. That is, multiple bit errors in bits 0–3 or 4–7 of a byte can be detected and corrected. Multi-bit error that overlap or span symbol boundaries (bits 2–5 or 3–6, for example) cannot be corrected. For DIMMs that are based on x4 parts, this means that a single DRAM chip can fail and the system will continue to operate. For x8 and x16 parts, a complete DRAM chip cannot fail, but symbol errors will be corrected as described.

## ENERGY STAR Qualification

HP computers marked with the ENERGY STAR logo are compliant with the applicable U.S. Environmental Protection Agency (EPA) ENERGY STAR specifications for computers. The EPA ENERGY STAR logo does not imply endorsement by the EPA. As an ENERGY STAR Partner, Hewlett-Packard Company has determined the products marked with the ENERGY STAR logo are ENERGY STAR qualified per the applicable ENERGY STAR guidelines for energy efficiency. The following logo appears on all ENERGY STAR qualified computers.



The ENERGY STAR Computers Program was created by the EPA to promote energy efficiency and reduce air pollution through more energy-efficient equipment in homes, offices, and factories. One way products achieve this energy efficiency is by reducing power consumption when not being used through the Microsoft Windows Power Management feature.

The Power Management feature enables the workstation to enter a low-power (or “sleep”) mode after a period of inactivity. When used with an external monitor that is ENERGY STAR qualified, this feature also supports the similar power management features of the external monitor.

To take advantage of this energy savings:

- The Power Management feature has been preset to suspend the workstation to a sleep state after 30 minutes of inactivity.
- The Power Management feature has been preset to suspend the monitor to a sleep state after 15 minutes of inactivity.

Both the computer and monitor can be woken from sleep mode through user interaction with any of the computer input devices (mouse, keyboard, and so on). when configured with Wake On LAN (WOL) enabled, the workstation can also be woken by a network signal.

See the EPA ENERGY STAR Power Management Web site for more information about the energy and financial savings potential of the Power Management Feature: <http://www.energystar.gov/powermanagement>.

See the EPA ENERGY STAR Web site for more information about the ENERGY STAR program and its environmental benefits: <http://www.energystar.gov>.

---

△ **CAUTION:** Using the Energy Save Monitor feature with monitors that are not ENERGY STAR qualified can cause video distortion when an Energy Save timeout occurs.

---

 **NOTE:** ENERGY STAR is not supported on Linux workstations.

---

If it is necessary to restore the operating system, you must also reset the ENERGY STAR settings (if applicable) after the restore.

---

To verify the factory default power settings for your workstation, select **Start>Control Panel**, and then double-click **Power Options**.

## Multi-core processors

This HP Workstation supports selected AMD Opteron™ 2000 series multi-core processors that provide multiple true processors in a single socket. Multi-core processors are better at handling the load of multi-threaded applications (such as rendering images in Digital Content Creation) and highly multi-tasked environments (such as running several productivity applications while listening to music).

---

## 2 Setting up the operating system

This chapter provides setup and update information for the workstation operating system. It includes these topics:

---

### Topics

---

[Setting up the Microsoft operating system on page 14](#)

---

[Setting up Red Hat Enterprise Linux on page 15](#)

---

[Setting up Novell SLED on page 16](#)

---

[Updating the workstation on page 16](#)

---

This chapter also includes information on how to determine that you have the latest BIOS, drivers, and software updates installed on the workstation.

- 
- △ **CAUTION:** Do not add optional hardware or third-party devices to the HP workstation until the operating system is successfully installed. Adding hardware might cause errors and prevent the operating system from installing correctly.
-

## Setting up the Microsoft operating system

 **NOTE:** If you ordered a downgrade from Windows Vista to Windows XP Professional operating system, your system will be preinstalled with Windows XP Professional operating system. With this configuration, you will receive recovery media for Windows Vista operating system only. In case you need to restore or recover the Windows XP Professional operating system in the future, it is important that you create recovery media disks for Windows XP Professional operating system after first boot.

When you first apply power to the workstation, the operating system is installed. This process takes approximately 5 to 10 minutes. Carefully follow the instructions on the screen to complete the installation.

 **CAUTION:** After installation has started, do *not* turn off the workstation until the process is complete. Turning off the workstation during installation can damage the installation and operation of the software.

For complete operating system installation and configuration instructions, see the operating system documentation that was provided with the workstation. Additional information is available in the online help tool after you successfully install the operating system.

### Installing or upgrading device drivers

To install hardware devices after the operating system is installed, you must install the appropriate device drivers before you install the devices. Follow the installation instructions that came with the device. In addition, for optimum performance, your operating system must have the most recent updates, patches, and software fixes. For additional driver and software update information, refer to [Upgrading device drivers on page 18](#).

### Transferring files and settings to your Windows workstation

The Microsoft Windows operating system offers data migration tools that helps you choose and transfer files and data from a Windows computer to your Windows Vista or Windows XP Professional operating system workstation.

For instructions on how to use these tools, see the documents at <http://www.microsoft.com>.

## Setting up Red Hat Enterprise Linux

HP offers an HP Installer Kit for Linux (HPIKL) to supplement Red Hat box sets and help HP Linux customers customize their system image. The HPIKL contains the HP driver CD and device drivers to successfully setup up the Red Hat Enterprise Linux (RHEL) operating system, The HP Installer Kit for Linux CDs are currently available for download at [http://www.hp.com/support/workstation\\_swdrivers](http://www.hp.com/support/workstation_swdrivers).

### Installing with the HP driver CD

To install the HP driver CD, see “Installing with the HP Installer Kit for Linux” in the *HP Workstations for Linux* manual at [http://www.hp.com/support/workstation\\_manuals](http://www.hp.com/support/workstation_manuals).

## Installing and customizing Red Hat-enabled workstations

Linux-enabled workstations require the HP Installer Kit and the purchase of a Red Hat Enterprise Linux box set. The Installer kit includes the HP CDs necessary to complete the installation of all versions of the Red Hat Enterprise Linux box set that have been qualified to work on an HP workstation.

To use the drivers in the HP Installer kit for Linux other than RHEL, you must manually extract the drivers from the HP Driver CD and install them. HP does not test the installation of these drivers on other Linux distributions nor does HP support this operation.

### Verifying hardware compatibility

To see which Linux versions have been qualified to work on HP Workstations visit [http://www.hp.com/support/linux\\_hardware\\_matrix](http://www.hp.com/support/linux_hardware_matrix).

## Setting up Novell SLED

To set up the SUSE Linux Enterprise Desktop (SLED) on systems preloaded with the operating system:

1. Boot the workstation.
2. Start the Installation Settings and enter the password, network, graphics, time, keyboard settings, and Novell Customer Center Configuration for the workstation.



**NOTE:** During Installation Settings after the first time after booting the system the Novell subscription can be activated from the Novell Customer Center Configuration screen. Visit the full Novell Customer Center documentation at <http://www.novell.com/documentation/ncc/>.

## Updating the workstation

HP is constantly working on improving your total workstation experience. To ensure that the workstation leverages the latest enhancements, HP recommends that you install the latest BIOS, driver, and software updates on a regular basis.

### Updating the workstation after first boot

After successfully booting the workstation for the first time, you should follow these guidelines to ensure that the workstation is up-to-date:

- Ensure that you have the latest system BIOS loaded. See [Upgrading the BIOS on page 16](#) for instructions.
- Ensure that you have the latest drivers for your system. See [Upgrading device drivers on page 18](#) for instructions.
- Become familiar with your available HP resources.
- Consider a subscription to Driver Alerts at <http://www.hp.com/go/subscriberschoice>.

### Upgrading the BIOS

For optimum performance, determine the BIOS revision on the workstation, and upgrade it if necessary.

## Determining current BIOS

To determine the current BIOS of the workstation during system power up:

1. Wait for F10=setup to appear on the lower right corner of the screen.
2. Press **F10** to enter the F10 Setup utility.

The F10 Setup utility displays the workstation BIOS version under **File > System Information**.

3. Note the workstation BIOS version so that you can compare it with the BIOS versions that appear on the HP website.

## Upgrading BIOS

To find and download the latest available BIOS, which includes the latest enhancements:

1. Go to <http://www.hp.com/go/workstationsupport>.
2. Select **Download Drivers and Software** from the left menu column under Tasks.
3. Follow the instructions to locate the latest BIOS available for the workstation.
4. If the BIOS on the Web site is the same as the version on your system, no further action is required.
5. If the BIOS on the Web site is a version later than the one on your system, download the appropriate version for the workstation. Follow the instructions in the release notes to complete the installation.

## Upgrading device drivers

If you install a peripheral device (such as a printer, display adapter, or network adapter), confirm you have the latest device drivers loaded. If you purchased your device through HP, visit the HP Web site to download the latest drivers for your device. These drivers have been tested to ensure the best compatibility between your device and your HP workstation.

If you did not purchase your device from HP, HP recommends visiting the HP Web site first to see if your device and its drivers have been tested for HP workstation compatibility. If no driver is available, visit the device manufacturer's Web site to download the latest drivers.

To upgrade device drivers:

1. Go to <http://www.hp.com/go/workstationsupport>.
2. Select **Download Drivers and Software** from the left menu column under Tasks.
3. Follow the instructions to find the latest drivers available for the workstation.

If a needed driver is not found, see the Web site of the manufacturer of the peripheral device.



---

# 3 Restoring the operating system

This chapter describes how to restore the Windows or Linux operating system. It includes these topics:

---

## Topics

---

[Restore methods on page 19](#)

---

[Ordering backup software on page 20](#)

---

[Restoring Windows Vista on page 20](#)

---

[Restoring Windows XP Professional on page 21](#)

---

[Restoring Novell SLED on page 23](#)

---

[Installing with the HP driver CD on page 15](#)

---

## Restore methods

The Windows Business Vista operating system can be reinstalled using the HP RestorePlus! process. The Windows XP Professional operating system can be reinstalled using the RestorePlus! process or the HP Backup and Recovery Manager.

- RestorePlus!

The RestorePlus! process reinstalls the Windows operating system and device drivers (for devices included with the system) to a near-factory state. The process does not back up or recover data on the hard drive. Some application software might not be restored using this process and must be installed from the appropriate application CD.

- HP Backup and Recovery Manager (HPBR) Recovery Point

The HP Backup and Recovery Manager application can be used to capture and restore the contents of the system partition. It captures a snapshot of the system partition and stores it in a Recovery Point. Everything on the system partition at the time the recovery point was made is saved.

 **NOTE:** HP Backup and Restore is only supported on the HP xw6600 and xw8600 Workstations.

The Recovery Point is saved to the hard drive and can be burned to media for safekeeping.

△ **CAUTION:** These methods restore the operating system, but not data. Data must be backed up regularly to avoid loss.

---

## Ordering backup software

If you cannot create system recovery CDs or DVDs, you can order a recovery disk set from the HP support center. To obtain the support center telephone number for your region visit <http://www.hp.com/support/contactHP>.

## Restoring Windows Vista

This section describes how to restore Windows Vista.

### Ordering the RestorePlus! media

If you ordered restore media with your workstation, the media is included with your workstation components.

If you did not order restore media, call HP Support and request a RestorePlus! media kit. For worldwide technical support phone numbers, visit <http://www.hp.com/support>.

### Restoring the operating system

---

 **NOTE:** Windows Vista provides a backup and restore application as well. To learn more about this application, visit the Microsoft Web site.

 **CAUTION:** Before you restore the operating system, back up your data.

When you run RestorePlus! from media, the process deletes all information on the primary hard drive, including all partitions.

---

To restore Windows Vista:

1. Boot from the RestorePlus! DVD to start the RestorePlus! process. You must start from the RestorePlus! DVD to install device drivers and settings.
2. Follow the prompts to restore your operating system.

Some application software might not be restored using this process. If software is not restored, install it from the appropriate application DVD.

# Restoring Windows XP Professional

This section describes how to restore the Windows XP Professional operating system.

 **NOTE:** The workstation must have a CD or DVD writer installed to create the media set.

---

## Creating RestorePlus! media

The RestorePlus! kit can be created using the files contained on the hard drive. To create the restore media:

1. Boot the workstation.
2. During boot up, an HP Backup and Recovery Manager screen is displayed prompting you to create Recovery CDs or DVDs. Select **Now**.
3. An Initial Recovery Point (IRP) of the system is captured. This is a snapshot of the system hard drive. The capture can take more than 10 minutes.
4. After the IRP is created, you can create a set of backup CDs or DVDs.

To create a RestorePlus! media set including the Windows XP operating system CD, select **RestorePlus! > Microsoft Windows XP operating system > Supplemental media**.

 **NOTE:** Depending on the options, there might be additional DVDs you can create.

---

5. Follow the prompts to create RestorePlus!, operating system, and HPBR media.

If you are unable to create CD/DVDs on your workstation, call HP Support and request a RestorePlus! media kit. For worldwide technical support phone numbers, visit <http://www.hp.com/support>.

## Creating HP Backup and Recovery (HPBR) media

---

 **NOTE:** HPBR functionality is used with Windows XP only. For details, refer to the *SoftThinks* guide on the *Documentation and Diagnostics* CD included with the workstation.

---

The Initial Recovery Point can be burned to optical media and used to recover a system. This section describes making the media.

---

 **NOTE:** The workstation must have a CD or DVD writer to create the media set.

---

To create HPBR recovery media:

1. The Initial Recovery Point was captured when the RestorePlus! media set was created previously.  
If the IRP was not created, start the HP Backup and Recovery Manager and create recovery points using the Expert mode. Follow the HPBR online documentation for instructions.
2. Burn the IRP to media from HPBR.  
Select **HPBR Start > All Programs > HP Backup & Recovery > HP Backup and Recovery Manager**.
3. Select **Next** at the first screen.  
Select **Create recovery CDs or DVDs to recover the system**, and then select **Next**.
4. Choose **Next** to display a list of available CD image and the recovery points.
5. Check the box next to Initial Recovery Point, and then select **Next**.
6. Follow the instructions to create the media.

## Restoring the operating system

△ **CAUTION:** Before you restore the operating system, back up your data.

When you run RestorePlus! from media, the process deletes all information on the primary hard drive, including all partitions. If you run RestorePlus! from the recovery partition, only the root (C:) partition is affected.

### Using RestorePlus!

To restore with RestorePlus!:

1. Boot the workstation from the RestorePlus! DVD. You must start from the RestorePlus! DVD for device drivers and settings to be installed.
2. Follow the prompts to restore the operating system.

Some application software might not be restored using this process. If software is not restored, install it from the appropriate application DVD.

### Using HPBR

To restore with the HPBR Initial Recovery Point media:

1. Boot the workstation from the Initial Recovery Point media.
2. Follow the prompts to restore the system to the state when the IRP was created.

### Using the recovery partition

A system that shipped with Windows XP includes a recovery partition. You can boot the system from that recovery partition.

From the recovery partition you can perform a system restore using the HPBR Initial Recovery Point, if it was created. If it was not, you can use a RestorePlus! install.

To restore using the recovery partition:

1. Boot the workstation.
2. When prompted on the boot screen to enter the Recovery Manager, press **F11**.

💡 **TIP:** The opportunity to press F11 during the boot process is small. It comes about the time the F10 prompt appears.

📝 **NOTE:** To ensure that the recovery processes reinstall on the correct hard drive, do not disconnect the target drive during the recovery process.

3. Follow the prompts to restore the system to factory-like condition.

## Restoring Novell SLED

The SLED restore media is required to restore the Linux operating system.

### Creating restore media

THE SUSE Linux Enterprise Desktop preload includes a SUSE ISO icon on the desktop. You can click this icon to go to the `/iso` directory. The `/iso` directory contains all iso images used to preload your workstation. To recover or restore the original image, follow the instructions in the readme file in the `/iso` directory to copy the ISO image file onto CDs.

---

 **NOTE:** Make copies of the ISO recovery images on CD as backup files in case your workstation experiences a hard drive failure.

---

---

## 4 System management

This section describes the various tools and utilities that allow for the system management of the workstation.

- [Computer Setup \(F10\) Utility on page 25](#)
- [Desktop management on page 36](#)

### Computer Setup (F10) Utility

The Computer Setup Utility enables you to:

- Change current settings from the factory default settings.
- Modify or restore factory default settings.
- Determine if all of the devices installed on the workstation are recognized by the system and functioning properly.
- Determine information about the operating environment of the workstation.
- Solve system configuration errors detected but not automatically fixed during the Power-On Self-Test (POST).
- Establish and manage security features and password prompting during system reset and during power-on.
- Establish and manage energy-saving time-outs (not supported for Linux platforms).
- Set the system date and time.
- Set, view, and change the system configuration, including settings for processor, graphics, memory, audio, storage, communications, and input devices.
- Modify the boot order of installed mass storage devices such as hard drives, diskette drives, optical drives, and network drives.
- Enable or disable Network Server Mode, which enables the workstation to boot the operating system when the power-on password is enabled with or without a keyboard or mouse attached. When attached to the system, the keyboard and mouse remain locked until the power-on password is entered.
- Enable/disable POST Messages to change the display status of POST messages. POST messages disabled suppresses most POST messages, such as memory count, product name, and other non-error text messages. If a POST error occurs, the error is displayed regardless of the mode selected. To temporarily switch to POST messages enabled, press any key (except F1 through F12) during POST.
- Establish an Ownership Tag, the text of which is displayed each time the system is turned on or restarted.
- Enter the Asset Tag or property identification number assigned by your company to this workstation.

- Secure the integrated I/O functionality, including the serial and USB ports, audio, embedded NIC, SAS, or IEEE 1394 so that the I/O functionality cannot be used until they are unsecured.
- Enable or disable removable media boot ability.
- Enable or disable removable media write ability (when supported by hardware). Used commonly for legacy diskettes.
- Replicate your system setup by saving system configuration information onto diskette or USB, or restoring it onto one or more workstations.

## BIOS ROM

The BIOS of the computer is a collection of programs stored as firmware in ROM. The BIOS ROM includes such functions as POST, PCI device initialization, Plug 'n' Play support, power management activities, and the Computer Setup Utility. BIOS supports the following systems and specifications:

- Dual AMD Opteron 2xxx series processors
- Up to DDR2-667 memory
- HyperTransport setup and initialization
- Chipset (includes NVIDIA nForce Professional 3600 and 3050 with NEC ?PD720404 PCIe to PCI-X bridge)
- ACPI 1.0b with ACPI 2.0 extensions for 64-bit support, according to Microsoft Logo Requirements. S1, S3, S4, and S5 with Remote Power On by way of LAN wake packet.
- SMBIOS Spec 2.5 implementation and field definitions that accurately represent hardware configurations and OEM ID
- BBS 1.01
- DOS and Windows based BIOS flash tools
- Microsoft SDG 3.0 compliant as applicable
- PMM 1.01 as applicable
- MPS 1.4 as applicable
- PXE 2.1
- USB 1.1/USB 2.0
- PCI 2.2 or later
- "El Torito" Bootable CD 1.0

The BIOS ROM is a 1-MB FLASH unit. The runtime portion of the BIOS resides in a 96-KB block from E8000h to FFFFFh (approximately). ACPI code and data take about 128 KB below TOLM (top of low memory, the last RAM address below 4 GB).



## Using Computer Setup (F10) Utility

You can call up the Computer Setup Utility during workstation restart or power on. To access the Computer Setup Utility menu:

1. Power on or restart the workstation.
2. Press the **F10** key as soon as your display is active and the message **Setup** appears in the lower right corner of the screen.

---

 **NOTE:** If you miss the opportunity to press F10, restart the workstation and press **F10** again. Or, you can press **Ctrl+Alt+Delete** prior to boot .

---

3. At first boot, select your language from the list, and press the **Enter** key. In the Computer Setup Utility menu, five headings are displayed: **File**, **Storage**, **Security**, **Advanced**, and **I/O**.
4. Use the left and right arrow keys to select the appropriate heading. Use the up and down arrow keys to select the option you want, and press **Enter**.
5. To apply and save changes, select **File>Save Changes and Exit**.
  - If you have made changes that you do not want applied, select **File>Ignore Changes and Exit**.
  - To reset to factory settings, select **File>Default Setup>Restore Factory Settings as Default**. Press **F10** to accept the changes. Click **File>Apply Defaults and Exit**. This option restores the original factory system defaults.

---

△ **CAUTION:** Do **not** turn the workstation power off while the ROM is saving your Computer Setup Utility changes because the CMOS could become corrupted. After you exit the F10 Setup screen, it is safe to remove all power from the workstation.

---

## Computer Setup (F10) Utility menu

 **NOTE:** The following content is subject to change with new BIOS releases, so your menu may be different than shown in Table 1–1.

**Table 4-1 Computer Setup Utility menu descriptions**

Heading	Option	Description	
File	System Information	Lists product name, SKU number, processor type/speed/stepping, cache size (L1/L2), memory type and size, integrated Media Access Control (MAC) IDs for Network Interface, system BIOS type, chassis serial number, asset tracking number, and Boot Block Date.	
	About	Displays copyright information.	
	System Temperatures	Displays temperature graph.	
	Set Time and Date	Enables you to set system time and date.	
	Flash System ROM	Enables you to select a device from which to flash system ROM.	
	Replicated Setup	Save to Removable Media	Saves the current F10 Setup configuration to a text file called <code>cpqsetup.txt</code> .
		Restore from Removable Media	Restores previous F10 Setup configuration from a text file called <code>cpqsetup.txt</code> .
	Default Setup	Save Current Settings as Default	Stores the current F10 Setup configuration as the default.
		Restore Factory Settings as Default	Restores the original factory settings to the F10 Setup configuration information as the default.
	Apply Defaults and Exit	Saves the selected default settings (previously-saved user or factory settings) and exits the Computer Setup Utility.	
Ignore Changes and Exit	Exits the Computer Setup Utility without applying or saving any changes.		
Save Changes and Exit	Saves changes to system configuration and exits the Computer Setup Utility.		
Storage	Device Configuration	Lists all installed non-SAS and non-SATA storage devices.	
		When a device is selected, detailed information and options are displayed.	

**Table 4-1 Computer Setup Utility menu descriptions (continued)**

Heading	Option	Description
		<p>Hard Disk</p> <p>Identifies the hard disk drives on the system by model, firmware, serial number, connector color, emulation type, multisector transfers, and translation mode.</p> <p>By default, SATA drives are not listed here.</p> <p>Default values can be set here for IDE and SATA drives, but not for SAS drives.</p>
		<p>CD-ROM</p> <p>Identifies the optical drives on the system.</p>
		<p>Diskette (for legacy diskette drives only)</p> <p>Identifies the highest capacity media type accepted by the diskette drive. Options are 3.5" 1.44 MB, 5.25" 1.2 MB, and Not Installed.</p>
		<p>Default Values</p> <p>Enables you to set the default values for IDE and SATA devices such as the following:</p> <ul style="list-style-type: none"> <li>• Multisector Transfers (IDE devices only)—Specifies how many sectors are transferred per multi-sector Programmed Input/Output (PIO) operation. Options (subject to device capabilities) are Disabled, 8, and 16.</li> <li>• Transfer Mode (IDE devices only)—Specifies the active data transfer mode. Options (subject to device capabilities) are PIO 0, Max PIO, Enhanced DMA, Ultra DMA 0, and Max UDMA.</li> <li>• Translation Mode (IDE/SATA disks only)—Enables you to select the translation mode to be used for the device, which enables the BIOS to access disks partitioned and formatted on other systems and may be necessary for users of older versions of UNIX (for example, SCO UNIX version 3.2). Options are Bit-Shift, LBA Assisted, Off, User, and Automatic.</li> </ul> <p><b>NOTE:</b> The Automatic option allows BIOS to automatically determine the translation mode used to configure a previously-formatted IDE, SATA, or USB mass storage device. Hence, you do not have to know how the mass storage device was previously formatted.</p> <p>Ordinarily, the translation mode selected automatically by the BIOS should not be changed. If the selected translation mode is not compatible with the translation mode that was active when the disk was partitioned and formatted, the data on the disk will be inaccessible.</p>
	Storage Options	<p>Removable Media Boot</p> <p>Enables/disables ability to boot the system from removable media.</p>
		<p>Legacy Diskette Write</p> <p>Enables/disables ability to write data to legacy media.</p>
		<p>BIOS DMA Data Transfers</p> <p>Enables/disables DMA transfers for IDE and SATA devices when possible during POST to increase transfer speed.</p>
		<p>SATA Controller #0</p> <p>Enables/disables SATA controller 0.</p>
		<p>SATA Controller #1</p> <p>Enables/disables SATA controller 1.</p>

**Table 4-1 Computer Setup Utility menu descriptions (continued)**

Heading	Option	Description
		SATA Controller #2 Enables/disables SATA controller 2.
		IDE Controller Enables/disables IDE controller.
	Boot Order	<p>Enables you to configure the boot, diskette drive, and hard drive orders by physically reordering the menu entries. Each device on the list can be individually excluded from or included for consideration as a bootable operating system source. Boot Order presents these selections:</p> <ul style="list-style-type: none"><li>• Optical drive</li><li>• Diskette drive</li><li>• USB device</li><li>• Hard drive</li><li>• Network controllers (2)</li></ul> <p>Boot devices can be disabled from participating in the boot order process. Boot order changes are stored when the F10 Setup changes are confirmed by selecting <b>File&gt;Save Changes and Exit</b>.</p> <p><b>NOTE:</b> MS-DOS drive lettering assignments might not apply after a non-MS-DOS operating system has started.</p> <p><b>Shortcut to Temporarily Override Boot Order</b></p> <p>To boot <b>one time</b> from a device other than the default device specified in Boot Order, restart the workstation and press the <b>F9</b> key when the <b>F9=Boot Menu</b> message appears on the screen. After POST is completed, a list of bootable devices is displayed. Use the arrow keys to select the preferred bootable device and press <b>Enter</b>. The workstation then boots from the selected device for this one time.</p>
Security	Setup Password	<p>Enables you to set and enable setup (administrator) password.</p> <p><b>NOTE:</b> If the setup password is set, you must enter Computer Setup Utility to change it, flash the ROM, and make changes to certain plug-and-play settings under Windows.</p>
	Power-On Password	<p>Enables you to set and enable the power-on password.</p> <p><b>NOTE:</b> If a power on-password is set, or the workstation cover removal sensor is activated, entries for these items will appear in this list.</p>

**Table 4-1 Computer Setup Utility menu descriptions (continued)**

Heading	Option	Description
	Device Security	<p>Makes the following devices available or hidden to the system:</p> <ul style="list-style-type: none"> <li>• Serial Port</li> <li>• All USB Ports</li> <li>• External USB ports</li> <li>• Front USB Ports</li> <li>• System Audio</li> <li>• IEEE 1394 Controller</li> <li>• Network Controller 1</li> <li>• Network Controller 2</li> <li>• Onboard SAS Controller</li> <li>• Embedded Security Device</li> </ul> <p>For each device, Device Available is the default setting and allows the operating system access to the device. Device hidden makes the device unavailable; it is disabled by the BIOS and cannot be enabled by the operating system.</p> <p>When enabled, Embedded Security Device offers these options:</p> <ul style="list-style-type: none"> <li>• Enable/disable—Turns the TPM on/off.</li> <li>• Power-On Authentication Support—Enables/disables an authentication feature that requires you to enter a TPM user key password to boot the system. This feature uses the TPM to generate and store the authentication password.</li> <li>• Reset Authentication Credential—Resets the authentication functionality and clears all authentication credentials.</li> </ul> <p><b>NOTE:</b> A setup password must be set to enable the Embedded Security Device and to access any security features associated with the Embedded Security Device.</p>
	Network Service Boot	<p>Enables/disables a Network Service Boot which boots using the NIC PXE option ROM. In this case, the actual boot image resides on a remote server. When enabled, you can set the boot order of the NIC PXE option ROM and you can force a network boot by pressing F12 during POST.</p>
	System IDs	<p><b>Asset Tag</b></p> <p>A 16–byte string identifying the system.</p> <hr/> <p><b>Ownership Tag</b></p> <p>An 80–byte string identifying ownership of the system. This tag is displayed on the screen during POST.</p> <hr/> <p><b>UUID (Universal Unique Identifier)</b></p> <p>Can only be updated if the current chassis serial number is invalid. (These ID numbers are normally set in the factory and are used to uniquely identify the system.)</p> <hr/> <p><b>Keyboard</b></p> <p>Enables you to set the keyboard locale for System ID entry.</p>

**Table 4-1 Computer Setup Utility menu descriptions (continued)**

Heading	Option	Description
	OS Security	<p>Data Execution Prevention</p> <p>Enables/disables Data Execution Prevention mode in the processors. This mode prohibits code from running in pages that were set up as data pages, and prevents attacks such as buffer overflows. Operating system support is required for this feature.</p>
		<p>AMD Virtualization Technology</p> <p>Enables AMD Virtualization Technology to increase workstation performance.</p>
		<p>OS Management of Embedded Security Device</p> <p>Enables/disables the ability of the operating system to control the TPM device. This includes turning it on/off, initializing it, and resetting it.</p>
		<p>Reset of Embedded Security Device through OS</p> <p>Enables/disables the ability of the operating system to reset the TPM.</p>
Advanced**	Power-On Options	<p>Allows you to set:</p> <ul style="list-style-type: none"> <li>• POST Mode (QuickBoot, FullBoot, or FullBoot every 1–30 days).</li> <li>• POST Messages (Enable/Disable).</li> <li>• F9 Prompt (Enable/Disable). Enabling this feature will display the text F9=Boot Menu during POST. Disabling this feature prevents the text from being displayed. However, pressing the <b>F9</b> key will still access the boot menu.</li> <li>• <b>F10</b> Prompt (Enable/Disable). Enabling this feature displays the text F10=Setup during POST. Disabling this feature prevents the text from being displayed but pressing <b>F10</b> still accesses the Setup screen.</li> <li>• <b>F11</b> Prompt (Enable/Disable). Makes the Factory Recovery option visible during POST.</li> <li>• <b>F12</b> Prompt (Enable/Disable). Enabling this feature displays the text <b>F12=Network Service Boot</b> during POST. Disabling this feature prevents the text from being displayed but pressing <b>F12</b> still forces the system to attempt booting from the network.</li> <li>• Factory Recovery Boot Support (Enable/Disable). Recovery partition (HDD) option available for Vista. Vista leaves the factory with this support in place.</li> <li>• Option ROM* prompt (Enable/Disable). Enabling this feature causes the system to display a message before loading options ROMs.</li> <li>• Remote Wakeup Boot Source</li> <li>• After Power Loss (on/off)</li> <li>• POST Delay (in seconds) (Enable/Disable). Enabling this feature adds a user-specified delay to the POST process. This delay is sometimes needed for hard disks on some PCI cards that spin up slowly—so slowly that they are not ready to boot by the time POST is finished. The POST delay also gives you more time to select <b>F10</b> to enter Computer Setup (F10).</li> <li>• I/O APIC Mode (Enable/Disable)</li> <li>• Limit (PUID Maximum Value to 3) (Enable/Disable)</li> <li>• Setup Browse Mode (Enable/Disable)</li> <li>• ACPI/USB Buffers @ Top of Memory (Enable/Disable)</li> </ul>

**Table 4-1 Computer Setup Utility menu descriptions (continued)**

Heading	Option	Description
		POST Messages (Enable/Disable). When enabled, POST displays non-error messages to the screen.
		F9 Prompt (Displayed/Hidden) Displays <b>F9=Boot Menu</b> during POST. Hiding this feature prevents the text from being displayed, but pressing <b>F9</b> still calls up the boot menu.
		F10 prompt (Displayed/Hidden) Displays <b>F10=Setup</b> during POST. Hiding this feature prevents the text from being displayed but pressing <b>F10</b> still accesses the Setup screen.
		F12 prompt (Displayed/Hidden) Displays <b>F12=Network Service Boot</b> during POST. Hiding this feature prevents the text from being displayed, but pressing <b>F12</b> still forces the system to attempt booting from the network.
		Option ROM* Prompt (Enable/Disable) When enabled, causes the system to display a message before loading options ROMs.
		Remote Wakeup Boot Source Enables you to specify which boot device to use after a remote wake event.
		After Power Loss (Off/On/Previous State) In the event of an AC power loss, determines system behavior when power is restored. Options are <b>Off</b> (stay off), <b>On</b> (turn on immediately), and <b>Previous State</b> (if the computer was on when power was lost, power on immediately; if it was off, stay off).
		POST Delay (in seconds) (None, 5, 10, 15, 20) Specifies a delay during POST. This setting may be necessary for certain add-in peripherals that respond slowly or violate specifications. For instance, disk drives should spin up within 15 seconds, but some older drives might take longer.
		Setup Browse Mode (Enable/Disable) Enables viewing Setup Options without entering Setup password. <b>Enable</b> allows you to view Setup in read-only mode if you do not enter the Setup password. <b>Disable</b> blocks Setup entirely if you do not enter the Setup password. This option is only valid if a Setup password is set.
	Thermal	Fan Idle Mode This setting changes the minimum fan speed. The fans are still automatically controlled. The internal fans of the system are controlled automatically to guarantee proper operation of any configuration shipped from the factory. However, some customers with cards and configurations with special thermal/cooling needs may need to increase the minimum spinning speed of the fans in the system. They can do so by using this menu and selecting a higher minimal fan speed.
	BIOS Power-On	Enables you to disable or specify a day and time for BIOS power-on.
	OS Power Management	ACPI S3 Support (Enable/Disable) Enables/disables ACPI S3 suspend-to-RAM (Standby) from OS.

**Table 4-1 Computer Setup Utility menu descriptions (continued)**

Heading	Option	Description
		ACPI S3 Hard Disk Reset (Enable/Disable) When awakening from the ACPI S3 state, reset IDE hard drive before returning to the OS.
		ACPI S3 PS2 Mouse Wake Up (Enable/Disable) Allow the mouse to awaken the system from the ACPI S3 state.
		USB Wake on Device Insertion (Enable/Disable) Awaken the system from ACPI S3 state on USB device insertion.
	Execute Memory Test	System reboots and executes the memory test.
	Chipset/ Memory	<ul style="list-style-type: none"><li>• Coherent HT: 1000 MHz, 2200 MHz default (Available on selected workstations).</li><li>• ECC Support (Enable/Disable) Enables/disables memory Error Correcting Code (ECC).</li></ul>
		Memory Scrubbing (Enable/Disable) Enables/disables memory ECC scrubbing. If ECC Support is enabled, the scrubbing feature walks through memory in the background to avoid accumulation of ECC errors in memory. Upon detection of an ECC error, either during the scrubbing walk-through or during normal processor-to-memory operation, the scrubbing mechanism corrects the data and writes it back into the corresponding memory DIMM module.
		Memory Node Interleave (Enable/Disable) This option is valid for dual-processor systems only. If enabled, BIOS interleaves the memory on CPU0 and CPU1 together. This option requires the total memory installed on CPU0 (slots 1a/1b/3a/3b) and on CPU1 (slots 2a/2b/4a/4b) to be the same. If disabled, BIOS maps the memory connected to CPU0, then the memory connected to CPU1. The system is then effectively in NUMA mode.
		PCI SERR# Generation (Enable/Disable) Disables PCI SERR# generation for ill-behaved PCI add-in cards that can generate spurious SERRs.
		NET Watchdog Timer (Enable/Disable) Enables/disables the watchdog timer.
		ACPI Bus Segmentation (Enable/Disable) Enables/disables PCI bus segmentation. Disabling this option may prevent installation issues with some Linux implementations.
		HPET (Enable/Disable) Enables/disables the High Precision Event Timer. This feature must be enabled to use low power settings (PowerNow!). Some Linux implementations may require disabling this feature.



**Table 4-1 Computer Setup Utility menu descriptions (continued)**

Heading	Option	Description
I/O**	APIC Interrupts	<p>APIC</p> <p>Allow manual configuration of system IRQs.</p> <p>For more details on using this feature and on maximizing interrupt performance, refer to the <i>Optimizing APIC Interrupt Assignments on the xw9400</i> white paper available at <a href="http://tclperf.fc.hp.com/performance_briefs/index.htm">http://tclperf.fc.hp.com/performance_briefs/index.htm</a>.</p>
	Onboard Devices	Disable or set IRQ, DMA, and I/O Range values for legacy devices.
	PCI Devices	Disable or select IRQ values for PCI devices.
	Device Options	<p>NIC PXE Option ROM Download (Enable/Disable)</p> <p><b>Disable</b> means you cannot boot from this device, but more option ROM space is available for other devices.</p>
		<p>Onboard SAS Option ROM Download (Enable/Disable)</p> <p><b>Disable</b> means you cannot boot from SAS drives, but more option ROM space is available for other devices.</p>
		<p>SATA Option ROM Download (Enable/Disable)</p> <p>Enables or disables downloading embedded SATA option ROM. <b>Disable</b> means you cannot boot from SATA devices, but more option ROM space is available for other devices.</p>
		<p>SATA RAID (Enable/Disable)</p> <p>Enables or disables SATA drives for a RAID. If disabled, a single line is displayed. If enabled, the menu expands to allow enabling/disabling each SATA port.</p>
		<p>Num Lock State at Power-On (Off/On)</p> <p>Sets the keyboard <b>Num Lock</b> state after POST. The Operating System can change this state, also.</p>
		<p>S5 Wake on LAN (Enable/Disable)</p> <p>Allows the network to wake the system from shutdown (ACPI S5). When set to <b>Disable</b>, system power consumption is reduced to match Federal Energy Management Program (FEMP) guidelines.</p>
		<p>Unique Sleep State Blink Rates (Enable/Disable)</p> <p>Assigns different LED blink patterns for S1 and S3. (The system LED is off for S4 and S5.)</p>
		<p>Monitor Tracking (Enable/Disable)</p> <p>Enabling this option allows the ROM to save the monitor asset tracking information such as the serial number and model.</p>

**Table 4-1 Computer Setup Utility menu descriptions (continued)**

Heading	Option	Description
	Slot Options	Modifies options for: <ul style="list-style-type: none"><li>• Slot 1—PCI Express x8</li><li>• Slot 2—PCI Express x16 graphics</li><li>• Slot 3—PCI 32 bit, 33 MHz</li><li>• Slot 4—PCI Express x16 (x8)</li><li>• Slot 5—PCI Express x16 graphics</li><li>• Slot 6—PCI-X 100</li><li>• Slot 7—PCI-X 100/133</li></ul> For PCI Express slots, the available option is <b>Option ROM Download</b> . For PCI and PCI-X slots, the available options are <b>Option ROM Download</b> and <b>Latency Timer</b> .
* Available on select models.		
** These options should be used by advanced users only.		

## Desktop management

HP Client Management Solutions (available for download from <http://www.hp.com/go/easydeploy>) provides standards-based solutions for managing and controlling workstations in a networked environment. This section summarizes the capabilities and features of desktop management key components:

- [Initial configuration and deployment on page 36](#)
- [Remote system installation on page 37](#)
- [Managing and updating software on page 37](#)
- [ROM flash on page 39](#)
- [Asset tracking and security on page 43](#)
- [Fault notification and recovery on page 49](#)

 **NOTE:** Support for specific features described in this guide might vary by model or software version.

## Initial configuration and deployment

The workstation comes with a preinstalled system software image. After a brief software unbundling process, the workstation is ready to use.

You might prefer to replace the preinstalled software image with a customized set of system and application software. There are several methods for deploying a customized software image, including:

- Installing additional software applications after unbundling the preinstalled software image.
- Using software deployment tools, such as Altiris® Deployment Solutions™, to replace the preinstalled software with a customized software image.
- Using a disk cloning process to copy the contents from one hard drive to another.

The best deployment method depends on your information technology environment and processes. The PC Deployment section of the HP Lifecycle Solutions website (<http://whp-sp-orig.extweb.hp.com/country/us/en/solutions.html>) provides information to help you select the best deployment method.

The Restore Plus! CD, ROM-based setup, and ACPI hardware provide further assistance with recovery of system software, configuration management and troubleshooting, and power management.

## Remote system installation

Remote System Installation enables you to start and set up your system using the software and configuration information located on a network server. This feature is usually used as a system setup and configuration tool, and can be used for the following tasks:

- Deploying a software image on one or more new PCs
- Formatting a hard drive
- Installing application software or drivers
- Updating the operating system, application software, or drivers

To initiate Remote System Installation, press **F12** when **F12=Network Service Boot** appears in the lower-right corner of the HP logo screen. Follow the onscreen instructions to continue the process. The default boot order is a BIOS configuration setting that can be changed to always attempt to PXE boot.

HP and Altiris have partnered to provide tools designed to make the task of corporate PC deployment and management easier and less time-consuming, ultimately lowering the total cost of ownership and making HP PCs the most manageable client PCs in the enterprise environment.

## Managing and updating software

HP provides several tools for managing and updating software on desktops and workstations—HP Client Manager Software, Altiris Client Management Solutions, System Software Manager, Proactive Change Notification, and Subscriber's Choice.

### HP Client Manager software

HP Client Manager Software (HP CMS) assists you in managing the hardware aspects of your client workstations with features that include:

- Detailed views of hardware inventory for asset management
- PC health check monitoring and diagnostics
- Proactive notification of changes in the hardware environment
- Web-accessible reporting of business-critical details such as machines with thermal warnings, memory alerts, and more
- Remote updating of system software such as device drivers and ROM BIOS
- Remote changing of boot order
- Configuring the system BIOS settings

For more information on the HP Client Manager, see <http://www.hp.com/go/ssm>.

## Altiris Client Management solutions

HP and Altiris have partnered to provide comprehensive, tightly integrated systems management solutions to reduce the cost of owning HP client PCs. HP Client Manager Software is the foundation for additional Altiris Client Management Solutions that address:

- Inventory and asset management
  - Software license compliance
  - PC tracking and reporting
  - Lease contract and fixed asset tracking
- Deployment and migration
  - System deployment
  - Personality migrations
- Help desk and problem resolution
  - Managing help desk tickets
  - Remote troubleshooting
  - Remote problem resolution
  - Client disaster recovery
- Software and operations management
  - Ongoing desktop management
  - HP system software deployment
  - Application self-healing

See <http://www.hp.com/go/ssm> for more information about:

- How HP Client Manager Software works
- Which solutions are compatible with your operating system
- How to download a fully-functional, 30-day evaluation version of the Altiris solutions

## System Software Manager

System Software Manager (SSM) is a utility that enables you to update system-level software on multiple systems simultaneously. When executed on a PC client system, SSM detects both hardware and software versions and then updates the appropriate software from a central repository, also known as a file store. Driver versions that are supported by SSM are denoted with a special icon on the software, the driver download website, and the Support Software CD. To download the utility or to obtain more information on SSM, see <http://www.hp.com/go/ssm>.

## Proactive Change Notification

The Proactive Change Notification program uses the Subscriber's Choice website to proactively and automatically send you:

- Proactive Change Notification (PCN) emails informing you of hardware and software changes to most commercial workstations and servers, up to 60 days in advance.
- Emails containing Customer Bulletins, customer advisories, customer notes, security bulletins, and driver alerts for most commercial workstations and servers.

You create your own profile to ensure that you only receive the information relevant to a specific IT environment. To learn more about the Proactive Change Notification program and create a custom profile, see <http://www.hp.com/go/pcn>.

## Subscriber's Choice

Subscriber's Choice is a client-based service from HP. Based on your profile, HP supplies you with personalized product tips, feature articles, and driver and support alerts and notifications. Subscriber's Choice Driver and Support Alerts/Notifications deliver emails notifying you that the information you subscribed to in your profile is available for review and retrieval. To learn more about Subscriber's Choice and create a custom profile, see <http://www.hp.com/go/pcn>.

## ROM flash

The workstation comes with a programmable flash ROM. By establishing a setup password in the Computer Setup Utility, you can protect the ROM from being unintentionally updated or overwritten, which is important to ensure the operating integrity of the workstation. Should you need or want to upgrade the ROM, you can:

- Order an upgraded ROMPaq diskette from HP.
- Download the latest ROMPaq images from HP driver and support page, <http://www.hp.com/support/files>.

 **NOTE:** For maximum ROM protection, be sure to establish a setup password. The setup password prevents unauthorized ROM upgrades. System Software Manager enables you to set the setup password on one or more PCs simultaneously. For more information, see <http://www.hp.com/go/ssm>.

## Remote ROM flash

Remote ROM Flash enables you to safely upgrade the ROM on remote HP workstations directly from the centralized network management console. Performing this task remotely on multiple workstations and personal computers results in a consistent deployment of and greater control over HP ROM images over the network. It also results in greater productivity and lower total cost of ownership.

The workstation must be powered on to use Remote ROM Flash.

For more information on Remote ROM Flash, see the HP Client Manager Software or System Software Manager at <http://www.hp.com/go/ssm>.

## HPQFlash

The HPQFlash utility is used to locally update or restore the system ROM on individual workstations through a Windows operating system.

For more information on HPQFlash, see <http://www.hp.com/support/files> and enter the name of your workstation when prompted.

## FailSafe Boot Block ROM

The FailSafe Boot Block ROM allows for system recovery in the unlikely event of a ROM flash failure, for example, if a power failure occurs during a ROM upgrade. The Boot Block is a protected section of the ROM that checks for a valid system ROM flash when the system is powered on.

 **NOTE:** System recovery can use a removable medium such as a diskette, CD, or USB.

- If the system ROM is valid, the system starts normally.
- If the system ROM fails the validation check, the FailSafe Boot Block ROM provides enough support to start the system from a ROMPaq removable medium which will program the system ROM with a valid image.

 **NOTE:** Workstation models that support recovery from a ROMPaq CD provide ISO ROMPaq images in the downloadable ROM SoftPaq.

When the Boot Block detects an invalid system ROM, the System Power LED blinks red eight times, once every second, followed by a two-second pause. Also, you will hear eight beeps that correspond to the blinks. A Boot Block recovery mode message is displayed on the screen (some models).

To recover the system after it enters Boot Block recovery mode:

1. If a removable medium is loaded in the workstation, remove it and power down the workstation.
2. Insert the appropriate ROMPaq removable medium in the workstation.
3. Power on the workstation.

If no ROMPaq removable medium is found, you are prompted to insert one and restart the workstation.

If a setup password has been established, the Caps Lock light illuminates and you are prompted to enter the password.

4. Enter the setup password.

If the system successfully starts from the removable medium and successfully reprograms the ROM, the three keyboard lights illuminate.

5. Remove the removable medium and restart the system.

The following table lists the various keyboard light combinations used by the Boot Block ROM (when a PS2 keyboard is attached to the workstation) and explains the meaning and action associated with each combination.

**Table 4-2 PS2 keyboard light combinations used by Boot Block ROM**

Light*	State	Description
<b>FailSafe Boot Block Mode</b>	<b>Keyboard LED Activity</b>	<b>State/Message</b>
Num Lock	On	ROMPaq diskette or ROMPaq CD not present, is bad, or drive not ready
Caps Lock	On	Enter password
Num, Caps, Scroll Lock	Blink On in sequence, one at a time—N,C, SL	Keyboard locked in network mode

**Table 4-2 PS2 keyboard light combinations used by Boot Block ROM (continued)**

Light *	State	Description
<b>FailSafe Boot Block Mode</b>	<b>Keyboard LED Activity</b>	<b>State/Message</b>
Num, Caps, Scroll Lock	On	Boot Block ROM Flash successful.

\* Diagnostic lights do not flash on USB keyboards.

## Replicating the setup

The following procedures enable you to easily copy one setup configuration to other workstations of the same model to provide faster, more consistent configuration of multiple workstations.

 **NOTE:** Setup configuration procedures require a diskette or a USB such as an HP DriveKey.

To collect and replicate BIOS settings on multiple computers, use System Software Manager or HP Client Manager Software. For more information, see <http://www.hp.com/go/easydeploy>.

### Copying to a single workstation

△ **CAUTION:** A setup configuration is model-specific. File system corruption can result if the source and target workstations are not the same model. For example, do not copy the setup configuration from an HP xw6200 Workstation to an HP xw9400 Workstation.

1. Select a setup configuration to copy, then shut down the workstation.
2. Reboot the workstation.
3. As soon as the screen illuminates, press and hold the **F10** key until you enter the Computer Setup Utility. Press **Enter** to bypass the title screen, if necessary.

 **NOTE:** If you do not press the F10 key at the appropriate time, you must restart the workstation and press and hold the **F10** key again to access the utility.

If you are using a PS2 keyboard, disregard the keyboard error message that might appear.

4. Insert the configuration diskette or USB.
5. Click **File>Replicated Setup>Save to Removable Media**. Follow the instructions on the screen to create the configuration diskette or USB.
6. Power off the workstation to be configured and insert the diskette or USB.
7. Power on the workstation to be configured.
8. As soon as the screen illuminates, press and hold the **F10** key until you enter the Computer Setup Utility. Press **Enter** to bypass the title screen, if necessary.
9. Click **File>Replicated Setup>Restore from Removable Media**, and follow the instructions on the screen.
10. Restart the workstation when the configuration is complete.

### Copying to multiple workstations

△ **CAUTION:** A setup configuration is model-specific. File system corruption can result if the source and target workstations are not the same model. For example, do not copy the setup configuration from an HP xw6200 Workstation to an HP xw9400 Workstation.

This method takes a little longer to prepare the configuration diskette or USB, but copying the configuration to target workstations is significantly faster.

---

 **NOTE:** A bootable diskette or USB is required for this procedure. If Windows XP is not available to create a bootable diskette or USB, use the method for copying to a single workstation instead (see [Copying to a single workstation on page 41](#)).

---

1. Create a bootable diskette or USB.
2. Select a setup configuration to copy, then shut down the workstation.
3. Power on the workstation.
4. As soon as the screen illuminates, press and hold the **F10** key until you enter the Computer Setup Utility. Press **Enter** to bypass the title screen, if necessary.

 **NOTE:** If you do not press the F10 key at the appropriate time, you must restart the workstation and press and hold the **F10** key again to access the utility.

If you are using a PS2 keyboard, disregard the keyboard error message that might appear.

---

5. Insert the diskette or USB.
6. Click **File>Replicated Setup>Save to Removable Media**. Follow the instructions on the screen to create the configuration diskette or USB.
7. Download a BIOS utility for replicating setup (repset.exe), and copy it onto the configuration diskette or USB. To obtain this utility, go to <http://www.hp.com/support/files> and enter the model number of the workstation.
8. On the configuration diskette or USB, create an autoexec.bat file containing the following command: **repset.exe cpqsetup.txt**.
9. Power off the workstation to be configured. Insert the configuration diskette or USB and power on the workstation. The configuration utility runs automatically.
10. Restart the workstation when the configuration is complete.

## Dual-state power button

With ACPI enabled, the power button can function either as an on/off switch or as a sleep button. The feature does not completely remove the power, but instead causes the workstation to enter a low-power standby state. This feature enables you to power off without closing applications and to return to the same operational state without any data loss.

To change the power button configuration:

1. Click **Start**, and select **Control Panel>Power Options**.
2. In **Power Options Properties**, click the **Advanced** tab.
3. In the **Power Button** section, select **Hibernate** or **Standby**. (Hibernate must be enabled in the **Hibernate** tab to use this option.)

After configuring the power button to function as a Hibernate/Standby button, press the power button to put the system in a very low power state. Press the button again to bring the system to full power status.

To completely remove all power to the system, press and hold the power button for four seconds.

---

 **CAUTION:** Do not use the power button to power off the workstation unless the system is not responding. Powering off the power without operating system interaction can cause damage to or loss of data on the hard drive.

---



## Worldwide web site

HP engineers rigorously test and debug software developed by HP and third-party suppliers, and develop operating system specific support software, to ensure performance, compatibility, and reliability for HP workstations.

When making the transition to new or revised operating systems, it is important to implement the support software designed for that operating system. If you plan to run a version of Microsoft Windows that is different from the version included with the workstation, you must install corresponding device drivers and utilities to ensure that all features are supported and functioning properly.

HP has made the task of locating, accessing, evaluating, and installing the latest support software easier. You can download the software from <http://www.hp.com/support>. The Web site contains the latest device drivers, utilities, and flashable ROM images needed to run the latest Microsoft Windows operating system on the HP workstation.

## Building blocks and partners

HP management solutions integrate with other systems management applications, and are based on industry standards, such as:

- Web-Based Enterprise Management (WBEM)
- Windows Management Interface (WMI)
- Wake on LAN technology
- ACPI
- SMBIOS
- Pre-boot Execution Environment (PXE) support
- Alert Standard Format

## Asset tracking and security

Asset tracking features incorporated into the workstation provide key asset tracking data that can be managed using HP Systems Insight Manager, HP Client Manager Software, or other system management applications. Seamless, automatic integration between asset tracking features and these products enables you to choose the management tool that is best suited to the environment and to leverage the investment in existing tools.

HP also offers several solutions for controlling access to valuable components and information. ProtectTools Embedded Security, if installed, prevents unauthorized access to data, checks system integrity, and authenticates third-party users attempting system access. Security features such as ProtectTools and the Hood Sensor (Smart Cover Sensor) help to prevent unauthorized access to your data and to the internal components of the workstation. By disabling parallel, serial, or USB ports, or by disabling removable media boot capability, you can protect valuable data assets. Memory Change and Hood Sensor (Smart Cover Sensor) alerts can be automatically forwarded to system management applications to deliver proactive notification of tampering with a workstation's internal components.

 **NOTE:** ProtectTools, the Hood Sensor (Smart Cover Sensor), and the Hood Lock (Smart Cover Lock) are available as options on select systems.

Use the following utilities to manage security settings on the HP workstation:

- Computer Setup (F10) Utility (local).
- HP Client Manager Software or System Software Manager (remote). This software enables the secure, consistent deployment and control of security settings from a simple command line utility.

The following table and sections refer to managing security features of the workstation locally through the Computer Setup Utility.

**Table 4-3 Security features overview**

Feature	Purpose	How It Is Established
Removable Media Boot Control	Prevents booting from the removable media drives.	Computer Setup Utility Menu.
Serial, Parallel, USB, or Infrared Interface Control	Prevents transfer of data through the integrated serial or USB interfaces.	Computer Setup Utility menu.
Power-On Password	Prevents use of the workstation until the password is entered. This can apply to both initial system startup and restarts.	Computer Setup Utility menu.
Setup Password	Prevents reconfiguration of the workstation (use of the Setup - Utilities) until the password is entered.	Computer Setup Utility menu.
Network Server Mode	Provides unique security features for workstations being used as servers.	Computer Setup Utility menu.
Ownership Tag	Displays ownership information, as defined by the system administrator, during system startup (protected by setup password).	Computer Setup Utility menu.
Kensington Cable Lock Provision	Prevents entire system theft only.	Install a Kensington cable lock to secure the workstation to a fixed object.
Padlock Loop	Prevents access panel from being removed. This loop can also be used to secure the unit to a fixed object.	Install a padlock.
Access Panel Key Lock (Standard)	Prevents removal of the access panel and all internal components including optical and floppy drives	Lock the access panel.
Universal Chassis Clamp Lock (Optional)	The version without a cable discourages access panel removal and prevents the theft of I/O devices. The version with a cable additionally prevents entire system theft and allows multiple systems to be secured with a single cable.	Install a chassis clamp lock.
Hood Sensor	Notifies a local or remote user when the chassis access panel has been opened.	Install an intrusion sensor.

**NOTE:** For more information about the Computer Setup Utility, see [Computer Setup \(F10\) Utility menu on page 28](#).

## Password security

The power-on password prevents unauthorized use of the workstation by requiring entry of a password to access applications or data each time the workstation is turned on or restarted. The setup password specifically prevents unauthorized access to the Computer Setup Utility and can also be used as an override to the power-on password. That is, when prompted for the power-on password, entering the setup password instead will allow access to the workstation.

A network-wide setup password can be established to enable the system administrator to log in to all network systems to perform maintenance without having to know the power-on password.

 **NOTE:** System Software Manager and HP Client Manager Software allow remote management of setup passwords and other BIOS settings in a networked environment. For more information, see <http://www.hp.com/go/easydeploy>.

### Establishing a setup password in the Computer Setup (F10) Utility

Establishing a setup password through the Computer Setup Utility prevents reconfiguration of the workstation (through use of the Computer Setup Utility) until the password is entered.

To establish a setup password using workstation setup:

1. Power on or restart the workstation.
2. As soon as the screen illuminates, press and hold **F10** until you enter the Computer Setup Utility. Press **Enter** to bypass the title screen, if necessary.

 **NOTE:** If you do not press the F10 key at the appropriate time, you must restart the workstation and press and hold the **F10** key again to access the utility.

If you are using a PS2 keyboard, disregard the keyboard error message that might appear.

3. Select **Security>Setup Password**, and follow the onscreen instructions.
4. Before exiting, select **File>Save Changes and Exit**.

### Establishing a power-on password in the Computer Setup (F10) Utility

Establishing a power-on password through the Computer Setup Utility prevents access to the workstation when power is on, unless the password is entered. When a power-on password is set, the Computer Setup Utility presents Password Options under the Security menu. The password options include Network Server Mode and Password Prompt on Warm Boot.

When Network Server Mode is disabled, the password must be entered each time the workstation is powered on when the key icon appears on the monitor. When Password Prompt on Warm Boot is enabled, the password must also be entered each time the workstation is rebooted. When Network Server Mode is enabled, the password prompt is not presented during POST, but any attached PS2 keyboard remains locked until the power-on password is entered.

To enable Network Server Mode, a power-on password must be set. The option then shows up under **Advanced>Password Options**. This feature allows the system to boot without asking for the power-on password, but the keyboard and mouse are locked until you enter it. The keyboard LEDs rotate constantly when the system is in locked mode

To establish a power-on password through workstation setup:

1. Power on or restart the workstation.
2. As soon as the screen illuminates, press and hold the **F10** until you enter the Computer Setup Utility. Press **Enter** to bypass the title screen, if necessary.

 **NOTE:** If you do not press the F10 key at the appropriate time, you must restart the workstation and press and hold the **F10** key again to access the utility.

If you are using a PS2 keyboard, disregard the keyboard error message that might appear.

3. Select **Security>Power-On Password**, and follow the onscreen instructions.
4. Before exiting, select **File>Save Changes and Exit**.

## Entering a power-on password

To enter a power-on password:

1. Power on or restart the workstation.
2. When the key icon appears on the monitor, enter the current password, and press **Enter**.

 **NOTE:** Type carefully. For security reasons, the characters you enter do not appear on the screen.

If you enter the password incorrectly, a broken key icon appears. Try again. After three unsuccessful tries, you must restart the workstation before you can continue.

## Entering a setup password

If a setup password has been established on the workstation, you will be prompted to enter it each time you run the Computer Setup Utility.

To enter a setup password:

1. Power on or restart the workstation.
2. As soon as the screen illuminates, press and hold the **F10** key until you enter the Computer Setup Utility. Press **Enter** to bypass the title screen, if necessary.

 **NOTE:** If you do not press the F10 key at the appropriate time, you must restart the workstation and press and hold the **F10** key again to access the utility.

If you are using a PS2 keyboard, disregard the keyboard error message that might appear.

3. When the key icon appears on the monitor, enter the setup password, and press **Enter**.

 **NOTE:** Type carefully. For security reasons, the characters you enter do not appear on the screen.

If you enter the password incorrectly, a broken key icon appears. Try again. After three unsuccessful tries, you must restart the workstation, before you can continue.

## Changing a power-on or setup password

To change a power-on or setup password:

1. Power on or restart the workstation.
2. As soon as the screen illuminates, press and hold the **F10** key until you enter the Computer Setup Utility. Press **Enter** to bypass the title screen, if necessary.

 **NOTE:** If you do not press F10 at the appropriate time, you must restart the workstation and press and hold the **F10** key again to access the utility.

If you are using a PS2 keyboard, disregard the keyboard error message that might appear.

3. When the key icon appears, enter the current password, a slash (/) or alternate delimiter character, your new password, another slash (/) or alternate delimiter character, and your new password again as shown: **current password/new password/new password**

 **NOTE:** Type carefully. For security reasons, the characters you enter do not appear on the screen.

4. Press **Enter**.

The new password takes effect the next time you power on the workstation.

 **NOTE:** See the table of [National keyboard delimiter characters on page 47](#) for information about the alternate delimiter characters. The power-on password and setup password can also be changed using the Security menu in the Computer Setup Utility.

## Deleting a power-on or setup password

To delete a power-on or setup password:

1. Power on or restart the workstation.
2. To delete the power-on password, go to step 3.

To delete the setup password, as soon as the screen illuminates, press and hold the **F10** key until you enter the Computer Setup Utility. Press **Enter** to bypass the title screen, if necessary.

 **NOTE:** If you do not press the F10 key at the appropriate time, you must restart the computer and press and hold the **F10** key again to access the utility.

Use the appropriate operating system shutdown process.

3. When the key icon appears, enter your current password followed by a slash (/) or alternate delimiter character as shown: *current password/*.
4. Press **Enter**.

 **NOTE:** See the [National keyboard delimiter characters on page 47](#) for information about the alternate delimiter characters. The power-on password and setup password can also be changed using the Security menu in the Computer Setup Utility.

## National keyboard delimiter characters

Each keyboard is designed to meet country-specific requirements. The syntax and keys that you use for changing or deleting your password depend on the keyboard that came with your workstation.

**Table 4-4 National keyboard delimiter characters**

<b>Arabic</b>	<b>/</b>	<b>Greek</b>	<b>-</b>	<b>Russian</b>	<b>/</b>
Belgian	=	Hebrew	.	Slovakian	-
BHCSY*	-	Hungarian	-	Spanish	-
Brazilian	/	Italian	-	Swedish/Finnish	/
Chinese	/	Japanese	/	Swiss	-
Czech	-	Korean	/	Taiwanese	/
Danish	-	Latin American	-	Thai	/
French	!	Norwegian	-	Turkish	.
French Canadian	é	Polish	-	U.K. English	/
German	-	Portuguese	-	U.S. English	/

\* For Bosnia-Herzegovina, Croatia, Slovenia, and Yugoslavia.

## Clearing passwords

If you forget your password, you cannot access the workstation. See [Resetting the password jumper on page 189](#) for instructions on clearing passwords.

## Hood sensor (Smart Cover Sensor)

The optional hood sensor is a combination of hardware and software technology that can alert you when the workstation side access panel has been removed. There are three levels of protection, as described in the following table.

**Table 4-5 Hood sensor protection levels \***

Level	Setting	Description
Level 0	Disabled	Hood sensor is disabled (default).
Level 1	Notify User	When the workstation is restarted, the screen displays a message indicating that the workstation side access panel has been removed.
Level 2	Setup Password	When the workstation is restarted, the screen displays a message indicating that the workstation side access panel has been removed. You must enter the setup password to continue.

\* These settings can be changed using the Computer Setup Utility.

### Setting the hood sensor protection level

To set the hood sensor protection level:

1. Power on or restart the workstation.
2. As soon as the screen illuminates, press and hold the **F10** key until you enter the Computer Setup Utility. Press **Enter** to bypass the title screen, if necessary.

 **NOTE:** If you do not press the F10 key at the appropriate time, you must restart the computer and press and hold the **F10** key again to access the utility.

If you are using a PS2 keyboard, disregard the keyboard error message that might appear.

3. Select **Security>Smart Cover>Cover Removal Sensor**, then side access panel, and follow the onscreen instructions.
4. Select **File>Save Changes and Exit**.

### Cable lock provision (optional)

The rear panel of the chassis can accommodate a cable lock accessory that allows the workstation to be physically secured to a work area.

### Security lock (optional)

This optional feature prevents entire system theft and discourages access panel removal.

### Universal chassis clamp lock (optional)

The version without a cable discourages access panel removal and prevents theft of I/O devices. The version with a cable also prevents entire system theft and allows multiple systems to be secured with a single cable.

## Access panel key lock

This lock prevents removal of the access panel and all internal components. The key is shipped on the rear of the workstation.

## Fault notification and recovery

Fault notification and recovery features combine innovative hardware and software technology to prevent the loss of critical data and minimize unplanned downtime.

If the workstation is connected to a network managed by HP Client Manager software, the computer sends a fault notice to the network management application. With HP Client Manager software, you can also remotely schedule diagnostics to automatically run on all managed PCs and create a summary report of failed tests.

## Drive Protection System

The Drive Protection System (DPS) is a diagnostic tool built into the hard drives installed in select HP workstations. DPS is designed to help diagnose problems that might result in unwarranted hard drive replacement.

When HP workstations are built, each installed hard drive is tested using DPS, and a permanent record of key information is written onto the drive. Each time DPS is run, test results are written to the hard drive. The service provider can use this information to help diagnose conditions that caused you to run the DPS software.

## ECC fault prediction and pre-failure warranty

When the workstation encounters an excessive number of error checking and correcting (ECC) memory errors, it displays a Local Alert message. This message contains detailed information about the errant memory module, enabling you to take action before you experience un-correctable memory errors. The pre-failure warranty for ECC memory modules enables you to replace these modules, free of charge, before the modules actually fail. ECC memory modules are supported on current HP workstations.

## Thermal sensors

A thermal sensor is a hardware and software feature that tracks temperature. When combined with HP Client Manager Software, a thermal sensor notifies the network administrator when a normal temperature range is exceeded. For example, a thermal sensor monitors processor temperature. If processor temperature remains too high, the system eventually shuts down.



---

# 5 Removal and replacement procedures

This chapter describes removal and replacement procedures of most internal components.

- [Warnings and cautions on page 50](#)
- [Service considerations on page 51](#)
- [Customer Self Repair on page 55](#)
- [Pre-disassembly procedures on page 55](#)
- [System board components on page 56](#)
- [System board architecture on page 57](#)
- [Removing and replacing components on page 58](#)
- [Product recycling on page 121](#)

## Warnings and cautions

- 
- ⚠ **WARNING!**  Any surface or area of the equipment marked with this symbol indicates the presence of a hot surface or hot component. If this surface is contacted, the potential for injury exists. To reduce the risk of injury from a hot component, enable the surface to cool before touching.
- 
- ⚠ **WARNING!**  Any surface or area of the equipment marked with this symbol indicates the presence of an electrical shock hazard. To reduce the risk of injury from electrical shock, do not open any enclosed area marked with this symbol.
- 
- ⚠ **WARNING!** To reduce the risk of electric shock or damage to your equipment:
- Do not disable the power cord grounding plug. The grounding plug is an important safety feature.
  - Plug the power cord in a grounded (earthed) outlet that is easily accessible at all times.
  - Disconnect power from the equipment by unplugging the power cord from the electrical outlet.
- 
- ⚠ **WARNING!** To reduce the risk of serious injury, read the *Safety & Comfort Guide*. It describes proper workstation setup, posture, health, and work habits for computer users, and provides important electrical and mechanical safety information. This guide is located at <http://www.hp.com/ergo> and on the documentation CD (if one is included with the product).
- 
- ⚠ **WARNING!** If a product is shipped in packaging marked with this symbol, , the product must always be lifted by two persons to avoid personal injury due to product weight.
- 
- ⚠ **CAUTION:** Static electricity can damage the electronic components of the workstation. Before beginning these procedures, be sure you discharge static electricity by briefly touching a grounded metal object.
-



- 
- △ **CAUTION:** Observe the following cautions when removing or replacing a processor:
- Installing a processor incorrectly can damage the system board. Contact an HP authorized reseller or service provider to install the processor. If you plan to install the processor yourself, read all of the instructions carefully before you begin.
  - Failure to follow the workstation preparation instructions can result in an improperly installed processor, causing extensive workstation damage.
  - Processor socket pins are delicate and bend easily. Use extreme care when placing the processor in the socket.
- 
- △ **CAUTION:** To prevent damage to the workstation, observe the following Electrostatic Discharge (ESD) precautions while performing the system parts removal and replacement procedures:
- Work on a static-free mat.
  - Wear a static strap to ensure that any accumulated electrostatic charge is discharged from your body to the ground.
  - Create a common ground for the equipment you are working on by connecting the static-free mat, static strap, and peripheral units to that piece of equipment.
- 
- 📖 **NOTE:** HP accessories are for use in HP Workstation products. They have been extensively tested for reliability and are manufactured to high quality standards.
- 

## Service considerations

The following sections discuss service considerations that should be reviewed and practiced before removing and replacing any system components.

- △ **WARNING!** When lifting or moving the workstation, do not use the front bezel as a handle or lifting point. Lifting the workstation from the front bezel or lifting it incorrectly can cause the unit to fall and harm the user and damage the workstation. To properly and safely lift the workstation, lift it from the bottom of the unit.
- 

## Read cautions, warnings, and safety precautions

For your safety, review the cautions, warnings, and safety precautions before accessing the components of the workstation. Also, review the *Safety and Regulatory Guide* that came with your workstation for more information.

- △ **WARNING!** Some parts inside the computer will be hot. Power off and unplug the system, and wait three to five minutes for them to cool before opening the system access panels or touching internal components.
- 

## Electrostatic discharge information

A sudden discharge of static electricity from your finger or other conductor can destroy static-sensitive devices or microcircuitry. Often the spark is neither felt nor heard, but damage occurs. An electronic device exposed to electrostatic discharge (ESD) might not appear to be affected at all and can work perfectly throughout a normal cycle. The device can function normally for a while, but it has been degraded in the internal layers, reducing its life expectancy.

Networks built into many integrated circuits provide some protection, but in many cases, the discharge contains enough power to alter device parameters or melt silicon junctions.

## Generating static

The following table shows that different activities generate different amounts of static electricity. Static electricity increases as humidity decreases.

**Table 5-1 Static electricity**

Event	Relative Humidity		
	5%	4%	1%
Walking across carpet	7,500 V	15,000 V	35,000 V
Walking across vinyl floor	3,000 V	5,000 V	12,000 V
Motions of bench worker	400 V	800 V	6,000 V
Removing bubble pack from PCB	7,000 V	20,000 V	26,500 V
Packing PCBs in foam-lined box	5,000 V	11,000 V	21,000 V

△ **CAUTION:** 700 volts can degrade a product.

## Preventing electrostatic damage to equipment

Many electronic components are sensitive to ESD. Circuitry design and structure determine the degree of sensitivity. The following packaging and grounding precautions are necessary to prevent damage to electric components and accessories.

- Transport products in static-safe containers, such as tubes, bags, or boxes, to avoid hand contact.
- Protect all electrostatic parts and assemblies with conductive or approved containers or packaging.
- Keep electrostatic-sensitive parts in their containers until they arrive at static-free stations.
- Place items on a grounded surface before removing them from their containers.
- When handling or touching a sensitive component or assembly, ground yourself by touching the chassis.
- Avoid contact with pins, leads, or circuitry.
- Place reusable electrostatic-sensitive parts from assemblies in protective packaging or conductive foam.

## Personal grounding methods and equipment

Use the following equipment to prevent static electricity damage to equipment:

- Wrist straps are flexible straps with a maximum of one megohm  $\pm$  10% resistance in the ground cords. To provide a proper ground, wear the strap against bare skin. The ground cord must be connected and fit snugly into the banana plug connector on the grounding mat or workstation.
- Heel straps, toe straps, and boot straps can be used at standing workstations and are compatible with most types of shoes or boots. On conductive floors or dissipative floor mats, use them on both feet with a maximum of one-megohm  $\pm$  10% resistance between the operator and ground.

**Table 5-2 Static shielding protection levels**

Method	Voltage
Antistatic plastic	1,500
Carbon-loaded plastic	7,500
Metallized laminate	15,000

## Grounding the work area

To prevent static damage at the work area:

- Cover the work surface with approved static-dissipative material. Provide a wrist strap connected to the work surface and properly grounded tools and equipment.
- Use static-dissipative mats, foot straps, or air ionizers to give added protection.
- Handle electrostatic sensitive components, parts, and assemblies by the case or PCB laminate. Handle them only at static-free work areas.
- Turn off power and input signals before inserting and removing connectors or test equipment
- Use fixtures made of static-safe materials when fixtures must directly contact dissipative surfaces.
- Keep work area free of nonconductive materials, such as ordinary plastic assembly aids and Styrofoam.
- Use field service tools, such as cutters, screwdrivers, and vacuums, that are conductive.

## Recommended materials and equipment

It is recommended that the following materials and equipment be used to prevent static electricity:

- Antistatic tape
- Antistatic smocks, aprons, or sleeve protectors
- Conductive bins and other assembly or soldering aids
- Conductive foam
- Conductive tabletop workstations with ground cord of one-megohm  $\pm$  10% resistance
- Static-dissipative table or floor mats with hard tie to ground
- Field service kits
- Static awareness labels

- Wrist straps and footwear straps providing one-megohm  $\pm$  10% resistance
- Material handling packages
- Conductive plastic bags and tubes
- Conductive tote boxes
- Opaque and transparent metallized shielded bags
- Transparent shielding tubes

## Required tools and software

The following tools and software are required to service your workstation:

- Torx T-15 screwdriver or flathead screwdriver
- Diagnostics software

## Screws

The screws used in the workstation are not interchangeable. They might have standard or metric threads and might be of different lengths. If an incorrect screw is used during the reassembly process, it can damage the unit. HP strongly recommends that all screws removed during disassembly be kept with the removed part and then returned to their proper locations.

## Special handling of components

The following components require special handling when servicing the workstation.

### Cables and connectors

Cables must be handled with care to avoid damage. Apply only the tension required to seat or unseat the cables during insertion or removal from the connector. Handle cables by the connector or pull strap whenever possible. In all cases, avoid bending or twisting the cables, and be sure that the cables are routed in such a way that they cannot be caught or snagged by parts being removed or replaced.

**△ CAUTION:** When servicing this workstation, be sure that cables are placed in their proper location during the reassembly process. Improper cable placement can damage the workstation.

### Hard drives

Handle hard drives as delicate, precision components, avoiding all physical shock and vibration. This guideline applies to failed drives and replacement spares. Keep the following guidelines in mind as well:

- If a drive must be mailed, place the drive in a bubble-pack mailer or other suitable protective packaging and label the package “Fragile: Handle With Care.”
- Do not remove hard drives from the shipping package for storage. Keep hard drives in their protective packaging until they are actually mounted in the workstation.
- Avoid dropping drives from any height onto any surface.
- If you are inserting or removing a hard drive, power off the workstation. Do not remove a hard drive while the workstation is on.
- Before handling a drive, be sure that you are discharged of static electricity. While handling a drive, avoid touching the connector. For more information about preventing electrostatic damage, see [Electrostatic discharge information on page 51](#).

- Do not use excessive force when inserting a drive.
- Avoid exposing a hard drive to liquids, temperature extremes, or products that have magnetic fields such as monitors or speakers.

## Lithium coin cell battery

The battery that comes with the workstation provides power to the real-time clock and has a minimum lifetime of about three years.

For instructions on battery removal and replacement, see [Battery on page 88](#).

 **WARNING!** This workstation contains a lithium battery. A risk of fire and chemical burn exists if the battery is handled improperly. Do not disassemble, crush, puncture, short external contacts, dispose of in water or fire, or expose it to temperatures higher than 140 degrees F (60 degrees C).

 **NOTE:** Batteries, battery packs, and accumulators should not be disposed of with general household waste.

## Customer Self Repair

Customer Self Repair (CSR) enables you to obtain replacement parts and install them yourself on your workstation. See <http://www.hp.com/go/selfrepair/> for more information.

## Pre-disassembly procedures

After shutdown, perform the following steps before servicing the workstation:

1. Remove or disengage any security devices that prohibit opening the workstation.
2. Close any open software applications.
3. Remove any diskettes or CDs from the workstation.
4. Exit the operating system.
5. Shut down the workstation and any peripheral devices that are connected to it.
6. Disconnect the power cord from the electrical outlet and then from the workstation.
7. Disconnect all peripheral device cables from the workstation.

# System board components

The following image shows the system board connectors and sockets on the HP xw9400 Workstation.

**Figure 5-1** System board identification

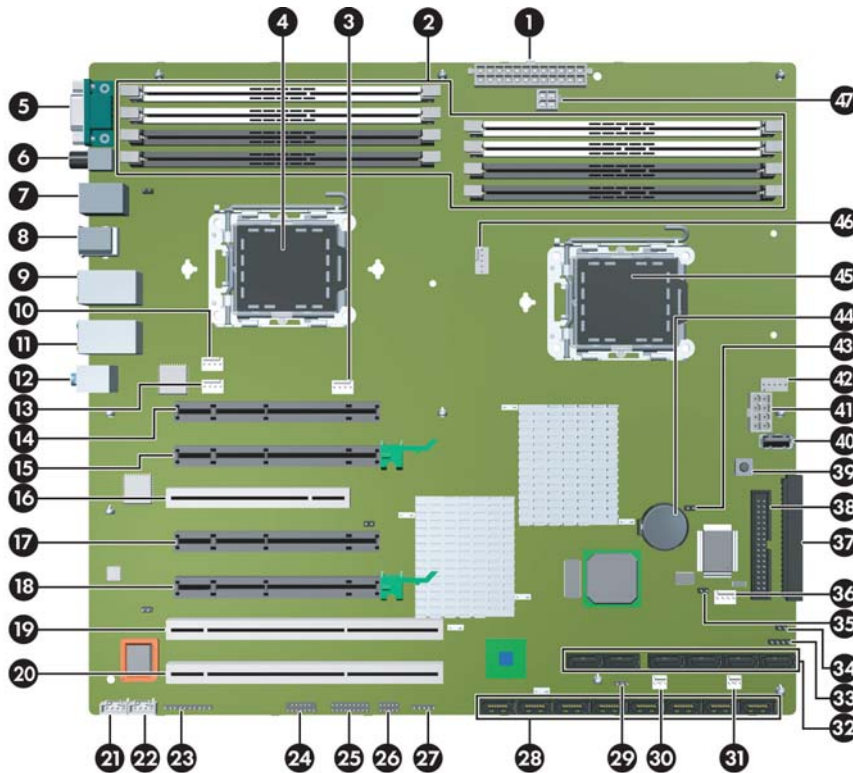

**Table 5-3** System board components

Item	Description	Item	Description	Item	Description	Item	Description
1	Main power	13	Memory fan	25	Front control panel	37	Primary IDE**
2	Memory module pairs	14	PCI Express x16 (x8 performance)*	26	Front USB	38	Diskette drive
3	Voltage regulator fan (Liquid Cooling Unit)	15	PCI Express x16 graphics	27	Internal USB 0	39	Clear CMOS button
4	CPU1	16	PCI 32 bit, 33 MHz	28	Serial SCSI (SAS)	40	Internal USB 1
5	Serial	17	PCI Express x16 (x8 performance)*	29	PCI-X speed jumper	41	Processor power jumper
6	SPDIF Out	18	PCI Express x16	30	Spare 12V fan	42	CPU0 fan
7	PS/2 keyboard/mouse	19	PCI-X 100	31	Spare 12V fan	43	Fan detection jumper
8	IEEE 1394/USB	20	PCI-X 100/133	32	Serial ATA (SATA)	44	Battery

**Table 5-3 System board components (continued)**

Item	Description	Item	Description	Item	Description	Item	Description
9	LAN/USB	21	CD audio	33	Hard disk activity LED	45	CPU0
10	Chassis fan	22	Auxiliary audio	34	Password jumper	46	CPU1 fan
11	LAN/USB	23	Front audio	35	Crisis recovery jumper	47	Memory power jumper
12	Audio	24	Front IEEE 1394	36	PCI fan		

\* The PCI Express x16 is a PCI Express x16 connector that has x8 bandwidth.

\*\* The Primary IDE connector is generally used for optical drives.

## System board architecture

The following image shows the HP xw9400 Workstation block diagram.

**Figure 5-2 System board block diagram**

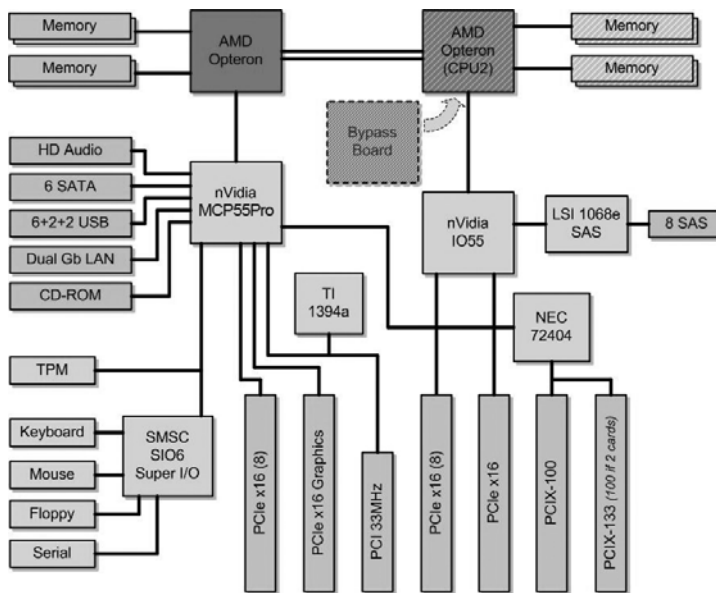

# Removing and replacing components

This section discusses the procedures necessary to remove and install various hardware components on your workstation.

Before servicing or upgrading your workstation:

1. Review the safety precautions and the [Service considerations on page 51](#), as well as the *Safety and Regulatory Information*.
2. Locate and clear a suitable work area.
3. Shut down the system and remove power from the unit.
4. Gather your tools.
5. Remove all security devices.
6. Service your unit.
7. Restore power to your unit.

---

 **NOTE:** Prior to removing and replacing a component, make sure you remove all installed components that obstruct or prevent the removal of the component.

If you are unsure how to remove a particular component, please do one of the following:

1. Refer to the appropriate section in this chapter.
  2. If the content you desire is not referenced in this chapter, see [www.hp.com/support/xw9400\\_manuals](http://www.hp.com/support/xw9400_manuals) and look under “Setup and Install – General” for instructions.
  3. See the manufacturer’s web site for instructions for a third party (non-HP) component.
-



## Disassembly order

Use the following table to determine the sequence in which to remove the major components.

Pre-disassembly ( <a href="#">Pre-disassembly procedures on page 55</a> )
Locks ( <a href="#">Security lock (optional) on page 61</a> )
Access panel ( <a href="#">Access panel on page 63</a> )
Hood sensor ( <a href="#">Hood sensor (Smart cover sensor) on page 65</a> )
Front bezel ( <a href="#">Front bezel on page 64</a> )
Front panel I/O device assembly ( <a href="#">Front panel I/O device assembly on page 66</a> )
Power button and front speaker ( <a href="#">Power button assembly and system speaker on page 67</a> )
Optical drive ( <a href="#">Optical drive on page 90</a> )
Diskette drive ( <a href="#">Diskette drive (optional) on page 93</a> )
Bezel blanks ( <a href="#">Bezel blanks on page 64</a> )
Power supply ( <a href="#">Power supply on page 69</a> )
System fan ( <a href="#">System fan on page 70</a> )
Memory fan ( <a href="#">Memory fan on page 71</a> )
Memory ( <a href="#">Memory on page 72</a> )
Front fan removal (optional) ( <a href="#">Front fan removal on page 84</a> )
Battery ( <a href="#">Battery on page 88</a> )

Hard drive ( <a href="#">Hard drive on page 95</a> )
CPU heatsink ( <a href="#">Removing the CPU heatsink on page 113</a> )
Processor ( <a href="#">Removing the processor on page 117</a> )
PCI retainer ( <a href="#">PCI retainer on page 78</a> )
PCI retention clamp ( <a href="#">PCI retention clamp on page 80</a> )
PCI or PCI Express card ( <a href="#">Removing PCI or PCI Express cards on page 82</a> )
CPU heatsink ( <a href="#">Removing the CPU heatsink on page 113</a> )
Processor ( <a href="#">Removing the processor on page 117</a> )
System board ( <a href="#">System board on page 120</a> )

## Security lock (optional)

If a security padlock is installed, remove it before servicing the unit. To remove the padlock, unlock it and slide it out of the padlock loop as shown in the following image.

**Figure 5-3** Removing the security lock



## Cable lock (optional)

If a cable lock is installed, remove it before servicing the unit. To remove the cable lock, unlock it and pull it out of the cable lock slot as shown in the following image.

**Figure 5-4** Removing the cable lock



## Universal chassis clamp lock (optional)

If a universal chassis clamp lock is installed, remove it before servicing the unit.

To remove the lock:

1. Unlock the device and remove the locking mechanism.



2. Remove the screw attaching the lock to the chassis.



## Access panel

Before accessing the internal components of the workstation, the access panel must be removed.

To remove the access panel:

**⚠ WARNING!** Before removing the workstation access panel, be sure that the workstation is powered off and that the power cord is disconnected from the electrical outlet.

1. Disconnect power from the system.
2. If a lock is present, unlock the access panel. The keys are on the rear panel ([Rear panel components on page 4](#)). Also, unlock any other locks that are present (Kensington, or Padlock).
3. Pull up on the handle and lift off the cover.

**Figure 5-5** Opening the access panel



To replace the access panel, align the bottom groove of the access panel with the bottom edge of the chassis. Rotate the access panel toward the chassis and press firmly until the latch engages.

## Front bezel

To remove the front bezel:

1. Lift up on the three (1) tabs located on the front bezel.
2. Rotate the front bezel away (2) from the chassis, and remove the bezel.

**Figure 5-6** Opening the front bezel



## Bezel blanks

To remove the bezel blanks:

1. Disconnect power from the system, ([Pre-disassembly procedures on page 55](#)), remove the access panel, and remove the front bezel ([Front bezel on page 64](#))
2. Remove the bezel blanks by squeezing in on the tabs (1) and pulling in the bezel blanks (2).

**Figure 5-7** Removing the bezel blanks

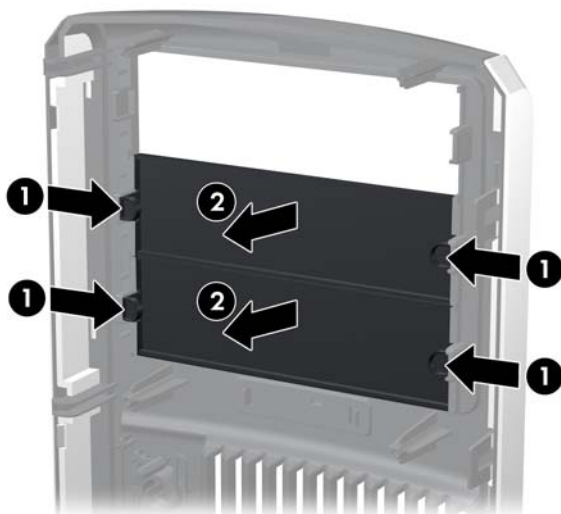

## Hood sensor (Smart cover sensor)

To remove the hood sensor:

1. Disconnect power from the system ([Pre-disassembly procedures on page 55](#)) and remove the access panel ([Access panel on page 63](#)). Remove the front bezel. Lay the workstation on its side with the system board facing up.
2. Remove the two hood sensor bracket screws, and remove the bracket and sensor as a unit.

**Figure 5-8** Removing the hood sensor

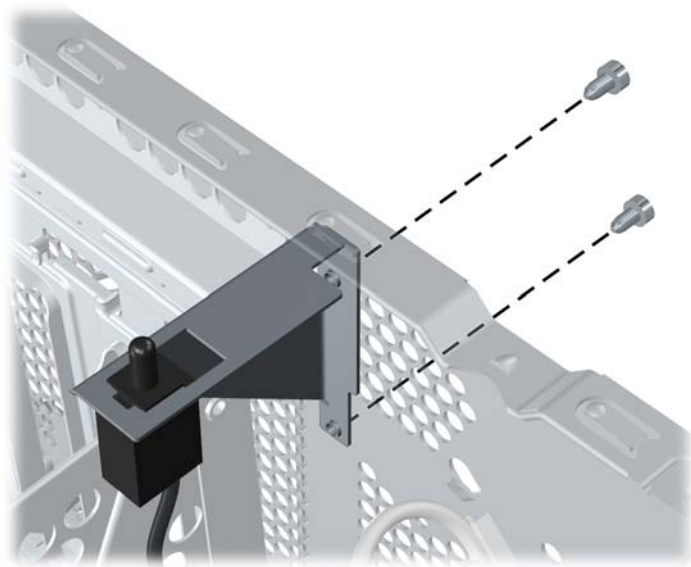

To replace the hood sensor, reverse the previous steps.

## Front panel I/O device assembly

To remove the front panel I/O device assembly:

1. Disconnect power from the system ([Pre-disassembly procedures on page 55](#)). Remove the access panel ([Access panel on page 63](#)) and the front bezel ([Front bezel on page 64](#)).
2. Unlatch the plastic snap that secures the cables inside the chassis and, disconnect the front panel I/O device assembly cables from the system board.
3. Remove the screws that hold the front panel I/O device assembly and bracket to the chassis, and remove the screws that hold the front panel I/O device assembly to the bracket.
4. Pull the front panel I/O device assembly out about two inches away from the chassis.
5. Pull the bracket away from the front panel I/O device assembly.

**Figure 5-9** Removing the front panel I/O device assembly

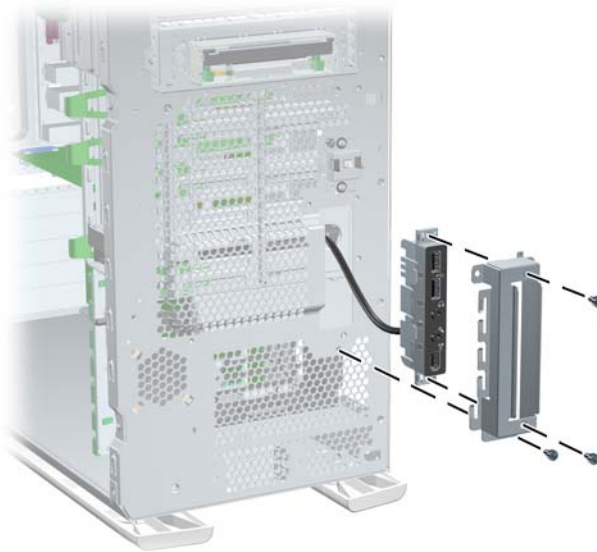

6. Slide the front panel cables through the chassis and out the front of the unit.

To replace the front panel I/O device assembly, reverse the previous steps.



## Power button assembly and system speaker

The power button and the system speaker are part of the same assembly.

To remove the power button:

1. Disconnect power from the system ([Pre-disassembly procedures on page 55](#)) and remove the access panel ([Access panel on page 63](#)).
2. Remove the front bezel ([Front bezel on page 64](#)) and the front panel I/O device assembly ([Front panel I/O device assembly on page 66](#)).
3. Disconnect the power button assembly cable from the system board.
4. Disconnect the speaker wire and the hood sensor from the inline connectors on the power button assembly cable.
5. Remove the screw (1) that secures the power button assembly to the chassis.
6. Dislodge the metal clip from the chassis by rocking the power button back and forth. Then slide the power button assembly (2) out from the front of the chassis.

**Figure 5-10** Removing the power button assembly

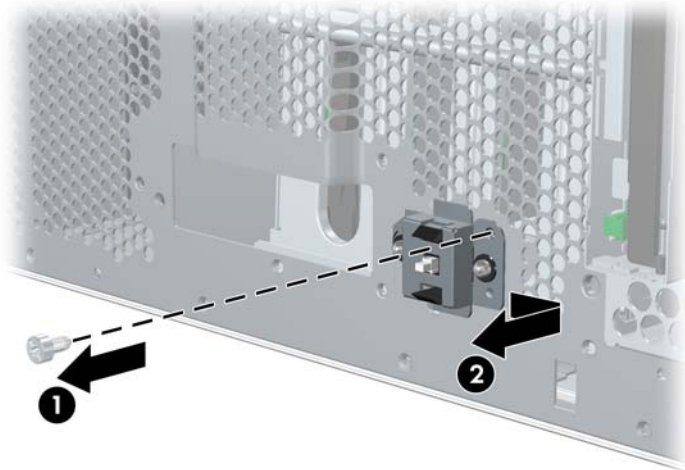

To remove the speaker:

1. Disconnect the speaker cable from the in-line front panel I/O device assembly cable, if you have not already done so.

2. Slide the speaker away from the three flanges and remove it from the chassis.

**Figure 5-11** Removing the speaker

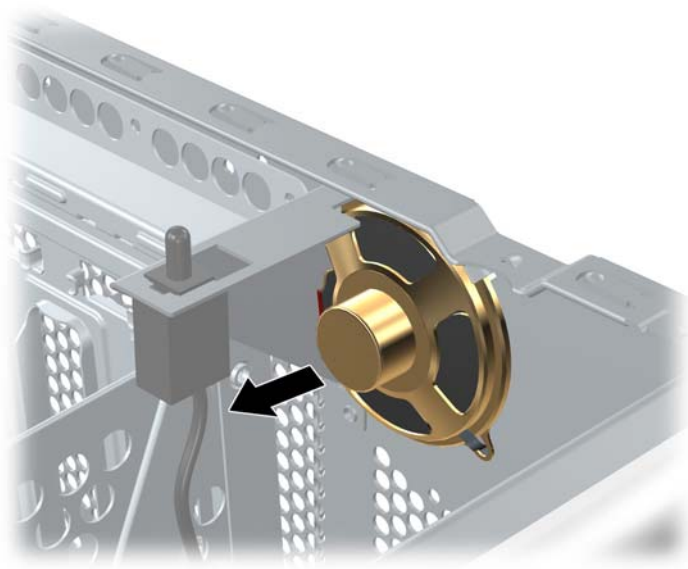

## Power supply

1. Disconnect power from the system ([Pre-disassembly procedures on page 55](#)), and remove the access panel ([Access panel on page 63](#)). Place the workstation on its side with the system board facing up.
2. Disconnect the three power supply cable connectors from the system board.

 **NOTE:** Cable ties and cable clips may be present.

3. Disconnect the power supply connections from the optical drives, diskette drive, hard drives, and graphics card (select models only).
4. Remove the four screws (1) from the back panel.
5. Slide the power supply toward the front, and lift up (2) to remove it from the chassis.

**Figure 5-12** Removing the power supply

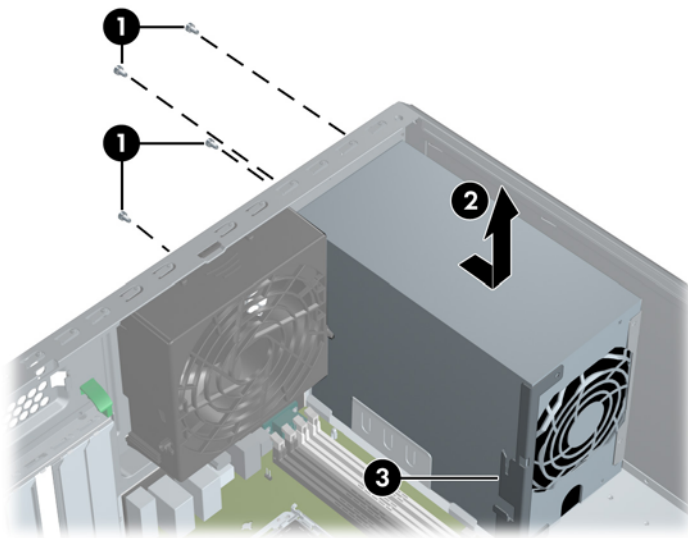

To install the power supply, reverse the previous steps. If you're installing a new power supply, be sure to move the memory fan bracket (3) from the old power supply to the new one.

## System fan

To remove the system fan:

1. Disconnect power from the system ([Pre-disassembly procedures on page 55](#)), and remove the access panel ([Access panel on page 63](#)). Place the workstation on its side with the system board facing up.
2. Disconnect the fan power plug from the system board (1).
3. Press down on the ribbed portion of the system fan housing (2), rotate the fan housing down, and lift the unit out of the chassis.

**Figure 5-13** Removing the system fan

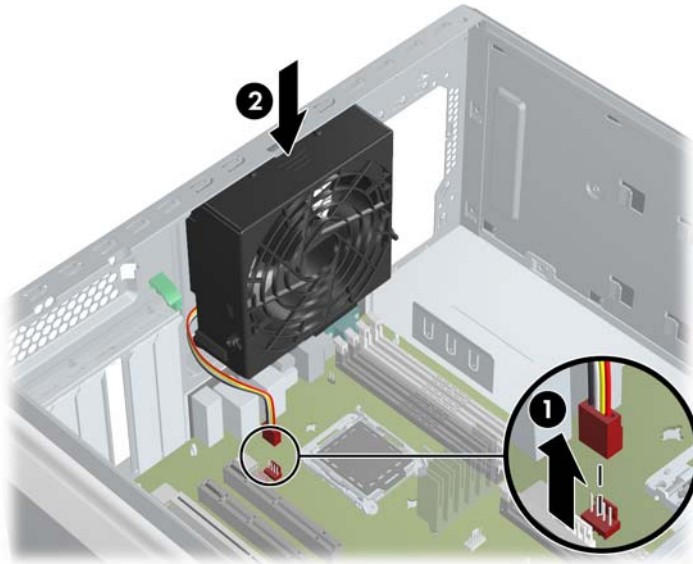

To replace the system fan, reverse the previous steps.

- △ **CAUTION:** When installing the system fan, be sure that the fan is situated so that the airflow direction is going out of the chassis to avoid overheating.

## Memory fan

To remove the memory fan:

1. Disconnect power from the system ([Pre-disassembly procedures on page 55](#)), and remove the access panel ([Access panel on page 63](#)). Place the workstation on its side with the system board facing up.
  2. Disconnect the memory fan power plug from the system board (1).
-  **NOTE:** If the fan is simply being moved to access the DIMMs, it does not need to be disconnected from the system board.
3. Press the tab in on the memory fan housing (2) and lift the unit out of the chassis (3).

**Figure 5-14** Removing the memory fan

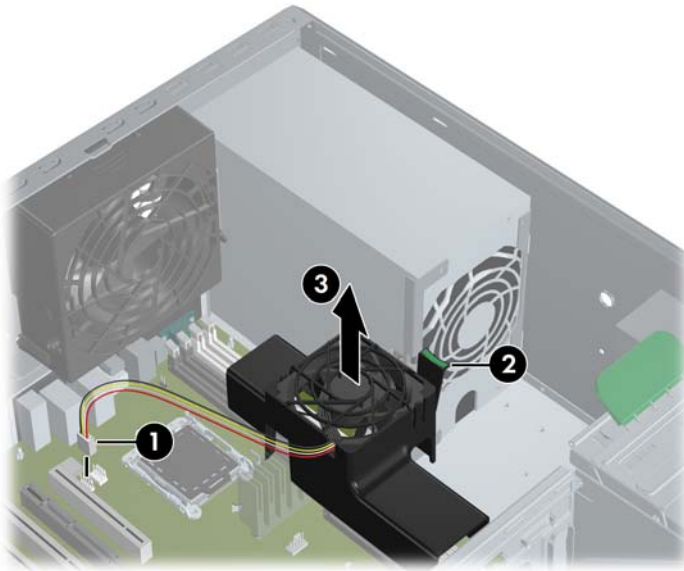

To replace the memory fan, reverse the previous steps. Ensure that the memory fan power cable is connected to the system board.

## Memory

### Memory module features

- Eight memory slots for DIMMs, four per CPU
- Accepts 512-MB, 1-GB , 2-GB, 4-GB, and 8-GB DIMMs
- 64-GB maximum configuration with 8-GB DIMMs
- Standard ECC PC2-5300 DIMMs
- No support for mirroring
- No spare DIMM support

### Memory module requirements

- Use only PC2-5300 ECC DIMMs. Certified and warranted HP memory is recommended.
- Match DIMM pairs by size and type.

## Removing memory module

1. Disconnect power from the system ([Pre-disassembly procedures on page 55](#)), and remove the access panel ([Access panel on page 63](#)). Place the workstation on its side with the system board facing up.
    - △ **CAUTION:** To ensure that memory modules are not damaged during removal or installation, power off the workstation and unplug the power cord from the AC power outlet. Wait until the LED on the back of the power supply turns off before removing memory. If you do not unplug the power cord while installing memory, your memory modules might be damaged and the system will not recognize the memory changes.
  2. Remove the memory fan. Press the tab in on the memory fan housing (**1**) and lift the unit out of the chassis (**2**).
-  **NOTE:** The system fan ([System fan on page 70](#)) must also be removed to access DIMMs in the rear slots.

**Figure 5-15** Removing memory fan

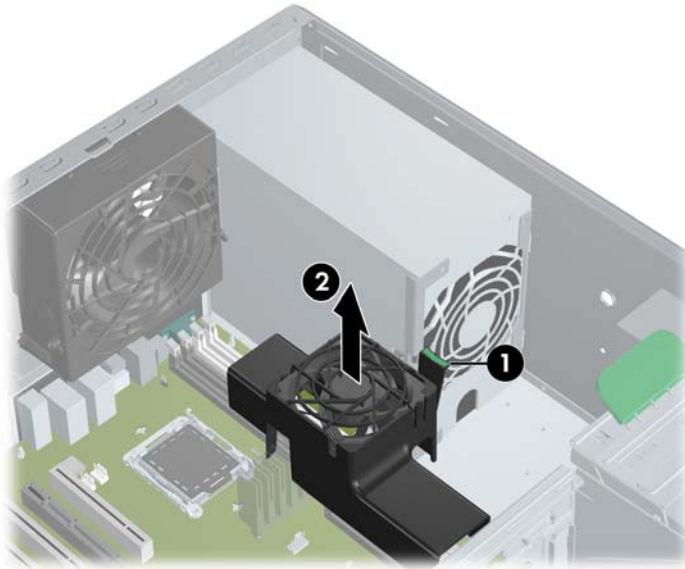

3. Gently push out on the socket levers (**1**).

4. Lift the DIMM straight up, and remove it from the unit (2).

**Figure 5-16** Removing DIMM

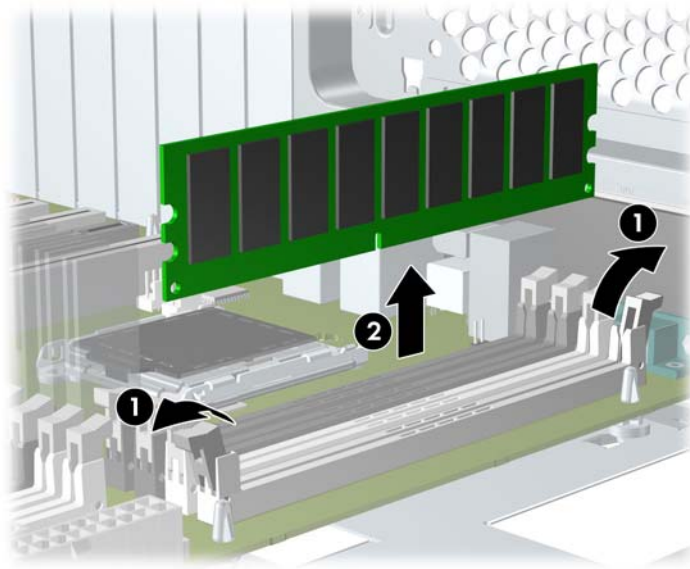

---

 **NOTE:** DIMMs and DIMM sockets are keyed for proper installation. Be sure these guides align when installing a DIMM.

---



## Installing a memory module

 **NOTE:** HP only ships DIMMs that are electrically and thermally compatible with this product. Because third-party DIMMs might not be electrically or thermally compatible, they are not supported by HP.

1. Disconnect power from the system ([Pre-disassembly procedures on page 55](#)) and remove the access panel ([Access panel on page 63](#)). Lay the workstation on its side with the system board facing up.
2. Depress the green tabs on the memory fan housing (1) and lift the unit out of the chassis (2).

**Figure 5-17** Removing the memory fan

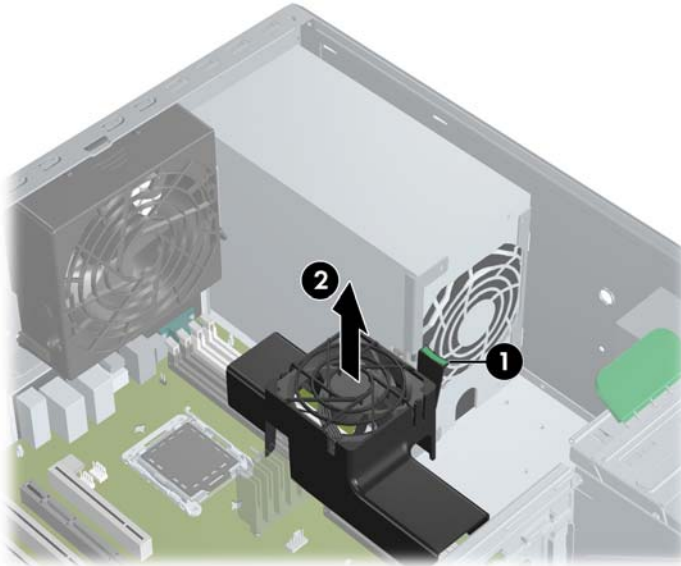

3. Gently push out on the socket levers.
4. Prepare to load memory modules in valid configurations:
  - DIMMs must be loaded in matched pairs.
  - If loading two DIMMs, install them in slots 1a/1b.
  - If loading four DIMMs, install them in slots 1a/1b and 2a/2b for a dual CPU system, or in 1a/1b and 3a/3b for a single CPU system.
  - If loading six DIMMs, install them in slots 1a/1b, 2a/2b, and 3a/3b.
  - If loading eight DIMMs, install them in all slots.
  - Load the memory module pairs in order of size, from largest to smallest.

**Figure 5-18** Identifying memory slots

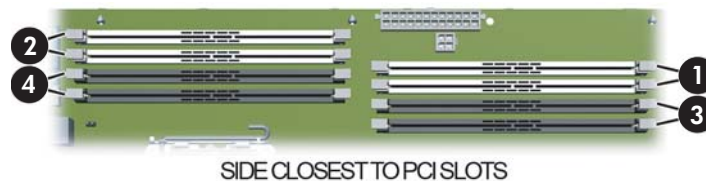

5. Lower the DIMM straight down, and be sure the socket levers secure the module into place.

---

 **NOTE:** DIMMs and DIMM sockets are keyed for proper installation. Be sure these guides align when installing a DIMM.

---

6. Lower the memory fan until it snaps into place.

 **NOTE:** Ensure that all cables are clear of the fan housing when lowering the memory fan.

---

The BIOS generates warnings/errors on invalid memory configurations.

- If BIOS cannot obtain a valid memory configuration, it will halt the system with a diagnostics 2006 code for memory error (five beeps and blinks).
- If memory node interleave is enabled but the memory installed on the two CPUs is not equal, BIOS will report a warning during POST (“215-Cannot Interleave Unequal Memory Nodes”). The system can still boot in this condition.

## PCI slots

Figure 5-19 Identifying PCI slots

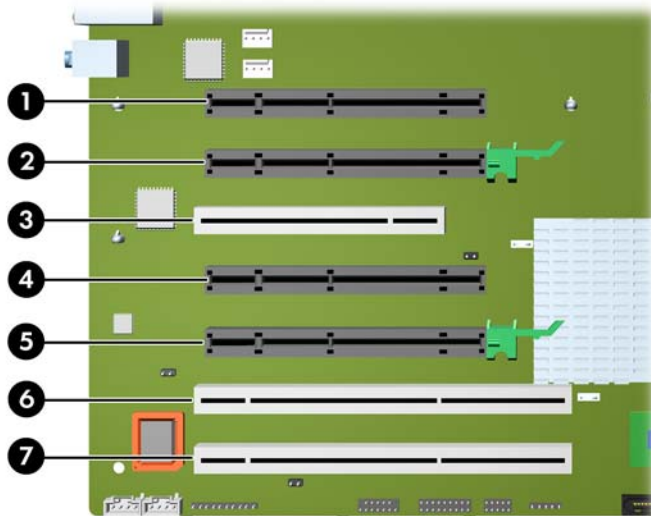

Table 5-4 PCI slots

Slot	Type	Ref
1	PCI Express x16 (x8)	J31
2	PCI Express x16 graphics	J41
3	PCI 32 bit, 33 MHz	J20
4	PCI Express x16 (x8)	J33
5	PCI Express x16 graphics	J32
6	PCI-X 100	J25
7	PCI-X 100/133	J26

## PCI retainer

For added protection, some cards have PCI retainers installed to prevent movement during shipping.

### Removing the PCI retainer

1. Disconnect power from the system ([Pre-disassembly procedures on page 55](#)), and remove the access panel ([Access panel on page 63](#)). Place the workstation on its side with the system board facing up.
2. For both short and tall cards, press in on the sides (1) of the retainer, and rotate it (2) out of the chassis.

**Figure 5-20** Removing the short or tall card PCI retainer

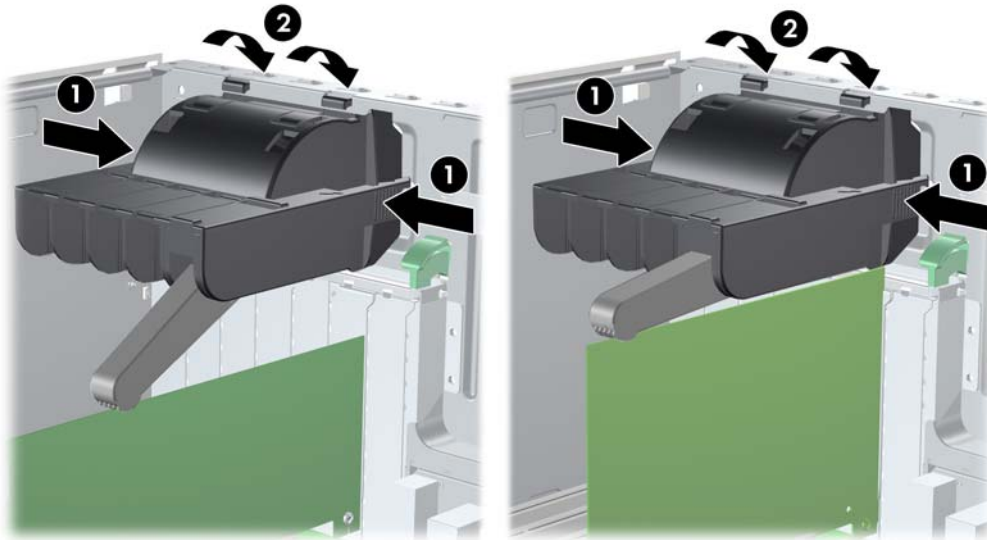

### Installing the PCI retainer

1. Disconnect power from the system ([Pre-disassembly procedures on page 55](#)), and remove the access panel ([Access panel on page 63](#)). Place the workstation on its side with the system board facing up.

2. For both short and tall PCI cards, attach the hooks of the PCI retainer (1) under the slots on the rear of the chassis, and then rotate the retainer down until the retainer arm (2) supports the card.

**Figure 5-21** Installing the short or tall card PCI retainer

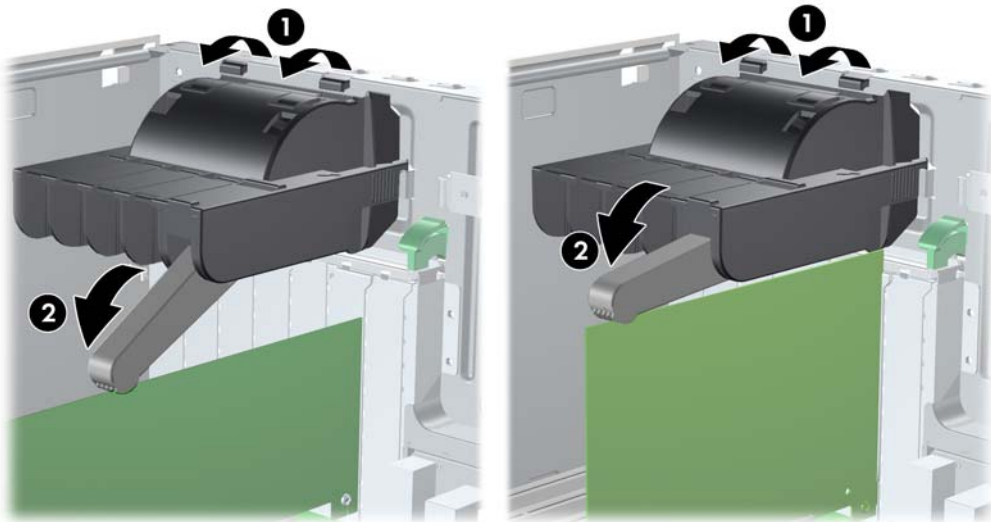

## PCI retention clamp

1. Disconnect power from the system ([Pre-disassembly procedures on page 55](#)), and remove the access panel ([Access panel on page 63](#)). Place the workstation on its side with the system board facing up.
2. Open the PCI retention clamp by pressing down on the two green clips at the ends of the clamp and rotating the clamp toward the back of the system.

**Figure 5-22** Opening the PCI retention clamp

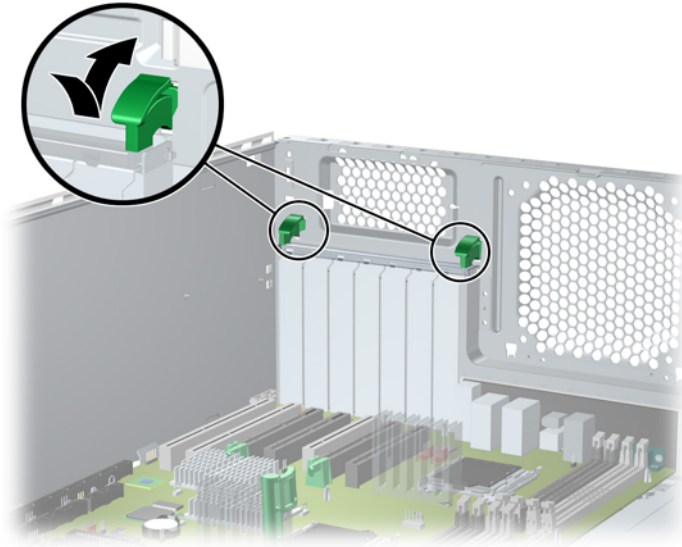

## PCI Express

PCI Express is a point-to-point architecture and uses a serial data transmission protocol. A single PCI Express lane consists of four wires and can transmit 250 MB/s in a single direction or 500 MB/s in both directions simultaneously. This bandwidth is not affected by what is happening on other PCI Express buses or legacy PCI/PCI-X buses (provided that total bandwidth can be handled by the CPU and the memory subsystem.) The transmission protocol is somewhat similar to that used for a LAN connection and contains error correction and detection, packet addressing, and other network features.

PCI Express improves system attributes. PCI Express enables a low-power, scalable, high-bandwidth communication path with a small number of connections (wires) compared to traditional parallel interfaces (for example, PCI).

The PCI Express I/O slots can support other PCI Express cards with lesser bus bandwidth than what is physically defined for the slot. Use the following table to determine compatibility.

For example, a PCI Express x8 card does not work in a PCI Express x1 slot, but a PCI Express x1 card works in a PCI Express x8 slot.

**Table 5-5 PCI Express compatibility matrix for xw9400**

	<b>Slot 1*</b> <b>x16 mechanical</b> <b>x8 electrical</b>	<b>Slot 2</b> <b>x16 mechanical</b> <b>x16 electrical</b>	<b>Slot 4</b> <b>x16 mechanical</b> <b>x8 electrical</b>	<b>Slot 5</b> <b>x16 mechanical</b> <b>x16 electrical</b>
PCI Express x1 Card	Yes	Yes	Yes	Yes
PCI Express x4 Card	Yes	Yes	Yes	Yes
PCI Express x8 Card	Yes	Yes	Yes	Yes
PCI Express x16 Card	Yes	Yes	Yes	Yes

\* Slot 1 is for short cards only.

## Removing PCI or PCI Express cards

1. Disconnect power from the system ([Pre-disassembly procedures on page 55](#)), and remove the access panel ([Access panel on page 63](#)). Place the workstation on its side with the system board facing up. Remove the PCI retainer ([PCI retainer on page 78](#)) if present.
2. Open the PCI retention clamp by pressing down on the two green clips at the ends of the clamp (1) and rotating the clamp toward the back of the system.
3. Lift the PCI card out of the chassis (2). If removing a PCI Express high-end graphics card, remove the auxiliary power supply cable (not illustrated) if required, and move the lever to release the card (3) and lift it out of the chassis. Store the card in an anti-static bag.

**Figure 5-23** Removing PCI or PCIe card

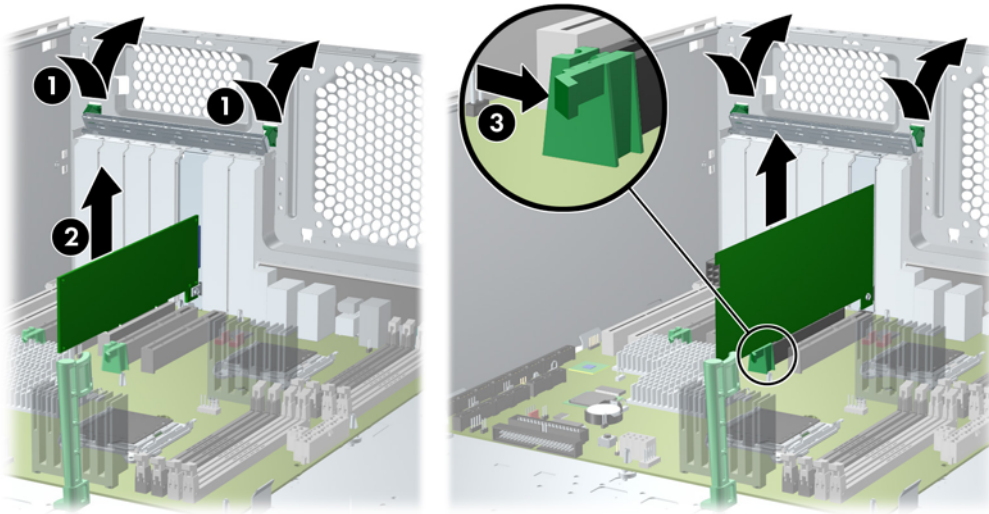

4. For cards with extenders, release the PCI Express slot latch (1) and lift up slightly. Press the clip on the card guide (2) and lift the card out of the chassis (3).

**Figure 5-24** Removing PCIe card with extender

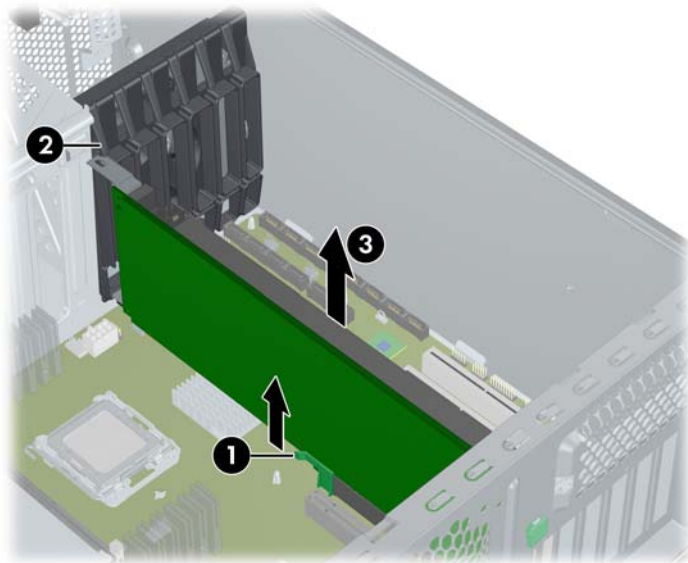



## PCI or PCI Express installation

1. Disconnect power from the system ([Pre-disassembly procedures on page 55](#)), and remove the access panel ([Access panel on page 63](#)). Place the workstation on its side with the system board facing up, and remove the PCI retainer ([PCI retention clamp on page 80](#)).
2. Open the PCI retention clamp by pressing down on the two green clips (1) at the ends of the clamp and rotating the clamp toward the back of the system.
3. Remove the PCI slot cover (2).
4. Lower the PCI (3) or PCI Express (3) card into the chassis. Verify that the keyed components of the card align with the socket.

If installing a card with an auxiliary power connector, plug in the power supply cable or adapter cable supplied with the card (4).

5. Ensure that all cards are properly seated, and close the PCI retention clamp.

**Figure 5-25** Installing PCI or PCIe card

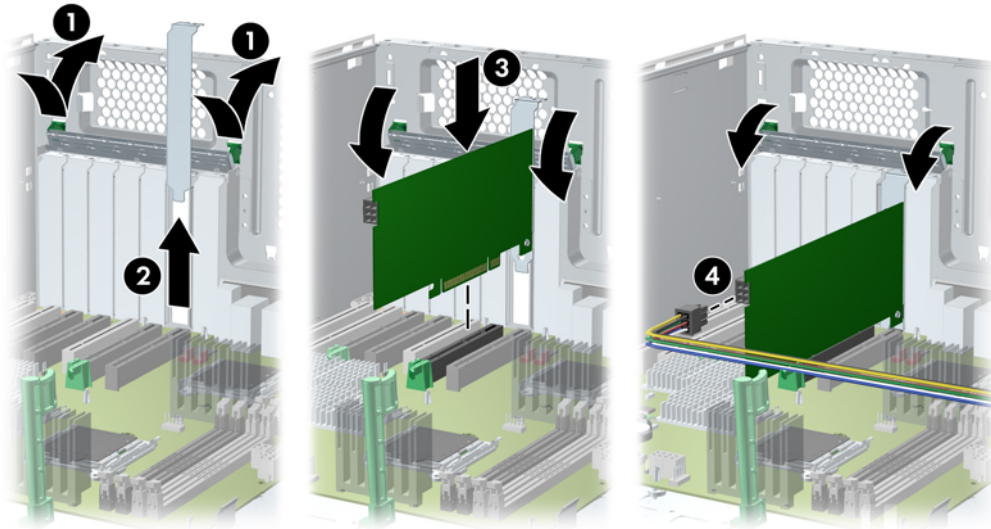

## Front fan removal

To remove the front fan:

1. Disconnect power from the system ([Pre-disassembly procedures on page 55](#)), and remove the access panel ([Access panel on page 63](#)). Place the workstation on its side with the system board facing up.
2. Disconnect optical and floppy drive cables from the system board. Remove full length PCI cards.
3. Disconnect the front fan cable from the connector on the system board.
4. Release the two card guide latches (1), pivot the card guide toward the system board (2), and lift it out of the chassis (3).

**Figure 5-26** Removing card guide

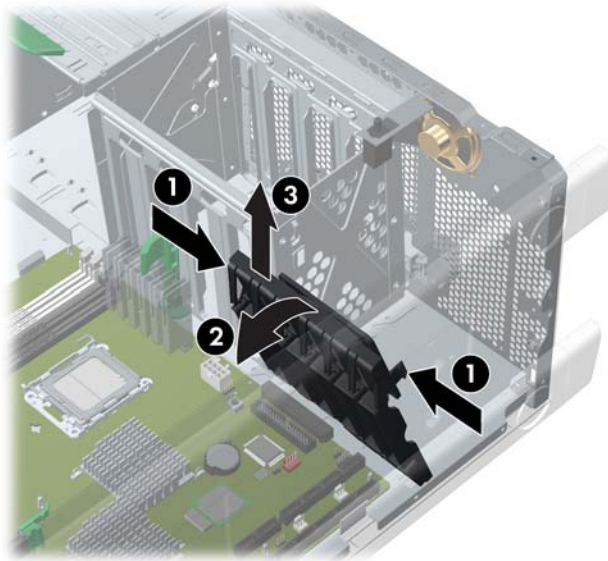

5. Remove the fan from the card guide by releasing the two latches and applying outward pressure on the card guide while lifting the fan away.

**Figure 5-27** Removing fan from card guide

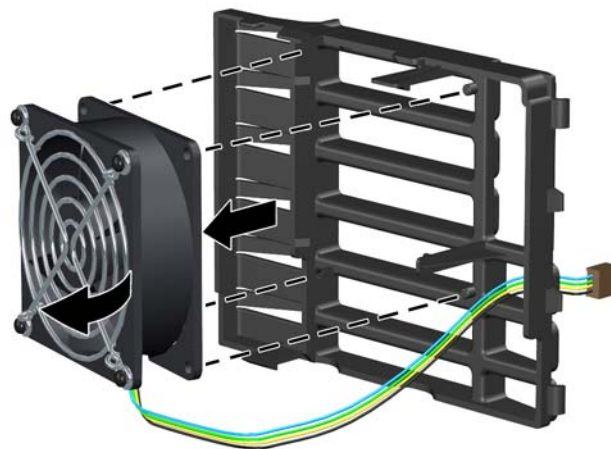

To install the front fan:

1. Place the fan in the card guide with the fan label facing into the card guide, and the fan protector screen facing outward.

 **NOTE:** Ensure that the fan blows toward the rear of the chassis.

2. Thread the front fan cable through the slot in the card guide.
3. Set the front fan in the card guide and snap the fan into place.

**Figure 5-28** Installing the fan in card guide

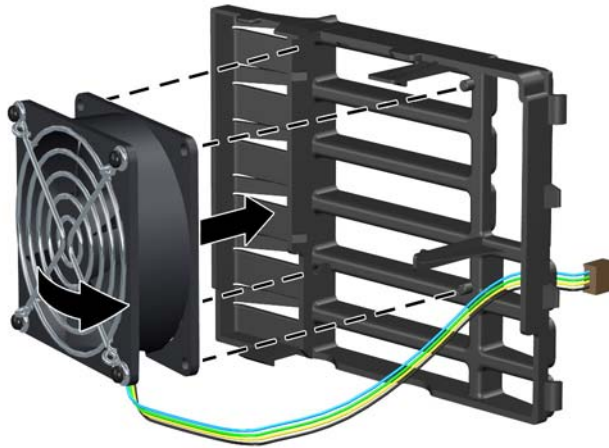

4. Lower the card guide with installed fan into the chassis. Place the card guide tabs into the chassis slots and snap the card guide into place.
5. Plug the front fan cable into its connector on the system board.

## Front fan jumper cable installation

This procedure describes how to install a front fan jumper cable in an HP xw9400 Workstation when a 4 GB or greater DIMM is used in the workstation. The additional jumper cable provides for quieter fan operation.

1. Disconnect the front system fan cable from the system board.

**Figure 5-29** Disconnect front system fan cable from system board

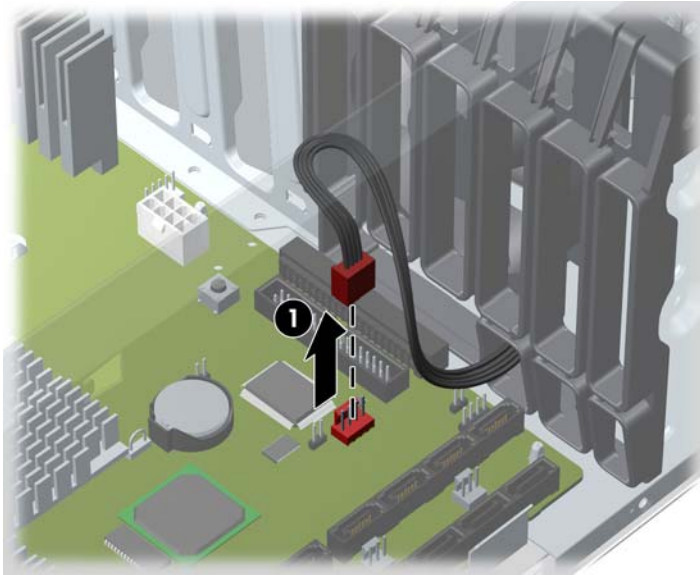

2. Connect the system fan jumper cable to the front system fan cable.

**Figure 5-30** Connect system fan jumper cable to front system fan cable

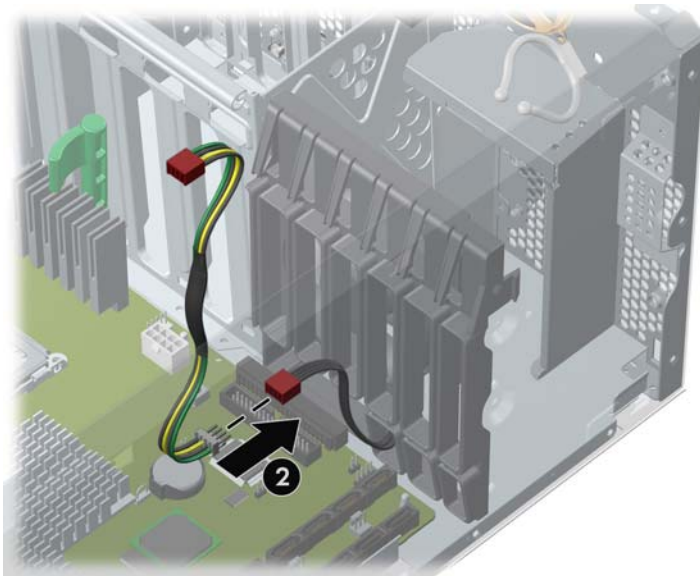

3. Place the excess cable in the empty space under the hard drive cage.

**Figure 5-31** Place excess cable in chassis

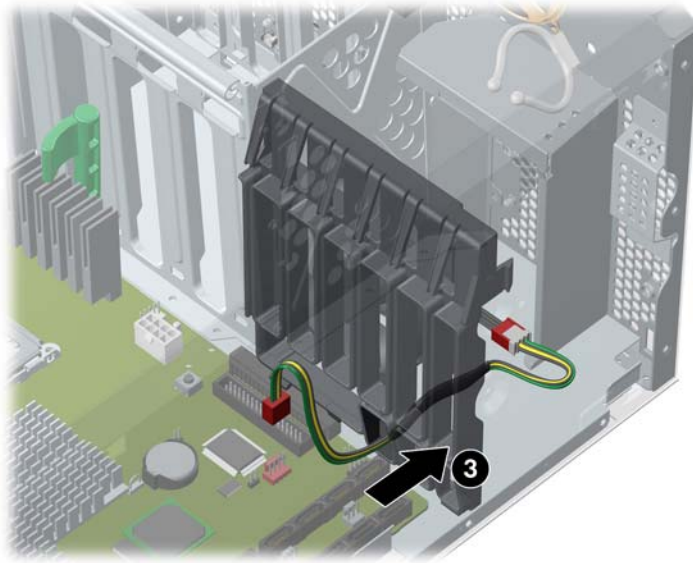

4. Connect the system fan jumper cable to the front fan cable connector on the system board. Use the system board connector to which the original front fan cable connected.

**Figure 5-32** Connect system fan jumper cable to system board

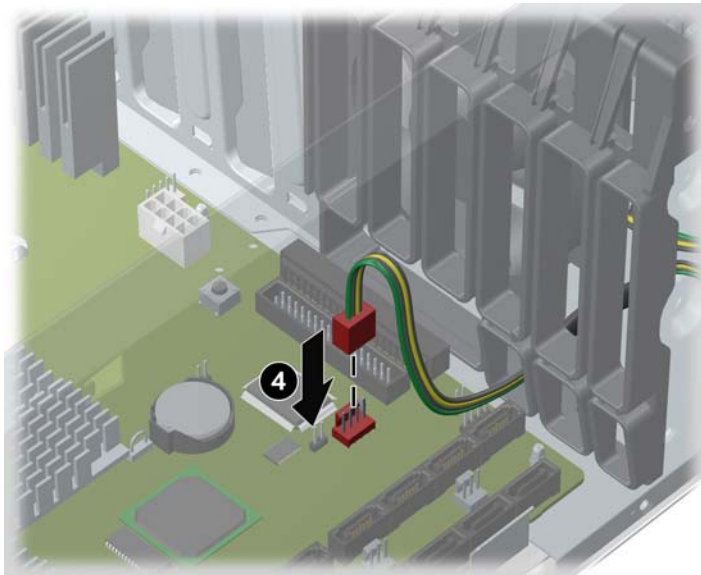

## Battery

- △ **CAUTION:** Before removing the battery, be sure your CMOS settings are backed up because all CMOS settings are lost when the battery is removed. To back up the CMOS settings, use Computer Setup and run the Save to Diskette option from the File menu.

To remove the battery:

1. Disconnect power from the system ([Pre-disassembly procedures on page 55](#)), and remove the access panel ([Access panel on page 63](#)). Place the workstation on its side with the system board facing up.
2. On the system board, press on the release tab of the battery holder.
3. Rotate the battery enough to get beyond the latch, and lift it straight up.

**Figure 5-33** Removing the battery

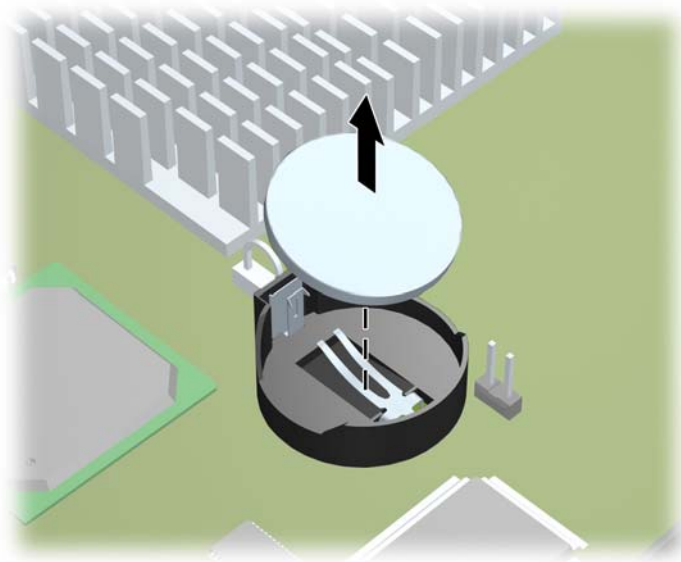

To install the battery, slide the battery into the holder until it snaps into place.



## Power connections to drives

For help in identifying power cables, refer to the following figure and table. Route or tie cables so that they cannot interfere with the CPU heatsink fans.

**Figure 5-34** Identifying correct power connections

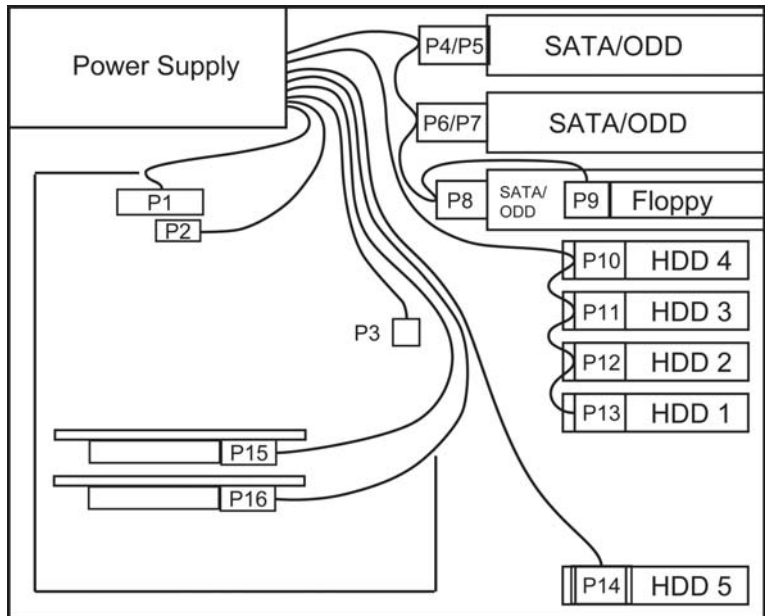

**Table 5-6** Power connector descriptions

Connector	Description
P1	24-pin main power connector
P2	4-pin memory power connector
P3	8-pin processor power connector
P4–P8	SATA and IDE ODD/ accessory power connectors
P9	Diskette connector
P10–P14	HDD connector
P15	PCIe connector
P16	PCIe connector

## Optical drive

Your workstation might have a SATA or an IDE optical drive. To remove the optical drive:

1. Disconnect power from the system ([Pre-disassembly procedures on page 55](#)) and remove the access panel ([Access panel on page 63](#)).
2. Disconnect the audio (1), data (2), and power (3) cables from the drive. The connector colors might be different than illustrated.

 **NOTE:** The audio cable is only required for Linux-based systems.

**Figure 5-35** Disconnecting IDE (left) or SATA (right) cable from optical drive

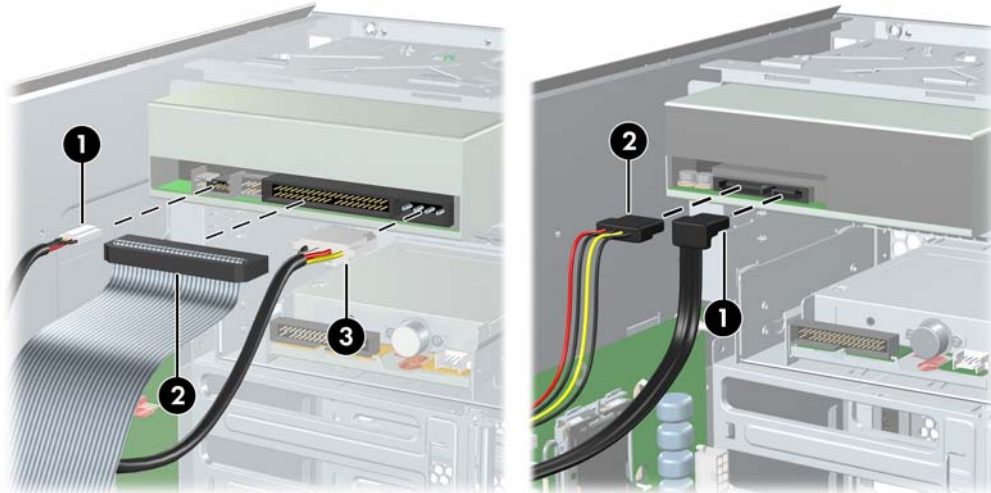

3. Lift the green drivelock release lever, and gently slide the drive out of the chassis.

**Figure 5-36** Removing optical drive from chassis





To replace an optical drive:

1. Lift the green drivelock release lever while sliding the optical drive into the bay. When the optical drive is partially inserted, release the drivelock release lever, and slide the drive completely into the bay until the drive is secured.

△ **CAUTION:** Ensure that the optical drive is secure. Failure to do so can cause damage to the drive when moving the workstation.

2. Connect the power, data , and audio (if required) cables to the drive and workstation.

📝 **NOTE:** The audio cable is only required for Linux-based systems.

3. If you are installing more than one optical drive, route the cable as in the following image.

**Figure 5-37** Connecting IDE (left) or SATA (right) optical drive cable to system board

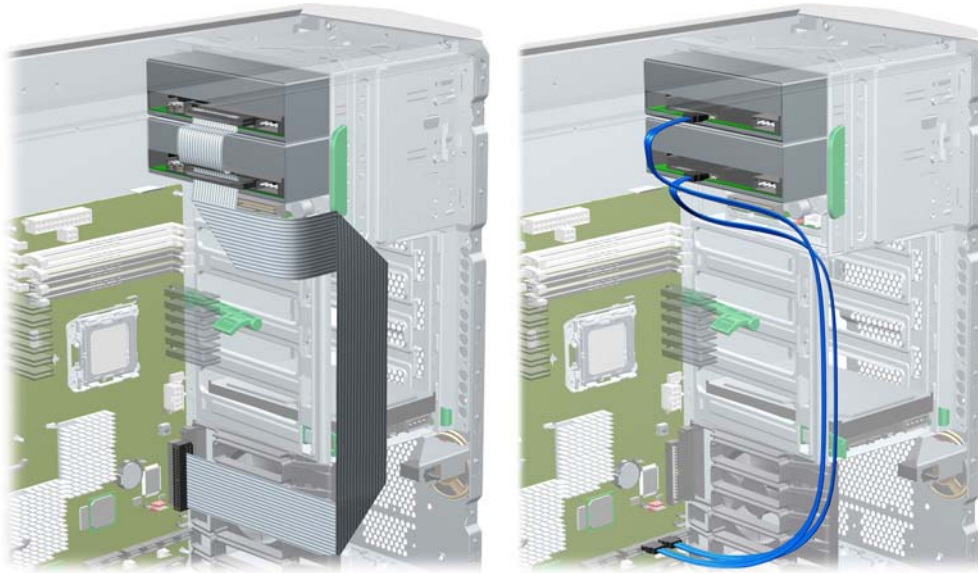

## Replacing the SATA optical drive data cable

If your workstation has a SATA optical drive, replace the cable as follows:

1. Disconnect power from the system ([Pre-disassembly procedures on page 55](#)), and remove the access panel ([Access panel on page 63](#)). Place the workstation on its side with the system board facing up.
2. Disconnect the SATA data cable from the system board and from the optical drive.
3. Replace the cable. Attach it to the optical drive and its system board connector as shown.

## Notice for Blu-ray optical drives

If you installed a Blu-ray optical drive, note the following:

### Blu-ray movie playback

As Blu-ray is a new format containing new technologies, certain disc, digital connection, compatibility and/or performance issues may arise, and do not constitute defects in the product. Flawless playback on all systems is not guaranteed. In order for some Blu-ray titles to play, they may require a DVI or HDMI digital connection and your display may require HDCP support. HD-DVD movies cannot be played on this workstation.

### Blu-ray movie playback compatibility and update

Playing back Blu-ray HDCP (High-bandwidth Digital Content Protection) content such as commercially distributed Blu-ray HD movies requires a fully HDCP compliant path on your computer. The HDCP technology checks compliance of each component in the path from the content on the Blu-ray disc all the way to the display monitor, including but not limited to graphic cards and monitor adapters.

The HP **Z400**, **Z600** and **Z800** Workstations have been designed with this in mind; nearly all configurations with currently available HP Professional Displays are compliant. Older HP xw4600 and xw9400 Workstation configurations may not have fully compliant paths based on the installed graphics card and display monitor; HP recommends confirming separately that you have a fully compliant system if commercial content playback is a requirement for your use. HDCP compatibility of your graphics card and monitor can be determined by checking the *QuickSpecs* at <http://www.hp.com/go/productbulletin>.

For the best HDCP performance, HP recommends that you install the latest updates:

1. Blu-ray player firmware
2. Playback application patches
3. Graphics firmware and drivers

Updates are located on the support web site for your specific product at <http://www.hp.com/support/workstations>.

## Diskette drive (optional)

To remove a diskette drive:

1. Disconnect power from the system ([Pre-disassembly procedures on page 55](#)). Remove the access panel ([Access panel on page 63](#)) and the front bezel ([Front bezel on page 64](#)).
2. Disconnect the data and power cables from the back of the diskette drive.

**Figure 5-38** Disconnecting cables from the diskette drive



3. While lifting the green drivelock release tab, slide the drive forward out of the chassis.

**Figure 5-39** Removing the diskette drive from the chassis



4. Remove the diskette drive from its bracket by removing the two M3 screws in the rear-most holes and pulling the diskette drive from the bracket.

**Figure 5-40** Removing the diskette drive from the bracket

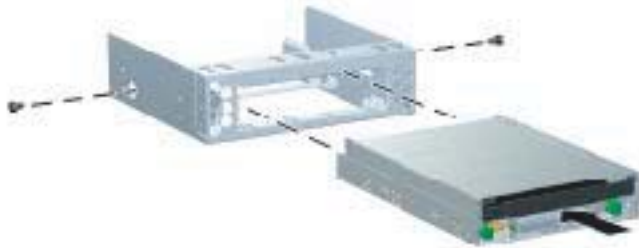

To replace a diskette drive:

1. Slide the diskette drive into the bracket, and secure it with two M3 screws.
2. While lifting the green drivelock release tab, slide the drive into the chassis.
3. Route the diskette drive data cable between the system board and the hard drive cage. Your cable might look different than the one shown. Connect the data and power cables to the diskette drive. Ensure that the power cable is connected to the system board.

**Figure 5-41** Routing the diskette drive cable to the system board

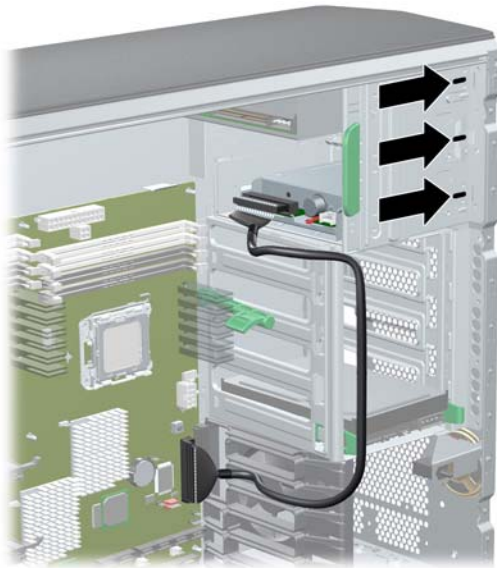

4. Connect the cables to the back of the diskette drive.

## Hard drive

### Replacing a hard drive

For more information on SATA hard drives and the SATA RAID configuration, see [Appendix B—SATA devices on page 172](#).

### Removing a hard drive

1. Disconnect power from the system ([Pre-disassembly procedures on page 55](#)), and remove the access panel ([Access panel on page 63](#)).
2. Disconnect the cables from the hard drive.
3. Push in on the green drivelock release tabs, and pull the hard drive out of the chassis.

**Figure 5-42** Removing the hard drive

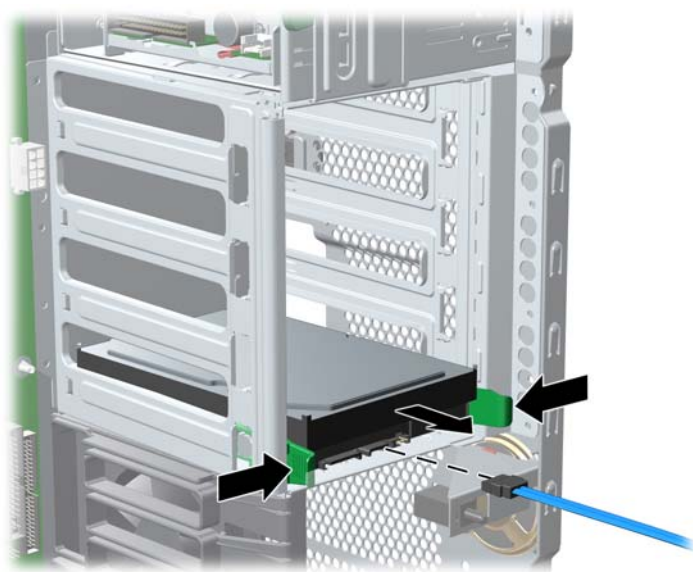

## Installing a hard drive

1. Select a drive bay in which to install the drive. If installing more than one hard drive, use the hard drive order shown in the following image.

**Figure 5-43** Identifying hard drive installation order



2. Squeeze the green tabs, and slide the rails out of the empty bay.
3. Attach the rails to the hard drive. Align the pins on the rails with the hard drive holes, and snap the rails into place.

**Figure 5-44** Attaching rails to the hard drive

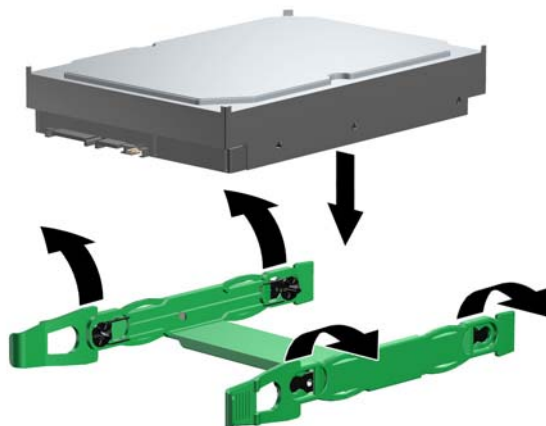

4. Push the drive into the selected bay until it snaps into place.



5. Attach a data cable from a SATA connector on the system board to the hard drive, and attach a power cable to the drive.

**Figure 5-45** Replacing the SATA hard drive

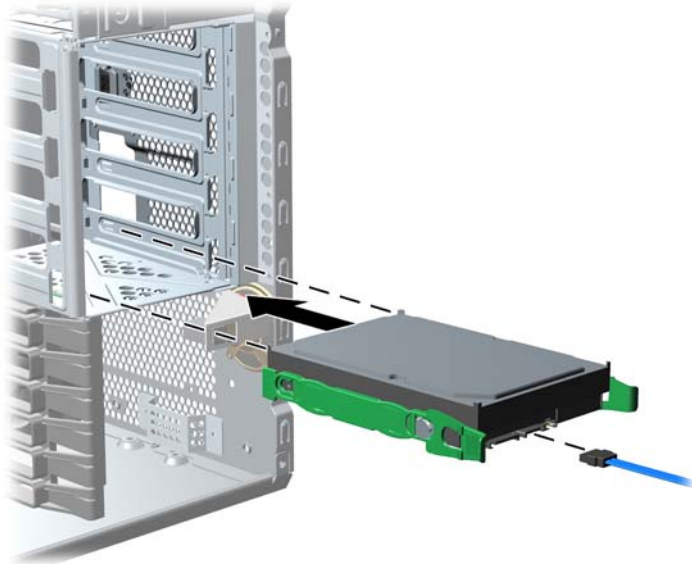

6. For a SAS hard drive, attach a SAS/SATA adapter to the connector on the hard drive. Attach a data cable from a SAS connector on the system board to the hard drive, and attach a power cable to the drive.

**Figure 5-46** Installing the SAS/SATA adapter (left) and cable (right)



## Installing a hard drive in the fifth hard drive bay

To install a SAS or SATA hard drive into fifth HDD bay:

1. Place the workstation on its side, and remove the three drive screws that are located on the bottom of the chassis.

**Figure 5-47** Installing screws for the hard drive in the fifth hard drive bay

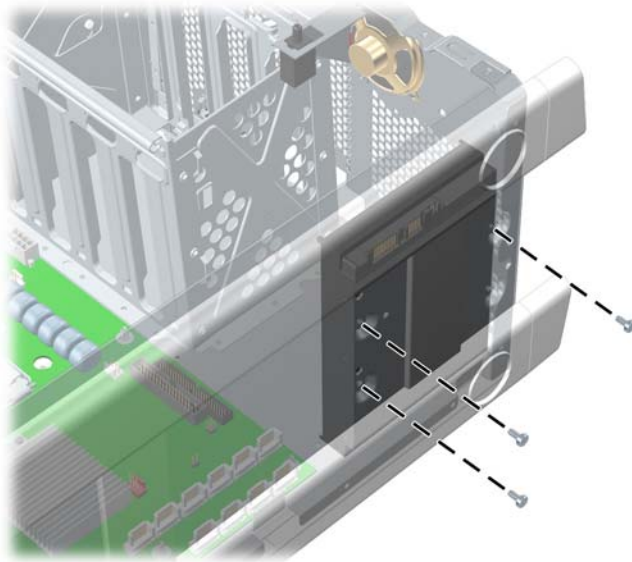

2. Insert the drive into bay five and align the holes in the bottom of the hard drive with the screw holes at the base of the chassis.
3. Insert the screws through the base, and tighten them to secure the hard drive to the chassis.
4. Attach a data cable from a SATA connector on the system board to the hard drive, and attach the fifth drive power cable to the drive. It is attached to a clip in front of the power supply.

**Figure 5-48** Attaching the data cable for the SATA hard drive in the fifth hard drive bay

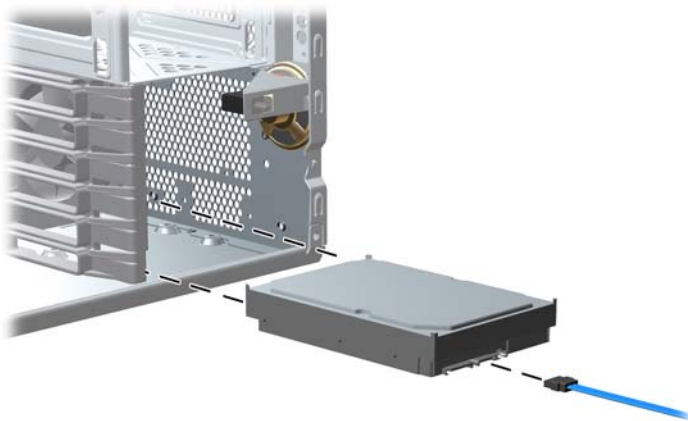

5. For a SAS hard drive, attach a SAS/SATA adapter to the connector on the hard drive. Attach a data cable from a SAS connector on the system board to the hard drive, and attach a power cable to the drive.



## Liquid cooling unit

The following section describes how to remove a processor liquid cooling unit.

### Removing the liquid cooling unit

The following steps describe removal of a liquid cooling unit.

1. Disconnect power from the system ([Pre-disassembly procedures on page 55](#)), and remove the access panel ([Access panel on page 63](#)). Place the workstation on its side with the system board facing up.
2. Loosen the two liquid cooling unit/radiator mounting screws **(1)** from the liquid cooling unit. Alternately and evenly loosen the two CPU 0 mounting screws **(2)**.

**Figure 5-49** Loosen radiator and CPU mounting screws

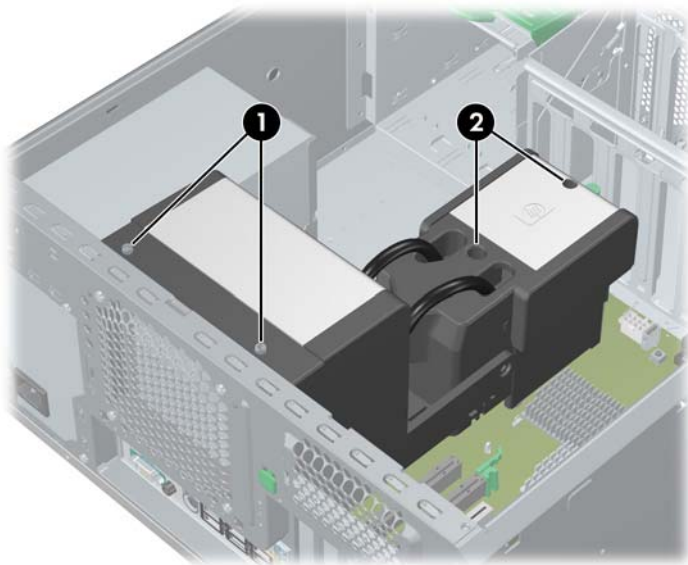

3. Raise the radiator to its upright position.

**Figure 5-50** Raise the radiator

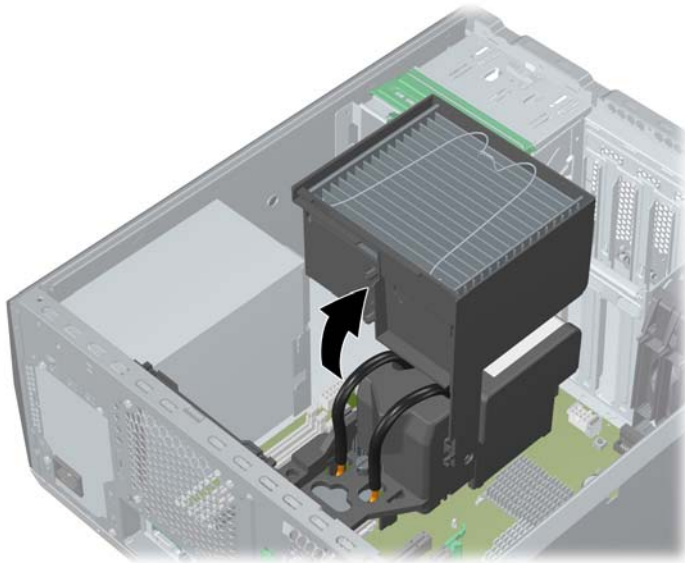

4. Disconnect the memory fan (1), radiator fan (2), and voltage regulator fan (3) cables from the system board. Pull the memory fan cable clear of the liquid cooling unit.

**Figure 5-51** Disconnect memory, radiator, and voltage regulator fan cables

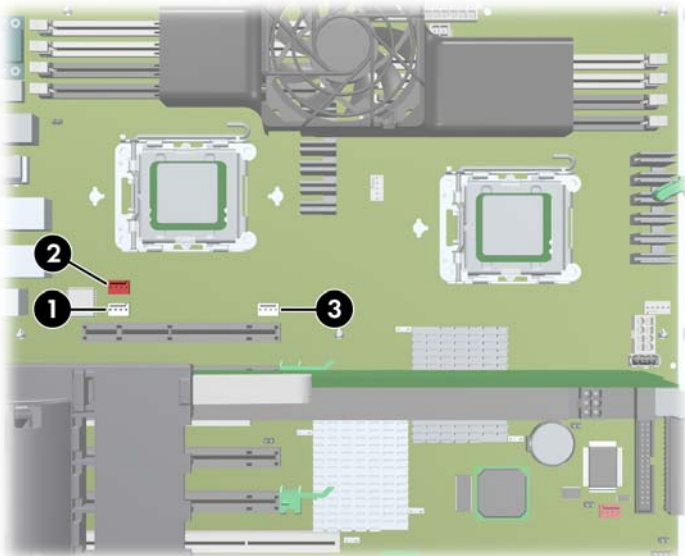

5. Alternately and evenly loosen the two liquid cooling unit/CPU 1 mounting screws from the liquid cooling unit.

**Figure 5-52** Loosen liquid cooling unit/CPU 1 mounting screws

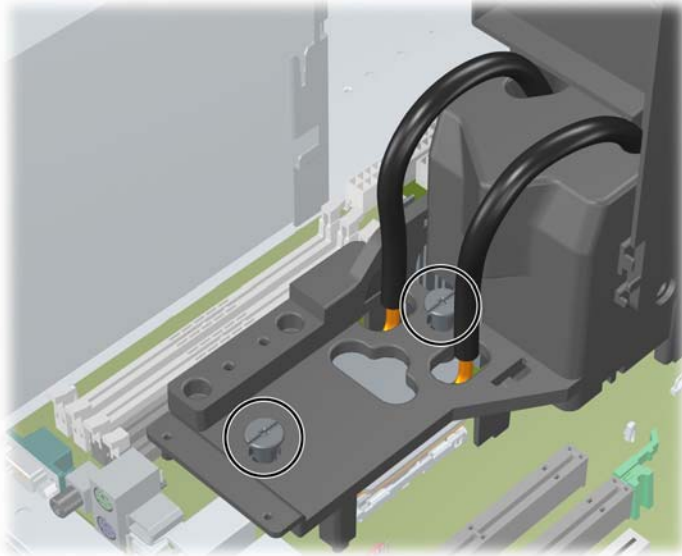

6. Lower the fan/radiator to its closed position.
7. For convenience, disconnect the PSU (1) cable from the system board. Disconnect the liquid cooling unit pump cable (2) from the system board.

**Figure 5-53** Disconnect pump cable

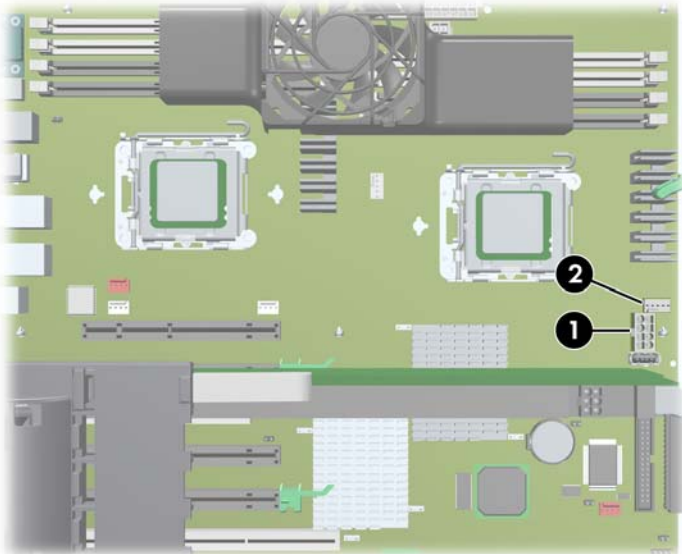

8. Press the green tab in on the memory fan housing (1) and lift the unit from the system board (2). Carefully pull the memory fan cable from the liquid cooling unit.

**Figure 5-54** Removing the memory fan

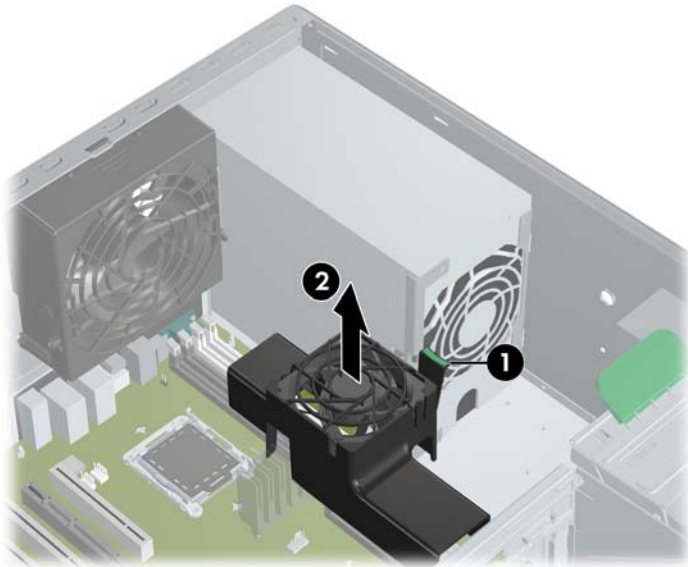

9. Raise the liquid cooling unit fan/radiator to its upright position and remove the unit from the workstation.

△ **CAUTION:** Be careful not touch the voltage regulator heatsink or the thermal compound on the processor.

10. If desired, loosen the liquid cooling unit chassis bracket screws and remove the bracket from the chassis. (This is necessary if the system board is to be removed.)

**Figure 5-55** Remove liquid cooling unit chassis bracket

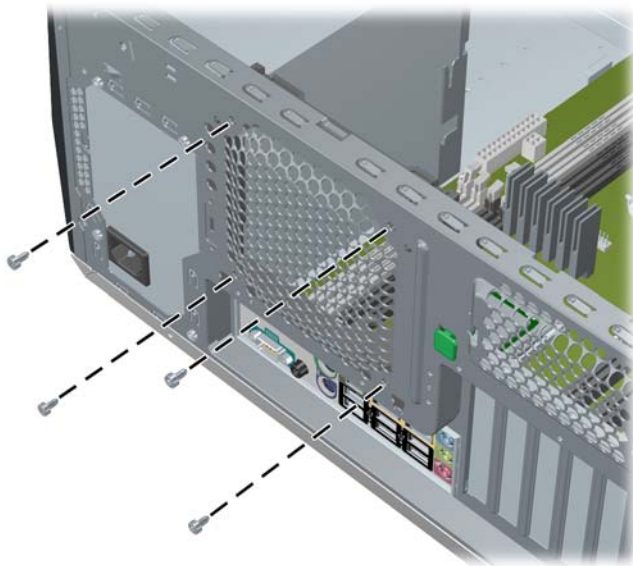

## Installing a liquid cooling unit

The following steps describe installation of a liquid cooling unit.

1. Disconnect power from the system ([Pre-disassembly procedures on page 55](#)), and remove the access panel ([Access panel on page 63](#)). Place the workstation on its side with the system board facing up.
2. Install the liquid cooling unit rear chassis bracket if it is not already installed.

**Figure 5-56** Install rear chassis bracket

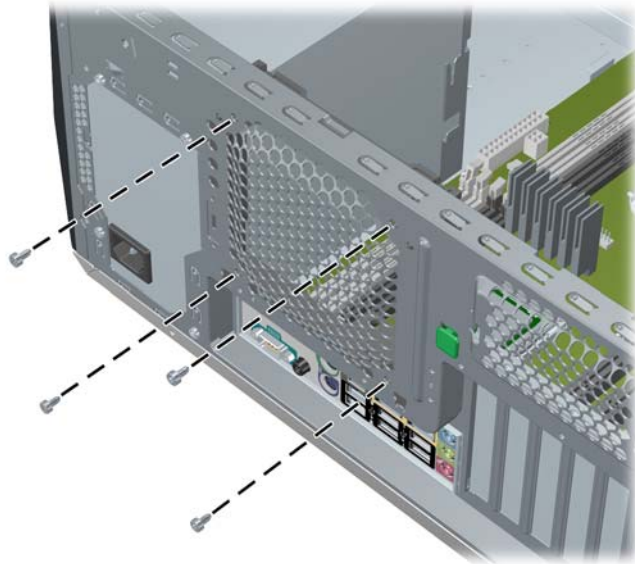

3. For a new installation, remove the plastic protectors covering the thermal interface material on the liquid cooling unit.

**Figure 5-57** Remove plastic protectors

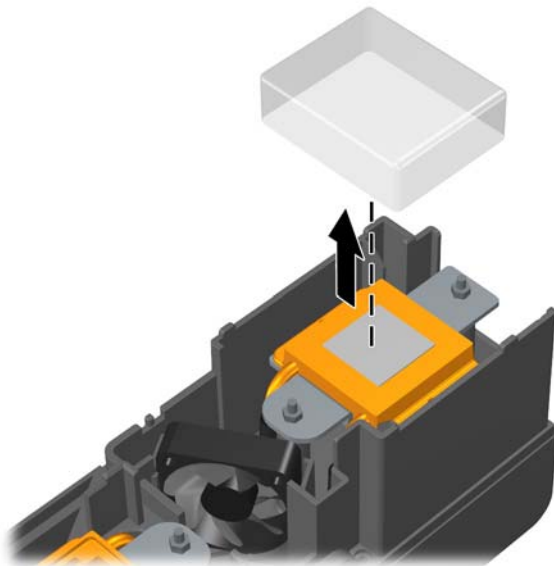

4. For a reused liquid cooling unit, clean the old thermal interface material from the processor and from the reused liquid cooling unit cold plates. Reapply new thermal interface material to the processors and to the reused liquid cooling unit.

 **NOTE:** Do not remove the interface material from a new liquid cooling unit.

5. Ensure all cables are clear of the installation area in the chassis. For convenience, disconnect P15 and/or P16 power cables from the graphics cards (if applicable), and disconnect the P3 power connector from the system board.
6. Place the liquid cooling unit fan/radiator in its upright position. Align the liquid cooling unit rear guide pins to the notches in the rear cover guide while slowly lowering the liquid cooling unit into the chassis.

 **WARNING!** Be careful not to put your fingers in the liquid cooling unit hinge arm.

 **CAUTION:** Be careful not to touch the voltage regulator heat sink or other nearby components. Ensure that the liquid cooling unit mounts to not touch the processor socket or other metal parts.

**Figure 5-58** Align guide pins to guide holes

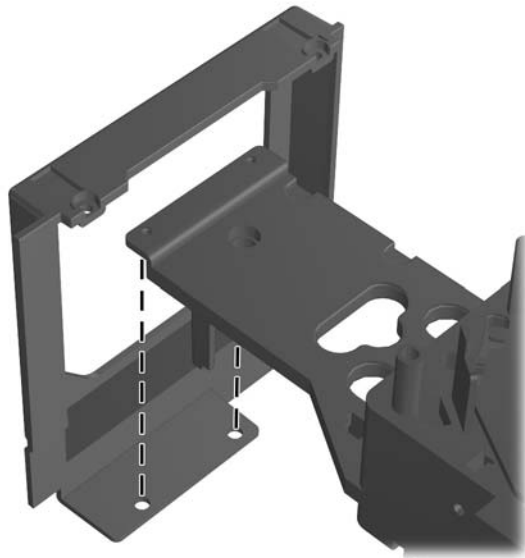

**Figure 5-59** Install liquid cooling unit in chassis

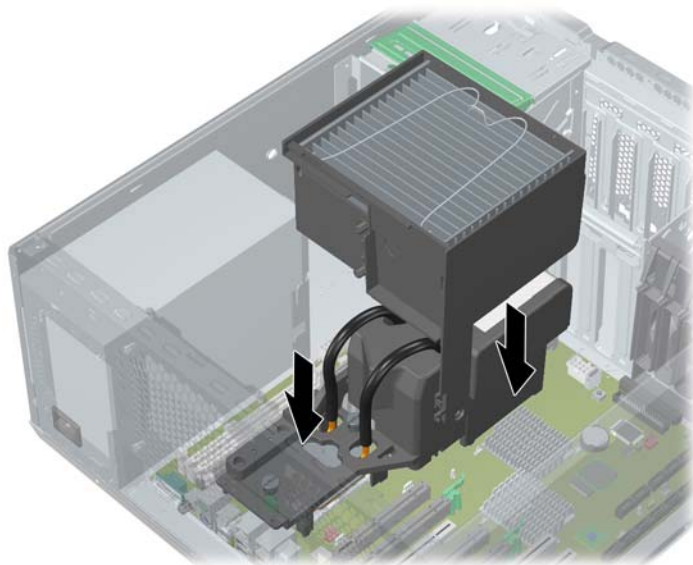



7. Lower the liquid cooling unit fan/radiator.
8. Install the workstation memory fan. Lower the memory fan assembly into the workstation chassis and snap it into place.

**Figure 5-60** Removing the memory fan

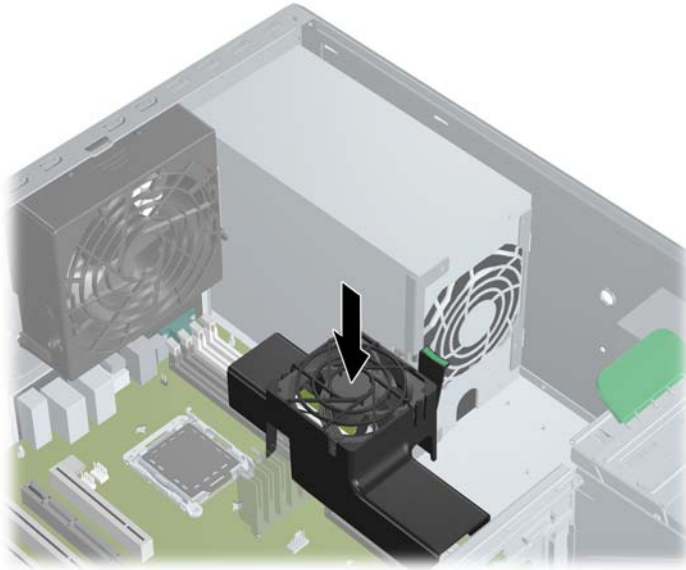

9. Guide the memory fan cable through the liquid cooling unit radiator tubing as shown in the following illustration.

**Figure 5-61** Position memory fan cable

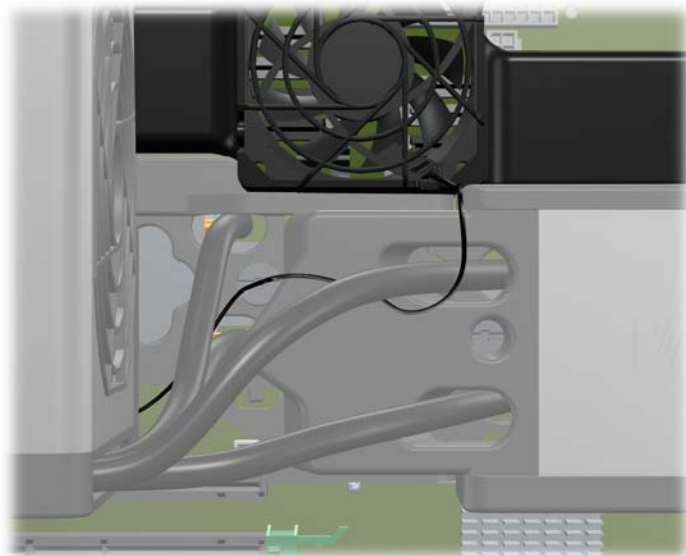

10. Raise the radiator fan to its upright position.

11. Connect the memory fan cable to the system board.

**Figure 5-62** Connect memory fan cable

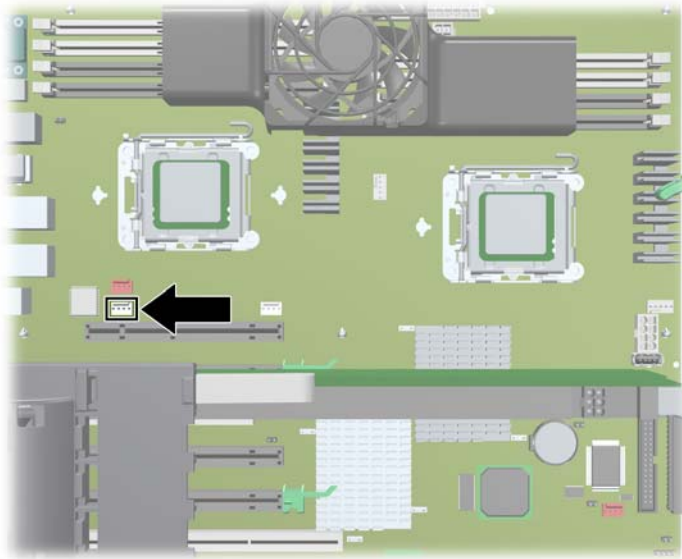

12. Connect the cables for the radiator fan (1) and voltage regulator fan (2) to the system board. For convenience, you may remove any nearby PC card from its slot while you connect cables.

△ **CAUTION:** Ensure that no cables interfere with the liquid cooling unit's system board mounts or with other components on the system board.

**Figure 5-63** Connect radiator fan and voltage regulator fan cables to system board

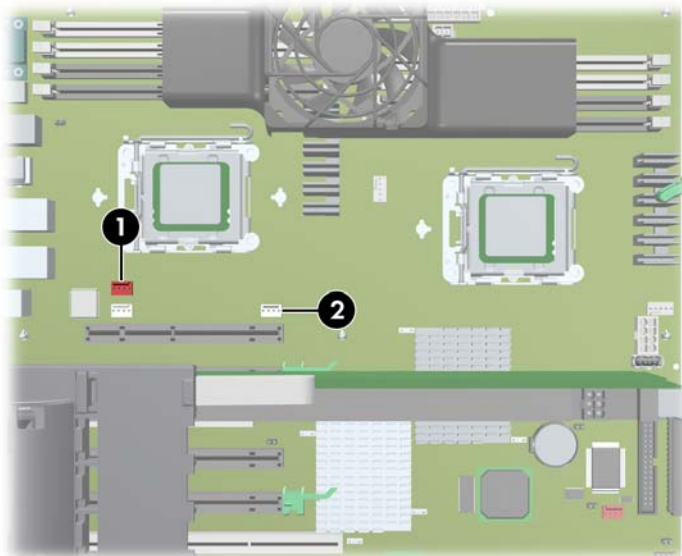



13. Alternately and evenly tighten the liquid cooling unit/CPU 1 mounting screws to a torque of 6 in./lbs.

**Figure 5-64** Tighten liquid cooling unit/CPU 1 mounting screws

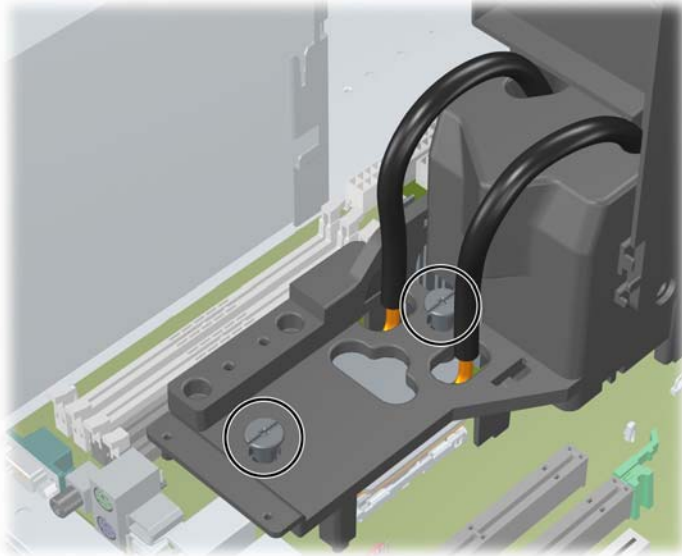

14. Lower the radiator to its closing position.
15. Alternately and evenly tighten the liquid cooling unit/CPU 0 mounting screws to a torque of 6 in./lbs.

**Figure 5-65** Tighten liquid cooling unit/CPU 0 mounting screws

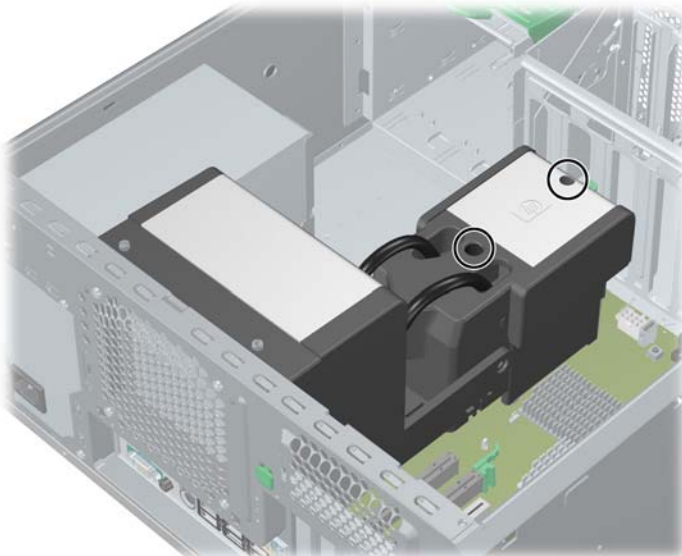

16. Tighten the radiator mounting screws.

**Figure 5-66** Position radiator and tighten mounting screws

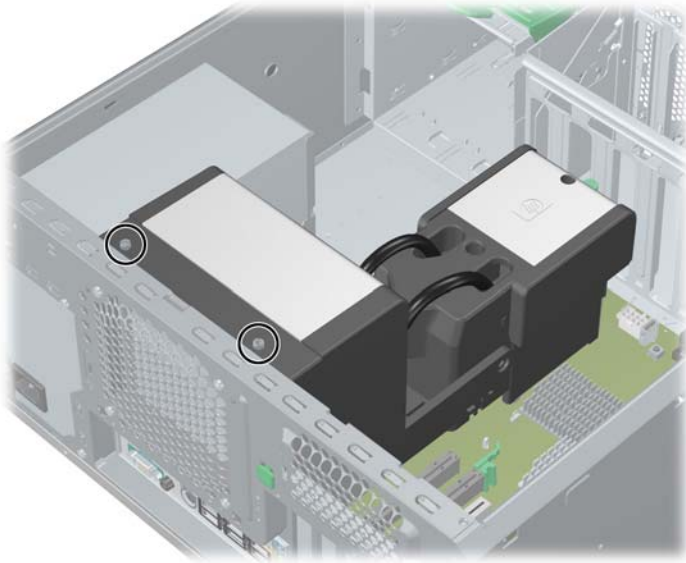

17. Connect the liquid cooling unit pump cable to the system board.

**Figure 5-67** Connect pump cable to system board

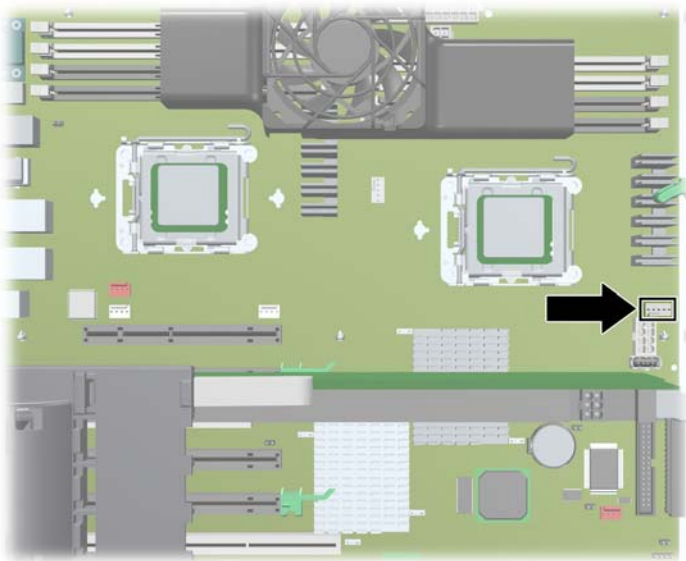

18. If appropriate, reconnect power cable P3 to the system board.

**Figure 5-68** Reconnect P3 to system board

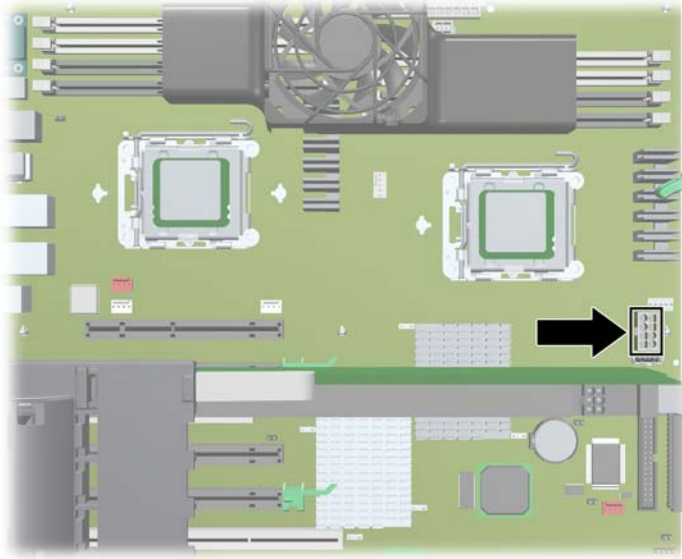

19. If appropriate, reconnect power cables P15 and/or P16 to the graphics cards.

## Replacing the liquid cooling unit VRD fan

This section explains how to replace the VRD fan in the liquid cooling unit.

### Removing the VRD fan

To remove the VRD fan:

1. Remove the VRD cable from the cable channel.

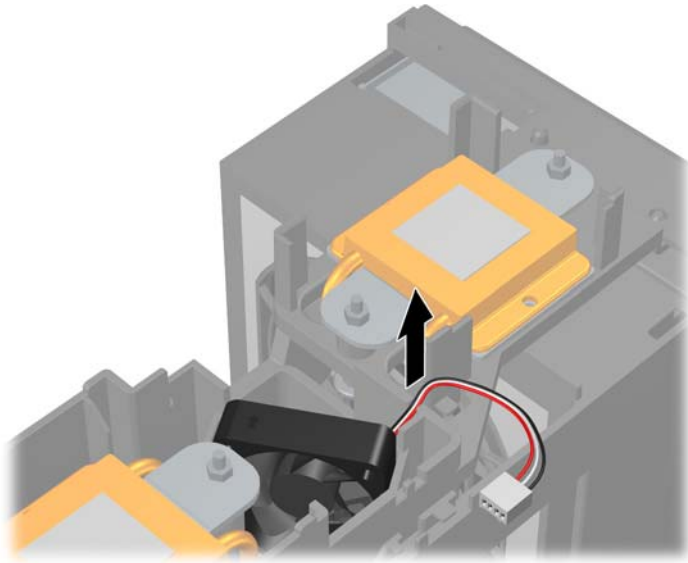

2. Remove the VRD fan from its holder. Grasp the fan and pull up.

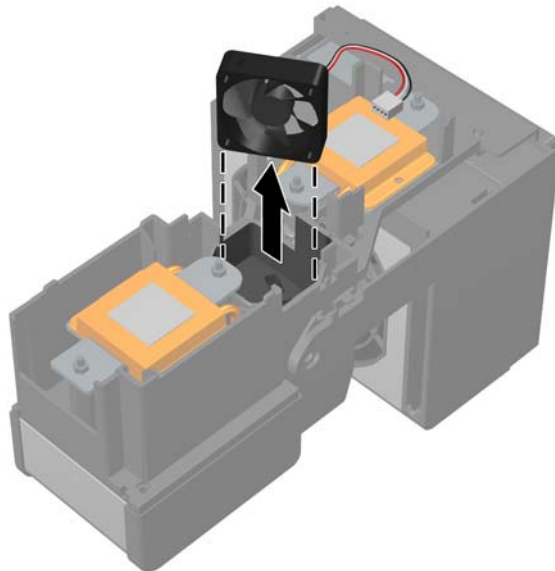

## Installing the VRD fan

To install the VRD fan:

1. Position the VRD fan such that the indicator arrow on the fan points in the same direction as the indicator arrow in the fan holder.

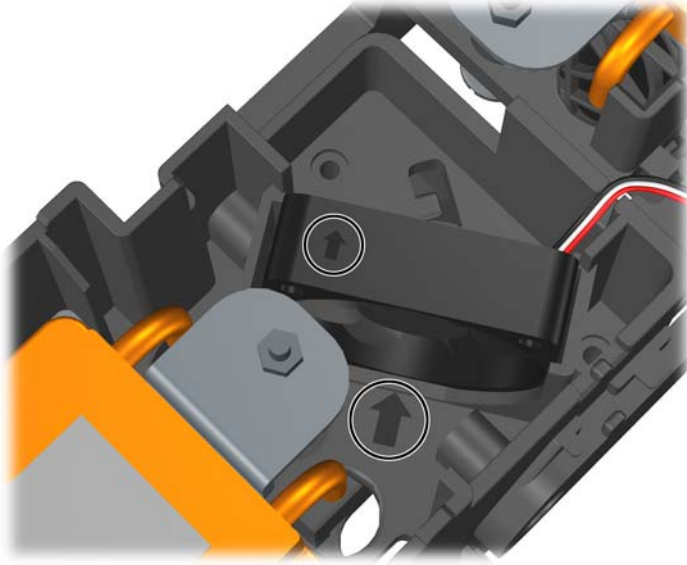

2. Insert the fan in its holder.

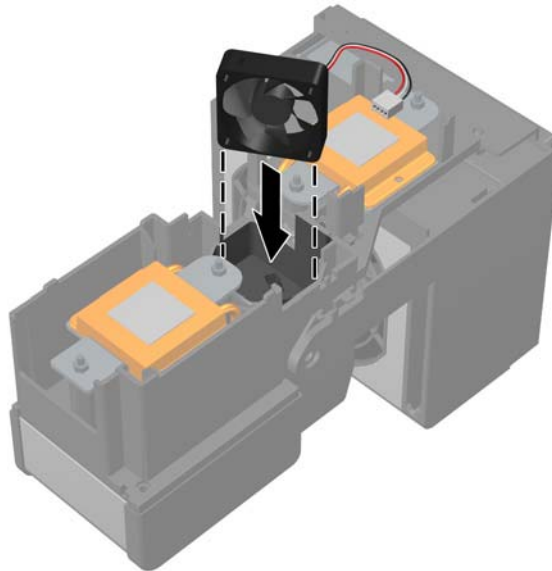

3. Press down until the fan snaps into place.

4. Position the VRD cable in the cable channel.

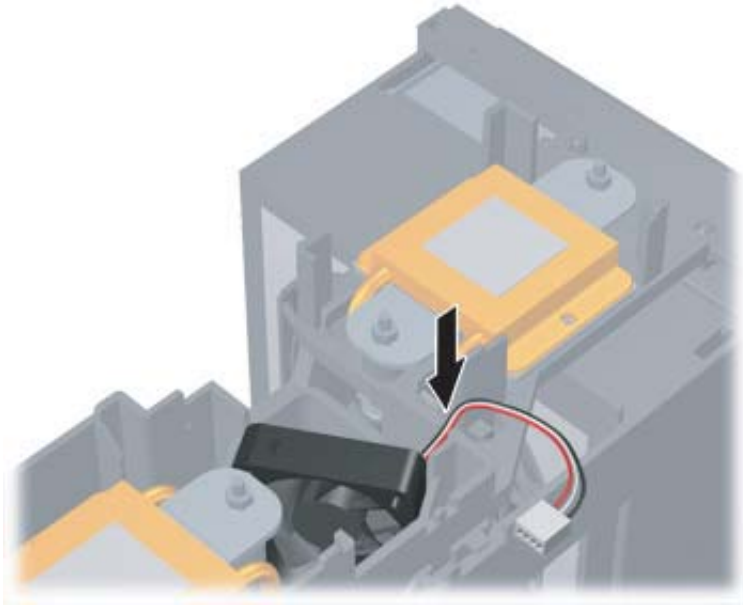

## Processor heatsink

### Removing the CPU heatsink

 **NOTE:** The following illustrated CPU heatsink is typical of what you might have in your workstation. Be aware that different variations of the CPU heatsinks exist, but the overall procedures listed are sufficient to assist you in removing the CPU heatsink.

1. Shut down the workstation, and disconnect power from the system ([Pre-disassembly procedures on page 55](#)). Remove the access panel ([Access panel on page 63](#)), and place the workstation on its side with the system board facing up.
2. Remove the two processor screws slowly, being sure to loosen the screws evenly. Loosen one screw **(1)** until the screw shank disengages from the system board, then loosen the remaining screw **(2)**. Do not fully loosen one screw, then move on to the next. Loosen both screws a little at a time, so that the processor remains level.

**Figure 5-69** Identifying proper screw removal order



3. Disconnect the CPU heatsink fan connector **(1)** from the system board. Loosen the heatsink mounting screws **(2)**.

4. Before lifting the heatsink, carefully break the thermal compound between the CPU heatsink and processor by moving the heatsink back and forth or twisting it **(3)**.

**Figure 5-70** Removing the CPU heatsink from the system board

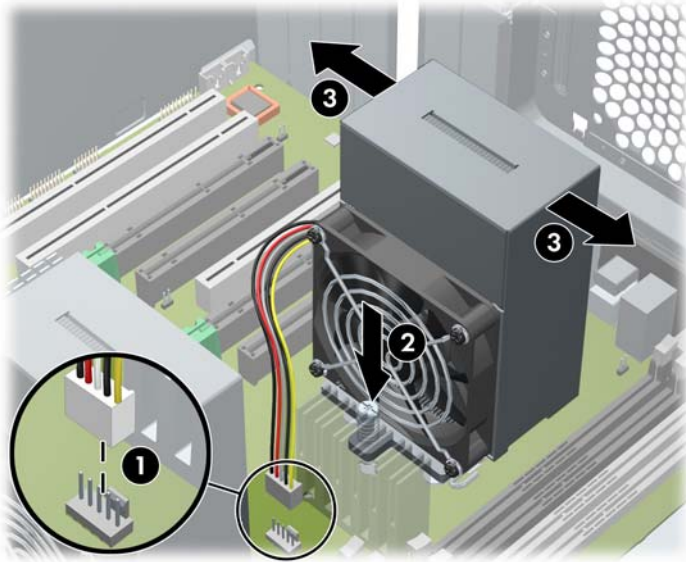

5. Use alcohol and a soft cloth to clean all of the thermal interface material residue from the CPU heatsink and processor.

△ **CAUTION:** Allow the alcohol on the processor and CPU heatsink to dry completely.



## Replacing the CPU heatsink

1. Disconnect power from the system ([Pre-disassembly procedures on page 55](#)). Remove the access panel ([Access panel on page 63](#)) and the CPU heatsink ([Removing the CPU heatsink on page 113](#)).
  2. Use alcohol and a soft cloth to clean all of the thermal grease from the CPU heatsink and processor.
- △ **CAUTION:** Allow the alcohol on the processor and CPU heatsink to dry completely.
3. Apply fresh thermal grease to the top of the processor in the pattern shown in the following figure.

**Figure 5-71** Applying thermal grease

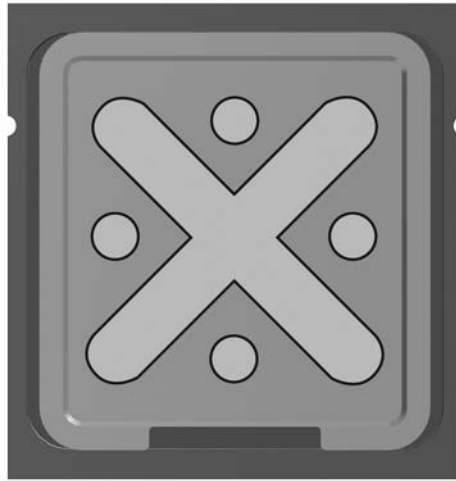

4. Place the CPU heatsink on top of the processor, and align the two mounting screws with the holes (1) in the system board.
- 📄 **NOTE:** If both CPU heatsinks were removed, be sure that all system board standoffs engage with the keyholes in the chassis, and that the system board connectors engage correctly with the rear I/O panel, and push back on the system board while engaging the CPU heatsink screws with the chassis standoffs. You only need to push back when trying to engage the first screw.

5. Connect the CPU heatsink fan connector to the system board **(2)**.

**Figure 5-72** Replacing the CPU heatsink on the system board

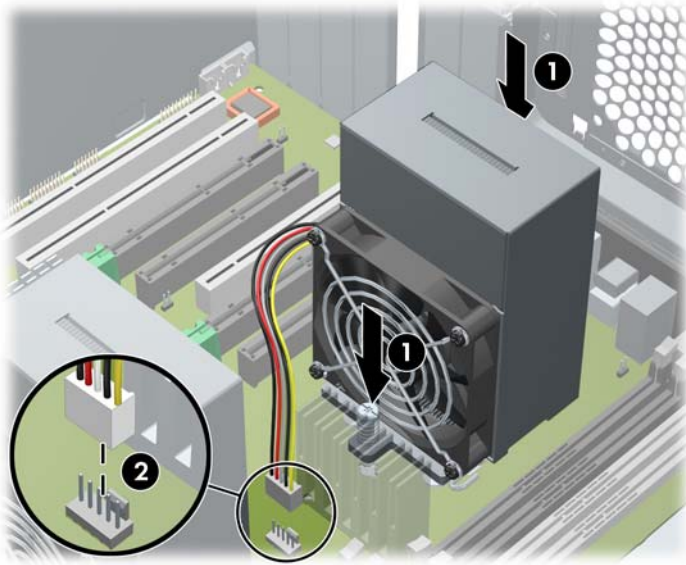

6. Insert and tighten the two CPU heatsink screws. First, tighten both screws partially so that the CPU heatsink remains level. Next, fully tighten one screw **(1)**, then fully tighten the remaining screw **(2)**. Tighten to a torque setting of 6 in-lb.

**Figure 5-73** Identifying proper screw removal order



## Processor

### Removing the processor

- △ **CAUTION:** Use **extreme** care when installing or removing a processor. The exposed socket pins are **extremely** fragile. Damaged sockets will require a board replacement.

**Lift** the processor out of the socket— **do not slide** the processor on the socket.

When installing a processor, align the dimples on the side of the processor with the notches in the socket.

1. Disconnect power from the system ([Pre-disassembly procedures on page 55](#)). Remove the access panel ([Access panel on page 63](#)) and the CPU heatsink ([Removing the CPU heatsink on page 113](#)).
2. Raise the processor socket handle fully **(1)** and lift the socket cover **(2)**.

**Figure 5-74** Raising the processor socket handle

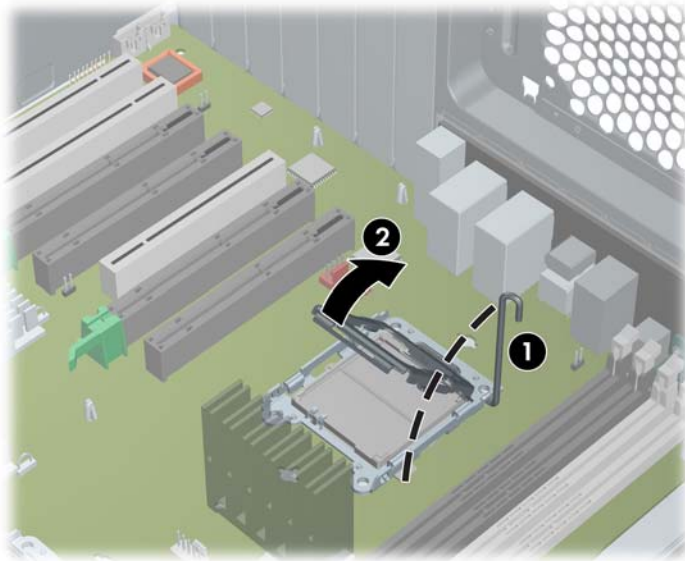

3. Lift the processor straight out of the socket.

**Figure 5-75** Lift the processor from the socket

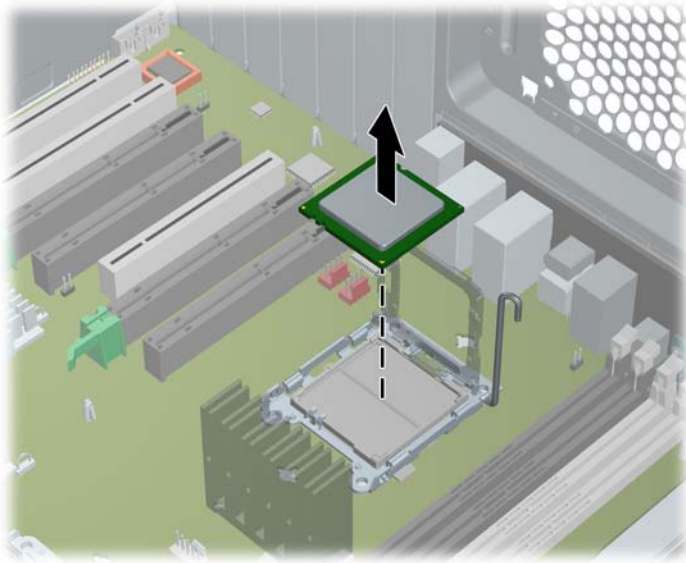

△ **CAUTION:** To avoid bending the socket pins, keep the processor perfectly flat when removing or installing it.

📄 **NOTE:** Store the processor in a static-free, safe place where it will not be damaged.

4. In some workstation configurations, a bypass board may be installed in the socket instead of a processor. Remove the bypass board by lifting it straight out of the socket.

**Figure 5-76** Lift the bypass board from the socket

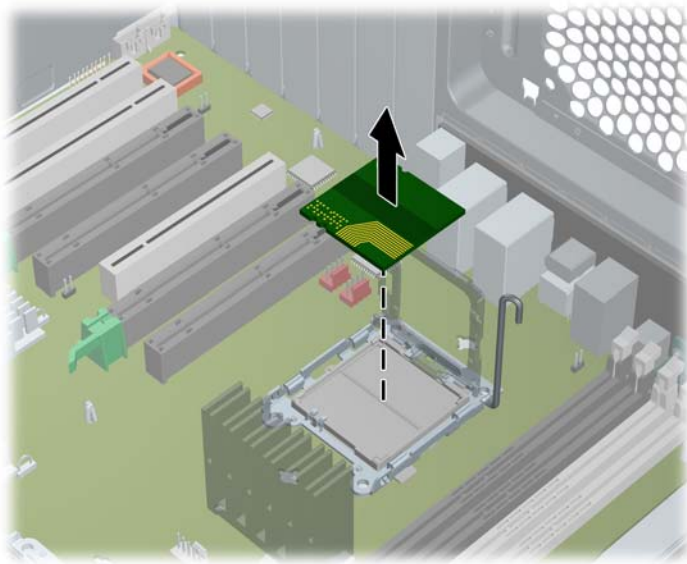

## Replacing the processor

△ **CAUTION:** HP recommends you **do not** swap processors (CPUs) from one motherboard to another.

△ **CAUTION:** Use **extreme** care when installing or removing a processor. The exposed socket pins are **extremely** fragile. Damaged sockets will require a board replacement.

**Lift** the processor out of the socket— **do not slide** the processor on the socket.

When installing a processor, align the dimples on the side of the processor with the notches in the socket.

1. Disconnect power from the system ([Pre-disassembly procedures on page 55](#)). Remove the access panel ([Access panel on page 63](#)), the CPU heatsink ([Removing the CPU heatsink on page 113](#)), and the processor ([Removing the processor on page 117](#)).
2. Raise the processor socket handle fully.
3. If necessary, remove the bypass board from the socket. Align the notches in the processor base with the tabs on the socket. Seat the processor into the socket. Ensure that the underside of the processor is level with the top of the processor socket. Close the processor cover plate. Lightly press down on the processor cover plate while closing the socket lever.

**Figure 5-77** Seating the processor

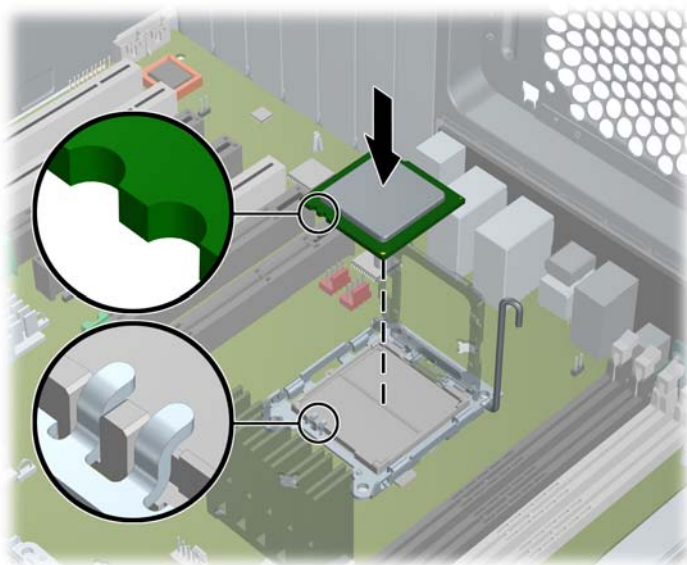

## System board

### Removing the system board

1. Disconnect power from the system ([Pre-disassembly procedures on page 55](#)), and remove the access panel ([Access panel on page 63](#)). Place the workstation on its side with the system board facing up. Remove all expansion boards, external cables, graphics cards ([Removing PCI or PCI Express cards on page 82](#)), and the CPU heatsink ([Processor heatsink on page 113](#)). Remove the system and memory fan assemblies.
2. Disconnect all cables from the system board.

 **NOTE:** Make note of the cable connections before disconnecting them from the system board. See [Power connections to drives on page 89](#) for more information.

3. Rotate the system board latch lever 90 degrees (1) clockwise to unlock the system board.
4. Slide the system board forward (2) to disengage the metal mounting standoffs from the chassis.

 **CAUTION:** Do **not** attempt to remove the system board mounting screws. These screws are permanently secured and are not removable.

5. Lift the system board out (3) of the chassis, being careful not to damage the cables and rear panel connectors. You can lift the board by the rear audio connector and the 2 x 4 power connector (4).

**Figure 5-78** Removing the system board

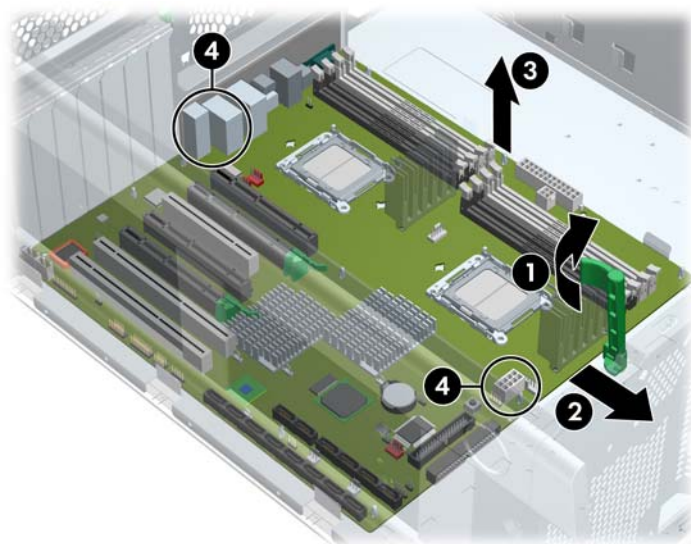

### Replacing the System Board

1. Insert the system board straight down, and be sure that all system board standoffs engage with the keyholes in the chassis.
-  **NOTE:** Be sure the system board connectors engage correctly with the rear I/O panel.
2. Push back on the board while maintaining downward pressure on the board, so all standoffs remain engaged.
  3. Rotate the system board latch 90 degrees counter clockwise.

4. Install the heatsink ([Replacing the CPU heatsink on page 115](#)).
5. Install all removed components and cables.

## Product recycling

HP encourages customers to recycle used electronic hardware, HP original print cartridges, and rechargeable batteries.

For information about recycling HP components or products, see <http://www.hp.com/go/recycle>.



---

## 6 System diagnostics and troubleshooting

This chapter discusses the tools available for diagnosing and troubleshooting system issues.

- [HP troubleshooting resources and tools on page 122](#)
- [Troubleshooting checklist on page 125](#)
- [LED color definitions on page 125](#)
- [Self-troubleshooting with HP Vision Field Diagnostics on page 126](#)
- [Diagnostic error codes on page 134](#)
- [Troubleshooting scenarios and solutions on page 137](#)
- [POST error messages on page 160](#)

### HP troubleshooting resources and tools

This section provides information on the HP Help and Support Center, E-support, and Helpful Hints for troubleshooting.

#### HP Help and Support Center

The HP Help and Support Center is a customized HP user interface that enhances the Windows XP Help and Support Center Help feature. This customized utility allows you to access specific information about your HP Workstation such as configuration information by clicking **Start > Help and Support Center**. The interface also provides customized help and support links to the HP Web site related to your HP Workstation.

---

 **NOTE:** The customized HP Help and Support Center is not available on Windows XP Professional x64 Edition or on Linux.

---

---

 **NOTE:** Currently, HP Help and Support Center does not work on Windows Vista.

---

#### E-support

Online access and support resources include Web-based troubleshooting tools, technical knowledge databases, driver and patch downloads, online communities, and product change notification services.

The following Web sites are also available to you:

- <http://www.hp.com>—Provides useful product information.
- [http://www.hp.com/support/workstation\\_manuals](http://www.hp.com/support/workstation_manuals)—Provides the latest online documentation.
- <http://www.hp.com/go/workstationsupport>—Provides technical support information for workstations.



- <http://www.hp.com/support>—Provides a listing of the worldwide technical support phone numbers. Access the telephone numbers by visiting the Web site, then select your region, and click **Contact HP** in the upper-left corner.
- [http://www.hp.com/support/workstation\\_swdrivers](http://www.hp.com/support/workstation_swdrivers)—Provides access to software and drivers for workstations.

## Troubleshooting a problem

To help you troubleshoot problems with your system, HP provides the Business Support Center (BSC). The BSC is a portal to an extensive selection of online tools. To access BSC and troubleshoot a problem with the workstation, complete the following:

1. Visit <http://www.hp.com/go/workstationsupport>.
2. Under the **Business Support Center** menu on the left, select **Troubleshoot a problem**.
3. Under **Select your product** (center window), select **Workstations** (under **personal computing**).
4. Under **Select your product**, continue with selections as appropriate to the workstation series and model, and to the problem you are troubleshooting.

## Instant Support and Active Chat

HP Instant Support is a set of Web-based support tools that automate and speed up the resolution of desktop computing, tape storage, and printing problems.

Active Chat enables you to electronically submit a support ticket to HP over the Web. When you submit a support ticket, Active Chat collects information about the computer and pass it to an online support specialist. The collection of information might take up to 30 seconds depending on the computer configuration. When you submit a support ticket, you receive a confirmation message containing your case ID, the support hours for your location, and the estimated time of response.

For more information about HP Instant Support and Active Chat and how to use them, visit [http://www.hp.com/hps/hardware/hw\\_professional.html](http://www.hp.com/hps/hardware/hw_professional.html).



**NOTE:** This feature is not available on Windows XP Professional x64 Edition or on Linux.

## Customer Advisories, Customer and Security Bulletins, and Customer Notices

To find advisories, bulletins, and notices:

1. Visit <http://www.hp.com/go/workstationsupport>.
2. Select the desired product.
3. Under **Resources for <your selected product>**, select **See more...**
4. Under **Self-Help resources:** in the center of the window, choose the desired action and appropriate information in the scroll list to view the index.

## Product Change Notifications

Product Change Notifications (PCNs) are proactive notifications for product changes occurring within a 30-60 day window of the effective date of the change in the manufacturing process. PCNs give customers advanced notice of changes to their product, such as an updated BIOS version that they may need to qualify prior to the change taking place. The latest PCNs are located at: <http://www.hp.com/go/workstationsupport>.

## Helpful hints

If you encounter a problem with the workstation, monitor, or software, the following provides a list of general suggestions that help you isolate and focus on the problem before taking further action.

### At startup

- Verify that the workstation and monitor are plugged into a working electrical outlet.
- Remove all diskettes, optical disks, and USB drive keys from the drives before powering on the workstation.
- Verify that the workstation is turned on and the green power light is on.
- If you have installed an operating system other than the factory-installed operating system, check to be sure that it is supported on your system by visiting <http://www.hp.com/go/quickspecs>.
- Verify that the monitor is turned on and the green monitor light is on.
- Turn up the brightness and contrast controls of the monitor if the monitor is dim.
- If the workstation has multiple video sources and only a single monitor, the monitor must be connected to the source selected as the primary VGA adapter. During startup, the other monitor connectors are disabled; if the monitor is connected to one of these ports, it will not function after Power-on Self Test (POST). You can select the default VGA source in Computer Setup (F10).

### During operation

- Look for blinking LEDs on the front of the workstation. The blinking lights are error codes that will help you diagnose the problem. Refer to the *Diagnostic lights and audible (beep) codes* section of this document for information on interpreting diagnostic lights and audible codes.
- Press and hold any key. If the system beeps, then your keyboard is operating correctly.
- Check all cables for loose or incorrect connections.
- Wake the workstation by pressing any key on the keyboard or the power button. If the system remains in suspend mode, shut down the system by pressing and holding the power button for at least four seconds, then press the power button again to restart the system. If the system does not shut down, unplug the power cord, wait a few seconds, then plug it in again. If it does not restart, press the power button to start the workstation.
- Reconfigure the workstation after installing a non–plug and play expansion board or other option. Refer to the *Hardware installation problems* section of this document for instructions.
- Be sure that all required device drivers have been installed. For example, if you have connected a printer, you must install a printer driver.
- If you are working on a network, plug another workstation with a different cable into the network connection. There might be a problem with the network plug or cable.
- If you recently added new hardware, remove the hardware and verify if the workstation functions properly.
- If you recently installed new software, uninstall the software and verify if the workstation functions properly.
- If the screen is blank, plug the monitor into a different video port on the workstation if one is available. Alternatively, replace the monitor with a monitor that you know is working properly.

- Upgrade the BIOS. A new release of the BIOS might have been released that supports new features or fixes your problem.
- For more detailed information, see the troubleshooting chapter in the *Service and Technical Reference Guide* at [http://www.hp.com/support/workstation\\_manuals](http://www.hp.com/support/workstation_manuals).

## Customizing the monitor display

You can manually select or change the monitor model, refresh rates, screen resolution, color settings, font sizes, and power management settings. To do so, right-click the desktop, then click **Properties** to change display settings. For more information, see the online documentation provided with the graphics controller utility or the documentation that came with your monitor.

## Troubleshooting checklist

Before running diagnostic utilities, use the following checklist to find possible solutions for workstation or software problems.

- Is the workstation and monitor connected to a working electrical outlet?
- Is the workstation powered on?
- Is the green power light illuminated?
- Is the monitor on?
- Is the green monitor light illuminated?
- If the monitor is dim, adjust the monitor brightness and contrast controls.
- Press and hold any key. If the system beeps, the keyboard is operating correctly.
- Check cables for loose or improper connections.
- After installing a non-plug and play (PnP) expansion board or other option (such as a diskette drive), reconfigure the workstation.
- Are all necessary device drivers installed?
- Have all printer drivers been installed for each application?
- Have you removed diskettes, optical disks, and USB drive keys from the drives before powering on the workstation?
- Are you running the latest version of BIOS, drivers, and software?

## LED color definitions

The front panel LED indicates system status as described in Table 1.

**Table 6-1** Front panel LED color definitions

LED State	LED Color	System Status
Solid	Green	System is on.
Blinking	Green	System is in Standby mode.
Solid or blinking	Red	System has an error. See <a href="#">Diagnostic light codes on page 134</a> .
None	No light	System is in Hibernate mode, or it is off.

# Self-troubleshooting with HP Vision Field Diagnostics

Hewlett-Packard Vision Field Diagnostics is a diagnostic tool that can be used by the end user or technical support personnel to view information about the hardware configuration of the computer and perform hardware troubleshooting on HP Desktop and Workstation systems. This diagnostic tool should be used to help determine hardware failures. Accessible by either CD or USB key, these diagnostics run outside the operating system and so make it easy to isolate potential issues that may be operating system related versus hardware.

HP Vision Field Diagnostics benefits are:

- Capture complete system configuration information that can be shared as an HTML file, including:
  - System serial number
  - System product number
  - System BIOS revision
  - Memory size and configuration
  - Processor information
  - Storage device information and configuration
  - Graphics / audio / communications information and configuration
  - And more...
- Comprehensive list of diagnostic test available with new added features:
  - Highly configurable testing options: quick / complete / custom / interactive / non-interactive
  - Specific failing memory DIMM identification
  - Tests video card memory
  - Launches DST Smart tests for both SATA and SAS drives
  - Many other tests and diagnostics
- Warranty Code output – A unique warranty code is generated for each failure which can be used to validate diagnostic use for a specific system
- Easy to use - uses similar user interface as previous field diagnostics, HP Insight Diagnostics
- True End2End diagnostics – same diagnostics modules used in factory
- Easy to obtain
  - Download from Web
  - USB key bootable or CD bootable
  - Included with restore media

It is expected that these Vision diagnostics will be run on supported products when attempting to troubleshoot system issues.

## Overview

The HP Vision Field Diagnostics utility allows you to view information about the hardware configuration of the workstation and perform hardware diagnostic tests on the subsystems of the workstation. The utility simplifies the process of effectively identifying, diagnosing, and isolating hardware issues.

The Survey tab is displayed when you invoke HP Vision Field Diagnostics. This tab shows the current configuration of the workstation. From the Survey tab, there is access to several categories of information about the workstation. Other tabs provide additional information, including diagnostic test options and test results. The information in each screen of the utility can be saved as an html file and stored on a diskette or USB flash drive.

Use HP Vision Field Diagnostics to determine if all the devices installed on the workstation are recognized by the system and functioning properly. Running tests is optional but recommended after installing or connecting a new device.

You should run tests, save the test results, and print them so that you have printed reports available before placing a call to the Customer Support Center.

---

 **NOTE:** Third-party devices may not be detected by HP Vision Field Diagnostics.

---

## Downloading and accessing HP Vision Field Diagnostics

To access HP Vision Field Diagnostics the utility has to be downloaded from the HP Web site and copied to CD or USB drive.

1. Go to <http://www.hp.com>.
2. Select the **Support & Drivers** link.
3. Select the **Download driver and software** radio button.
4. Enter your product number (for example, Z800) in the text box, and then press **Enter**.
5. Select your operating system.
6. Select the **Diagnostic** link.
7. Locate **HP Vision Field Diagnostics** and select **Download**.
8. After the *.iso* file is downloaded, use CD-ROM burning software to copy the *.iso* file to an optical medium or USB flash drive.
9. When the CD or USB flash drive has the utility installed, insert the CD or USB flash drive into the workstation (while it is on).
10. Shut down the operating system and turn off the workstation.
11. Turn on the workstation. The system will boot into HP Vision Field Diagnostics.

---

 **NOTE:** If the system does not boot to the CD in the optical drive or to the USB flash drive, you may need to change the boot order in the Computer Setup (F10) utility.

---

12. At the boot menu, select either the **HP Vision Field Diagnostics** utility to test the various hardware components in the computer or the **HP Memory Test** utility to test memory only.

---

 **NOTE:** The HP Memory Test is a comprehensive memory diagnostic utility that is run as a stand-alone application, outside of HP Vision Field Diagnostics.

---

13. If running HP Vision Field Diagnostics, select the appropriate language and click **Continue**.
14. In the End User License Agreement page, select **Agree** if you agree with the terms. The HP Vision Field Diagnostics utility launches with the Survey tab displayed

## User interface

The HP Vision Field Diagnostics application provides six major functions, accessible through Tabs. These functions are:

- **Survey** — Your current system hardware information.
- **Test** — List all diagnostics available for your system. Tests are started there.
- **Status** — This screen shows progress and status of currently running diagnostics.
- **History** — All past diagnostics runs and status are listed there.
- **Errors** — All past diagnostics failures are listed there.
- **Help** — User help about HP Vision Diagnostics.

There are also some common operations that are part of the utility. They include:

- **Exit Diagnostics** button — This button will close HP Vision Diagnostic application and reboot your system. Any running test will be aborted.
- **Reload** button — If available, this button will rescan your system hardware and reload the diagnostics without the need to restart your entire system.
- **Save** button — If available, save your system survey, test history or error data as an HTML file to a floppy disk or a USB key drive.

## Survey tab

The Survey tab shows your system hardware information, organized into eleven Categories (for example "Processors") and device instances (for example "Processor 1").

The amount of information displayed can be controlled by selecting a combination of View Level and Category.

The **View Levels** include:

- **Overview** — shows high level summary of the system hardware. This is the default view level.
- **Summary** — gives limited configuration data for each specific Category.
- **Advanced** — offers more technical and low-level data for the computer-savvy user.

The **Categories Levels** include:

- **All** — Shows all Categories.
- **Architecture** — Shows system architecture information such as high level PCI devices, low level SMBIOS, CMOS and PCI configuration space data.
- **Audio** — Shows all embedded and add-on audio devices.
- **Asset Control** — Shows asset control related information such as product name, serial number, asset tag, and universal unique ID information.
- **Communication** — Shows communication devices such as serial, parallel, USB, network, Firewire, modem, and Bluetooth ports and devices.
- **Graphics** — Shows all embedded and add-on video cards.
- **Input Devices** — Shows user input devices such as all connected mice and keyboards.
- **Memory** — Shows system memory information.

- **Miscellaneous** — List any devices or data that doesn't belong to any other Category.
- **Processors** - Shows system processors.
- **Storage** — Shows mass storage devices such as floppy drives, optical drives, SATA, SAS hard disk drives and controllers, as well as any RAID arrays.
- **System** — Shows information about motherboard devices such as fans and cables.

## Test tab

The Test tab lists all available diagnostics. The lists have been tailored according to your system configuration. Individual test may be selected or unselected. The following Test Modes exist:

- **Quick** — This test selection was picked to perform quickly while covering your entire hardware. Test parameters cannot be modified.
- **Complete** — This test selection offers all available tests and may take a long time to complete. Test parameters cannot be modified.
- **Custom** — Like Complete this test selection offers all available tests. The test parameters may be modified to fit specific needs. For advanced users only!

By default, the three test modes do not display prompts and require no interaction. If errors are found, they are displayed when testing is complete.

However, for each test type, you may also optionally add interactive tests by clicking the **Include interactive tests** box under Test mode. Selecting interactive tests provides the maximum control over the testing process. The diagnostic software will prompt you for input during tests.

---

 **NOTE:** Memory can not be tested from within the HP Vision Field Diagnostics application. To test the memory in your workstation, exit HP Vision Field Diagnostic, boot to either the CD or USB flash drive and select **HP Memory Test** from the boot menu.

---

The **Duration of Test** options control the duration of the test sequence. The following options are available:

- **Number of loops** — A test selection will run once by default. Enter a positive number to make a test selection run many times.
- **Total test time (hours:minutes)** — Alternatively, the test selection can be set to run for a specified amount of time. This does not guarantee that all tests will run if the entered time is less than the necessary time to run all the tests
- **Stop at first error**— Check this option to stop test execution as soon as one error is encountered.

The following **Test Controls** exist:

- **Select All, Unselect All** button — This button toggles to select or unselect all the tests from the test selection tree.
- **Expand, Collapse** button — This button toggles to expand or collapse the test selection tree.
- **Start Test** button — Click this button to start executing all selected tests. HP Vision Field Diagnostics will automatically switch to the Status tab in order to keep track of the test execution and status.

---

 **WARNING!** Once started, do not reboot or power off your computer until all the tests have been completed.

---

To begin testing:

1. Select the Test tab.
2. Select the type of tests you want to run: **Quick**, **Complete**, or **Custom**.
3. Include optional interactive tests by selecting **Include interactive tests**.
4. Choose how you want the test to be executed, either **Number of Loops** or **Total Test Time**. When choosing to run the test over a specified number of loops, enter the number of loops to perform. If you want the diagnostic test for a specified time period, enter the amount of time in minutes.



5. Click the **Start Test** button to start the testing. The Status tab, which allows you to monitor the progress of the tests, is automatically displayed during the testing process. When the tests are complete, the Status tab shows whether the devices passed or failed.
6. If errors are found, go to the Errors tab to display detailed information and recommended actions.

## Status tab

The Status tab shows the overall progress and status of the test scenario as well as the progress and status of each test. The color coded status are black, blue, green, red, and orange.

The Status tab colors are:

- **Waiting** (black) — when no test is running
- **Running** (blue) — when at least one test is currently running
- **Passed** (green) — when all tests have run successfully, meaning that no hardware error or defect have been detected
- **Failed** (red) — when three tests have detected at least one error with your system
- **Canceled** (orange) — when the test scenario has been explicitly canceled, in which case no pass or fail conclusion can be drawn

The available data is:

- **Current Loop** — Shows the current execution loop out of total number of loops specified in the Test panel.
- **Test Time** — Shows the total time elapsed since the beginning of the test execution.
- **Test Complete** — Shows the number of tests successfully completed out of the total number of test to execute.
- **Cancel** button — Push the Cancel button to immediately terminate all currently running tests.

## History tab

The History tab shows the history of the past test executions.

The History Log displays all tests that have been executed, the number of times of execution, the number of times failed, the date each test was executed, and the time it took to complete each test. The **Clear History** button will clear the contents of the History Log.

The contents of the History Log may be saved as a HTML file to either floppy or USB flash drive by clicking the **Save** button.

## Errors tab

The Errors tab displays detailed information about any errors found, as well as any recommended actions.

The Error Log displays the tests for devices that have failed during the diagnostic testing and includes the following columns of information.

- The Device section displays the device tested.
- The Test section displays the type of test run.
- The Times Failed is the number of times the device has failed a test.
- The Defect Code provides a numerical code for the failure. The error codes are defined in the Help tab.
- The Description section describes the error that the diagnostic test found.
- The Reason section describes the likely cause of the error.

- The Recommended Repair will give a recommended action that should be performed to resolve the failed hardware.
- The Warranty ID is a unique error code associated with the specific error on your computer. When contacting the HP Support Center for assistance with a hardware failure, please be prepared to provide the Warranty ID.
- The Clear Errors button will clear the contents of the Error Log.

The contents of the Error Log may be saved as a HTML file to either floppy or USB flash drive by clicking the **Save** button.

## Help tab

The Help tab contains a Vision Help section, and a Test Components section. This tab includes search and index features. You may also review the HP End User License Agreement (EULA), as well as the HP Vision Field Diagnostic application version information on this tab.

The various sections located here are:

- The Vision Help section contains information on the major functions of HP Vision Field Diagnostics.
- The Test components section provides a description of each test, as well as the parameters that may be adjusted when running in Custom test mode.
- The Defect codes section contains information on the numerical error code that may appear in the Errors tab.
- The Memory test tab section provides information on the HP Memory Test application that may be launched from the boot menu.
- The HP Support section provides information on obtaining technical support from HP.

## Saving and printing information in HP Vision Field Diagnostics

You can save the information displayed in the HP Vision Field Diagnostics Survey, History and Errors tabs to a diskette or a USB flash drive. You can not save to the hard drive. The system will automatically create an html file that has the same appearance as the information displayed on the screen.

1. Insert a diskette or USB flash drive if running HP Vision Field Diagnostics from CD.
2. Click **Save** in the bottom on any of the Survey, History or Errors tabs. All three log files will be saved regardless of from which tab the Save button was clicked.
3. Select the drive onto which you will save the log files and click the **Save** button. Three html files will be saved to the inserted diskette or USB flash drive.

---

 **NOTE:** Do not remove the diskette or USB key until you see a message indicating that the html files have been written to the media.

---

4. Print the desired information from the storage device used to save it.

---

 **NOTE:** To exit HP Vision Field Diagnostics, click the **Exit Diagnostics** button at the bottom of the screen. Be sure to remove the USB flash drive or CD from the optical drive.

---

## Downloading the latest diagnostic utility

Follow these steps to download the latest diagnostic utility:

1. Go to <http://www.hp.com>.
2. Select the **Support & Drivers** link.
3. Select the **Download driver and software** radio button.
4. Enter your product number (for example, **Z800**) in the text box, and then press **Enter**.
5. Select your operating system.
6. Select the **Diagnostic** link.
7. Locate **HP Vision Field Diagnostics** and select **Download**.
8. After the .iso file is downloaded, use CD-ROM burning software to copy the .iso file to an optical medium.

## Diagnostic error codes

This sections provides an overview of the diagnostic lights and error codes that are related to your workstation.

### Diagnostic light codes

---

 **NOTE:** The beeps are heard through the chassis speaker. The blinking LEDs and beeps repeat for five cycles. After that, only the blinking LEDs repeat.

---

**Table 6-2 Diagnostic LED codes**

<b>Chassis Indicator LEDs</b>	
<b>Power LED and Sound Activity</b>	<b>Diagnosis and Service Action</b>
None	<p><b>CAUTION:</b> Disconnect AC power from the workstation before reseating or replacing components because there is power to the system board even when the workstation is powered down.</p> <p>System does not power on. Press power button. If HDD LED = GREEN, then:</p> <ol style="list-style-type: none"> <li>1. Remove expansion cards one at a time.</li> <li>2. Replace the system board.</li> </ol> <p>OR</p> <p>If HDD LED does not illuminate, then:</p> <ol style="list-style-type: none"> <li>1. Verify that the unit is plugged into a working AC outlet.</li> <li>2. Open access panel, and verify that the power button harness is properly connected to the inline front panel I/O device assembly connector.</li> <li>3. Verify that the power supply cables are properly connected to the system board.</li> <li>4. Verify the power supply functionality.               <ol style="list-style-type: none"> <li>a. Disconnect AC power.</li> <li>b. Remove all internal power supply cables from the system board.</li> <li>c. Plug in AC power.                   <ul style="list-style-type: none"> <li>• If the power supply fan spins and the BIST* LED lights, then the power supply is good. Replace the system board.</li> <li>• If the power supply fan does not spin or the BIST* LED does not light, replace the power supply.</li> </ul> </li> </ol> </li> </ol>
Blinks red/beeps two times, once per second, then two-second pause	<p>Thermal shutdown.</p> <ol style="list-style-type: none"> <li>1. Ensure that the workstation system air vents are not blocked and the cooling fan is running.</li> <li>2. Open the access panel, press power button, and see if the processor fan spins. Check both fans for a dual-processor workstation. If the processor fan is not spinning, make sure the fan's cable is plugged into the system board header. Ensure the fan is fully/properly seated or installed.</li> <li>3. If fan is plugged in and seated properly, but is not spinning, the problem may be in the processor fan. Contact HP for assistance</li> <li>4. Verify that the fan assembly is properly attached. If problems persist, there may be a problem with the processor heatsink. Contact HP for assistance.</li> </ol>
Blinks red/beeps three times, once per second, then a two-second pause	<p><b>CAUTION:</b> Disconnect AC power from the workstation before reseating or replacing components because there is power to the system board even when the workstation is powered down.</p> <p>CPU not installed.</p> <ol style="list-style-type: none"> <li>1. Check to see that the processor is present.</li> <li>2. Reseat the processor.</li> </ol>

**Table 6-2 Diagnostic LED codes (continued)**

<b>Chassis Indicator LEDs</b>	
<b>Power LED and Sound Activity</b>	<b>Diagnosis and Service Action</b>
Blinks red/beeps four times, once per second, then a two-second pause	<p><b>CAUTION:</b> Disconnect AC power from the workstation before reseating or replacing components because there is power to the system board even when the workstation is powered down.</p> <p>Power supply failure.</p> <ol style="list-style-type: none"><li>1. Open the access panel and ensure the following connections are secure on the system board:<ul style="list-style-type: none"><li>◦ 24-pin main power</li><li>◦ 8-pin CPU</li><li>◦ 4-pin memory</li></ul></li><li>2. Locate faulty device by removing all devices and then reinstalling one at a time until workstation fails. Replace the device causing the failure. Continue adding devices to ensure all are functioning properly.</li><li>3. Verify power supply functionality.<ol style="list-style-type: none"><li>a. Disconnect AC power.</li><li>b. Remove all internal power supply cables from the system board.</li><li>c. Plug in AC power.<ul style="list-style-type: none"><li>• If the power supply fan spins and the BIST* LED lights, then the power supply is good. Replace the system board.</li><li>• If the power supply fan does not spin or the BIST* LED does not light, replace the power supply.</li></ul></li></ol></li></ol>
Blinks red/beeps five times, once per second, then two-second pause	<p><b>CAUTION:</b> Disconnect AC power from the workstation before reseating or replacing components because there is power to the system board even when the workstation is powered down.</p> <p>Pre-video memory error.</p> <ol style="list-style-type: none"><li>1. Ensure DIMMs are loaded in correct slots.</li><li>2. Reseat DIMMs.</li><li>3. Replace DIMMs one at a time to isolate faulty module.</li><li>4. Replace third-party memory with HP memory.</li><li>5. Reseat CPUs.</li><li>6. Replace system board.</li></ol>
Blinks red/beeps six times, once per second, then a two-second pause	<p><b>CAUTION:</b> Disconnect AC power from the workstation before reseating or replacing components because there is power to the system board even when the workstation is powered down.</p> <p>Pre-video graphics card error.</p> <ol style="list-style-type: none"><li>1. Ensure auxiliary power cable is connected if applicable (high power graphics cards only).</li><li>2. Reseat the graphics card.</li><li>3. Replace the graphics card.</li><li>4. Replace the system board.</li></ol>

**Table 6-2 Diagnostic LED codes (continued)**

Chassis Indicator LEDs	
Power LED and Sound Activity	Diagnosis and Service Action
Blinks red/beeps seven times, once per second, then a two-second pause	<p><b>CAUTION:</b> Disconnect AC power from the workstation before reseating or replacing components because there is power to the system board even when the workstation is powered down.</p> <p>System board failure (ROM detected failure before video).</p> <ol style="list-style-type: none"> <li>1. Clear CMOS by pressing the Clear CMOS button on the system board.</li> <li>2. Replace system board.</li> </ol>
Blinks red/beeps eight times, once per second, then a two-second pause	<p><b>CAUTION:</b> Disconnect AC power from the workstation before reseating or replacing components because there is power to the system board even when the workstation is powered down.</p> <p>Invalid ROM based on bad checksum.</p> <ol style="list-style-type: none"> <li>1. Clear CMOS by pressing the Clear CMOS button on the system board.</li> <li>2. Upgrade the ROM using a ROMPaq diskette, CD, diskette, or USB removable device (e.g., HP Drive Key). See the <i>ROM Flash</i> section of the <i>Service and Technical Reference Guide</i> at <a href="http://www.hp.com/support/workstation_manuals">http://www.hp.com/support/workstation_manuals</a>.</li> <li>3. Replace system board.</li> </ol>
Blinks red/beeps nine times, once per second, then a two-second pause	<p><b>CAUTION:</b> Disconnect AC power from the workstation before reseating or replacing components because there is power to the system board even when the workstation is powered down.</p> <p>System powers on but is unable to boot.</p> <ol style="list-style-type: none"> <li>1. Replace the processor.</li> <li>2. Replace the system board.</li> </ol>

\* Refer to the *Service and Technical Reference Guide* for your workstation for BIST information.

## Troubleshooting scenarios and solutions

This section presents an extensive overview of various troubleshooting scenarios and includes possible solutions for each.

### Solving minor problems

**Table 6-3 Minor problems**

Problem	Cause	Possible Solution
Workstation seems to be locked up.	Program in use has stopped responding to commands.	<ol style="list-style-type: none"> <li>1. Attempt the normal Windows shut down procedure.</li> <li>2. Restart the workstation using the power button.</li> </ol>
Workstation appears locked up and will not turn off when the power button is pressed.	Software control of the power switch is not functional.	<ol style="list-style-type: none"> <li>1. Press and hold the power button for at least four seconds until the workstation turns off.</li> <li>2. Disconnect electrical plug from outlet.</li> </ol>

**Table 6-3** Minor problems (continued)

<b>Problem</b>	<b>Cause</b>	<b>Possible Solution</b>
Workstation date and time display is incorrect.	Real-time clock (RTC) battery might need to be replaced.	<ol style="list-style-type: none"><li>1. Reset the date and time under Control Panel.</li><li>2. Replace the RTC battery.</li></ol>
Workstation appears to pause periodically.	Network driver is loaded and no network connection is established.	Establish a network connection, or use Computer Setup or Microsoft Windows Device Manager to disable the network controller.
Cursor will not move using the arrow keys on the keypad.	The <b>Num Lock</b> key might be on.	Press <b>Num Lock</b> . The Num Lock key can be disabled (or enabled) in Computer Setup.
Poor performance is experienced.	Processor is hot.	<ol style="list-style-type: none"><li>1. Be sure airflow to the workstation is not blocked.</li><li>2. Be sure the fans are connected and working properly (some fans only operate when needed).</li><li>3. Be sure the CPU heatsink is installed properly.</li></ol>
	There is not enough memory.	<b>CAUTION:</b> Disconnect AC power from the workstation before reseating or replacing components because there is power to the system board even when the workstation is powered down. Add more memory.
	Hard drive is full.	Delete data from the hard drive to create more space on the hard drive.



**Table 6-3 Minor problems (continued)**

Problem	Cause	Possible Solution
<p>Workstation powered off automatically and the Power LED flashes red two times, once every second, followed by a two-second pause, and two simultaneous beeps are heard.</p>	<p>Processor thermal protection activated: A fan might be blocked or not turning. OR The CPU heatsink is not properly attached to the processor.</p>	<p><b>CAUTION:</b> Disconnect AC power from the workstation before reseating or replacing components because there is power to the system board even when the workstation is powered down.</p> <ol style="list-style-type: none"> <li>1. Check system and CPU fan cables.</li> <li>2. Be sure workstation air vents are not blocked and the cooling fan is running.</li> <li>3. Open the access panel, press the power button, and determine if the processor fan spins. If not spinning, be sure the fan's cable is plugged into the system board header. Be sure the fan is fully/properly seated or installed.</li> <li>4. Replace the processor fan.</li> <li>5. Reseat CPU heatsink and verify that the fan assembly is properly attached.</li> </ol>
<p>Workstation does not power on and the LEDs on the front of the workstation are not flashing.</p>	<p>System unable to power on.</p>	<p><b>CAUTION:</b> Disconnect AC power from the workstation before reseating or replacing components because there is power to the system board even when the workstation is powered down.</p> <p>Press and hold the power button for less than four seconds. If the hard drive LED turns green, then:</p> <ol style="list-style-type: none"> <li>1. Remove the expansion cards.</li> <li>2. Replace the system board.</li> </ol> <p>OR</p> <p>If the HDD LED does not illuminate, then:</p> <ol style="list-style-type: none"> <li>1. Verify that the unit is plugged into a working AC outlet.</li> <li>2. Open the access panel, and verify that the power button harness is properly connected to the inline front panel I/O device assembly connector.</li> <li>3. Verify that the power supply cables are properly connected to the system board.</li> <li>4. Verify power supply functionality:               <ol style="list-style-type: none"> <li>a. Disconnect AC power.</li> <li>b. Remove all internal power supply cables from the system board.</li> <li>c. Plug in AC power.                   <ul style="list-style-type: none"> <li>• If the power supply fan spins and the BIST* LED lights, then the power supply is good. Replace the system board.</li> <li>• If the power supply fan does not spin or the BIST* LED does not light, replace the power supply.</li> </ul> </li> </ol> </li> </ol>

## Solving power supply problems

### Testing power supply

Before reseating or replacing the power supply, use the BIST feature to determine if the power supply still works.

To test the power supply:

1. Disconnect AC power to the workstation.
2. Disconnect all internal power supply cables.
3. Plug in AC power.
  - a. If the green BIST LED on the rear of the workstation is lit **and** the fan is spinning, the power supply is functional.
  - b. If the green BIST LED is not lit **or** the fan is not spinning, replace the power supply.

**Figure 6-1** BIST LED

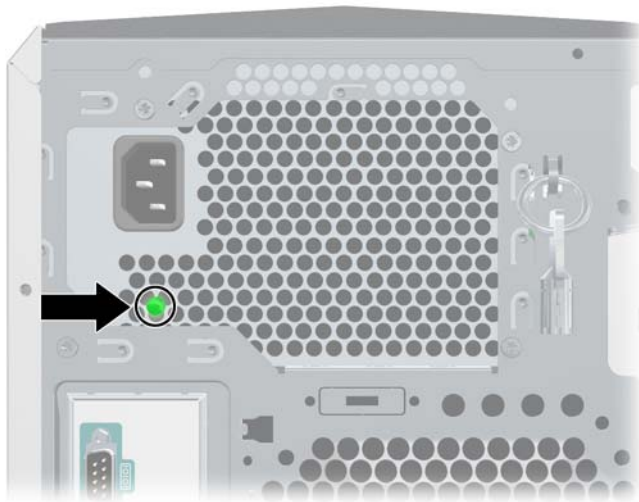

**Table 6-4** Power supply problems

Problem	Cause	Solution
Power supply shuts down intermittently.	Power supply fault.	Replace the power supply.

**Table 6-4 Power supply problems (continued)**

Problem	Cause	Solution
Workstation powered off automatically and the Power LED flashes red two times, once every second, followed by a two-second pause.	<p>Processor thermal protection activated.</p> <p>A fan might be blocked or not turning.</p> <p>OR</p> <p>The CPU heatsink fan assembly is not properly attached to the processor.</p>	<p><b>CAUTION:</b> Disconnect AC power from the workstation before reseating or replacing components because there is power to the system board even when the workstation is powered down.</p> <ol style="list-style-type: none"> <li>1. Be sure that the workstation air vents are not blocked and the cooling fan is running.</li> <li>2. Open the access panel, press the power button, and determine if the processor fan spins. If the processor fan is not spinning, be sure the fan's cable is plugged into the system board header. Be sure the fan is properly seated or installed.</li> <li>3. Check processor fan cables.</li> <li>4. Replace the processor fan.</li> <li>5. Reseat the CPU heatsink, and verify that the fan assembly is properly attached.</li> </ol>
Power LED flashes red, once every two seconds.	Power failure (power supply is overloaded).	<p><b>CAUTION:</b> Disconnect AC power from the workstation before reseating or replacing components because there is power to the system board even when the workstation is powered down.</p> <ol style="list-style-type: none"> <li>1. Determine whether a device is causing the problem by removing all attached devices. Power on the system. If the system enters the POST, then power off and replace one device at a time and repeat this procedure until failure occurs. Replace the device causing the failure. Continue adding devices one at a time to ensure all devices are functioning properly.</li> <li>2. Verify power supply functionality.               <ol style="list-style-type: none"> <li>a. Disconnect AC power.</li> <li>b. Remove all internal power supply cables from the system board.</li> <li>c. Plug in AC power.                   <ul style="list-style-type: none"> <li>• If the power supply fan spins and the BIST LED lights, then the power supply is good. Replace the system board.</li> <li>• If the power supply fan does not spin or the BIST LED does not light, replace the power supply.</li> </ul> </li> </ol> </li> </ol>

## Solving diskette problems

**Table 6-5** Diskette problems

Problem	Cause	Solution
Diskette drive light stays on.	Diskette is damaged.	<ol style="list-style-type: none"> <li>1. Check power and data cables.</li> <li>2. Click on <b>My Computer</b>.</li> <li>3. Right-click on the desired hard drive and select <b>Properties</b>.</li> <li>4. Click the <b>Tools</b> tab.</li> <li>5. Click <b>Check Now...</b> to run error checking.</li> </ol>
	Diskette is incorrectly inserted.	Remove diskette and reinsert.
	Files on diskette are damaged.	Check the program diskettes.
	Drive cable is not properly connected.	Reconnect power cable. Be sure that all four pins are connected.
Drive not found.	Cable is loose.	Reseat diskette drive data and power cables.
	Removable drive is not seated properly.	Reseat the drive.
Diskette drive cannot write to a diskette.	Diskette is not formatted.	Format the diskette.
	Diskette is write-protected.	Use another diskette or remove the write protection.
	Writing to the wrong drive.	Check the drive letter in the path statement.
	Not enough space is left on the diskette.	Use another diskette.
	Diskette write control is enabled.	Use Computer Setup to check the storage security feature disabled settings.
	Diskette is damaged.	Replace the damaged disk.
Cannot format diskette.	Invalid media reported.	Check to see if diskette is bad.
		<p>When formatting a disk in MS-DOS, you might need to specify diskette capacity. For example, to format a 1.44-MB diskette, enter the following command at the command prompt:</p> <p><b>FORMAT A: /F:1440</b></p>
A problem has occurred with a disk transaction.	The directory structure is bad, or there is a problem with a file.	Right-click <b>Start</b> , click <b>Explore</b> , and select a drive. Select <b>File&gt;Properties&gt;Tools</b> . Under Error-checking, click <b>Check Now</b> .

**Table 6-5** Diskette problems (continued)

Problem	Cause	Solution
Diskette drive cannot read a diskette.	Diskette is not formatted.	Format the diskette.
	You are using the wrong diskette type for the drive type.	Be sure you use the correct diskette type for the type of drive you are using.
	You are reading the wrong drive.	Check the drive letter in the path statement.
	Diskette is damaged.	Replace the diskette with a new one.
<b>Invalid system disk</b> is displayed.	A diskette that does not contain the system files needed to start the workstation has been inserted in the drive.	When drive activity stops, remove the diskette and press the <b>spacebar</b> . The workstation should start up.
	Diskette error has occurred.	Restart the workstation by pressing the power button.
Cannot Boot from Diskette.	Diskette is not bootable.	Replace with a bootable diskette.
	Diskette boot has been disabled in Computer Setup.	Run Computer Setup and enable diskette boot in <b>Storage&gt;Boot Order</b> .
	Removable media boot has been disabled in Computer Setup.	Run Computer Setup and enable <b>Removable Media Boot</b> in <b>Storage&gt;Storage Options</b> .

## Solving hard drive problems

**Table 6-6** Hard drive problems

Problem	Cause	Solution
Hard drive error occurs.	Hard disk has bad sectors or has failed.	Use a disk analysis utility to locate and block usage of bad sectors. If necessary, reformat the hard disk.
Disk transaction problem.	Either the directory structure is bad or there is a problem with a file.	<ol style="list-style-type: none"> <li>1. Click on <b>My Computer</b>.</li> <li>2. Right-click on the desired hard drive and select <b>Properties</b>.</li> <li>3. Click the <b>Tools</b> tab.</li> <li>4. Click <b>Check Now...</b> to run error checking.</li> </ol>

**Table 6-6 Hard drive problems (continued)**

<b>Problem</b>	<b>Cause</b>	<b>Solution</b>
Drive not found (identified).	Loose cable.	Check cable connections.
	The system might not have automatically recognized a newly installed device.	<ol style="list-style-type: none"> <li>1. Run Computer Setup.</li> <li>2. If the system still does not recognize the new device, determine if the device is listed within Computer Setup. If it is listed, the probable cause is a driver problem. If it is not listed, the probable cause is a hardware problem.</li> <li>3. If this is a newly installed drive, enter <b>Setup</b> and try adding a POST delay under <b>Advanced&gt;Power-On&gt;Options</b>.</li> </ol>
	Drive's SATA controller is disabled in Computer Setup.	Run Computer Setup and enable the SATA controllers in <b>Storage&gt;Storage Options</b> .
	Drive responds slowly immediately after power on.	Run Computer Setup, and increase the POST Delay in <b>Advanced&gt;Power-On Options</b> .
Non-system disk/NTLDR missing message.	System is trying to start from a non-bootable diskette.	Remove the diskette from the diskette drive so the workstation boots from the hard disk.
Non-system disk/NTLDR missing message.	System is trying to start from a damaged hard drive.	<ul style="list-style-type: none"> <li>• Insert a bootable diskette into the diskette drive or a CD into the optical drive and restart the workstation.</li> </ul>
	System files missing or not properly installed.	<ol style="list-style-type: none"> <li>1. Insert a bootable system diskette and restart.</li> <li>2. Verify that the hard drive is partitioned and formatted.</li> <li>3. Install system files for the appropriate operating system if necessary.</li> </ol>
	Hard drive boot disabled in Computer Setup.	Run Computer Setup and enable the hard drive entry from <b>Storage Options</b> , then reorder the hard drive in the <b>Storage&gt;Boot Order</b> list.
	Both slow and fast UATA devices are on the same data cable.	Connect slower UATA devices to a separate data cable connected to the secondary IDE (ATA) controller.
Workstation will not start.	Hard drive is damaged.	Observe the beeps and LED lights on the front of the workstation. See <a href="#">POST error messages on page 160</a> .

## Solving display problems

**Table 6-7** Display problems

Problem	Cause	Solution
Blank screen (no video).	The cable connections are not correct.	Check the cable connections from the monitor to the workstation and to a working electrical outlet.
	The monitor is off.	Switch the monitor to on (LED is on). You might need to refer to the monitor manual for an explanation of the LED signals.
	Screen blanking utility installed or energy saver features enabled.	Press any key or click the mouse button and, if set, enter your password.
	System ROM is bad; system is running in FailSafe Boot Block mode (indicated by eight blinks/beeps).	Reflash the ROM using a ROMPaq diskette or a CD.
	Fixed-sync monitor will not sync at the resolution chosen.	Be sure that the monitor can accept the same horizontal scan rate as the resolution chosen.
	Computer is in Standby mode and the system LED is flashing	Press the power button to resume from mode. <b>CAUTION:</b> When attempting to resume from Standby mode, do not hold down the power button for more than four seconds. Otherwise, the workstation will shut down and you will lose your data.
	Monitor settings in the workstation are not compatible with the monitor.	<ol style="list-style-type: none"> <li>1. Restart the workstation and press <b>F8</b> during startup when you see <b>Press F8</b> in the bottom-right corner of the screen.</li> <li>2. Using the keyboard arrow keys, select <b>Enable VGA Mode</b> and press <b>Enter</b>.</li> <li>3. In Windows Control Panel, double-click the <b>Display</b> icon and click the <b>Settings</b> tab.</li> <li>4. Use the sliding control to reset the resolution.</li> <li>5. Refer to your operating system and graphics card documentation for information on changing display settings.</li> </ol>

**Table 6-7 Display problems (continued)**

Problem	Cause	Solution
The display works properly during the POST but goes blank when the OS starts.	The display settings in the operating system are incompatible with your graphics card and monitor.	<ol style="list-style-type: none"> <li>1. Restart the workstation and press <b>F8</b> during startup when you see <b>Press F8</b> in the bottom-right corner of the screen.</li> <li>2. Using the keyboard arrow keys, select <b>Enable VGA Mode</b> and press <b>Enter</b>.</li> <li>3. In Windows Control Panel, double-click the <b>Display</b> icon and click the <b>Settings</b> tab.</li> <li>4. Use the available functions to set the display to the proper values.</li> <li>5. Refer to your operating system and graphics card documentation for information on changing display settings.</li> </ol>
Power LED flashes red six times, once every second, followed by a two second pause, and the workstation beeps six times.	Pre-video graphics error.	<p><b>CAUTION:</b> Disconnect AC power from the workstation before reseating or replacing components because there is power to the system board even when the workstation is powered down.</p> <ol style="list-style-type: none"> <li>1. Ensure that the auxiliary power cable (if applicable) is securely connected.</li> <li>2. Reseat the graphics card.</li> <li>3. Replace the graphics card.</li> <li>4. Replace the system board.</li> </ol>
Monitor does not function properly when used with energy saver features.	Monitor without energy saver capabilities is being used with energy saver features enabled.	Disable monitor energy saver feature.
Characters are dim.	The brightness and contrast controls are not set properly.	Adjust the monitor brightness and contrast controls.
	Cables are not properly connected.	Verify that the graphics cable is securely connected to the graphics card and the monitor.
Video is blurry or requested resolution cannot be set.	If the graphics controller was upgraded, the correct video drivers might not be loaded.	Install the video drivers included in the upgrade kit.
	Monitor is not capable of displaying requested resolution.	Change requested resolution.



**Table 6-7 Display problems (continued)**

<b>Problem</b>	<b>Cause</b>	<b>Solution</b>
The picture is broken up, rolls, jitters, or flashes.	The monitor connections might be incomplete or the monitor might be incorrectly adjusted.	<ol style="list-style-type: none"> <li>1. Be sure the monitor cable is securely connected to the workstation.</li> <li>2. In a two-monitor system or if another monitor is in close proximity, be sure the monitors are not interfering with each other's electromagnetic field by moving them apart.</li> <li>3. Be sure that fluorescent lights or fans are not too close to the monitor.</li> </ol>
	Monitor needs to be degaussed.	Degauss the monitor.
Vibrating or rattling noise coming from inside a CRT monitor when powered on.	Monitor degaussing coil has been activated.	None. It is normal for the degaussing coil to be activated when the monitor is powered on.
Clicking noise coming from inside a CRT monitor.	Electronic relays have been activated inside the monitor.	None. It is normal for some monitors to make a clicking noise when turned on and off, when going in and out of Standby mode, and when changing resolutions.
High pitched noise coming from inside a flat panel monitor.	Brightness and contrast settings are too high.	Lower brightness and contrast settings.
Fuzzy focus; streaking, ghosting, or shadowing effects; horizontal scrolling lines; faint vertical bars; or unable to center the picture on the screen. (Flat panel monitors using an analog VGA input connection only.)	Flat panel monitor's internal digital conversion circuits might be unable to correctly interpret the output synchronization of the graphics card.	<ol style="list-style-type: none"> <li>1. Select the monitor's Auto-Adjustment option in the monitor's on-screen display menu.</li> <li>2. See the HP Support website and check for an updated display driver.</li> <li>3. Manually synchronize the Clock and Clock Phase on-screen display functions. Download the appropriate utility from the HP website to assist with the synchronization.</li> </ol>
Certain typed symbols do not appear correct.	The font you are using does not support that particular symbol.	Use the Character Map to locate the and select the appropriate symbol. Click <b>Start&gt;All Programs&gt; Accessories&gt;System Tools&gt;Character Map</b> . You can copy the symbol from the Character Map into a document.

## Solving audio problems

**Table 6-8** Audio problems

Problem	Cause	Solution
Sound does not come out of the speaker or headphones.	Software volume control is turned down.	Double-click the <b>Speaker</b> icon on the taskbar and use the volume slider to adjust the volume.
	The external speakers are not turned on.	Turn on the external speakers.
	External speakers are plugged into the wrong audio jack.	See the sound card documentation for proper speaker connection.
	Audio cable not connected.	Connect audio cable between CD or DVD-ROM drive and the system board.
	Digital CD audio is not enabled.	Enable digital CD audio: <ol style="list-style-type: none"> <li>1. From the Control Panel, select <b>System</b>.</li> <li>2. On the Hardware tab, click <b>Device Manager</b>.</li> <li>3. Right-click the <b>CD/DVD</b> device and select <b>Properties</b>.</li> <li>4. On the Properties tab, be sure <b>Enable digital CD audio for this CD-ROM device</b> is selected.</li> </ol>
	Headphones or devices connected to the line-out connector mute the internal speaker.	Turn on and use headphones or external speakers, if connected, or disconnect headphones or external speakers.
	Volume is muted.	<ol style="list-style-type: none"> <li>1. From the Control Panel program, click <b>Sound, Speech and Audio Devices</b>, and then click <b>Sounds and Audio Devices</b>.</li> <li>2. Clear the <b>Mute</b> check box.</li> </ol>
Computer is in Standby mode and the system LED is flashing.	Press the power button to resume from Standby mode. <b>CAUTION:</b> When attempting to resume from Standby mode, do not hold down the power button for more than four seconds. Otherwise, the workstation will shut down and you will lose your data.	
Noise or no sound comes out of the speakers or headphones.	<ol style="list-style-type: none"> <li>1. If using digital speakers that have a stereo jack and want the system to auto-switch to digital, use a stereo-to-mono adapter to properly engage the auto-sense feature or use the multimedia device properties to manually switch the audio signal from analog to digital.</li> <li>2. If the headphones have a mono jack, use the multimedia device properties to switch the system to analog out.</li> </ol>	

**Table 6-8 Audio problems (continued)**

Problem	Cause	Solution
<p><b>NOTE:</b> If you set digital as the <b>Output Mode</b>, the internal speaker and external analog speakers will no longer output audio until you switch back to an auto-sense or analog mode.</p> <p>If you set analog as the <b>Output Mode</b>, external digital speakers will not function until you change the output mode back to an auto-sense or digital mode.</p>		
Sound cuts in and out.	Processor resources are being used by other open applications.	Shut down open processor-intensive applications.
Workstation appears to be locked up while recording audio.	The hard disk might be full.	<ol style="list-style-type: none"> <li>1. Before recording, be sure there is enough free space on the hard disk.</li> <li>2. Try recording the audio file in a compressed format.</li> </ol>

## Solving printer problems

**Table 6-9 Printer problems**

Problem	Cause	Solution
Printer does not print. Printer cable loose.	Printer is not turned on and online.	Turn the printer on and be sure it is online.
	The correct printer driver for the application are not installed.	<ol style="list-style-type: none"> <li>1. Install the correct printer driver for the application.</li> <li>2. Try printing using the DOS command: DIR C:\&gt; [printer port] where [printer port] is the address of the printer being used. If the printer works, reload the printer driver.</li> </ol>
	If you are on a network, you might not have made the connection to the printer.	Make the proper network connections to the printer.
	Printer might have failed.	Run printer self-test.
	Printer is out of ink/toner.	Replenish ink/toner.
Printer does not turn on.	Printer cable loose.	Check printer cable connection to non-networked, local printer.
	The cables might not be connected properly.	Reconnect all cables.
	Printer prints garbled information.	<p>The correct printer driver is not installed. Install the correct printer driver for the application.</p> <p>The cables might not be connected properly. Reconnect all cables.</p> <p>Printer memory might be overloaded. Reset the printer by turning it off for one minute, then turn it back on.</p>
Printer is offline.	The printer might be out of paper.	<ol style="list-style-type: none"> <li>1. Check the paper tray and refill it if it is empty.</li> <li>2. Select online.</li> </ol>

## Solving keyboard and mouse problems

**Table 6-10** Keyboard and mouse problems

Problem	Cause	Solution	
Keyboard commands and typing are not recognized by the workstation.	Keyboard connector is not properly connected.	<ol style="list-style-type: none"> <li>1. Power off the workstation.</li> <li>2. Reconnect the keyboard to the workstation and restart the workstation.</li> </ol>	
	Program in use has stopped responding to commands.	Shut down the workstation using the mouse and then restart the workstation.	
	Keyboard needs repairs.	Replace the keyboard.	
	Keyboard key is stuck down.	Remove any debris from the keyboard.	
	Workstation is in Standby mode and the system LED is flashing.	<p>Press the power button to resume from Standby mode.</p> <p><b>CAUTION:</b> When attempting to resume from Standby mode, do not hold down the power button for more than four seconds. Otherwise, the workstation will shut down and you will lose your data.</p>	
Cursor will not move using the arrow keys on the keypad.	The <b>Num Lock</b> key might be on.	Press the <b>Num Lock</b> key. The Num Lock light should not be on if you want to use the arrow keys. The <b>Num Lock</b> key can be disabled (or enabled) in Computer Setup.	
Mouse does not respond to movement or is too slow.	Mouse connector is not properly plugged into the back of the workstation.	<ol style="list-style-type: none"> <li>1. Shut down the workstation using the keyboard.</li> <li>2. Plug the mouse connector into the PS/2 or USB mouse connector in the workstation and restart the workstation.</li> </ol>	
	You need to increase mouse acceleration.	<ol style="list-style-type: none"> <li>1. In Windows, click <b>Start&gt;Control Panel</b> and double-click <b>Mouse</b>.</li> <li>2. Select the <b>Motion</b> tab and adjust the speed.</li> </ol>	
	Program in use has stopped responding to commands.	Shut down the workstation using the keyboard and then restart the workstation.	
	Mouse needs repairs.	Replace the mouse.	
	Workstation is in Standby mode and system LED is flashing.	<p>Press the power button to resume from Stand By mode.</p> <p><b>CAUTION:</b> When attempting to resume from Standby mode, do not hold down the power button for more than four seconds. Otherwise, the workstation will shut down and you will lose your data.</p>	
	Mouse will only move vertically or horizontally, or movement is jerky.	Mouse roller ball is dirty.	Remove roller ball cover from the bottom of the mouse and clean it.

## Solving front panel component problems

If you are experiencing problems with one of the front panel ports, you might be able to try your device in the corresponding port on the back side of the computer. If this does not fix the problem, or you must use the front panel ports, continue troubleshooting.

Some problems in this section are also discussed in other troubleshooting suggestions in this chapter.

**Table 6-11** Front panel component problems

Problem	Cause	Solution
If a USB device, headphone, or microphone is not recognized by the workstation.	It is not properly connected.	<ol style="list-style-type: none"><li>1. Power off the workstation.</li><li>2. Reconnect the device to the workstation and restart the workstation.</li></ol>
	The device does not have power.	If the USB device requires AC power, be sure one end is connected to the device and one end is connected to a live outlet.
	The correct device driver is not installed.	<ol style="list-style-type: none"><li>1. Install the correct driver for the device.</li><li>2. You might need to reboot the workstation.</li></ol>
	The cable from the device to the computer does not work.	<ol style="list-style-type: none"><li>1. If possible, replace the cable.</li><li>2. Restart the workstation.</li></ol>
	The device is not working.	<ol style="list-style-type: none"><li>1. Replace the device.</li><li>2. Restart the workstation.</li></ol>
If a USB, audio, and IEEE-1394 devices are not working.	The internal cables might not be connected to the system board or the PCI card.	<ol style="list-style-type: none"><li>1. Power off the workstation.</li><li>2. Connect the cables correctly.</li></ol>
A device in the IEEE-1394a port is not responsive.	Cables of new external device are loose or power cables are unplugged.	Be sure that all cables are properly and securely connected.
	The power switch on the device is not turned on.	Power off the workstation, and power on the external device, then turn on the workstation to integrate the device with the workstation system.

## Solving hardware installation problems

You might need to reconfigure the workstation when you add or remove hardware, such as an additional diskette drive. If you install a PnP (Plug 'n Play) device, Windows XP automatically recognizes the device and configure the workstation. If you install a non-PnP device, you must reconfigure the workstation after completing installation of the new hardware.

**Table 6-12 Hardware installation problems**

<b>Problem</b>	<b>Cause</b>	<b>Solution</b>
A new device is not recognized as part of the system.	Device is not seated or connected properly.	Be sure that the device is properly and securely connected and that pins in the connector are not bent.
	Cables of new external device are loose or power cables are unplugged.	Be sure that all cables are properly and securely connected and that pins in the cable or connector are not bent.
	Power switch of new external device is not turned on.	Power off the workstation, power on the external device, and power on the workstation to integrate the device with the workstation system.
	When the system advised you of changes to the configuration, you did not accept them.	Reboot the workstation, and follow the instructions for accepting the changes.
	A PnP board might not automatically configure when added if the default configuration conflicts with other devices.	Use the Device Manager to clear the automatic settings for the board and select a basic configuration that does not cause a resource conflict. You can also use Computer Setup to reconfigure or disable devices to resolve the resource conflict.
	Device hardware is not properly jumpered or otherwise configured.	Read the device-specific configuration information and check for incorrect settings or conflicts with other devices already installed in the system.
Workstation will not start.	Wrong memory modules were used in the upgrade or memory modules were installed in the wrong location.	<ol style="list-style-type: none"><li>1. Review workstation documentation to determine if you are using the correct memory modules and to verify the proper installation.</li><li>2. Observe the beeps and LED lights on the front of the workstation. Refer to <a href="#">POST error messages on page 160</a> to determine possible causes.</li></ol>
	PCI Express power cable might be plugged into the wrong power connector.	Ensure that the auxiliary PCI Express power cable is correctly connected to the PCI Express card.

**Table 6-12 Hardware installation problems (continued)**

Problem	Cause	Solution
Power LED flashes red five times, once every second, followed by a two second pause, and the workstation beeps five times.	Memory is installed incorrectly or is bad.	<p><b>CAUTION:</b> Disconnect AC power from the workstation before reseating or replacing components because there is power to the system board even when the workstation is powered down.</p> <ol style="list-style-type: none"> <li>1. Ensure DIMMs are loaded in the correct slots.</li> <li>2. Reseat DIMMs.</li> <li>3. Replace DIMMs one at a time to isolate the faulty module.</li> <li>4. Replace third-party memory with HP memory.</li> <li>5. Replace the system board.</li> </ol>
Power LED flashes red six times, once every second, followed by a two second pause, and the workstation beeps six times.	Video card is not seated properly or is bad, or system board is bad.	<p><b>CAUTION:</b> Disconnect AC power from the workstation before reseating or replacing components because there is power to the system board even when the workstation is powered down.</p> <ol style="list-style-type: none"> <li>1. Ensure that auxiliary power cable is connected correctly, if applicable.</li> <li>2. Reseat the graphics card.</li> <li>3. Replace the graphics card.</li> <li>4. Replace the system board.</li> </ol>

## Solving network problems

These guidelines do not discuss the process of debugging the network cabling.

**Table 6-13 Network problems**

Problem	Cause	Solution
Wake-on-LAN feature is not functioning.	Wake-on-LAN is not enabled.	Use the Network control application to enable Wake-on-LAN.
Network driver does not detect network controller.	Network controller is disabled.	Run Computer Setup and enable network controller.
	Incorrect network driver.	Check the network controller documentation for the correct driver, or obtain the latest driver from the manufacturer's website.
Network status link light does not turn on or it never flashes.	No active network is detected.	Check cabling and network equipment for proper connection.
The network status light should flash when there is network activity.	Network controller is not set up properly.	Use the network control application to verify that the device is working properly.
	Network driver is not properly loaded.	Reinstall network drivers.
	System cannot auto-sense the network.	Disable auto-sensing capabilities and force the system into the correct operating mode.

**Table 6-13 Network problems (continued)**

<b>Problem</b>	<b>Cause</b>	<b>Solution</b>
Diagnostics reports a failure.	The cable is not securely connected.	Be sure that both ends of the data cable are securely connected.
	The cable is attached to the incorrect connector.	Be sure that the cable is attached to the correct connector.
	There is a problem with the cable or a device at the other end of the cable.	Be sure that the cable and device at the other end are operating correctly.
	Network controller interrupt is shared with an expansion board.	Under the Computer Setup <b>Advanced</b> menu, change the resource settings for the board.
	The network controller is defective.	<b>CAUTION:</b> Disconnect AC power from the workstation before reseating or replacing components because there is power to the system board even when the workstation is powered down. Replace the NIC.
Diagnostics passes, but the workstation does not communicate with the network.	Network drivers are not loaded, or driver parameters do not match current configuration.	<ol style="list-style-type: none"> <li>1. Be sure the network drivers are loaded and that the driver parameters match the configuration of the network controller.</li> <li>2. Be sure the correct network client and protocol is installed.</li> </ol>
	The network controller is not configured for this workstation.	Select the <b>Network</b> icon in the Control Panel and configure the network controller.
Network controller stopped working when an expansion board was added to the workstation.	Network controller interrupt is shared with an expansion board.	Under the Computer Setup <b>Advanced</b> menu, change the resource settings for the board.
	The network controller requires drivers.	Verify that the drivers were not accidentally deleted when the drivers for a new expansion board were installed.
	The expansion board installed is a Network Interface Card (NIC) and conflicts with the embedded NIC.	Under the Computer Setup <b>Advanced</b> menu, change the resource settings for the board.
Network controller stops working without apparent cause.	The files containing the network drivers are corrupted.	Reinstall the network drivers, using the <i>Restore Plus!</i> CD.
	The cable is not securely connected.	Be sure that both ends of the cable are securely attached to the correct devices.
	The network controller is defective.	<b>CAUTION:</b> Disconnect AC power from the workstation before reseating or replacing components because there is power to the system board even when the workstation is powered down. Replace the NIC.
New network card will not boot.	New network card might be defective or might not meet industry-standard specifications.	Install a working, industry-standard NIC, or change the boot sequence to boot from another source.



**Table 6-13 Network problems (continued)**

Problem	Cause	Solution
Cannot connect to network server when attempting Remote System Installation.	The network controller is not configured properly.	Verify Network Connectivity, that a DHCP Server is present, and that the Remote System Installation Server contains the NIC drivers for your NIC.
System setup utility reports unprogrammed EEPROM.	Unprogrammed EEPROM.	Flash the ROM.

## Solving memory problems

- △ **CAUTION:** For those systems that support ECC memory, HP does not support mixing ECC and non-ECC memory. Otherwise, the system will not boot the operating system.

**Table 6-14 Memory problems**

Problem	Cause	Solution
System will not boot or does not function properly after installing additional memory modules.	Memory module is not the correct type or speed, or the new memory module is not seated properly.	Replace module with the correct industry-standard device for the workstation.
Out of memory error.	Memory configuration might not be set up correctly.	Use the Device Manager to check memory configuration.
	You have run out of memory to run the application.	Check the application documentation to determine the memory requirements, or add more memory.
Memory count during POST is wrong.	The memory modules might not be installed correctly.	Check that the memory modules have been installed correctly and that proper modules are used.
Insufficient memory error during operation.	Too many Terminate and Stay Resident programs (TSRs) are installed.	Delete any TSRs that you do not need.
	You have run out of memory for the application.	Check the memory requirements for the application or add more memory to the workstation.

**Table 6-14** Memory problems (continued)

Problem	Cause	Solution
Power LED flashes red 5 times, once every second, followed by a 2-second pause, and the workstation beeps 5 times.	Memory is installed incorrectly or is bad.	<p><b>CAUTION:</b> Disconnect AC power from the workstation before reseating or replacing components because there is power to the system board even when the workstation is powered down.</p> <ol style="list-style-type: none"> <li>1. Ensure DIMMs are loaded in the correct slots.</li> <li>2. Reseat DIMMs.</li> <li>3. Replace DIMMs one at a time to isolate the faulty module.</li> <li>4. Replace third-party memory with HP memory.</li> <li>5. Replace the system board.</li> </ol>
A total of 4 GB of RAM is installed, yet the 32-bit OS only recognizes 3 GB.	A 32-bit OS is limited by 4 GB of address space, and some of the space is used by I/O devices.	Use a video card that uses less on-board memory.

## Solving processor problems

**Table 6-15** Processor problems

Problem	Cause	Solution
Poor performance is experienced.	Processor is hot.	<ol style="list-style-type: none"> <li>1. Be sure the airflow to the workstation is not blocked.</li> <li>2. Be sure the fans are connected and working properly (some fans only operate when needed).</li> <li>3. Be sure the CPU heatsink is installed properly.</li> </ol>
Power LED is red and stays on.	Processor is not seated properly or not installed.	<p><b>CAUTION:</b> Disconnect AC power from the workstation before reseating or replacing components because there is power to the system board even when the workstation is powered down.</p> <ol style="list-style-type: none"> <li>1. Check to see that the processor is present.</li> <li>2. Reseat the processor.</li> </ol>

## Solving CD-ROM and DVD problems

**Table 6-16** CD-ROM and DVD problems

Problem	Cause	Solution
System will not boot from CD-ROM or DVD drive.	The CD-ROM or DVD boot is not enabled through the Computer Setup utility.	Run the Computer Setup utility and enable booting to removable media and verify boot order settings.
	Non-bootable CD/DVD in drive.	Place a bootable CD/DVD in the drive.
CD-ROM or DVD devices are not detected or driver is not loaded.	Drive is not connected properly or not properly configured.	<ol style="list-style-type: none"> <li>1. Reconnect power and data cables to the drive.</li> <li>2. Install correct device driver.</li> </ol>
Movie will not play in the DVD drive.	Movie might be regionalized for a different country.	See the documentation that came with the DVD drive.
	Decoder software is not installed.	Install decoder software.
Cannot eject compact disc (tray-load unit).	Disc not properly seated in the drive.	<ol style="list-style-type: none"> <li>1. Power off the workstation, and insert a thin metal rod into the emergency eject hole and push firmly.</li> <li>2. Slowly pull the tray out from the drive until the tray is fully extended, and remove the disc.</li> </ol>
CD-ROM, CD-RW, DVD-ROM, or DVD-R/RW drive cannot read a disc or takes too long to start.	Disc has been inserted upside down.	Reinsert the disc with the label facing up.
	The DVD-ROM drive takes longer to start because it has to determine the type of media played, such as audio or video.	Wait at least 30 seconds to let the DVD-ROM drive determine the type of media being played. If the disc still does not start, read the other solutions listed for this topic.
	CD or DVD disc is dirty.	Clean CD or DVD with a CD cleaning kit.
	Windows does not detect the CD-ROM or DVD-ROM drive.	<ol style="list-style-type: none"> <li>1. Use Device Manager to remove or uninstall the device in question.</li> <li>2. Restart the workstation and allow Windows to detect the device.</li> </ol>
Recording audio CDs is difficult or impossible.	Wrong or poor quality media type.	<ol style="list-style-type: none"> <li>1. Try using a slower recording speed.</li> <li>2. Verify that you are using the correct media for the drive.</li> <li>3. Try a different brand of media. Quality varies widely between manufacturers.</li> </ol>

## Solving Internet access problems

Table 6-17 Internet access problems

Problem	Cause	Solution
Unable to connect to the Internet.	Internet Service Provider (ISP) account is not set up properly.	Verify Internet settings or contact the ISP for assistance.
	Modem is not set up properly.	Reconnect the modem. Verify the connections are correct using the quick setup documentation.
	Web browser is not set up properly.	Verify that the web browser is installed and set up to work with your ISP.
	Cable/ DSL modem is not plugged in.	Plug in cable/DSL modem. You should see a "power" LED light on the front of the cable/DSL modem.
	The network cable is disconnected.	Connect the network cable between the cable modem and the workstation RJ-45 connector. If the connection works, the PC LED light on the front of the cable/DSL modem will be on.
	Cable/DSL service is not available or has been interrupted due to bad weather.	Try connecting to the Internet at a later time or contact your ISP. (If the cable/DSL service is connected, the "cable" LED light on the front of the cable/DSL modem will be on.)
	The CAT5 10/100/1000 cable is disconnected.	Connect the CAT5 10/100 cable between the cable modem and the workstations's RJ-45 connector. (If the connection is good, the "PC" LED light on the front of the cable/DSL modem will be on.)
	IP address is not configured properly.	Contact the ISP for the correct IP address.
	Cookies are corrupted.	<ol style="list-style-type: none"><li>1. Select <b>Start&gt;Control Panel</b>.</li><li>2. Double-click <b>Internet Options</b>.</li><li>3. On the General tab, click <b>Delete Cookies</b>.</li></ol>

**Table 6-17 Internet access problems (continued)**

<b>Problem</b>	<b>Cause</b>	<b>Solution</b>
Cannot automatically launch Internet programs.	You must log on to the ISP before some programs will start.	Log on to the ISP and launch the desired program.
Internet takes too long to download websites.	Modem is not set up properly.	Verify that the correct modem speed and COM port are selected. <ol style="list-style-type: none"><li>1. Select <b>Start&gt;Control Panel</b>.</li><li>2. Double-click <b>System</b>.</li><li>3. Click the <b>Hardware</b> tab.</li><li>4. In the Device Manager area, click <b>Device Manager</b>.</li><li>5. Double-click <b>Ports</b> (COM &amp; LPT).</li><li>6. Right-click the COM port your modem uses, then click <b>Properties</b>.</li><li>7. Under Device status, verify that the modem is working properly.</li><li>8. Under Device usage, verify the modem is enabled.</li><li>9. If there are further problems, click <b>Troubleshoot</b> and follow the on-screen instructions.</li></ol>

## POST error messages

POST is a program run at startup that initializes and runs some tests on installed hardware. An audible and/or visual message occurs if the POST encounters a problem. POST checks the following items to ensure that the workstation system is functioning properly:

- Keyboard
- Memory modules
- Diskette drives
- All SATA, IDE, and SAS mass storage devices
- Processors
- Controllers

 **NOTE:** If the Power-On Password is set, a key icon appears on the screen while POST is running. You must enter the password before continuing.

**Table 6-18 POST error messages**

Screen Message	Probable Cause	Recommended Action
101–Option ROM Error.	Plug-in card ROM checksum.	Update the ROM on the card.
102–System Board Failure	DMA, timers.	<b>CAUTION:</b> Disconnect AC power from the workstation before reseating or replacing components because there is power to the system board even when the workstation is powered down. <ol style="list-style-type: none"><li>1. Clear CMOS by pressing the Clear CMOS button on the system board.</li><li>2. Remove expansion boards.</li><li>3. Replace the system board.</li></ol>
103–System Board Failure	DMA, timers.	<b>CAUTION:</b> Disconnect AC power from the workstation before reseating or replacing components because there is power to the system board even when the workstation is powered down. <ol style="list-style-type: none"><li>1. Clear CMOS by pressing the Clear CMOS button on the system board.</li><li>2. Remove expansion boards.</li><li>3. Replace the system board.</li></ol>
110–Out of Memory Space for Option ROMs	Option ROM for a device was unable to run due to memory constraints.	Remove expansion boards and disable unneeded devices from <b>I/O&gt;Onboard Devices</b> or <b>Storage&gt;Storage Options</b> . Run Computer Setup (F10).
162–System Options Not Set	Your system configuration has changed since your last boot, in which case press <b>F1</b> . Or, a loss of power to the Real Time clock has occurred.	<ol style="list-style-type: none"><li>1. Run Computer Setup (F10).</li><li>2. Set the date and time under Windows Control Panel or in the F10 Setup menu.</li><li>3. If the problem persists, replace the RTC battery.</li></ol>

**Table 6-18 POST error messages (continued)**

Screen Message	Probable Cause	Recommended Action
163–Time and Date Not Set	Invalid time or date in configuration memory. RTC (real-time clock) battery might need to be replaced.	<ol style="list-style-type: none"><li>1. Set the date and time under Control Panel or in F10 Setup, depending on the operating system.</li><li>2. If the problem persists, replace the RTC battery.</li></ol>
164–Memory Size Error	The system memory size has changed since the last boot.	<ol style="list-style-type: none"><li>1. Pressing <b>F1</b> will record the configuration.</li><li>2. If the problem persists, be sure memory modules (if any) are installed correctly.</li><li>3. If third-party memory has been added, test using HP memory only.</li><li>4. Verify proper memory module type.</li></ol>
201–Memory Error	The memory test performed during startup failed.	<p><b>CAUTION:</b> Disconnect AC power from the workstation before reseating or replacing components because there is power to the system board even when the workstation is powered down.</p> <ol style="list-style-type: none"><li>1. Run Computer Setup (F10 Setup) or Windows utilities.</li><li>2. Ensure that memory modules are installed correctly.</li><li>3. Verify proper memory module type.</li><li>4. If third-party memory has been added, test using HP memory only.</li><li>5. Remove and replace memory modules one at a time to isolate faulty module.</li><li>6. Replace the faulty memory modules.</li><li>7. If error persists after replacing memory modules, replace the system board.</li></ol>
207–ECC Corrected Single Bit Errors in DIMM slot(s)	Corrected ECC error(s) detected.	<p><b>CAUTION:</b> Disconnect AC power from the workstation before reseating or replacing components because there is power to the system board even when the workstation is powered down.</p> <ol style="list-style-type: none"><li>1. Verify proper memory module type.</li><li>2. Verify 3rd party/HP memory.</li><li>3. Try another memory socket.</li><li>4. Replace memory module if problem persists.</li></ol>

**Table 6-18 POST error messages (continued)**

Screen Message	Probable Cause	Recommended Action
211–Memory warning condition detected	An unknown issue with one of the DIMMs has been detected.	<p><b>CAUTION:</b> Disconnect AC power from the workstation before reseating or replacing components because there is power to the system board even when the workstation is powered down.</p> <ol style="list-style-type: none"> <li>1. Verify proper memory module type.</li> <li>2. Try another memory socket.</li> <li>3. Replace memory module if problem persists.</li> </ol>
213–Incompatible ECC Memory Module in memory Socket(s)	The memory modules in the system are either not all ECC, or not all non-ECC. This could also be caused because the DIMM is missing critical SPD information.	<p><b>CAUTION:</b> Disconnect AC power from the workstation before reseating or replacing components because there is power to the system board even when the workstation is powered down.</p> <ol style="list-style-type: none"> <li>1. Verify that all memory modules are ECC or non-ECC.</li> <li>2. Replace memory module if problem persists.</li> </ol>
214–DIMM Configuration Warning	DIMMs not installed correctly (not paired correctly).	<p><b>CAUTION:</b> Disconnect AC power from the workstation before reseating or replacing components because there is power to the system board even when the workstation is powered down.</p> <p>Refer to <a href="#">Memory on page 72</a> for the correct memory configurations and reseat the DIMMs accordingly.</p>
215–Cannot Interleave Unequal Memory Nodes	Memory node interleave enabled but memory on CPU0 is unequal with the memory on CPU1.	<p><b>CAUTION:</b> Disconnect AC power from the workstation before reseating or replacing components because there is power to the system board even when the workstation is powered down.</p> <ol style="list-style-type: none"> <li>1. Reconfigure memory in both nodes equally.</li> <li>2. Disable memory node interleave.</li> </ol>
301–Keyboard Error	Keyboard failure.	<ol style="list-style-type: none"> <li>1. Reconnect keyboard with workstation powered off.</li> <li>2. Check the connector for bent or missing pins.</li> <li>3. Be sure that none of the keys are pressed or stuck.</li> <li>4. Replace keyboard.</li> </ol>
303–Keyboard Controller Error	I/O board keyboard controller.	<p><b>CAUTION:</b> Disconnect AC power from the workstation before reseating or replacing components because there is power to the system board even when the workstation is powered down.</p> <ol style="list-style-type: none"> <li>1. Reconnect keyboard with workstation powered off.</li> <li>2. Replace the system board.</li> </ol>



**Table 6-18 POST error messages (continued)**

Screen Message	Probable Cause	Recommended Action
304—Keyboard or System Unit Error	Keyboard failure.	<b>CAUTION:</b> Disconnect AC power from the workstation before reseating or replacing components because there is power to the system board even when the workstation is powered down. <ol style="list-style-type: none"><li>1. Reconnect the keyboard to the powered-off workstation.</li><li>2. Be sure that none of the keys are pressed or stuck.</li><li>3. Replace keyboard.</li><li>4. Replace system board.</li></ol>
510—Splash Screen Image Corrupted	Splash Screen image has errors.	Restore BIOS.
511—CPU Fan Not Detected	Fan is not connected or it might have malfunctioned.	<ol style="list-style-type: none"><li>1. Reseat fan cable.</li><li>2. Reseat the fan.</li><li>3. Replace the fan.</li></ol>
512—PCI 1 Fan Not Detected	Fan is not connected or it might have malfunctioned.	<b>CAUTION:</b> Disconnect AC power from the workstation before reseating or replacing components because there is power to the system board even when the workstation is powered down. <ol style="list-style-type: none"><li>1. Reseat PCI fan cable.</li><li>2. Replace PC1 fan.</li></ol>
513—Chassis Fan or Memory Fan Not Detected	Memory or system fan is not connected or it might have malfunctioned.	<b>CAUTION:</b> Disconnect AC power from the workstation before reseating or replacing components because there is power to the system board even when the workstation is powered down. <ol style="list-style-type: none"><li>1. Reseat memory or system fan connector.</li><li>2. Replace memory or system fan.</li></ol>
514—VRD fan not detected	VRD fan on liquid cooling unit not functioning.	Verify VRD fan operation; replace if necessary.
516—Processors Do Not Have the Same Frequency Operating Range	Installed processors operate at different frequencies.	Replace a processor so that both operate at the same frequency.
516—Processors Do Not Have the Same Frequency Operating Range	Installed processors operate at different frequencies.	Replace a processor so that both operate at the same frequency.

**Table 6-18 POST error messages (continued)**

Screen Message	Probable Cause	Recommended Action
517–Front IEEE 1394 Not Connected	Front IEEE 1394 port is not connected.	<b>CAUTION:</b> Disconnect AC power from the workstation before reseating or replacing components because there is power to the system board even when the workstation is powered down. <ol style="list-style-type: none"><li>1. Connect IEEE 1394 cable to system board.</li><li>2. Replace system board.</li></ol>
518–Detected invalid MAC address	Workstation has invalid MAC address.	<b>CAUTION:</b> Disconnect AC power from the workstation before reseating or replacing components because there is power to the system board even when the workstation is powered down. <ul style="list-style-type: none"><li>• Verify correct MAC address. If incorrect, replace system board.</li></ul>
601–Diskette Controller Error	Diskette controller circuitry or diskette drive circuitry incorrect.	<b>CAUTION:</b> Disconnect AC power from the workstation before reseating or replacing components because there is power to the system board even when the workstation is powered down. <ol style="list-style-type: none"><li>1. Run Computer Setup (F10 Setup).</li><li>2. Ensure that cables are connected correctly.</li><li>3. Check and replace cables.</li><li>4. Clear CMOS by pressing the Clear CMOS button on the system board.</li><li>5. Replace diskette drive.</li><li>6. Replace the system board.</li></ol>
605–Diskette Drive Type Error	Mismatch in drive type.	<ol style="list-style-type: none"><li>1. Check drive cables.</li><li>2. Run Computer Setup (F10 Setup).</li><li>3. Disconnect any other diskette controller devices (tape drives).</li><li>4. Clear CMOS by pressing the Clear CMOS button on the system board.</li><li>5. Replace diskette drive.</li></ol>
710–NET Watchdog Timer Expired from Last Boot	System hung during last boot.	Press <b>F1</b> to boot.
912–Computer Cover Has Been Removed Since Last System Start Up	System has been opened since last boot.	No action required.
914–Hood Lock Coil is not Connected	Hood lock mechanism is missing or not connected.	<ol style="list-style-type: none"><li>1. Reconnect or replace the hood locking mechanism.</li><li>2. Reseat or replace the hood locking mechanism cable.</li></ol>

**Table 6-18 POST error messages (continued)**

Screen Message	Probable Cause	Recommended Action
915–Fan Power from Power Supply Not Connected	The fan power cable is not connected, or the power supply is bad.	<b>CAUTION:</b> Disconnect AC power from the workstation before reseating or replacing components because there is power to the system board even when the workstation is powered down. <ol style="list-style-type: none"><li>1. Verify that all power supply cables are connected.</li><li>2. Replace the power supply.</li></ol>
916–Power Button Not Connected	The power button is not connected.	<b>CAUTION:</b> Disconnect AC power from the workstation before reseating or replacing components because there is power to the system board even when the workstation is powered down. Connect the power button.
917–Front Audio Not Connected	The front audio cable is not connected.	<b>CAUTION:</b> Disconnect AC power from the workstation before reseating or replacing components because there is power to the system board even when the workstation is powered down. Connect the front audio cable.
918–Front USB Not Connected	Front USB is not connected.	<b>CAUTION:</b> Disconnect AC power from the workstation before reseating or replacing components because there is power to the system board even when the workstation is powered down. Connect the front USB cable.
921–Device in PCI Express Slot Failed to Initialize	A PCI Express card was detected in one of the slots, but failed to initialize properly.	<b>CAUTION:</b> Disconnect AC power from the workstation before reseating or replacing components because there is power to the system board even when the workstation is powered down. Reseat all PCI Express cards. If this failure occurred after inserting a new card, there could be a problem with that card.
922–Fatal error on slot #	Fatal error occurred in the designated slot.	<b>CAUTION:</b> Disconnect AC power from the workstation before reseating or replacing components because there is power to the system board even when the workstation is powered down. Try moving card to a different slot. If the problem persists, try replacing the card.
923–Non fatal error on slot #	A PCI or PCIe non-fatal error condition occurred for the device in the designated slot.	<b>CAUTION:</b> Disconnect AC power from the workstation before reseating or replacing components because there is power to the system board even when the workstation is powered down. <ol style="list-style-type: none"><li>1. Reseat the card.</li><li>2. Try moving card to a different slot.</li><li>3. If the problem persists, replace the card.</li></ol>

**Table 6-18 POST error messages (continued)**

Screen Message	Probable Cause	Recommended Action
1155–Serial Port Address Conflict Detected.	Both external and internal serial ports are assigned to same IRQ.	<ol style="list-style-type: none"> <li>1. Remove any COM port expansion cards.</li> <li>2. Clear CMOS by pressing the Clear CMOS button on the system board.</li> <li>3. Reconfigure card resources and run Computer Setup (F10 Setup).</li> <li>4. Run Computer Setup or Windows utilities.</li> </ol>
1201–System Audio Address Conflict Detected	Device IRQ address conflicts with another device. (Usually due to an add-in audio card.)	Reset the IRQ.
1720 SMART Hard Drive Detect Imminent Failure	Hard drive is about to fail. (Some hard drives have a firmware patch that will fix an erroneous error message.)	<p><b>CAUTION:</b> Disconnect AC power from the workstation before reseating or replacing components because there is power to the system board even when the workstation is powered down.</p> <ol style="list-style-type: none"> <li>1. Determine if hard drive is giving correct error message.</li> <li>2. Run the Drive Protection System test if applicable.</li> <li>3. Apply firmware patch if applicable (see <a href="http://www.hp.com/support">http://www.hp.com/support</a>).</li> <li>4. Back up contents and replace hard drive.</li> </ol>
1800–Temperature Alert	Internal temperature exceeds specification.	<p><b>CAUTION:</b> Disconnect AC power from the workstation before reseating or replacing components because there is power to the system board even when the workstation is powered down.</p> <ol style="list-style-type: none"> <li>1. Check that workstation air vents are not blocked and that the cooling fan is running.</li> <li>2. Verify processor speed selection.</li> <li>3. Replace the processor.</li> <li>4. Replace the system board.</li> </ol>
1801–Microcode Update Error	Missing or Invalid Processor Microcode Update.	Upgrade BIOS to the current version.
1802–CPU0 Not Supported	The system board does not support the processor.	<p><b>CAUTION:</b> Disconnect AC power from the workstation before reseating or replacing components because there is power to the system board even when the workstation is powered down.</p> <p>Replace the processor with a compatible one.</p>

**Table 6-18** POST error messages (continued)

Screen Message	Probable Cause	Recommended Action
1803—CPU1 Not Supported	The system board does not support the processor.	<b>CAUTION:</b> Disconnect AC power from the workstation before reseating or replacing components because there is power to the system board even when the workstation is powered down.  Replace the processor with a compatible one.
1805—CPU Bypass Board is Missing	Bypass board not detected on single-processor system.	<b>CAUTION:</b> Disconnect AC power from the workstation before reseating or replacing components because there is power to the system board even when the workstation is powered down.  Install bypass board or install second processor.
Invalid Electronic Serial Number	Electronic serial number has become corrupted.	<ul style="list-style-type: none"><li>• Run Computer Setup. Enter the serial number under <b>Security&gt;System IDs</b>, and save the changes.</li></ul>

---

# A Appendix A — SAS devices

## Supported SAS RAID configurations

The following RAID configurations are supported on the HP xw9400 Workstation.

 **NOTE:** This section does not apply to configuring RAID in the Linux environment. For RAID in the Linux environment, configure SW RAID configurations as provided by Red Hat Enterprise Linux.

- Up to 5 internal or 8 external SAS hard disk drives/JBOD.
- External connections require optional internal-to-external cable
- SAS drives require SATA to SAS data and power converter
- LSI MyStorage Utility for Windows
- RAID 0 (IS) – Striped disk array
  - Two drives minimum
  - Improved I/O performance
  - No fault tolerance
- RAID 1 (IM) — Mirrored disk array
  - Two drives
  - Improved read performance
  - 100% redundancy
  - Can recover from single drive failure
- RAID 1E (IME)
  - Three drives minimum
  - Can be an odd number of drives
  - Can always recover from a single drive failure, and in some cases, recover from two drive failures

## SAS RAID 0 (IS) configuration

Follow the steps below to configure an Integrated Striped (IS) volume with the BIOS-based configuration utility. The configuration procedure assumes that the system already has the required disks attached to the SAS/SATA ports.

1. At the BIOS splash screen, press any key to view option ROM messages.
2. Press **Ctrl-C** at the prompt **Press Ctrl-C to Start LSI Logic Configuration Utility** to start the utility.
3. On the Adapter List screen of the LSI Logic Config Utility, use the arrow keys to highlight an adapter (SAS1068e), then press **Enter**.

4. On the Adapter Properties screen use the arrow keys to highlight **RAID Properties**, then press **Enter**.
  5. In the Select New Array Type-SAS1068e screen, use the arrow keys to highlight **Create IS Volume**, then press **Enter**.
  6. In the Create New Array-SAS1068e screen, use the arrow keys to select the first disk for the Create IS volume. Then use the arrow keys to move to the Raid Disk column for this disk, and press the **SPACE**, **+**, or **-** key to select **Yes** as the value for this column. If there is existing data on the disk, a message displays warning you that data on the disk is lost when the striped volume is created. Press the **M** key to migrate, or the **D** key to delete the data on the drive.
- 
-  **NOTE:** An xw9400 chassis supports up to 5 internal hard disk drives. Using external cables, up to three additional drives can be connected via individual external drives for a total of eight drives. Up to 128 devices can be supported via connection to a JBOD.
- 
7. Repeat the previous step to select up to four more disks for the striped volume.
  8. Press the **C** key to create the array once all drives have been chosen.
  9. Use the arrow keys to select **Save Changes then Exit this Menu**, then press **Enter**.
  10. Press **Esc-Esc**. Use the arrow keys to highlight **Exit the Configuration Utility and Reboot**, then press **Enter**.
  11. If necessary, change the boot order in system BIOS to obtain the correct boot device.

## SAS RAID 1 (IM) configuration

Follow the steps below to configure an Integrated Mirroring (IM) volume with the BIOS-based configuration utility. The configuration procedure assumes that the system already has the required disks attached to the SAS/SATA ports.

1. At the BIOS splash screen, press any key to view option ROM messages.
2. Press **Ctrl-C** at the **Press Ctrl-C to Start LSI Logic Configuration Utility** prompt to enter the configuration utility.
3. On the Adapter List screen of the LSI Logic Config Utility, use the arrow keys to highlight an adapter (SAS1068e), then press **Enter**.
4. On the Adapter Properties-SAS1068e screen use the arrow keys to highlight **RAID Properties**, then press **Enter**.
5. On the Select New Array Type screen, use the arrow keys to highlight the **Create Volume IM** volume, then press **Enter**.
6. In the Create New Array-SAS1068e screen, use the arrow keys to select the primary disk for the IM volume (the disk with the data you want to mirror.) Use the arrow keys to move to the Raid Disk column for this disk and use the **Space**, **+**, or **-** key to select **Yes** as the value. If there is existing data on the disk, a message appears warning you that data on the disk is lost when the disk is used in an IM array.

Press the **M** key to keep the existing data and migrate to an IM array. Synchronization of the disk occurs. Press the **D** key to overwrite the existing data and create a new IM array. No synchronization is performed.

---

 **CAUTION:** All data on all disks in the array is deleted if **D** is selected.

---

After selecting **M** or **D**, the Drive Status changes to **Primary** for the initial drive selected.

7. Use the arrow keys to select the secondary (mirrored) disk for the IM volume. Use the [SPACE](#), [+](#), or [-](#) key to select **Yes** as the value for the Array Disk column. When the second drive selected in RAID Disk is set to **Yes**, Drive Status changes to **Secondary**.
  - [Optional] Use the arrow keys to select a hot spare disk for the IM volume. Use [SPACE](#), [+](#), or [-](#) to select **Yes** as the value in the Hot Spr column.
8. When you have completed selection of drives and hot spares for the IM array, press **C** to create the array.
9. Use the arrow keys to select **Save Changes then Exit this Menu**, then press [Enter](#).
10. Press [Esc-Esc](#). Use the arrow keys to highlight **Exit the Configuration Utility and Reboot**, and press [Enter](#).
11. If necessary, change the boot order in system BIOS to obtain the correct boot device.

## SAS RAID 1E (IME) configuration

Follow the steps below to configure an Integrated Mirroring Extended (IME) volume with the BIOS-based configuration utility. The configuration procedure assumes that the system already has the required disks attached to the SAS/SATA ports.

1. At the BIOS splash screen, press any key to view option ROM messages.
2. Press [Ctrl-C](#) at the **Press Ctrl-C to Start LSI Logic Configuration Utility** prompt to enter the configuration utility.
3. On the Adapter List screen of the LSI Logic Config Utility, use the arrow keys to highlight an adapter (SAS1068e), then press [Enter](#).
4. On the Adapter Properties-SAS1068e screen use the arrow keys to select **RAID Properties**, then press [Enter](#).
5. On the Select New Array Type-SAS1068e screen, use the arrow keys to highlight **Create IME Volume**, then press [Enter](#).
  - In the Create New Array-SAS1068e screen, use the arrow keys to select the first disk for the IME volume. Use the arrow keys to move to the RAID Disk column for this disk, and use the [SPACE](#), [+](#), or [-](#) key to select **Yes** as the value.
6. Use the arrow keys to select the next disk for the IME volume. Use the [SPACE](#), [+](#), or [-](#) key to select **Yes** as the value for the RAID Disk column.
7. Repeat the previous steps to select up to four more disks for the IME volume. If you want to configure a hot spare disk for the volume, you can only select up to three more disks.
  - [Optional] Use the arrow keys to select a Hotspare disk for the IME volume. Use [SPACE](#), [+](#), and [-](#) to select **Yes** as the value in the Hot Spr column.
8. When you have completed selection of the drives and hot spares for the IME array, press **C** to create the array.
9. Use the arrow keys to highlight **Save Changes Then Exit this Menu**, and press [Enter](#).
10. Press [Esc-Esc](#). Use the arrow keys to highlight **Exit the Configuration Utility and Reboot**, and press [Enter](#).
11. If necessary, change the boot order in system BIOS to obtain the correct boot device.



## Changing boot order

If the RAID array will be a data array, the disk drive with the operating system must appear higher in the boot order. If the RAID array will be the operating system drive, it should appear higher in the boot order.

To change the boot order:

1. Press **F10** to call up the BIOS Setup utility when booting the system.
2. If first boot, select the desired language and press **Enter**. English is the default.
3. Use the arrow keys to highlight **Storage>Boot Order**, and press **Enter**.
4. In the Hard Drive section device names are listed in order of boot. Use the arrow keys to move the cursor to the device that you want to move. Press **Enter** to highlight the device.
5. Use the up/down arrow keys to move the device to the desired order location. Press **Enter** to un-highlight the device.
6. Press **F10** to save changes.
7. Use the arrow keys to highlight **File>Save Changes and Exit**. Press **Enter**, then **F10**.

---

## B Appendix B—SATA devices

This appendix describes how to use the NVIDIA MediaShield utility to set up and manage SATA RAID volumes.

The SATA RAID option must be enabled in BIOS and the SATA drives must be attached to the workstation ports to configure them into a RAID array.

Attach the required number of SATA HDDs for the desired RAID level:

- RAID 0—two to six HDDs—data is striped across drives for performance
- RAID 1—two HDDs—data is mirrored on two drives for security
- RAID 5—three to six HDDs—data is striped across drives with parity for performance with security
- RAID 10—four to six HDDs—data is mirrored and striped across all drives for security and some performance

### Enable SATA RAID option in BIOS

To enable the SATA RAID option in BIOS:

1. During boot up, press **F10** to enter the Setup menu. **Entering BIOS Setup (Press F10)** appears at the bottom of the screen.
2. If first boot, select the desired language and press **Enter**.
3. Use the arrow keys to highlight **I/O>Device Options** and press **Enter**.
4. Use the up/down arrow keys to place the cursor next to **SATA RAID**. Use the left/right arrow keys to change the State to **Enable**.

 **NOTE:** All six ports (0–5) then indicate they are enabled. If the operating system boot drive is a non-RAID SATA drive, this port should have RAID disabled.

5. Use the up/down arrow keys to place the cursor next to the ports that are **not** to be included in the RAID array. Use the left/right arrow keys to change the state of each of them to **Disable**.
6. Press **F10** when all ports have been set to the desired state.
7. Use the arrow keys to highlight **File>Save Changes and Exit**. Press **Enter**, then press **F10** to save changes.

The workstation will reboot after the changes are saved. After the workstation reboots, the BIOS displays the MediaShield copyright message.

### Configuring a SATA RAID array

To configure a SATA RAID array:

1. At the BIOS splash screen, press any key to view option ROM messages.
2. Press **F6** to enter the RAID setup utility when **Press F6 to enter RAID setup utility** is displayed.

3. On the Define a New Array screen, **RAID Mode** is highlighted in blue and mirroring is set as the default setting. Press **Enter** to show the RAID modes. This mode enables control of mirroring, striping, stripe mirroring, spanning, and RAID 5.
4. Use the up/down arrow keys to highlight in red the desired RAID type, then press **Enter**. **The desired RAID mode will be highlighted in blue.**
5. Press the **Tab** key to move the blue highlight to **Striping Block**.
6. Use the up/down arrow keys to highlight in red the desired striping block size (4K, 8K, 16K 32K, 64K, 128K or Optimal). Press **Enter** to select the desired size.

---

 **NOTE:** Optimal is the default and is generally selected. It is determined by the RAID controller for best fit.

---
7. Press the **Tab** key to move the blue highlight to the **Free Disks** section.

---

 **NOTE:** All drives available for RAID are listed and the first drive is highlighted in red.

---
8. Use the up/down arrow keys to highlight in red the drives to be included in the RAID array.
9. Use the right arrow key to move the drive to the **Array Disks** section.

---

 **NOTE:** The left arrow key moves the red highlighted drive in the Array Disks section to the Free Disks section.

---
10. Press **F7** to finish when all desired drives selected for the array are in the Array Disks section.
11. To clear disk data press **Y**, or to save disk data in the array press **N**.  
The Array List window appears showing the created array. It contains Status, Bootable, Vendor, and Array Model Name information.
12. Press **Ctrl-X** to exit the utility.

## Changing boot order

If the RAID array will be a data array, the disk drive with the operating system must appear higher in the boot order. If the RAID array will be the operating system drive, it should appear higher in the boot order.

To change the boot order:

1. Press **F10** to call up the BIOS Setup utility when booting the system.
2. If first boot, select the desired language and press **Enter**. English is the default.
3. Use the arrow keys to highlight **Storage>Boot Order**, and press **Enter**.
4. In the Hard Drive section device names are listed in order of boot. Use the arrow keys to move the cursor to the device that you want to move. Press **Enter** to highlight the device.
5. Use the up/down arrow keys to move the device to the desired order location. Press **Enter** to un-highlight the device.
6. Press **F10** to save changes.
7. Use the arrow keys to highlight **File>Save Changes and Exit**. Press **Enter**, then **F10**.

## Deleting RAID volumes

Use the NVIDIA MediaShield utility to delete RAID volumes.

1. Press **F6** to enter the RAID setup utility when **Press F6 to enter RAID setup utility** is displayed. The MediaShield Utility displays the array list. One of the arrays listed is highlighted in red.
2. Use the up/down arrow keys to highlight RAID volume to be deleted.
3. Press **Enter** to enter the array details. The Array Details screen shows the array details. Press **D** to delete, then **Y** to confirm the delete.

The screen then returns to either Array List or Define a New Array.

# C Appendix C— Connector pins

## Connector pin descriptions

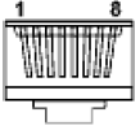
Ethernet connector	Pin	Signal
	1	(+) Transmit Data
	2	(-) Transmit Data
	3	(+) Receive Data
	4	(-) Receive Data
		Unused
	5	Unused
	6	Unused
	7	Unused
8	Unused	

Serial connector	Pin	Signal
	1	Carrier Detect
	2	Receive Data
	3	Transmit Data
	4	Data Terminal Ready Signal
	5	Ground
	6	Data Set Ready
	7	Request to Send
	8	Clear to Send
	9	Ring Indicator

USB connector	Pin	Signal
	1	+5 VDC
	2	- Data
	3	+ Data
	4	GND

IEEE 1394 connector	Pin	Signal
	1	power
	2	gnd
	3	tpb-
	4	tpb+
	5	tpa-
	6	tpa+

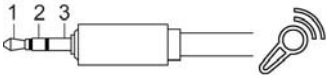
Microphone connector (1/8 inch)	Pin	Signal
	1 (Tip)	Audio
	2 (Ring)	Power
	3 (Shield)	Ground

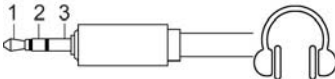
Headphone connector (1/8 inch)	Pin	Signal
	1 (Tip)	Audio_Left
	2 (Ring)	Audio_Right
	3 (Shield)	Ground

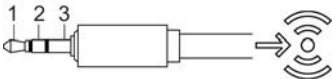
Line-in audio connector (1/8 inch)	Pin	Signal
	1 (Tip)	Audio_In_Left
	2 (Ring)	Audio_In_Right
	3 (Shield)	Ground

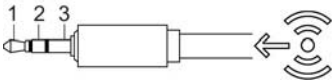
Line-out audio connector (1/8 inch)	Pin	Signal
	1 (Tip)	Audio_Out_Left
	2 (Ring)	Audio_Out_Right
	3 (Shield)	Ground

SPDIF OUT connector	Pin	Signal
	1	+VDC
	2	Ground

SPDIF OUT internal header	Pin	Signal
	1	+VDC
	2	Ground

 **NOTE:** The SPDIF Out internal header is used in parallel with the SPDIF OUT connector. Only one should be used at a time.

### SATA connector

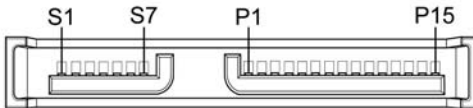

Pin	Signal	Pin	Signal	Pin	Signal
<b>Data Cable</b>		<b>Power Cable</b>		<b>Power Cable</b>	
S-1	Ground	P-1	3.3-V power	P-8	5-V power
S-2*	A+	P-2	3.3-V power	P-9	5-V power
S-3*	A-	P-3	3.3-V power	P-10	Ground
S-4	Ground	P-4	Ground	P-11	Reserved
S-5**	B-	P-5	Ground	P-12	Ground
S-6**	B+	P-6	Ground	P-13	12-V power
S-7	Ground	P-7	5-V power	P-14	12-V power
				P-15	12-V power

\* S2 and S3 differential signal pair

\*\*S5 and S6 differential signal pair

## SAS connector

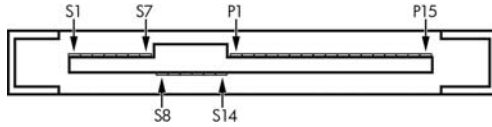

Segment	Pin	Backplane receptacle	Plug and cable receptacles
Primary signal segment	S1	SIGNAL GROUND	
	S2	TP+	RP+
	S3	TP-	RP-
	S4	SIGNAL GROUND	
	S5	RP-	TP-
	S6	RP+	TP+
	S7	SIGNAL GROUND	
Secondary signal segment	S8	SIGNAL GROUND	
	S9	TS+	RS+
	S10	TS-	RS-
	S11	SIGNAL GROUND	
	S12	RS-	TS-
	S13	RS+	TS+
Power segment	S14	SIGNAL GROUND	
	P1	$V_{33}^c$	
	P2	$V_{33}^c$	
	P3	$V_{33}^c$ precharge <sup>c</sup>	
	P4	GROUND	
	P5	GROUND	
	P6	GROUND	
	P7	$V_5^c$ precharge <sup>c</sup>	
	P8	$V_5^c$	
	P9	$V_5^c$	
	P10	GROUND	
	P11	READY LED <sup>d</sup>	
	P12	GROUND	
	P13	$V_{12}$ precharge <sup>c</sup>	
	P14	$V_{12}^c$	
P15	$V_{12}^c$		



## VGA connector

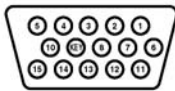

Pin	Signal	Pin	Signal	Pin	Signal
1	Red Analog	6	GND	11	Monitor ID
2	Green Analog	7	GND	12	DDC Serial Data
3	Blue Analog	8	GND	13	Horizontal Sync
4	Monitor ID	9	+5V DC	14	Vertical Sync
5	GND	10	GND	15	DDC Serial Clock

## DVI connector

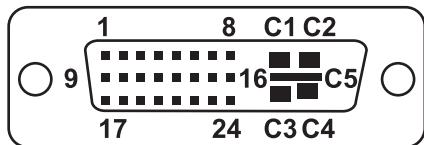

Pin	Signal	Pin	Signal
1	T.M.D.S DATA 2-	16	HOT PLUG DETECT
2	T.M.D.S DATA 2+	17	T.M.D.S DATA 0-
3	T.M.D.S DATA 2/4 SHIELD	18	T.M.D.S DATA 0+
4	T.M.D.S DATA 4-	19	T.M.D.S DATA 0/5 SHIELD
5	T.M.D.S DATA 4+ 2	0	T.M.D.S DATA 5-
6	DDC CLOCK	21	T.M.D.S DATA 5+
7	DDC DATA	22	T.M.D.S CLOCK SHIELD
8	ANALOG VERT. SYNC	23	T.M.D.S CLOCK+
9	T.M.D.S DATA 1-	24	T.M.D.S CLOCK-
10	T.M.D.S DATA 1+		
11	T.M.D.S DATA 1/3 SHIELD	C1	ANALOG RED
12	T.M.D.S DATA 3-	C2	ANALOG GREEN
13	T.M.D.S DATA 3+	C3	ANALOG BLUE
14	+5V POWER	C4	ANALOG HORZ SYNC
15	GND	C5	ANALOG GROUND

### ATA/ATAPI (IDE) standard drive cable connector

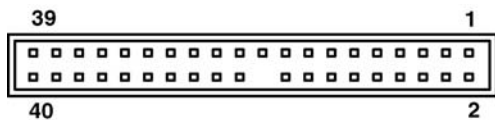

Pin	Signal	Pin	Signal	Pin	Signal
1	Reset	15	DD1	29	DMAK
2	GND	16	DD14	30	GND
3	DD7	17	DD0	31	INTRQ
4	DD8	18	DD15	32	IOCS16
5	DD6	19	GND	33	DA1
6	DD9	20	(Key)	34	PDIAG (cable detect)
7	DD5	21	DMAR Q	35	DA0
8	DD10	22	GND	36	DA2
9	DD4	23	DIOW	37	CS1FX
10	DD11	24	GND	38	CS3FX
11	DD3	25	DIOR	39	DASP
12	D12	26	GND	40	GND
13	D2	27	IORD Y		
14	D13	28	CSEL		

### 24-Pin Main power connector

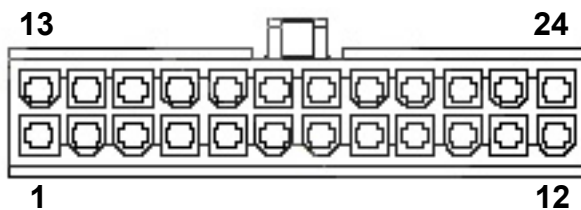

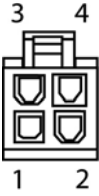

1	+3.3 V	8	POK	14	-12 V	21	+5 V
2	+3.3 V	9	+5 Vaux	15	GND	22	+5 V/+5 V- Rsense
3	GND	10	+12V-B	16	PS_ON _L	23	+5 V
4	+5 V	11	+12V-B	17	GND	24	GND
5	GND	12	+3.3 V	18	GND		
6	+5 V	13	+3.3 V/+3.3 V- Rsense	19	GND		
7	GND			20	GND		

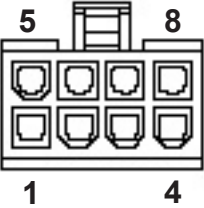
4-Pin power (memory system board) connector	Pin	Color	Signal
	1	BLK	GND
	2	BLK	GND
	3	BLK w/YEL stripe	+12V-M
	4	BLK w/YEL stripe	+12V-M

8-Pin power (for CPUs and onboard regulators) connector	Pin	Color	Signal
	1	BLK	GND
	2	BLK	GND
	3	BLK	GND
	4	BLK	GND
	5	Gray BLK w/WHT stripe	+12 V CPU0 Rsense +12 V CPU0
	6	BLK w/WHT stripe	+12V CPU0
	7	BLK w/light blue stripe	+12V CPU1
	8	BLK w/light blue stripe	+12V CPU1

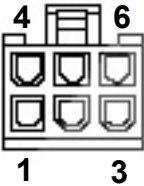
 **NOTE:** The 6-pin power (auxiliary PCI Express) is only required with high-powered graphics cards.

6-Pin power (auxiliary PCI Express)	Pin	Color	Signal
	1	BLK w/YEL stripe	+12V-G
	2	BLK w/YEL stripe	+12V-G
	3	BLK w/YEL stripe	+12V-G
	4	BLK	GND
	5	BLK	GND
	6	BLK	GND

Keyboard connector		Pin	Signal
	1	Data	
	2	Unused	
	3	Ground	
	4	+5 VDC	
	5	Clock	
	6	Unused	

Mouse connector		Pin	Signal
	1	Data	
	2	Unused	
	3	Ground	
	4	+5 VDC	
	5	Clock	
	6	Unused	

Internal Type A USB connector		Pin	Signal
	1	+5 VDC	
	2	- Data	
	3	+ Data	
	4	Ground	

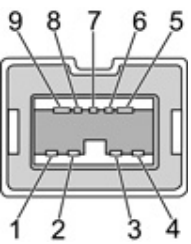
Internal IEEE 1394b connector		Pin	Signal
	1	TPB-	
	2	TPB+	
	3	TPA-	
	4	TPA+	
	5	TPA (R)	
	6	VG	
	7	SC	
	8	VP	
	9	TPB (R)	

# D Appendix D— System board designators

This appendix lists the system board designators for this system.

Designator	Silkscreen	Component
BAT1	BAT1	Battery retainer
E49	CLR PSWD	Clear password jumper
J9	None	Stacked RJ45/dual USB
J12	FRNT 1394	Front panel 1394a header
J14		SPDIF OUT connector
J15	None	Stacked RJ45/dual USB
J20	SLOT3 PCI32/33	PCI 32-bit slot
J25	SLOT6 PCI-X x100	PCI-X slot
J26	SLOT7 PCI-X x100/133	PCI-X slot
J31	SLOT1 PCI-E x8	PCIe x8 slot
J32	SLOT5 PCI-E x16	PCIe x16 slot
J33	SLOT4 PCI-E x8	PCIe x8 slot
J34	FRNT-P	Front panel connector
J41	SLOT2 PCI-E x16	PCI Express x16 slot for graphics
J68	None	Stacked keyboard/mouse connector
J83		Triple stacked audio jack
J84	1394/USB	IEEE 1394a/dual USB stacked connector
JP13	1-2 FORCE TO100 MHz 2-3 100/133 MHz (DEFAULT)	PCI-X bus speed select jumper*
JP16	HBA HDD LED ACTIVITY	HBA HDD LED activity header
JP30	FAN DET OVR	Fan detection override jumper
P1	PWR	Main power connector (24-pin)
P2	PWR2	Memory power connector (4-pin)
P3	PWRCPU	Processor power connector (8-pin)
P7	CD	CD analog audio connector
P8	CHASSIS FAN	Primary chassis fan header
P10	FLPY	Floppy connector

Designator	Silkscreen	Component
P11	AUX	Auxiliary audio connector
P19	SPDIF OUT	SPDIF OUT header
P20	PRIMARY IDE	Primary IDE connector
P23	FRNT AUD	Front panel audio header
P24	FRNTUSB2–3	Front panel USB header
P25	IUSB1	Internal USB header
P26	IUSB0	Internal USB header (Requires AMO kit with USB cable)
P54	None	Serial port connector
P60-63, P66-67	SATA0-SATA5	SATA Connectors
P70	CPUFAN0	CPU0 fan header
P71	CPUFAN1	CPU1 fan header
P80-87	SAS/SATA0–SAS/SATA7	SAS Connectors
P91	VOLTAGE REGULATOR FAN (LIQUID COOLING UNIT)	Voltage regulator fan connector
P92	PCI FAN	PCI fan header
P93	MEMORY FAN	Memory fan header
P94	12V FAN	12-V fan header
P95	12V FAN	12-V fan header
SW50	CMOS	Clear CMOS switch/push button
U15	ROM	ROM socket
XMM1	DIMM3b	Memory slot
XMM2	DIMM3a	Memory slot
XMM3	DIMM1b	Memory slot
XMM4	DIMM1a	Memory slot
XMM5	DIMM4b	Memory slot
XMM6	DIMM4a	Memory slot
XMM7	DIMM2b	Memory slot
XMM8	DIMM2a	Memory slot
XU1	CPU0	Primary processor socket
XU2	CPU1	Secondary processor socket

\* With the jumper on pins 1 and 2, the PCI-X bus speed is 100 MHz, regardless of the card configuration in slots 6 and 7. With the jumper on pins 2 and 3 (default), the following PCI-X bus speed/card configuration applies:

<b>Card configuration</b>	<b>Max PCI-X bus speed achieved*</b>
One card in slot 7 only	133 MHz
One card in slot 6 only	100 MHz
Two cards, one in each slot	100 MHz

\* Dependent upon card capability.

---

# E Appendix E— Power cord set requirements

The power cord set (flexible cord or wall plug) received with this product meets the requirements for use in the country where you purchased the equipment.

If you must obtain a power cord for a different country, purchase a power cord that is approved for use in that country.

The power cord must be rated for the product and for the voltage and current marked on the product's electrical ratings label. The voltage and current rating of the cord should be greater than the voltage and current rating marked on the product. The length of the cord must be between 1.8m (6 feet) and 3.6m (12 feet). If you have questions about the type of power cord to use, contact an HP authorized service provider.

Route the power cord so that it is not likely to be walked on or pinched by items placed on it or against it. Pay particular attention to the plug, electrical outlet, and the point where the cord exits from the product.

---

 **NOTE:** Use a 15 A-capable (minimum) power cord with a 110V power source. Use a 10 A-capable (minimum) power cord with a 220V power source.

---



---

# F Appendix F— Routine care

## General cleaning safety precautions

- Never use solvents or flammable solutions to clean the workstation.
- Never immerse any component in water or cleaning solutions; apply any liquids to a clean cloth and then use the cloth on the component.
- Always unplug the workstation before cleaning the keyboard, mouse, or air vents.
- Disconnect the keyboard before cleaning it.
- Wear safety glasses equipped with side shields when cleaning the keyboard.

## Maximizing the airflow

- Keep your workstation in an area where the airflow to the front and rear of the system is not obstructed.
- If possible, keep the unit off of surfaces where dust can gather.
- Keep the back of the unit at least 0.15m (6 in.) away from a wall or other obstruction.
- Keep the front of the unit clear of any obstruction that keeps air from entering the front of the system.
- Remove any dust on the front panel (vent area) and the rear fans with a small vacuum, compressed air, or dust rag.

## Cleaning the workstation case

- Follow the safety precautions presented in [Service considerations on page 51](#) before cleaning the workstation.
- To remove light stains or dirt, use plain water with a clean, lint-free cloth or swab.
- For stronger stains, use a mild dish-washing liquid diluted with water. Rinse well by wiping it with a cloth or swab dampened with clear water.
- For stubborn stains, use isopropyl (rubbing) alcohol. No rinsing is needed because the alcohol will evaporate quickly and not leave a residue.
- After cleaning, always wipe the unit with a clean, lint-free cloth.
- Occasionally clean the air vents on the workstation. Lint and other foreign matter can block the vents and limit the airflow.

## Cleaning the keyboard

△ **CAUTION:** Use safety glasses equipped with side shields before attempting to clean debris from under the keys.

---

- Follow the safety precautions presented in [Service considerations on page 51](#) before cleaning the keyboard.
- Visible debris underneath or between the keys can be removed by vacuuming or shaking.
- Canned, pressurized air can be used to clean debris from under the keys. Use caution because too much air pressure can dislodge lubricants applied under the wide keys.
- If you remove a key, use a specially designed key puller to prevent damage to the keys. This tool is available through many electronic supply outlets.

△ **CAUTION:** Never remove a wide leveled key (like the space bar) from the keyboard. If these keys are improperly removed or installed, the keyboard might not function properly.

---

- Clean under a key with a swab moistened with isopropyl alcohol and squeezed out. Be careful not to wipe away lubricants necessary for proper key functions. Allow the parts to air dry before reassembly.
- Use tweezers to remove any fibers or dirt in confined areas.

## Cleaning the monitor

- Follow the safety precautions presented in [Service considerations on page 51](#) before cleaning the monitor.
- To clean the monitor, wipe the monitor screen with a towelette designed for cleaning monitors or a clean cloth moistened with water.

△ **CAUTION:** Do not use sprays or aerosols directly on the screen—the liquid might seep into the housing and damage a component.

Never use solvents or flammable liquids on the monitor because display or housing damage may result.

---

## Cleaning the mouse

1. Follow the safety precautions presented in [Service considerations on page 51](#) before cleaning the mouse.
2. Remove the mouse ball from the housing by removing the retaining plate.
3. Clean the mouse ball.
4. Pull out any debris from the ball socket, and wipe the ball with a clean, dry cloth.
5. Reassemble the mouse.

---

# G Appendix G— Additional password security and resetting CMOS

This workstation supports the following security password features, which can be established through the Computer Setup Utility menu:

- Setup password
- Power-on password

If only a power-on password is established, it must be entered to boot the workstation.

If only a setup password is established, it must be entered to access the setup menu. Power cycling is required for the setup password to take effect.

If both passwords are set, either password can be entered to boot, but the setup password must still be entered to access the Computer Setup Utility menu.

If you forget the password for the computer, remove the Clear Password jumper on the system board.

## Resetting the password jumper

To disable the power-on or setup password features and clear the power-on and setup passwords:

1. Shut down the operating system, and power off the workstation and any external devices. Disconnect the power cord of the workstation and any external devices from the power outlets.
  - ⚠ **WARNING!** To reduce the risk of personal injury from electrical shock and hot surfaces, be sure to disconnect the power cord from the wall outlet and allow the internal system components to cool before touching.
  - ⚠ **CAUTION:** When the workstation is plugged in, the power supply always applies voltage to the system board—even when the unit is turned off. Failure to disconnect the power cord can result in damage to the system.
  - CAUTION:** Static electricity can damage the electronic components of the workstation or optional equipment. Before beginning these procedures, be sure that you are discharged of static electricity by briefly touching a grounded metal object.
2. Remove the access panel.
3. Locate the password header and jumper. The password header is E49. For assistance locating the password jumper and other system board components, refer to the service label on the workstation access panel.
4. Remove the jumper.
5. Replace the access panel.
6. Plug in and power on the workstation. Allow the operating system to start. This process clears the current passwords and disables the password features.
7. To establish new passwords, repeat steps 1 through 3, replace the password jumper on both pins 1 and 2, and repeat steps 5 through 6. Establish the new passwords in the Computer Setup Utility.

## Clearing and resetting the CMOS

The CMOS of the workstation stores password information and information about the workstation configuration. This section describes the steps to successfully clear and reset the CMOS.

### Using the CMOS button

1. Shut down the operating system, and power off the workstation and any external devices. Disconnect the power cord of the workstation and any external devices from the power outlets.

⚠ **WARNING!** To reduce the risk of personal injury from electrical shock and hot surfaces, be sure to disconnect the power cord from the wall outlet and allow the internal system components to cool before touching.

⚠ **CAUTION:** When the workstation is plugged in, the power supply always applies voltage to the system board—even when the unit is turned off. Failure to disconnect the power cord can result in damage to the system.

**CAUTION:** Static electricity can damage the electronic components of the workstation or optional equipment. Before beginning these procedures, be sure that you are discharged of static electricity by briefly touching a grounded metal object.

2. Remove the access panel.
3. Locate and press the clear CMOS button.

⚠ **CAUTION:** Pushing the clear CMOS button resets CMOS values to factory defaults and erases some customized information. It is important to back up the workstation CMOS settings before resetting them in case they are needed later. To back up the CMOS settings, use the Replicated Setup option in the Computer Setup Utility menu.

For assistance locating the clear CMOS button and other system board components, refer to the service label on the workstation access panel.

📄 **NOTE:** AC power does not need to be disconnected for the clear CMOS button to work.

The clear CMOS button does not clear the workstation passwords.

4. Replace the access panel.
5. Plug in and power on the workstation.

📄 **NOTE:** Any special configurations will have to be reset.

### Using the Computer Setup Utility to reset CMOS

To reset CMOS to factory defaults:

1. Enter the Computer Setup Utility menu by pressing **F10** when the **F10=Setup** prompt displays on the screen during bootup. The word **Setup** displays in the lower right corner of the screen. If a setup password has been set, a password prompt displays on the screen.

📄 **NOTE:** If you do not press the F10 key while the message is displayed, the workstation must be powered off, then on again, to access the utility.

2. Select **File>Default Setup>Restore Factory Settings as Default**, and press **F10**. Press any key at the prompt that then displays.

📄 **NOTE:** This procedure does not reset the date and time.

3. Select **File>Apply Defaults and Exit**. Press **F10** at the prompt that then displays.

---

# H Appendix H— Quick troubleshooting flowcharts

This appendix presents some quick troubleshooting flowcharts for the following issues:

- Initial troubleshooting
- No power
- No video
- Error messages
- No OS loading
- No OS loading from hard drive
- No OS loading from diskette drive
- No OS loading from optical drive
- No OS loading from network
- Non-functioning device

---

 **NOTE:** The flowcharts presented are for general troubleshooting purposes only and they might not apply to your specific workstation.

---

## Initial troubleshooting

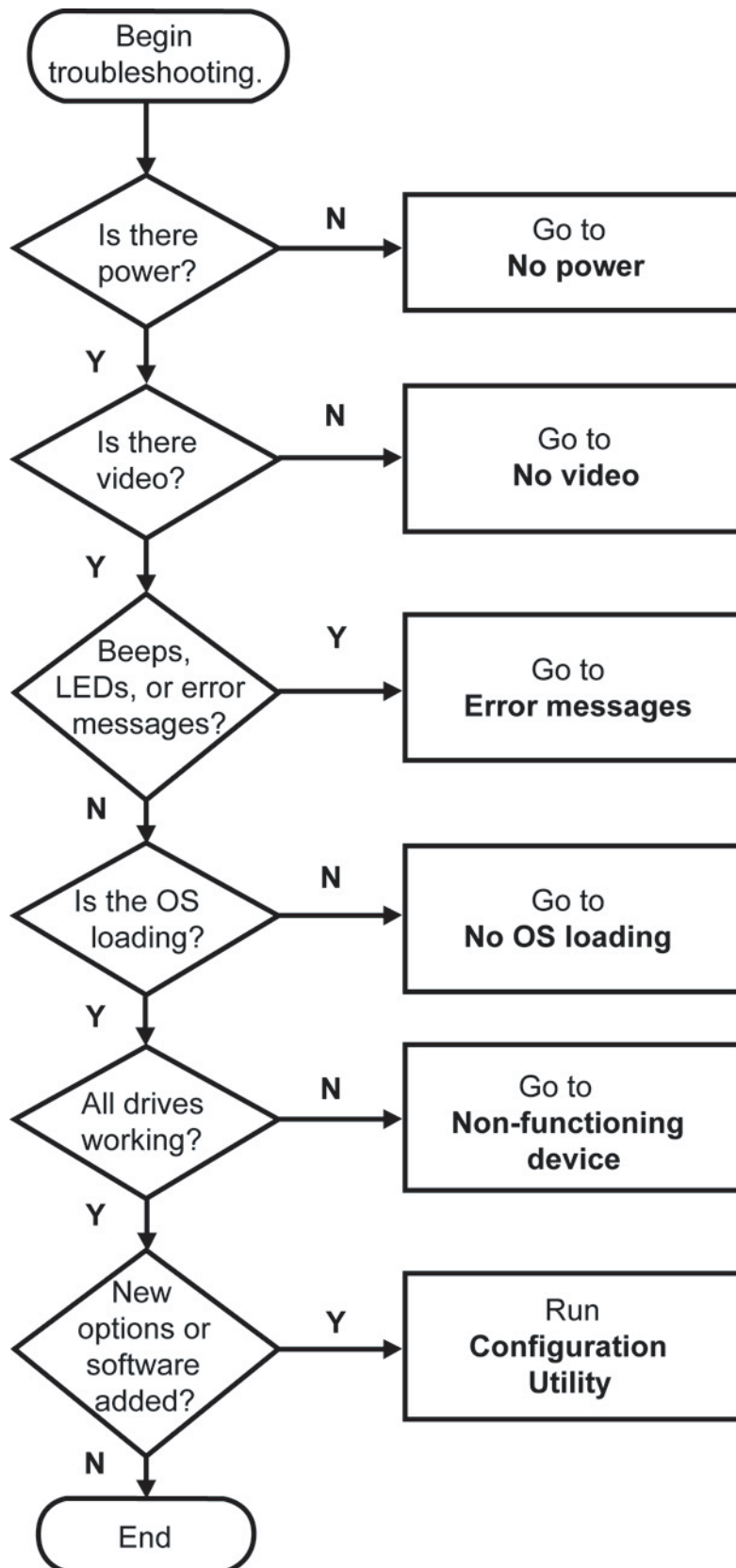

# No power

## No power, part 1

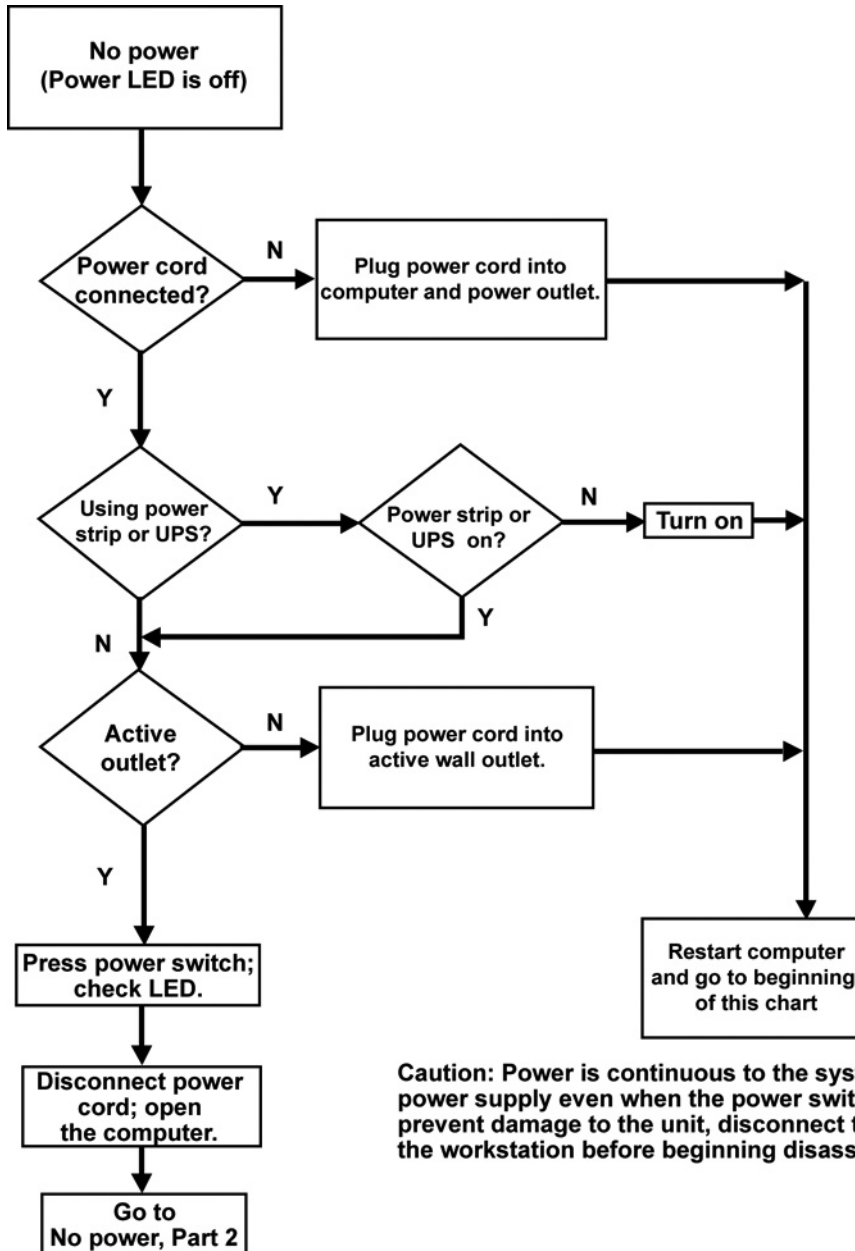

**Caution:** Power is continuous to the system board and power supply even when the power switch is off. To prevent damage to the unit, disconnect the power cord from the workstation before beginning disassembly procedure.

## No power, part 2

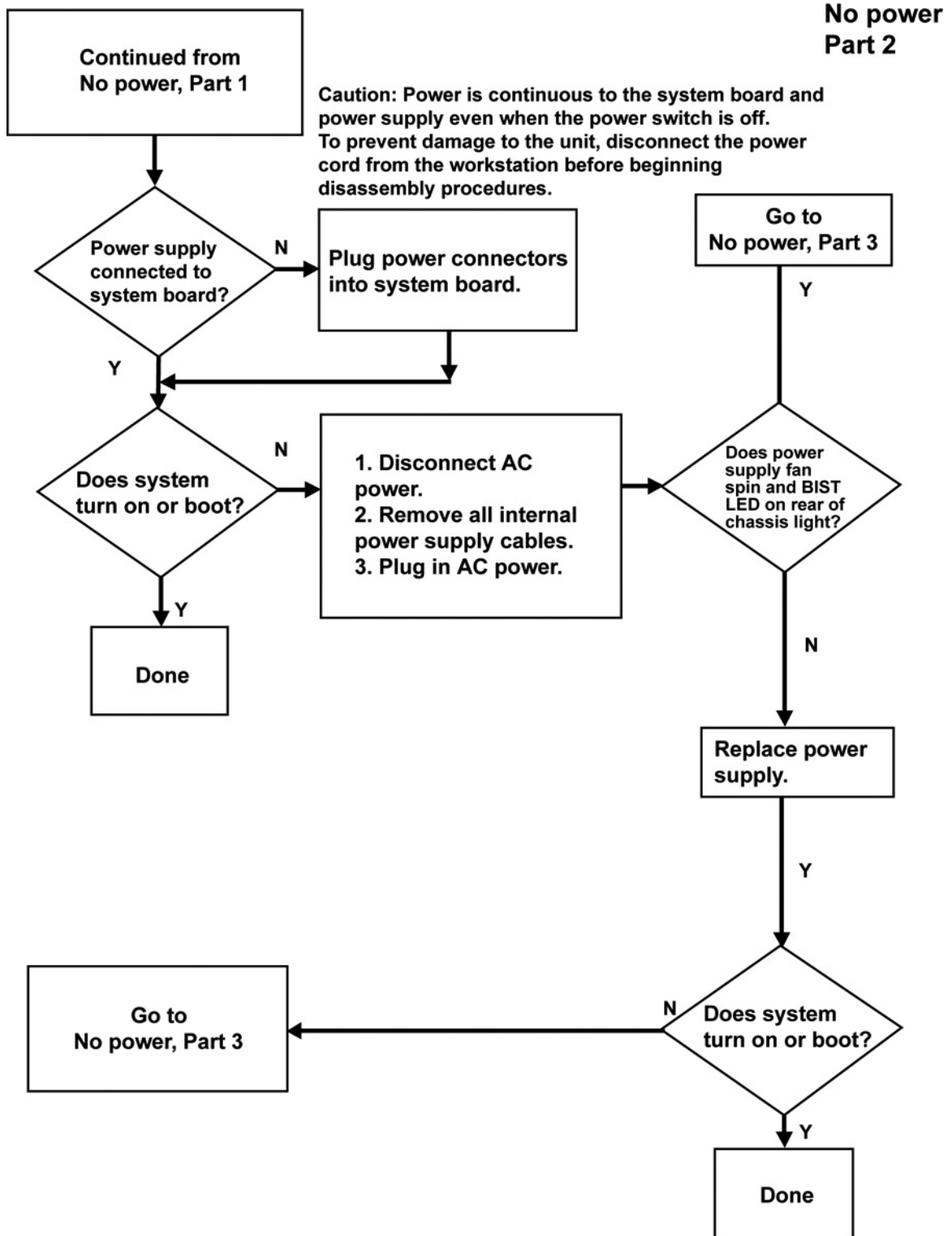



### No power, part 3

### No power Part 3

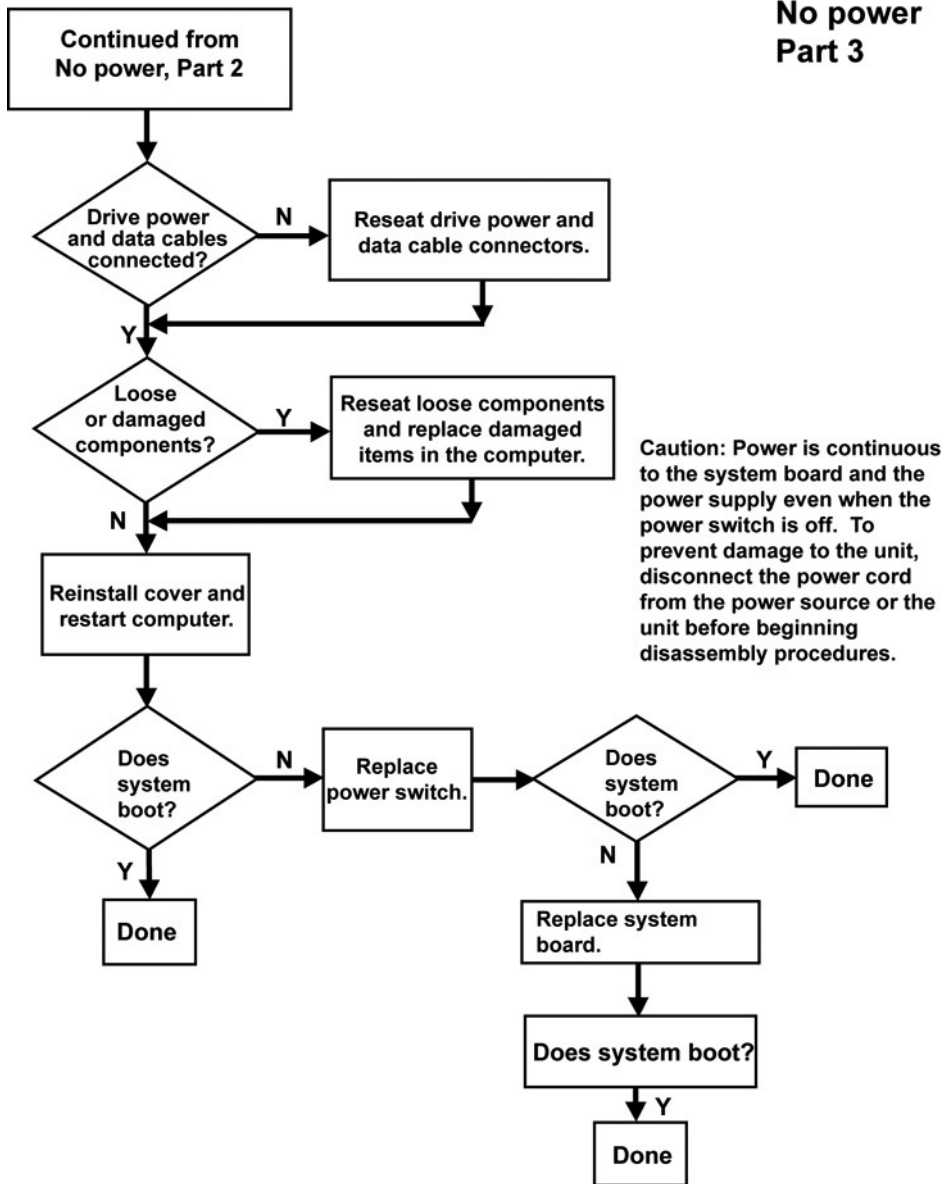

# No video

## No video, part 1

### No video Part 1

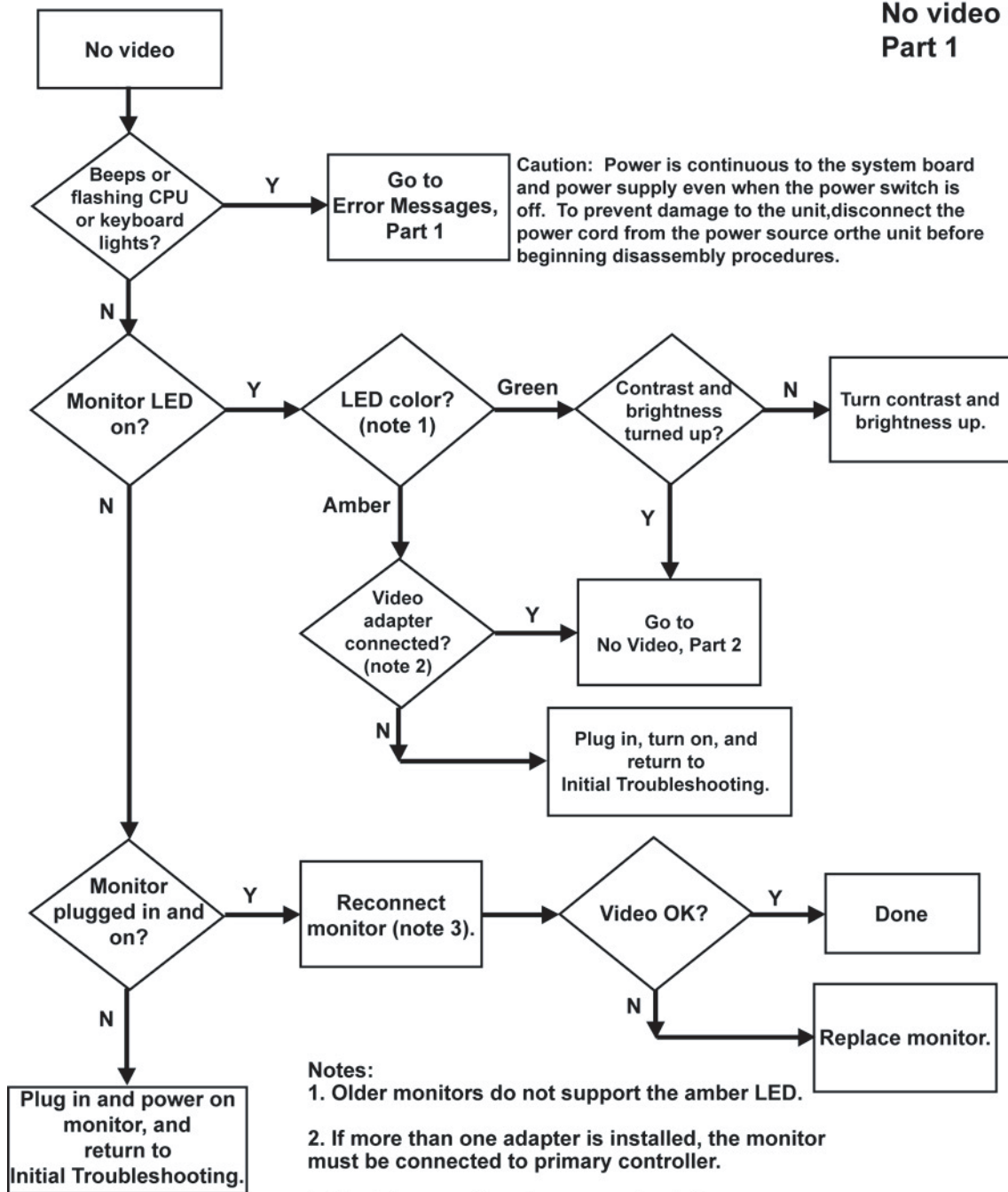

## No video, part 2

## No video Part 2

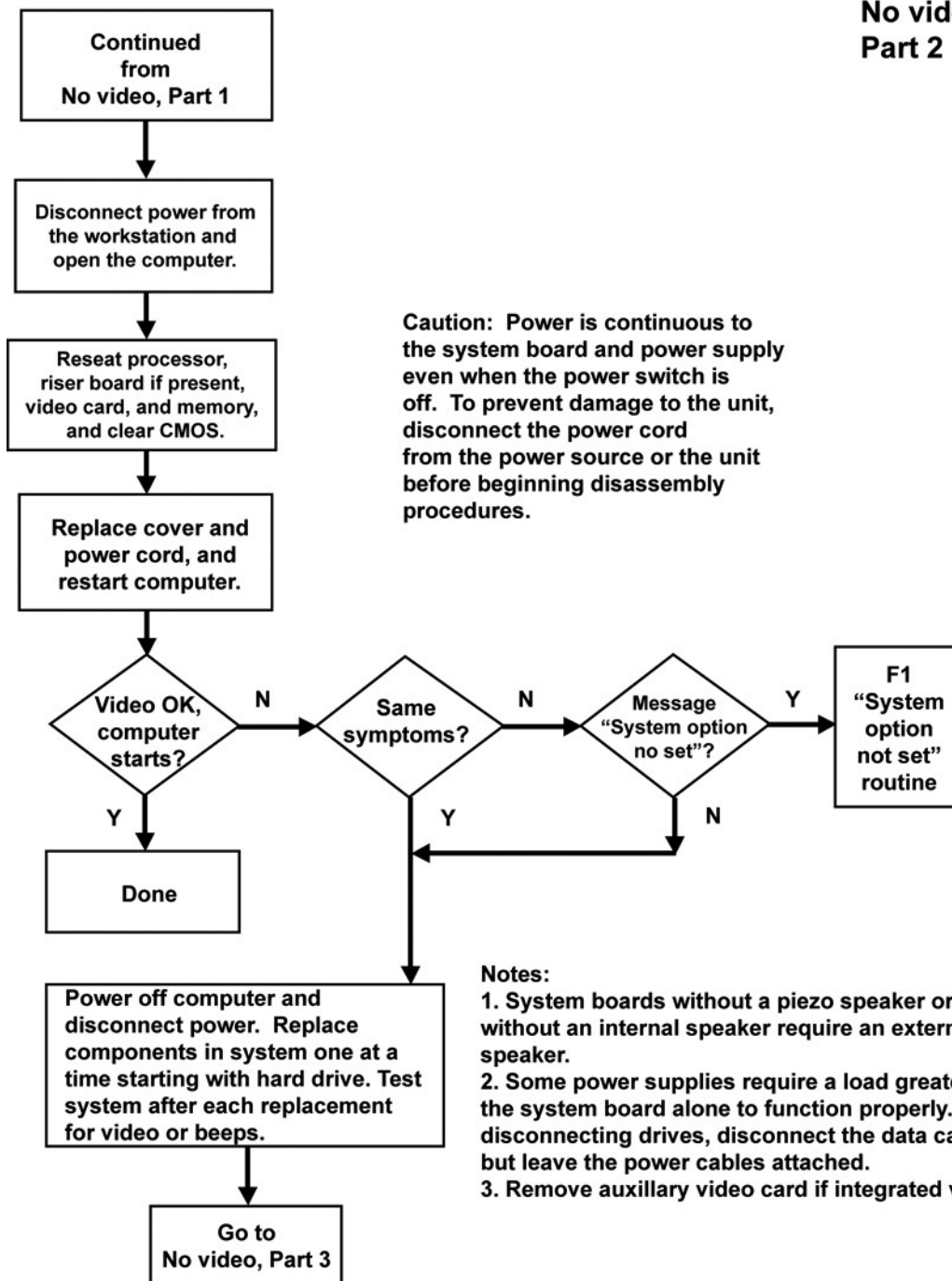

## No video, part 3

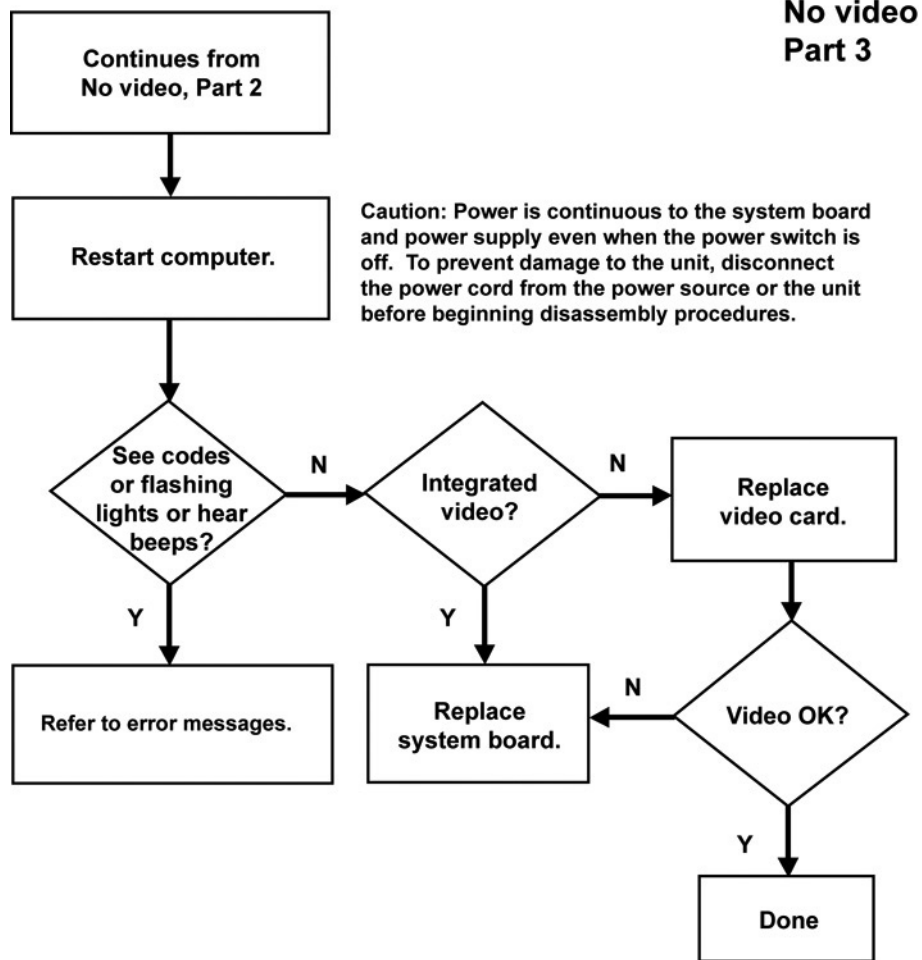

# Error messages

## Error messages, part 1

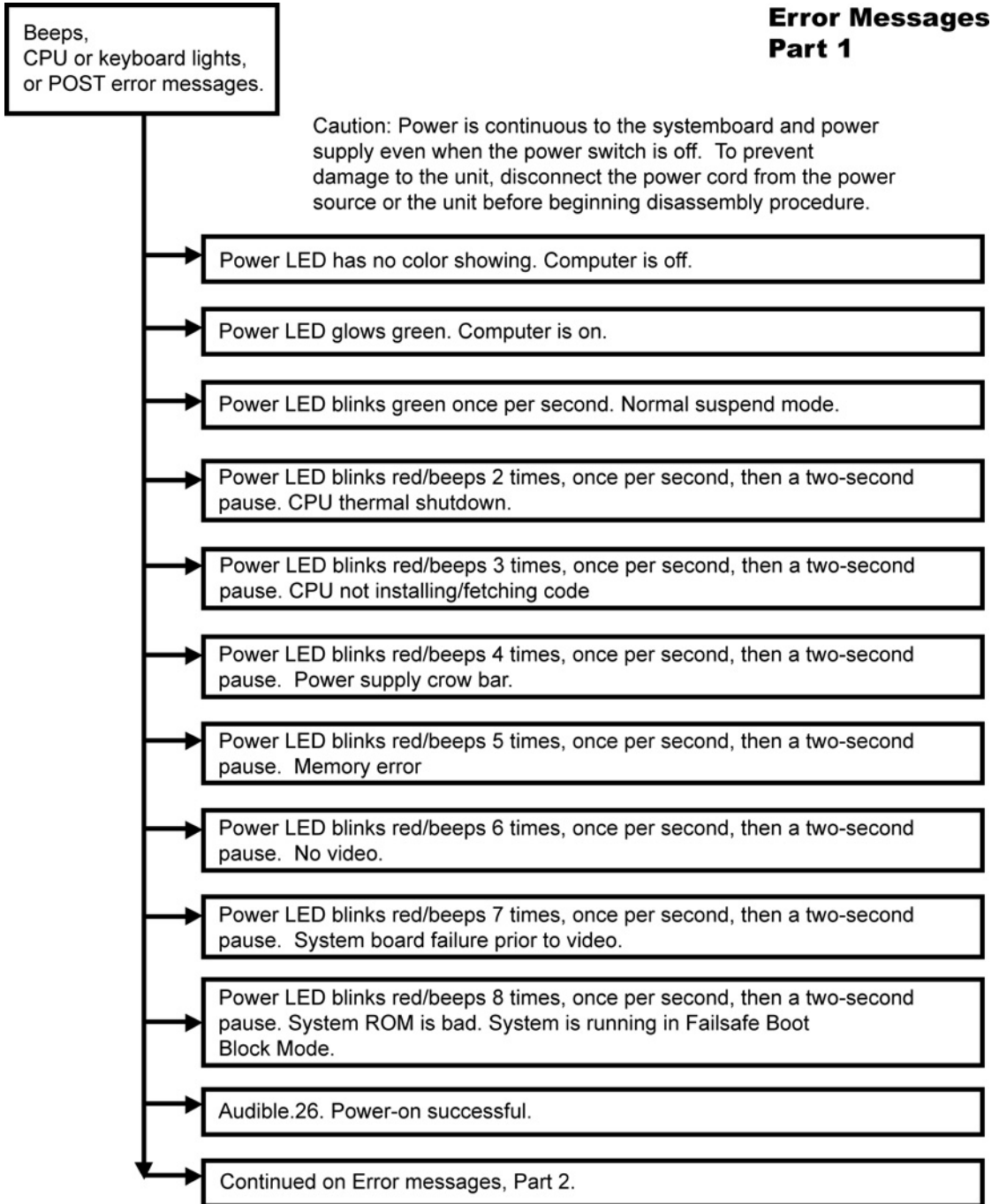

## Error messages, part 2

### Error messages Part 2

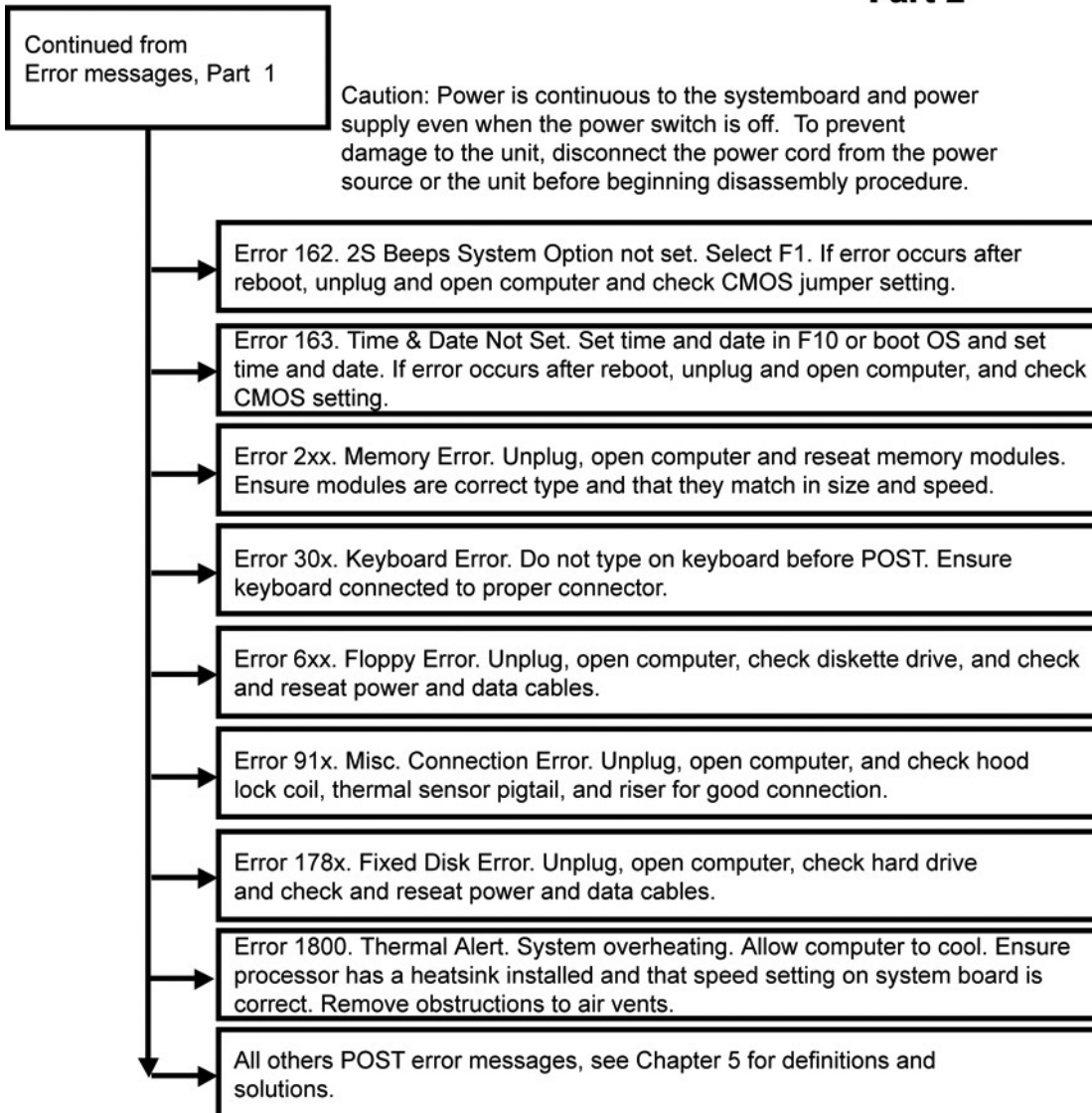

Notes: Short (S) and long (L) beeps will only be heard if the system has a speaker.  
LEDs will only function on PS/2 keyboards, not USB.  
x = Numbers 1 - 9

# No operating system loading

## No OS loading

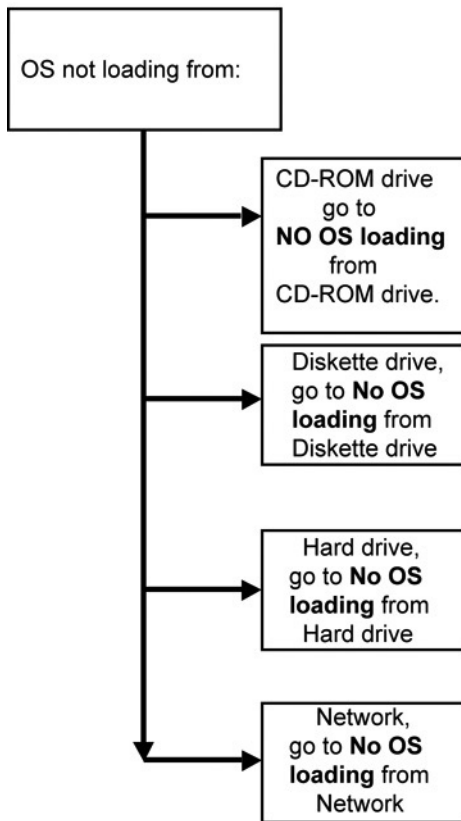

### Factory recommended booting priority

1. Optical drive
2. Diskette drive
3. Hard drive
4. Network

**NOTE:** Before beginning, always check drive jumpers, cable connections, cable ends, and drives for bent or damaged pins.



# No operating system loading from hard drive

## No operating loading from hard drive, part 1

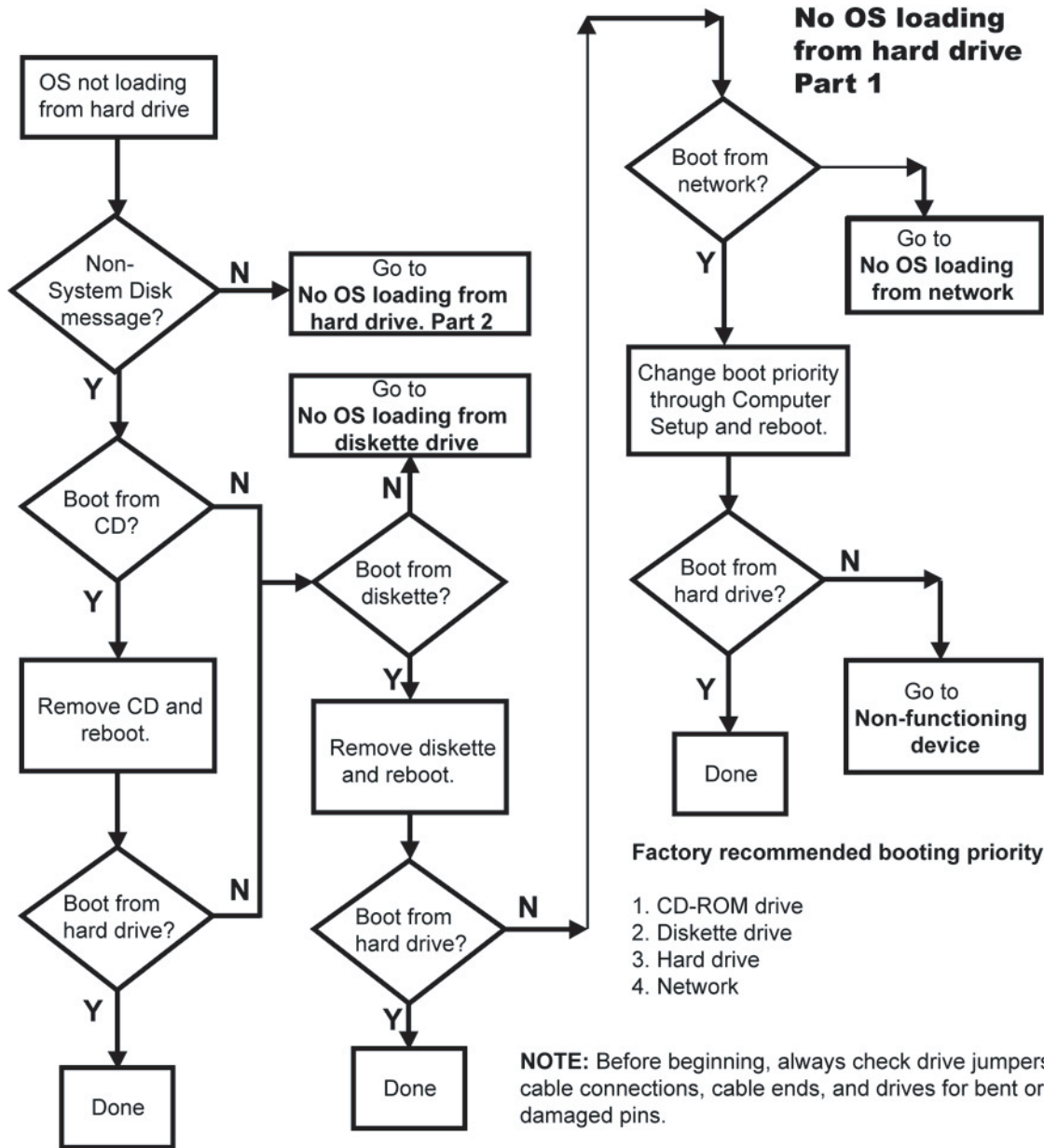



## No operating system loading from hard drive, part 2

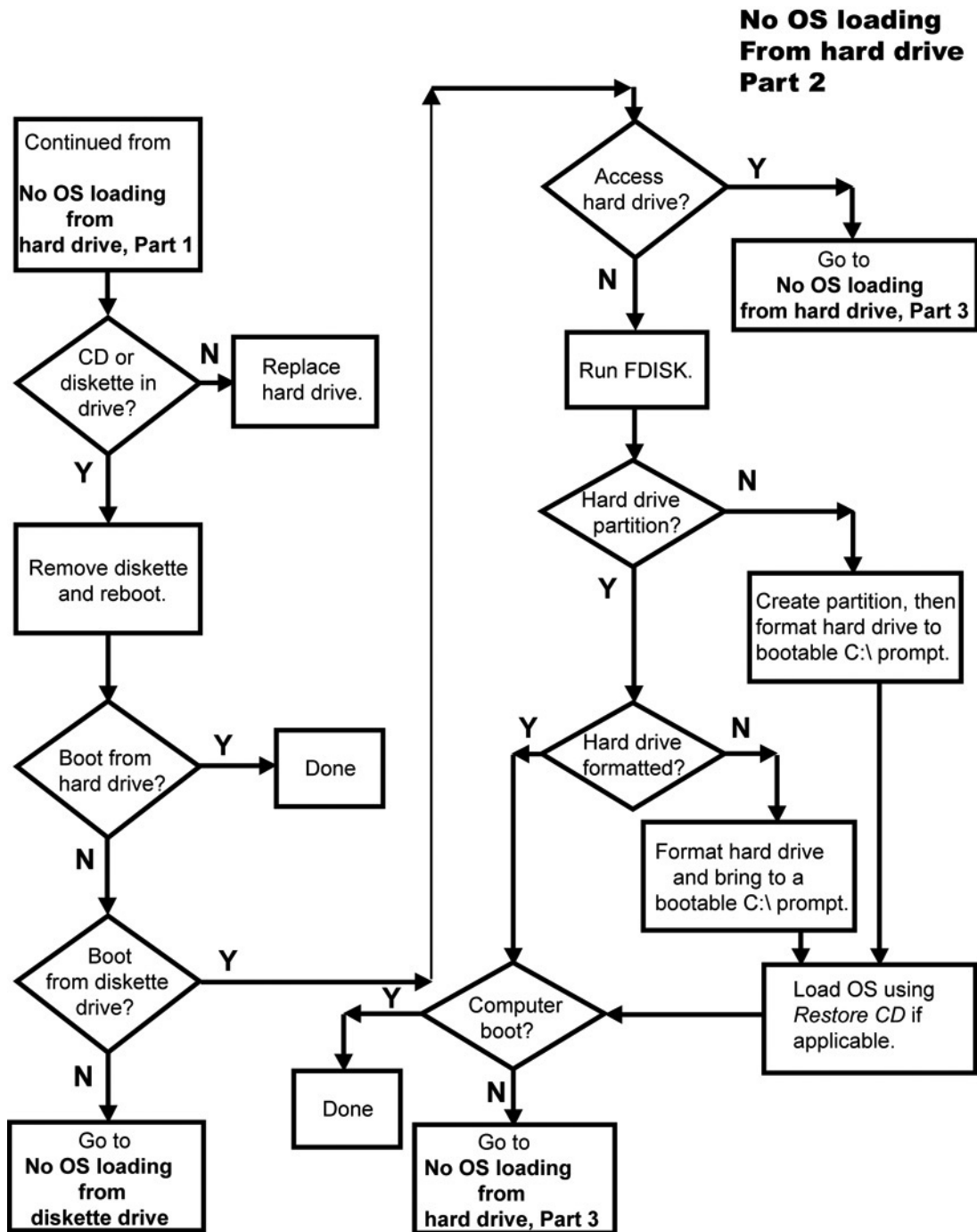

## No operating system loading from hard drive, part 3

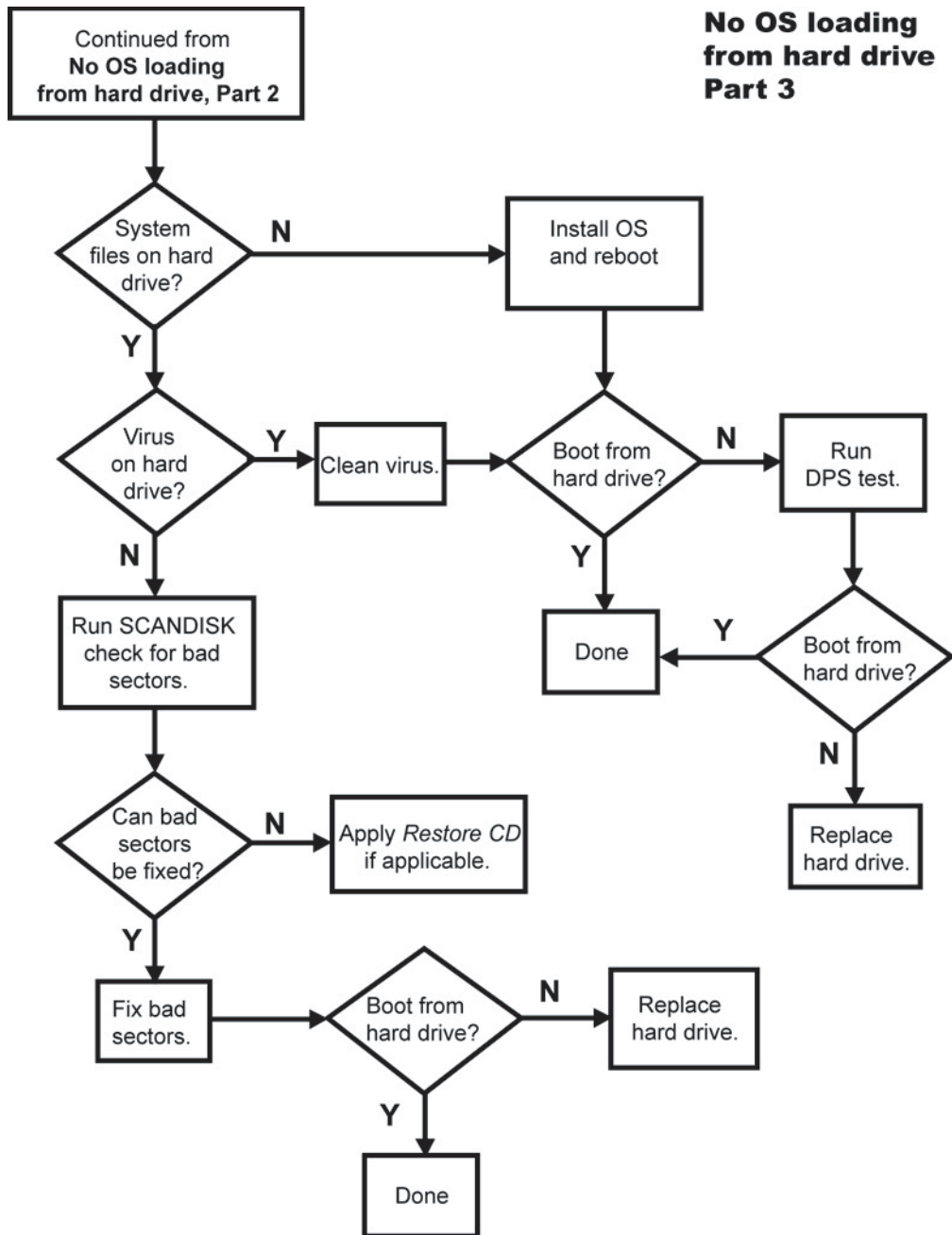

# No operating system loading from diskette drive

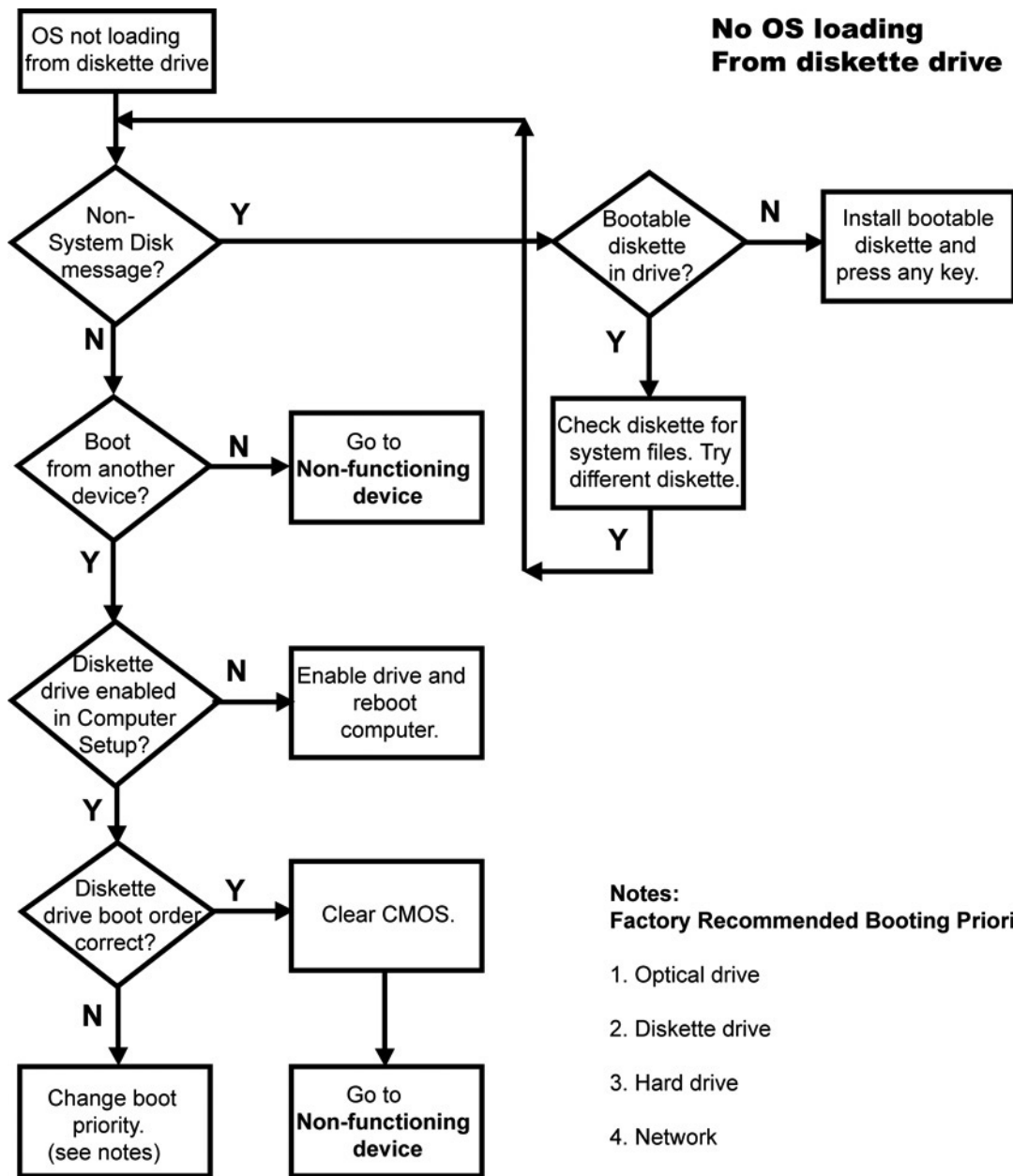

# No operating system loading from optical drive

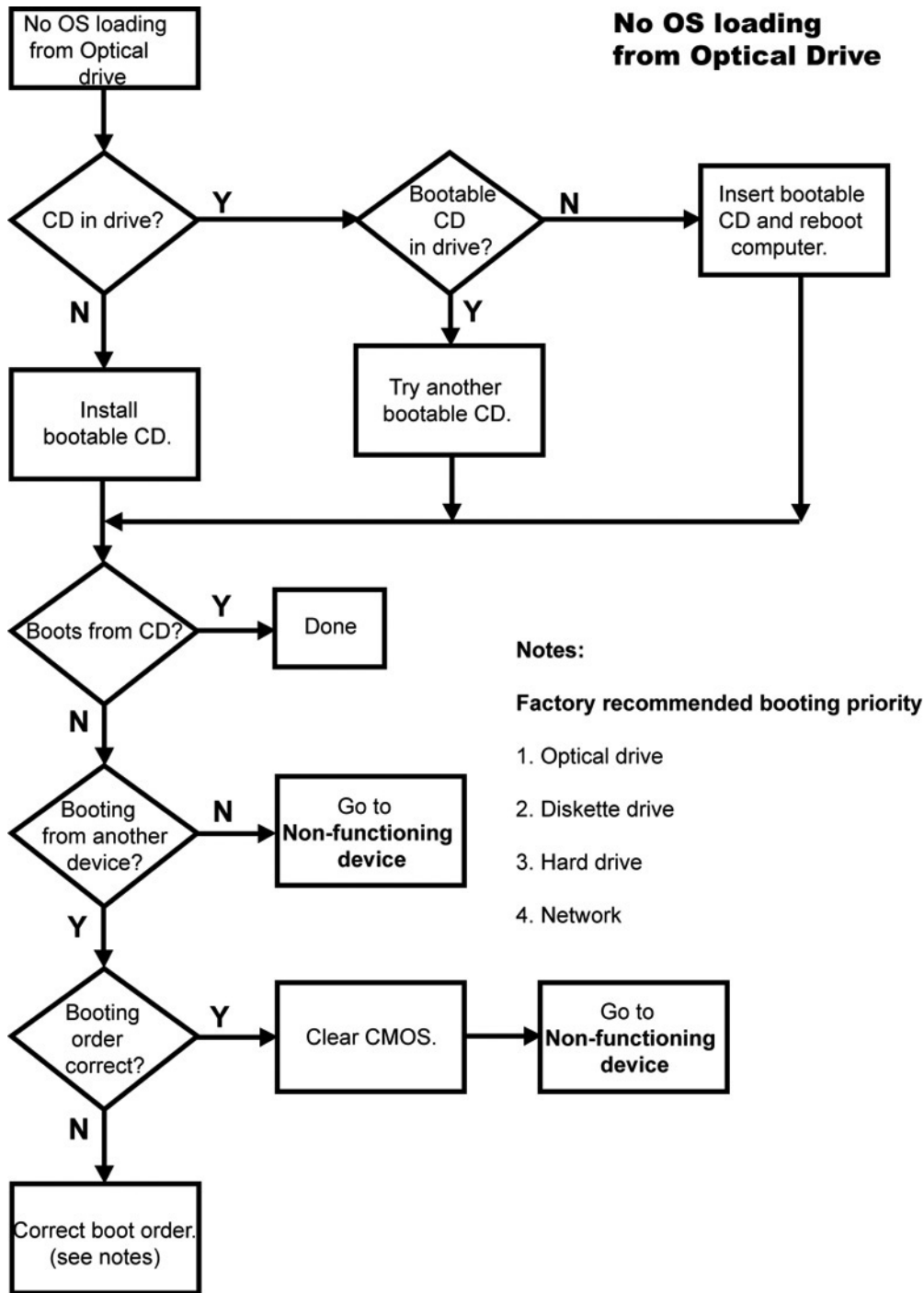

# No operating system loading from network

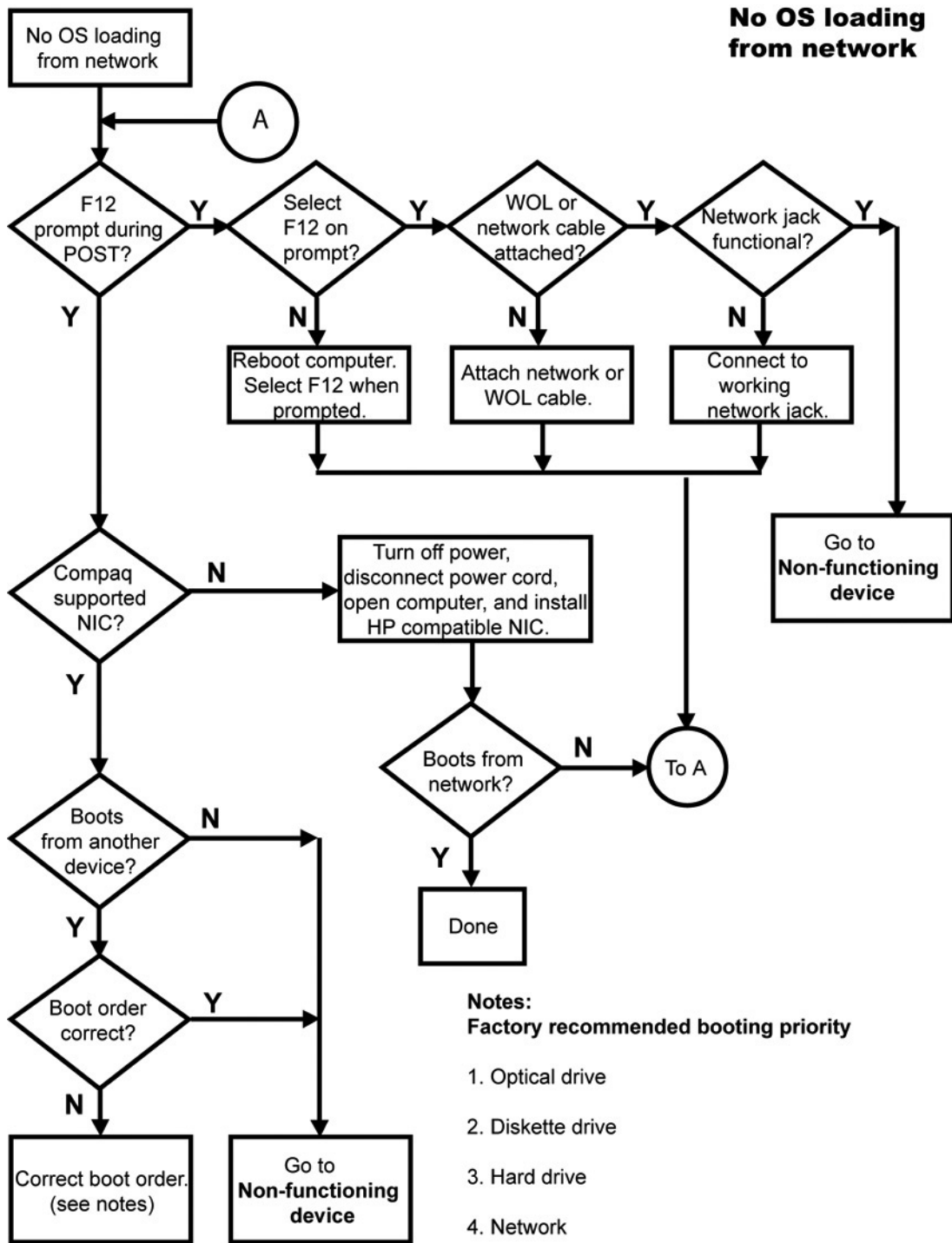

# Non-functioning device

## Non-functioning device

**Caution:** Power is continuous to the system board and power supply even when the power switch is off. To prevent damage to the unit, disconnect the power cord from the power source or the unit before beginning disassembly procedures.

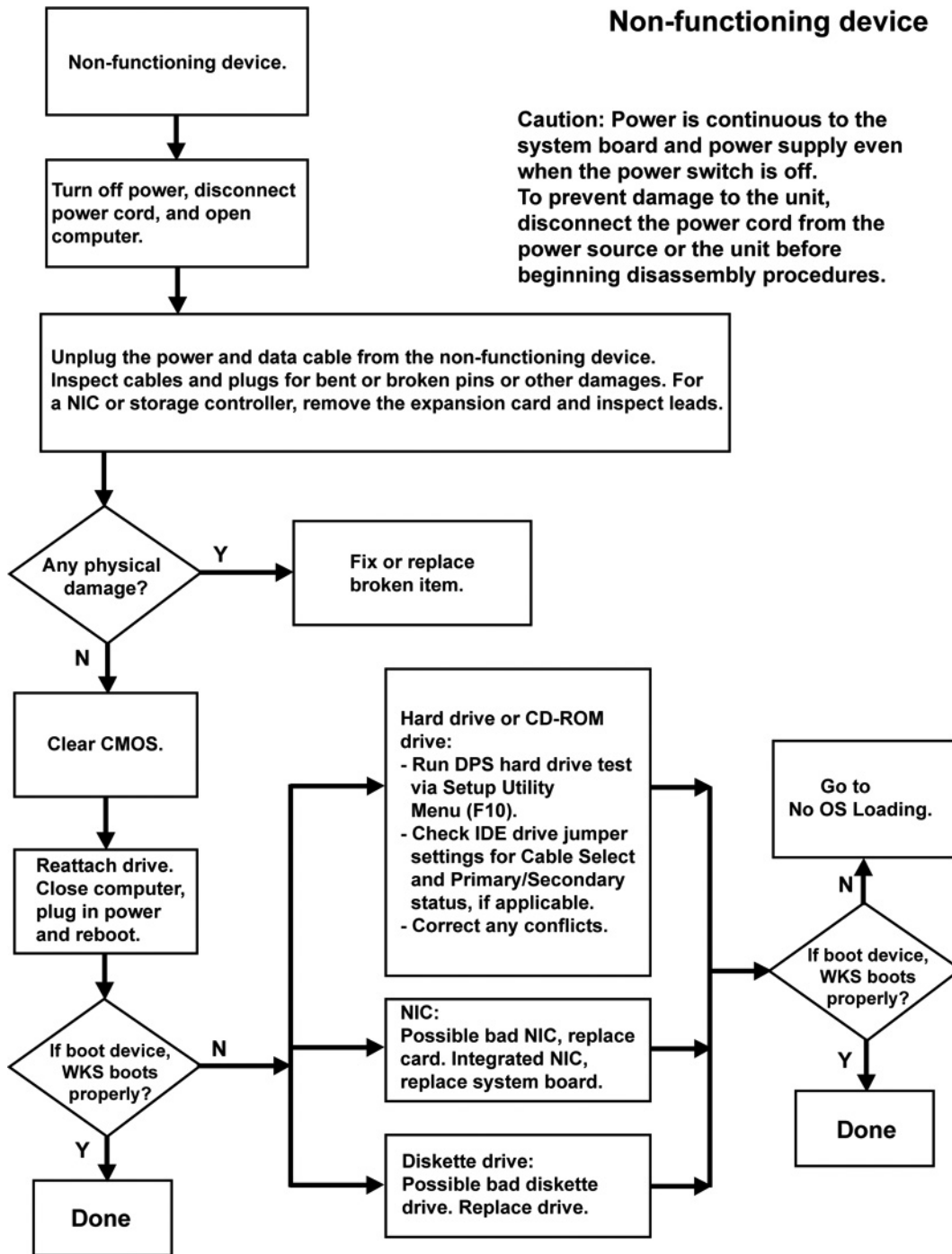

# I Appendix I—PCI bus layout

## PCI bus layout and device list

The following illustration shows the HP xw9400 Workstation PCI bus layout. It is followed by a PCI device list description.

**Figure I-1** PCI bus layout

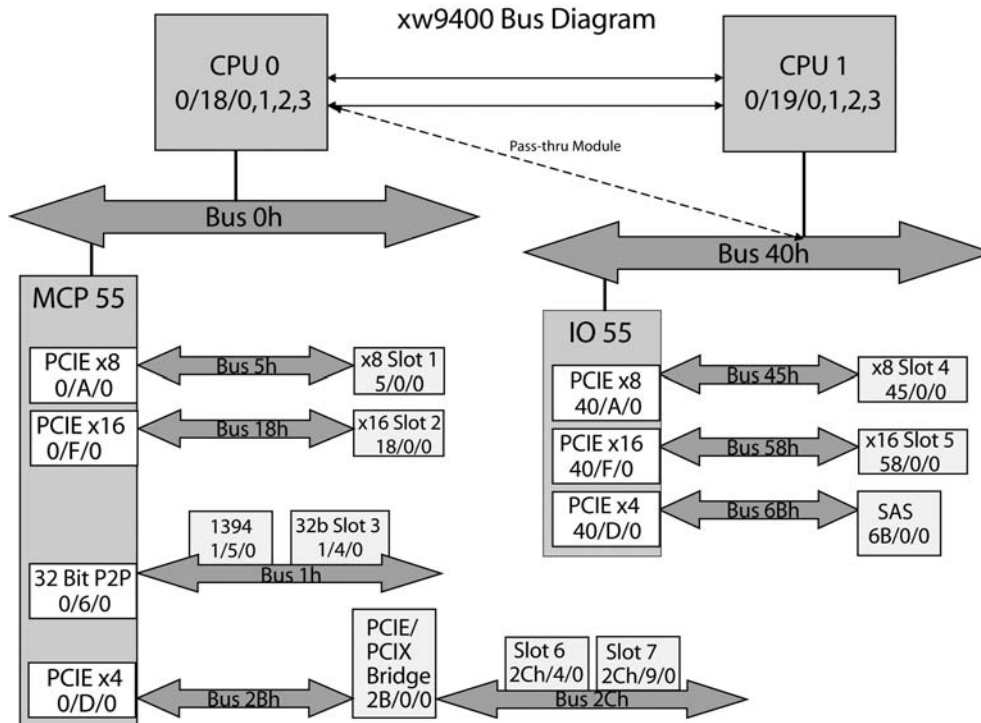

**Table I-1** PCI device list

Device	Bus#	Dev#	Fn#
MCP55ProPro HT Config	0	0	0
MCP55ProPro LPC	0	1	0
MCP55Pro SMBUS	0	1	1
MCP55Pro Trim	0	1	2
MCP55Pro ASF SMU	0	1	3
MCP55Pro USB OHCI	0	2	0
MCP55Pro USB EHCI	0	2	1
MCP55Pro IDE	0	4	0
MCP55Pro SATA0	0	5	0
MCP55Pro SATA1	0	5	1

**Table I-1 PCI device list (continued)**

Device	Bus#	Dev#	Fn#
MCP55Pro SATA2	0	5	2
MCP55Pro P2P Bridge (Bridge to Slot 3)	0	6	0
MCP55Pro High Definition Audio Controller	0	6	1
MCP55Pro LOM 0	0	8	0
MCP55Pro LOM 1	0	9	0
MCP55Pro PCIE Root Port 0 (Port to Slot 2)	0	F	0
MCP55Pro PCIE Root Port 2 (Port to NEC Bridge)	0	D	0
MCP55Pro PCIE Root Port 5 (Port to Slot 1)	0	A	0
IO55 HT Config	40h	0	0
IOP55 LPC	40h	1	0
IOP55 SMBUS	40h	1	1
IOP55 Trim	40h	1	2
IO55 PCIE Root Port 0 (Port to Slot 5)	40h	F	0
IO55 PCIE Root Port 2 (Port to SAS)	40h	D	0
IO55 PCIE Root Port 5( Port to Slot 4)	40h	A	0
Slot 1 (PCIEx8)	5h	0	0
Slot 2 (PCIEx16)	18h	0	0
Slot 3 (32 bit PCI )	1h	4	0
Slot 4 (PCIEx8)	45h	0	0
Slot 5 (PCIEx16)	58h	0	0
Slot 6 (PCIX 100)	2Ch	4	0
Slot 7 (PCIX 100/133)	2Ch	9	0
1394 Controller	1h	5	0
NEC PCIX Bridge Controller	2Bh	0	0
NEC PCIX Bridge Controller (No Physical Slot Connections)	2Bh	0	1
LSI SAS Controller	6Bh	0	0



---

# J Appendix J— Configuring SATA and PATA optical disk drives

This section provides information on the sequence in which the workstation detects and assigns optical disk drive (ODD) IDs and drive letters when both Serial ATA (SATA) and Parallel ATA (PATA) ODDs are installed in a workstation. It also provides configuration rules that determine which SATA ports are functional and which ports can be used to update system BIOS. The following information provides assumptions and configuration rules for installing SATA and PATA ODDs in the same workstation. It also provides configuration guidelines for installing SATA ODDs in the same workstation with SATA hard disk drives (HDDs).

## Drive detection and assignment sequence

When mixing PATA and SATA ODDs in a workstation, the PATA optical drive will always be detected first by the system. For example, if the first ODD is a SATA drive and the second ODD is a PATA drive, the system will detect the PATA ODD drive first. This will generally result in the PATA ODD being assigned the lower drive ID or drive designation letter by the operating system.

## Workstation SATA port configuration rules

Port configuration rules are determined individually by workstation product as shown in the following sections.

### HP w9400 Workstation BIOS configuration

When the xw9400 Workstation is set to RAID Mode in BIOS, any SATA ports that have an ODD connected to them must have RAID turned off.

### HP xw8400/xw6400/xw4400 Workstation SATA configuration mode settings

When the SATA Configuration Mode for these workstations is set to:

- Separate Mode - Only SATA ports 0, 1, 2, and 3 are functional for any SATA devices.
- Combined Mode - Only SATA ports 0 and 2 are functional for any SATA devices.
- RAID/AHCI Mode - You will not be able to update system BIOS from the SATA ODD.
- Combined Mode or Separate Mode - BIOS can be updated using a SATA ODD attached to functional ports.