



# **Hardware Reference Guide**

HP Compaq Business PC  
dc7600 Ultra-Slim Desktop Model

Document Part Number: 383421-001

**May 2005**

This guide provides detailed information on the features and use of the HP Compaq dc7600 Ultra-Slim Desktop, and includes instructions for removing and replacing internal components.

© Copyright 2005 Hewlett-Packard Development Company, L.P.  
The information contained herein is subject to change without notice.

Microsoft and Windows are trademarks of Microsoft Corporation in the U.S.  
and other countries.

The only warranties for HP products and services are set forth in the express  
warranty statements accompanying such products and services. Nothing herein  
should be construed as constituting an additional warranty. HP shall not be liable  
for technical or editorial errors or omissions contained herein.

This document contains proprietary information that is protected by copyright.  
No part of this document may be photocopied, reproduced, or translated to  
another language without the prior written consent of Hewlett-Packard  
Company.



**WARNING:** Text set off in this manner indicates that failure to follow  
directions could result in bodily harm or loss of life.

---



**CAUTION:** Text set off in this manner indicates that failure to follow  
directions could result in damage to equipment or loss of information.

---

## **Hardware Reference Guide**

HP Compaq Business PC  
dc7600 Ultra-Slim Desktop Model

First Edition (May 2005)

Document Part Number: 383421-001

---

# Contents

## 1 Product Features

Standard Configuration Features . . . . .	1-1
Front Panel Components . . . . .	1-2
Rear Panel Components . . . . .	1-3
Standard Keyboard Components . . . . .	1-4
Windows Logo Key . . . . .	1-5
Serial Number and Product ID Location . . . . .	1-6
Choose Tower or Desktop Configuration . . . . .	1-6

## 2 Hardware Upgrades

Removing and Replacing the Access Panel . . . . .	2-1
Removing and Replacing the Front Bezel and MultiBay . . . . .	2-3
Attaching and Removing the Tower Stand . . . . .	2-7
Installing Additional Memory . . . . .	2-11
DIMMs . . . . .	2-11
DDR2-SDRAM DIMMs . . . . .	2-11
DIMM Sockets . . . . .	2-12
Adding or Removing a Memory Module . . . . .	2-14
Adding or Removing an Expansion Card . . . . .	2-17
Installing an Expansion Card . . . . .	2-18
Removing an Expansion Card . . . . .	2-22
Upgrading the Hard Drive . . . . .	2-24
Working with the MultiBay . . . . .	2-28
“Hot-Plugging” or “Hot-Swapping” MultiBay Drives . . . . .	2-29
Engaging and Releasing the MultiBay Security Catch . . . . .	2-29
Removing a Drive from the MultiBay . . . . .	2-32
Inserting a Drive into the MultiBay . . . . .	2-33
Partitioning and Formatting a MultiBay Hard Drive . . . . .	2-34

## **A Specifications**

## **B Battery Replacement**

## **C Security Provisions**

Installing an Optional Security Lock . . . . .	C-1
Cable Lock . . . . .	C-1
Padlock . . . . .	C-2
Universal Chassis Clamp Lock . . . . .	C-3

## **D Electrostatic Discharge**

Preventing Electrostatic Damage . . . . .	D-1
Grounding Methods . . . . .	D-1

## **E Computer Operating Guidelines, Routine Care and Shipping Preparation**

Computer Operating Guidelines and Routine Care . . . . .	E-1
Optical Drive Precautions . . . . .	E-2
Operation . . . . .	E-2
Cleaning . . . . .	E-2
Safety . . . . .	E-2
Shipping Preparation . . . . .	E-3

## **Index**

---

# Product Features

## Standard Configuration Features

The Ultra-Slim Desktop computer comes with features that may vary depending on the model. For a complete listing of the hardware and software installed in the computer, run the diagnostics utility. Instructions for using this utility is provided in the *Troubleshooting Guide* on the *Documentation and Diagnostics CD*.



*Ultra-Slim Desktop*

## Front Panel Components

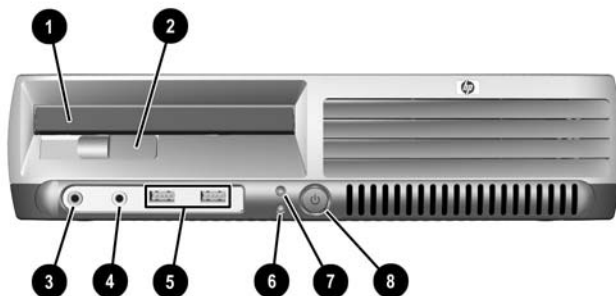

- 
- |                        |  |
|------------------------|--|
| ❶ MultiBay             | ❺ Universal Serial Bus (USB) Connector (2) |
| ❷ MultiBay Eject Lever | ❻ Power On Light                           |
| ❸ Microphone Connector | ❼ Hard Drive Activity Light                |
| ❹ Headphone Connector  | ❽ Dual-State Power Button                  |
- 

 Any USB device (including keyboard and mouse) can be connected to any USB connector.

---

## Rear Panel Components

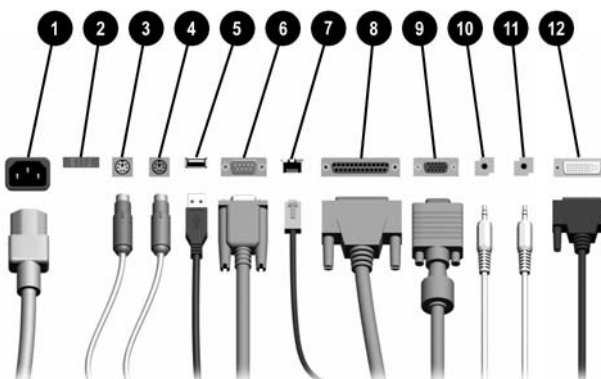

❶	Power Cord Connector	❷	무선 RJ-45 Network Connector
❸	Voltage Select Switch	❸	Parallel Connector
❹	🖱️ PS/2 Mouse Connector (green)	❹	🖥️ Monitor Connector
❺	⌨️ PS/2 Keyboard Connector (purple)	❺	🎵 Line-Out Connector (green) (for powered devices)
❻	🔌 Universal Serial Bus (USB)	❻	🎵 Line-In Audio Connector (blue)
❼	IOIOI Serial Connector	❼	🖥️ Digital Video Interface (DVI-D) Monitor Connector (optional)

📎 Arrangement and number of connectors may vary by model.

If a PCI graphics card is installed, the connectors on the card and the system board may be used at the same time. Some settings may need to be changed in F10 setup to use both connectors. For more information about Boot Order, refer to the *Computer Setup (F10) Utility Guide* on the *Documentation and Diagnostics CD*.

The optional DVI-D connector will only work with DVI displays. It cannot be adapted to support displays with analog inputs.

## Standard Keyboard Components

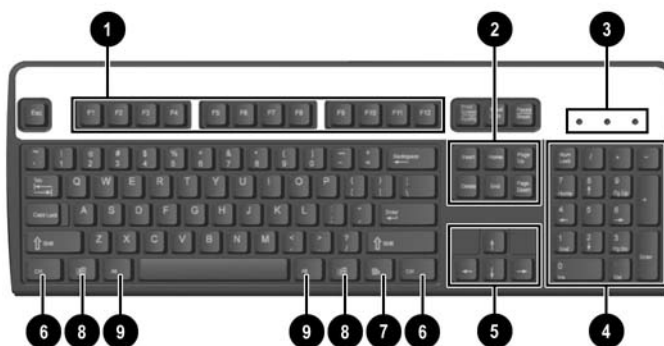

❶	Function Keys	Perform special functions, depending on the software application being used.
❷	Editing Keys	Include the following: <b>Insert</b> , <b>Home</b> , <b>Page Up</b> , <b>Delete</b> , <b>End</b> , and <b>Page Down</b> .
❸	Status Lights	Indicate the status of the computer and keyboard settings ( <b>Num Lock</b> , <b>Caps Lock</b> , and <b>Scroll Lock</b> ).
❹	Numeric Keys	Work like a calculator keypad.
❺	Arrow Keys	Used to navigate through a document or Web site. These keys allow you to move left, right, up, and down, using the keyboard instead of the mouse.
❻	Ctrl Keys	Used in combination with other keys; its effect depends on the application software you are using.
❼	Application Key*	Used (like the right mouse button) to open pop-up menus in a Microsoft Office application. May perform other functions in other software applications.
❽	Windows Logo Keys*	Used to open the Start menu in Microsoft Windows. Used in combination with other keys to perform other functions.
❾	Alt Keys	Used in combination with other keys; its effect depends on the application software you are using.

\*Keys available in some geographic regions.



---

## Windows Logo Key

Use the Windows Logo Key in combination with other keys to perform certain functions available in the Windows operating system.

Windows Logo Key	Display or hide the Start menu.
Windows Logo Key + <b>Break</b>	Display the System Properties dialog box.
Windows Logo Key + <b>F1</b>	Display Help for the Windows operating system.
Windows Logo Key + <b>Tab</b>	Switch between open items.
Windows Logo Key + <b>e</b>	Open My Computer.
Windows Logo Key + <b>f</b>	Search for a file or folder.
Windows Logo Key + <b>Ctrl + f</b>	Search for computers.
Windows Logo Key + <b>m</b>	Minimize or restore all windows.
Windows Logo Key + <b>Shift + m</b>	Undo Minimize All.
Windows Logo Key + <b>r</b>	Open the Run dialog box.

## Serial Number and Product ID Location

Each Ultra-Slim Desktop computer has a unique serial number and a product ID number that are located on the top of the computer when it is in the tower configuration. Keep these numbers available for use when contacting customer service for assistance.



*Serial Number Location*

## Choose Tower or Desktop Configuration

The Ultra-Slim Desktop computer can be used in either a tower or desktop configuration. To use it in a tower configuration, refer to [“Attaching and Removing the Tower Stand”](#) on page 2–7 for more information.

To use the computer in the desktop configuration, make sure the side with rubber pads is down.



**CAUTION:** To ensure stability and adequate airflow, help prevent overheating, and ensure warranty protection, the Ultra-Slim Desktop must be used with a Tower Stand in a tower configuration. Ensure adequate airflow by keeping at least 10.2 cm (4 inches) of space on all sides of the computer clear and free of obstruction.

---

---

## Hardware Upgrades

### Removing and Replacing the Access Panel



**WARNING:** To reduce the risk of personal injury from electrical shock and/or hot surfaces, be sure to disconnect the power cord from the wall outlet, and allow the internal system components to cool before touching.

---



**WARNING:** To reduce the risk of electrical shock, fire, or damage to the equipment, do not plug telecommunications or telephone connectors into the network interface controller (NIC) receptacles.

---



**CAUTION:** Static electricity can damage the electronic components of the computer or optional equipment. Before beginning these procedures, ensure that you are discharged of static electricity by briefly touching a grounded metal object. See [Appendix D, “Electrostatic Discharge”](#) for more information.

---



**CAUTION:** When the computer is plugged into an AC power source, voltage is always applied to the system board. You must disconnect the power cord from the power source before opening the computer to prevent system board damage.

---

To access system memory, the expansion slot assembly, and the battery, you must remove the access panel:

1. If the Smart Cover Sensor is enabled, restart the computer and enter Computer Setup to disable it.
2. Turn off the computer properly through the operating system, then turn off any external devices.
3. Disconnect the power cord from the power outlet and the computer, and disconnect any external devices.



An optional cable lock may be used to secure the access panel, preventing access to internal components including system memory, the internal hard drive, and the MultiBay security catch. It may also be used to secure the computer to a fixed object.

For more information on installing or removing these security devices, refer to [Appendix C, “Security Provisions.”](#)

---

4. Remove the optional cable lock, if installed.
5. Position the computer on its side with the rubber pads on the bottom. (If the computer is being used in the tower configuration, remove the stand first. Refer to [“Attaching and Removing the Tower Stand”](#) on page 2-7 for more information.)
6. Loosen the thumbscrew on the rear of the computer ❶, slide the access panel toward the rear of the computer ❷, then lift it off.

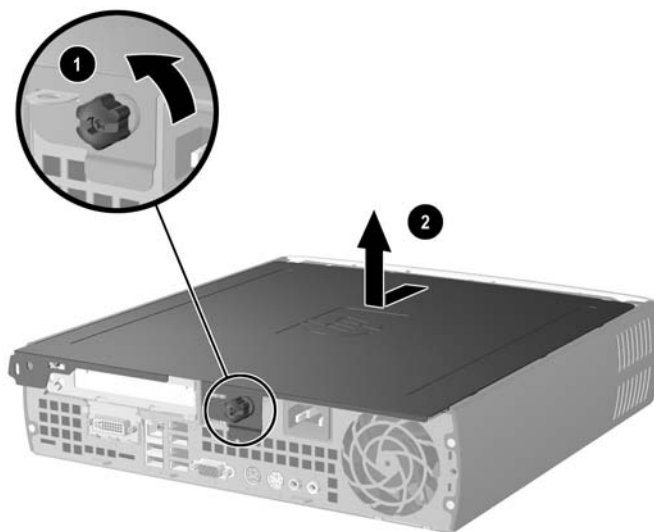

*Removing the Access Panel*

To replace the access panel:

1. Ensure that the panel is aligned properly, then slide it toward the front of the computer and tighten the thumbscrew to secure it.
2. Install the optional cable lock, if desired.
3. Replace the stand, if desired.
4. Reconnect all external devices, plug the power cord into the power outlet, and turn the computer on.
5. Use Computer Setup to enable the Smart Cover Sensor, if desired.

## Removing and Replacing the Front Bezel and MultiBay

To access the internal hard drive, you must remove the front bezel and MultiBay.

1. If the Smart Cover Sensor is enabled, restart the computer and enter Computer Setup to disable it.
2. Turn off the computer properly through the operating system, then turn off any external devices.
3. Disconnect the power cord from the power outlet and the computer, and disconnect any external devices.
4. Position the computer on its side with the rubber pads on the bottom. (If the computer is being used in the tower configuration, remove the computer from the stand. Refer to [“Attaching and Removing the Tower Stand” on page 2–7](#) for more information.)
5. Remove the access panel. Refer to [“Removing and Replacing the Access Panel” on page 2–1](#) for more information.
6. Remove the drive from the MultiBay. Refer to [“Removing a Drive from the MultiBay” on page 2–32](#) for more information.

7. Remove the MultiBay daughter card by pulling it straight up out of the computer.

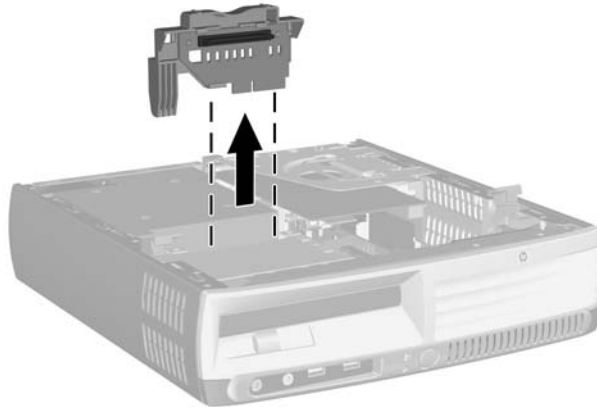

*Removing the MultiBay Daughter Card*

8. Disconnect the fan cable.

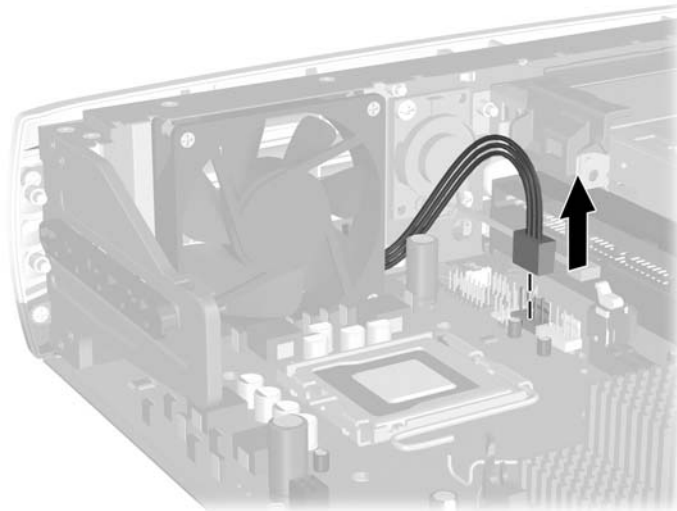

*Disconnecting the Fan Cable*

9. Disconnect the speaker cable.

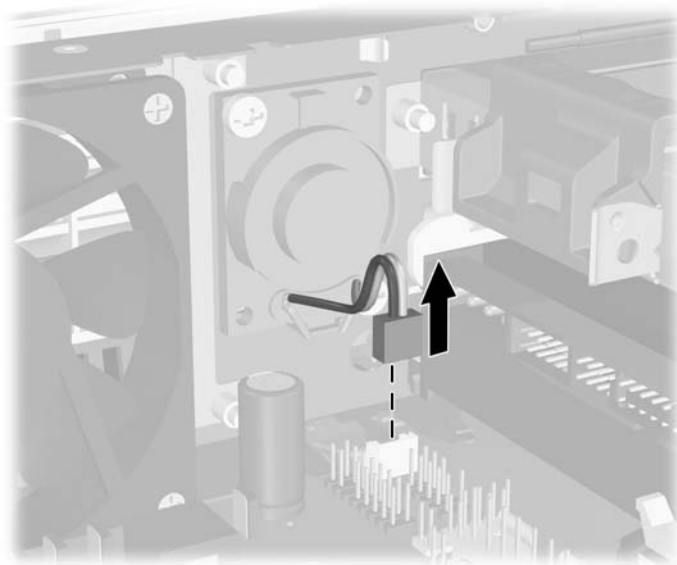

*Disconnecting the Speaker Cable*

10. Pull the lever on each side of the computer chassis up and toward the rear of the computer ❶, and pull the front bezel and attached MultiBay forward and off the computer ❷.

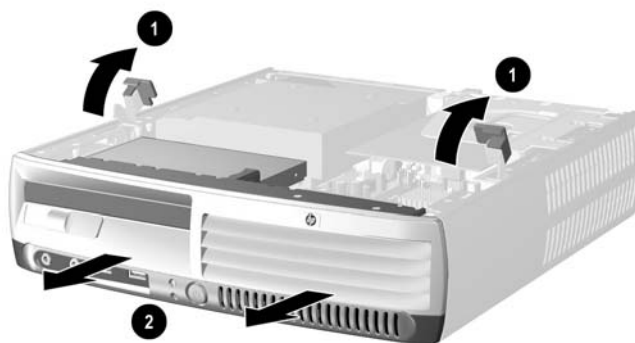

#### *Removing the Front Bezel and MultiBay*

To replace the front bezel and MultiBay:

1. Ensure that the front bezel and MultiBay are aligned properly, then slide the assembly toward the rear of the computer until it is properly seated. The latch on each side of the computer chassis will return to its original position.
2. Reconnect the speaker cable.
3. Reconnect the fan cable.
4. Replace the MultiBay daughter card by carefully aligning the card with the connector slot and pressing the card firmly into place.
5. Replace the MultiBay drive. Refer to [“Inserting a Drive into the MultiBay” on page 2–33](#) for more information.
6. Replace the access panel.
7. Replace the stand, if desired.
8. Reconnect all external devices, plug the power cord into the power outlet, and turn the computer on.
9. Use Computer Setup to enable the Smart Cover Sensor, if desired.



## Attaching and Removing the Tower Stand

To use the Ultra-Slim Desktop computer in the tower configuration:

1. Exit all software applications, shut down the operating system software, turn off the computer and any external devices, then disconnect the power cord from the power outlet.
2. Rotate the computer into the tower position with the MultiBay and fan on the bottom and the PCI expansion slot on the top.



*Rotating the Computer into the Tower Position*

3. Lower the computer into the stand so that the hooks on the front of the tower stand fit into the vents on the bottom of the computer, then slide the computer back until the hooks engage ❶.
4. Tighten the screw to secure the computer to the stand ❷. This adds stability and helps to ensure proper airflow to the internal components.



*Attaching the Stand to the Computer*

5. Reconnect all external devices, plug the power cord into the power outlet, and turn the computer on.

To remove the stand from the computer:

1. Exit all software applications, shut down the operating system software, turn off the computer and any external devices, then disconnect the power cord from the power outlet.
2. Loosen the thumbscrew that secures the computer to the stand **1**.
3. Slide the computer forward until it is disengaged from the hooks on the front of the tower stand, then lift the computer up off the stand **2**.

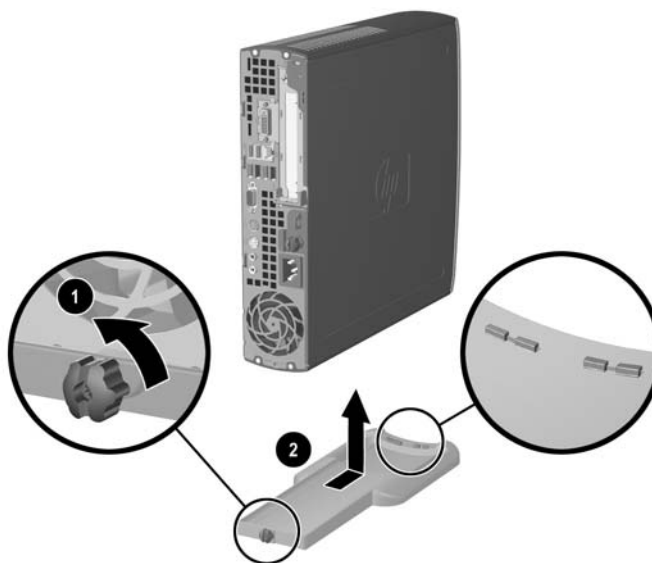

*Removing the Stand from the Computer*

4. Lay the computer on its side with the rubber pads on the bottom.



*Rotating the Computer into the Desktop Position*

5. Reconnect all external devices, plug the power cord into the power outlet, and turn the computer on.

## Installing Additional Memory

The computer comes with double data rate 2 synchronous dynamic random access memory (DDR2-SDRAM) dual inline memory modules (DIMMs).

### DIMMs

The memory sockets on the system board can be populated with up to three industry-standard DIMMs. These memory sockets are populated with at least one preinstalled DIMM. To achieve the maximum memory support, you can populate the system board with up to 4GB of memory configured in a high-performing dual channel mode.

### DDR2-SDRAM DIMMs

For proper system operation, the DIMMs must be:

- industry-standard 240-pin
- unbuffered PC2-4200 533 MHz
- 1.8 volt DDR2-SDRAM DIMMs

The DDR2-SDRAM DIMMs must also:

- support CAS latency 4 (CL = 4) for DDR2/533 MHz
- contain the mandatory Joint Electronic Device Engineering Council (JEDEC) DDR2 DIMM specification

In addition, the system supports:

- 256Mbit, 512Mbit, and 1Gbit non-ECC memory technologies
- single-sided and double-sided DIMMs
- DIMMs constructed with x8 and x16 DDR devices; DIMMs constructed with x4 SDRAM are not supported.



The system will not start if you install unsupported DIMMs.

---

Refer to the *Computer Setup (F10) Utility Guide* on the *Documentation and Diagnostics* CD for information on how to determine the processor bus frequency of a specific computer.

## DIMM Sockets

The system will automatically operate in single channel mode, dual channel Asymmetric mode, or a higher-performing dual channel Interleaved mode, depending on how the DIMMs are installed.

- The system will operate in a single channel mode if the DIMM sockets are populated in one channel only.
- The system will operate in dual channel Asymmetric mode if the total memory capacity of the DIMMs in Channel A is not equal to the total memory capacity of DIMMs in Channel B.
- The system will operate in a higher-performing dual channel Interleaved mode if the total memory capacity of the DIMMs in Channel A is equal to the total memory capacity of the DIMMs in Channel B. However, the technology and device width can vary between the channels. For example, if Channel A is populated with one 512MB DIMM and Channel B is populated with two 256MB DIMMs, the system will operate in Interleaved mode.

There are three DIMM sockets on the system board, with one socket in memory Channel A and two sockets in memory Channel B. The sockets are labeled XMM1, XMM3, and XMM4. Socket XMM1 operates in memory Channel A; sockets XMM3 and XMM4 operate in memory Channel B.

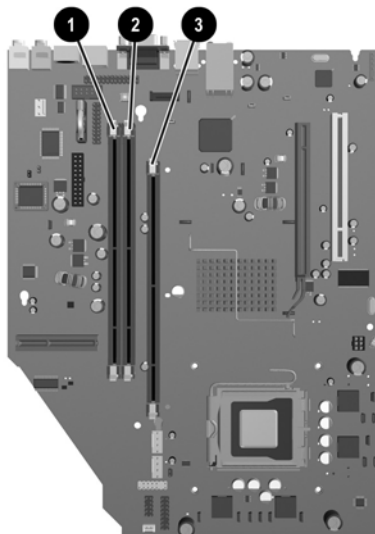

*DIMM Socket Locations*

<b>Item</b>	<b>Description</b>	<b>Socket Color</b>
❶	DIMM socket XMM3, Channel B	Black
❷	DIMM socket XMM4, Channel B	White
❸	DIMM socket XMM1, Channel A	Black

## Adding or Removing a Memory Module

---

 **CAUTION:** The memory module sockets have gold-plated metal contacts. When upgrading the memory, it is important to use memory modules with gold-plated metal contacts to prevent corrosion and/or oxidation resulting from having incompatible metals in contact with each other.

---

 **CAUTION:** Static electricity can damage the electronic components of the computer. Before beginning these procedures, ensure that you are discharged of static electricity by briefly touching a grounded metal object. See [Appendix D, “Electrostatic Discharge”](#) for more information.

---

 **CAUTION:** When handling a memory module, be careful not to touch any of the contacts. Doing so may damage the module.

---

1. If the Smart Cover Sensor is enabled, restart the computer and enter Computer Setup to disable it.
  2. Turn off the computer properly through the operating system, then turn off any external devices.
  3. Disconnect the power cord from the power outlet and the computer, and disconnect any external devices.
  4. Position the computer on its side with the rubber pads on the bottom. (If the computer is being used in the tower configuration, remove the computer from the stand. Refer to [“Attaching and Removing the Tower Stand”](#) on page 2–7 for more information.)
  5. Remove the access panel. Refer to [“Removing and Replacing the Access Panel”](#) on page 2–1 for more information.
  6. Locate the memory module sockets on the system board.
- 

 **WARNING:** To reduce the risk of personal injury from hot surfaces, allow the internal system components to cool before touching.

---



7. To remove a module,
  - a. Press out on both latches ❶ of the DIMM socket at the same time. This releases the module and partially pushes it out of the socket.
  - b. Lift the module from the socket ❷.

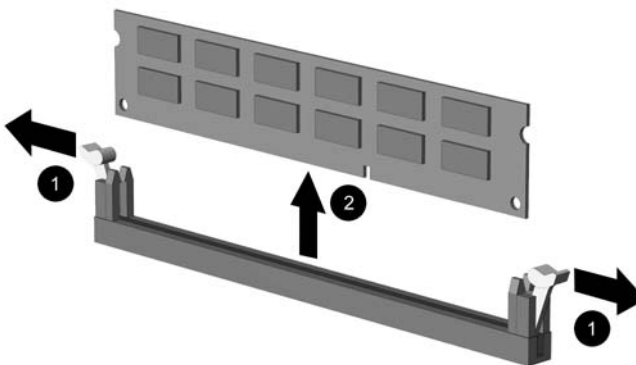

### *Removing Memory Modules*



If only one memory module is used in the system, it must be installed in the same socket that held the preinstalled memory module.

---

8. To install a memory module:

- a. Press out on both latches ❶ of the DIMM socket.
- b. Match the notch on the module with the tab on the memory socket. **Firmly** push the module straight into the socket ❷, ensuring that the module is fully inserted and properly seated. The latches will close automatically when the module is seated correctly, securing the module in the slot ❸.

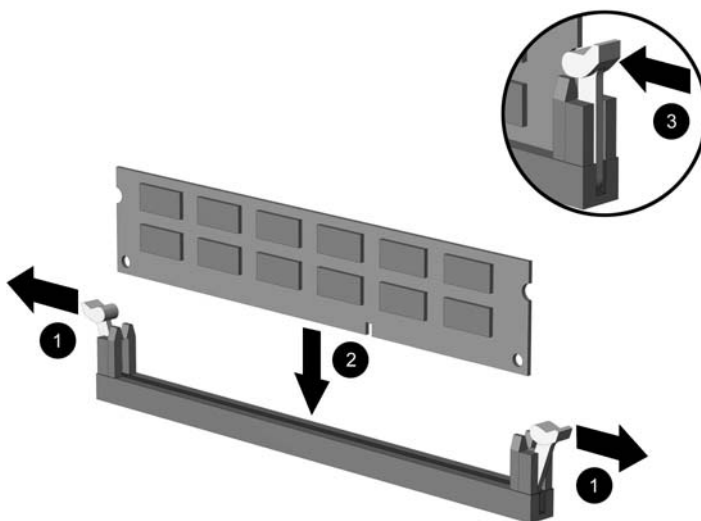

### *Adding Memory Modules*

---



A memory module can be installed in only one way. Match the notch on the module with the tab on the memory socket.

---



For maximum performance, populate the sockets so that the memory capacity of Channel A is equal to the total memory capacity of Channel B. For example, if you have one preinstalled DIMM in socket XMM1 (Channel A) and are adding a second DIMM, it is recommended the second DIMM be of equal memory capacity.

---

9. Replace the access panel.
10. Replace the stand, if desired.
11. Reconnect all external devices, plug the power cord into the power outlet, and turn the computer on.

The computer automatically recognizes the additional memory when you turn on the computer.

12. Use Computer Setup to enable the Smart Cover Sensor, if desired.

## Adding or Removing an Expansion Card

---



Adding an expansion card requires an optional expansion card assembly with riser card, which can be obtained from HP or an authorized provider.

---

The computer has one full-height, half-length PCI expansion slot that can accommodate an optional expansion card 10.67 cm (4.2 inches) in height and up to 16.76 cm (6.6 inches) in length. A variety of optional PCI cards are available including:

- Wireless LAN card
  - FireWire card
  - Modem card
  - NIC card
  - Graphics card
- 



Adding a graphics card will, by default, disable the integrated graphics on the system board. The integrated graphics can be reenabled by changing the BIOS settings in Computer Setup.

---



A USDT serial/parallel I/O assembly, available as an option, replaces the expansion slot cover and connects directly to the system board.

---

## Installing an Expansion Card

---



This procedure requires an optional expansion card assembly with riser card, which can be obtained from HP or an authorized provider.

---

1. If the Smart Cover Sensor is enabled, restart the computer and enter Computer Setup to disable it.
2. Turn off the computer properly through the operating system, then turn off any external devices.
3. Disconnect the power cord from the power outlet and the computer, and disconnect any external devices.
4. Position the computer on its side with the rubber pads on the bottom. (If the computer is being used in the tower configuration, remove the computer from the stand. Refer to [“Attaching and Removing the Tower Stand”](#) on page 2–7 for more information.)
5. Remove the access panel (refer to [“Removing and Replacing the Access Panel”](#) on page 2–1 for more information).
6. Lift the handle **1** on the expansion card assembly and pull the assembly straight up out of the computer **2**.

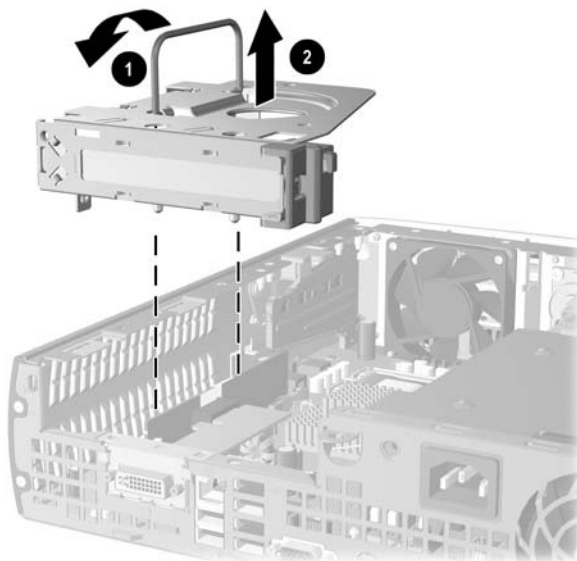

*Removing the Expansion Card Assembly*

7. Remove the expansion slot cover from the new expansion card assembly with riser card:
  - a. If the latch is not open, squeeze the sides of the latch together to release it ❶.
  - b. Open the latch ❷.
  - c. Pull the expansion card slot cover straight up out of the expansion card assembly ❸.

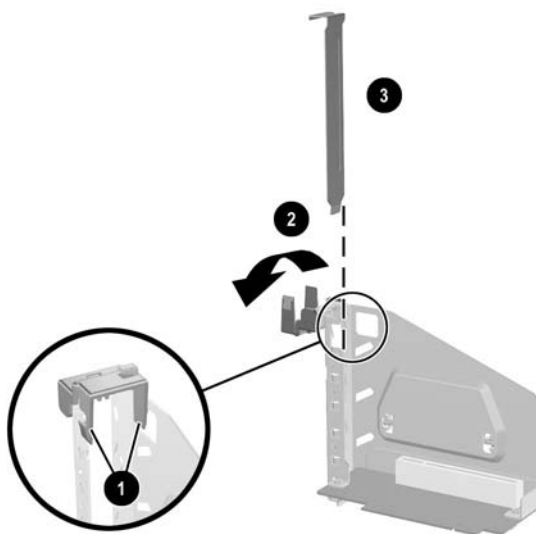

*Removing an Expansion Card Slot Cover*

8. Install the expansion card:
  - a. If the latch is not open, squeeze the sides of the latch together to release it ❶.
  - b. Open the latch ❷.
  - c. Slide the expansion card firmly into the expansion card slot until it is properly seated ❸.

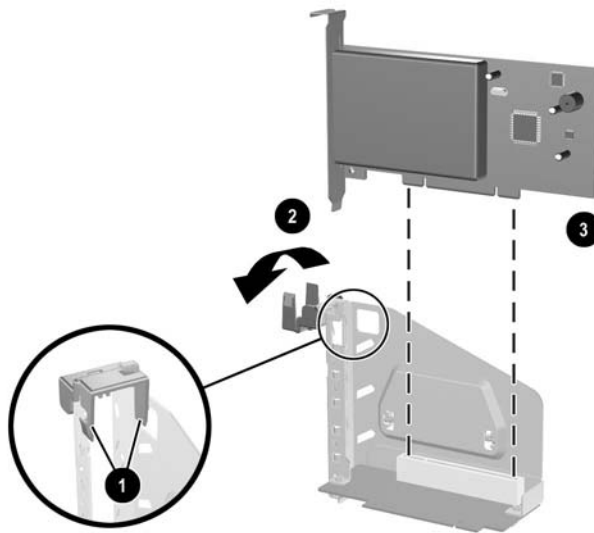

#### *Installing an Expansion Card*

---



When you install an expansion card, make sure you press firmly on the card so that the whole connector seats properly in the expansion card socket.

---

9. Close the expansion card retention latch, making sure that it snaps firmly into place.

10. Line up the tabs on the expansion card assembly with the slots on the computer chassis and press the assembly firmly down into place.

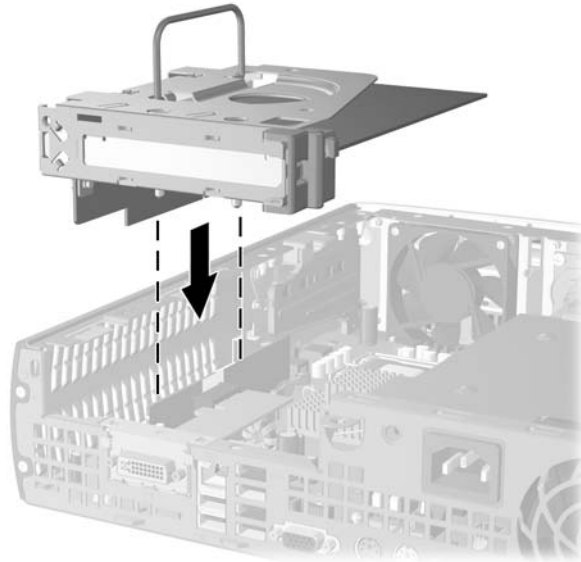

#### *Installing the Expansion Card Assembly*

11. Connect external cables to the installed card, if needed. Connect internal cables to the system board, if needed. If the card requires audio, connect the audio cable to the connector on the system board labeled “Aux” (located under the power supply cage).
12. Replace the access panel.
13. Install the optional cable lock, if desired.
14. Replace the stand, if desired.
15. Reconnect all external devices, plug the power cord into the power outlet, and turn the computer on.
16. Use Computer Setup to enable the Smart Cover Sensor, if desired.

## Removing an Expansion Card

1. If the Smart Cover Sensor is enabled, restart the computer and enter Computer Setup to disable it.
2. Turn off the computer properly through the operating system, then turn off any external devices.
3. Disconnect the power cord from the power outlet and the computer, and disconnect any external devices.
4. Position the computer on its side with the rubber pads on the bottom. (If the computer is being used in the tower configuration, remove the computer from the stand. Refer to [“Attaching and Removing the Tower Stand”](#) on page 2-7 for more information.)
5. Remove the access panel (refer to [“Removing and Replacing the Access Panel”](#) on page 2-1 for more information).
6. Lift the handle ❶ on the expansion card assembly and pull the assembly straight up out of the computer ❷.

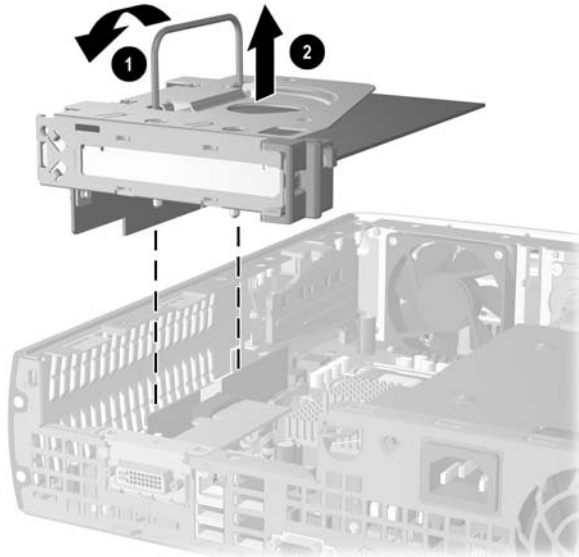

*Removing the Expansion Card Assembly*



7. Remove the expansion card:
  - a. If the latch is not open, squeeze the sides of the latch together to release it ❶.
  - b. Open the latch ❷.
  - c. Hold the card at each end, and carefully rock it back and forth until the connectors pull free from the socket.
  - d. Pull the expansion card straight up from the socket ❸. Be sure not to scrape the card against the expansion card assembly.

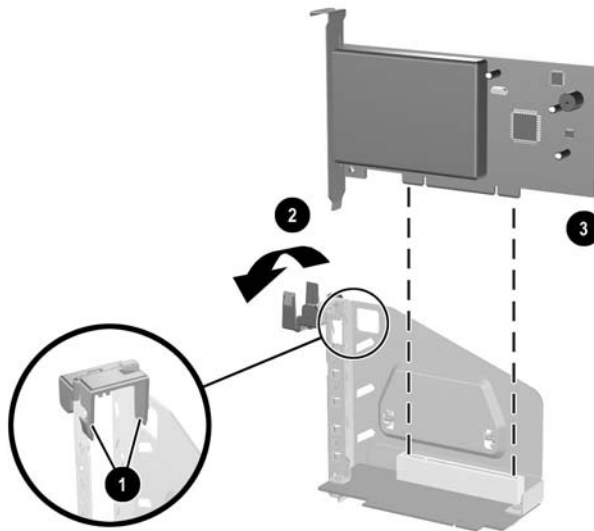

#### *Removing an Expansion Card*

8. Store the card in anti-static packaging.
9. If you are not installing a new expansion card, install an expansion slot cover to close the open slot or install the expansion card assembly without riser that shipped with the computer.



**CAUTION:** To insure proper cooling of internal components during operation after removing an expansion card, you must replace it with a new card, cover the open slot (for example, with a metal slot cover), or replace the expansion card assembly with the expansion card assembly without riser that shipped with the computer.

10. Replace the access panel.
11. Install the optional cable lock, if desired.
12. Replace the stand, if desired.
13. Reconnect all external devices, plug the power cord into the power outlet, and turn the computer on.
14. Use Computer Setup to enable the Smart Cover Sensor, if desired.

## Upgrading the Hard Drive

---



The Ultra-Slim Desktop supports only Serial ATA (SATA) internal hard drives; parallel ATA (PATA) internal hard drives are not supported.

Be sure to back up the data from the old hard drive before removing it so that you can transfer the data to the new hard drive.

---

The 3.5-inch hard drive is located on the left side of the computer, under the MultiBay.

1. If the Smart Cover Sensor is enabled, restart the computer and enter Computer Setup to disable it.
2. Turn off the computer properly through the operating system, then turn off any external devices.
3. Disconnect the power cord from the power outlet and the computer, and disconnect any external devices.
4. Position the computer on its side with the rubber pads on the bottom. (If the computer is being used in the tower configuration, remove the computer from the stand. Refer to [“Attaching and Removing the Tower Stand”](#) on page 2–7 for more information.)
5. Remove the access panel. Refer to [“Removing and Replacing the Access Panel”](#) on page 2–1 for more information.
6. Remove the front bezel and MultiBay. Refer to [“Removing and Replacing the Front Bezel and MultiBay”](#) on page 2–3 for more information.

7. Pull the hard drive latch toward the front of the computer ❶.
8. Rotate the right side of the hard drive up until it stops ❷, then pull the drive out to the right ❸.

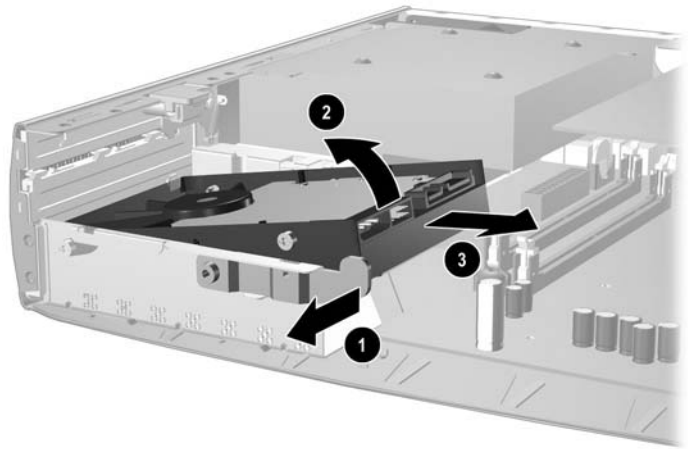

*Removing the Internal Hard Drive*



When removing cables, pull on the connector instead of the cable itself. This will help prevent cable damage.

---

9. Disconnect the data cable ❶ from the hard drive by pulling the connector out of the socket in the hard drive.
10. Disconnect the other end of the data cable from the system board.
11. Disconnect the power cable ❷ from the hard drive by pulling the connector out of the socket in the hard drive.

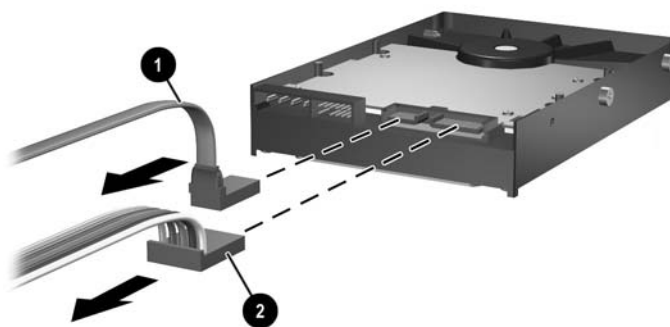

*Disconnecting the Data Cable and Power Cable from the Hard Drive*

12. Transfer the four screws from the old drive to the new one. The screws take the place of drive rails.



When transferring the screws, carefully note the position of the screws on the old drive. The screws must be transferred to the same position on the new drive.

---

13. Connect the data cable to the data connector on the system board.
14. Connect the data cable ❶ and power cable ❷ to the new hard drive.

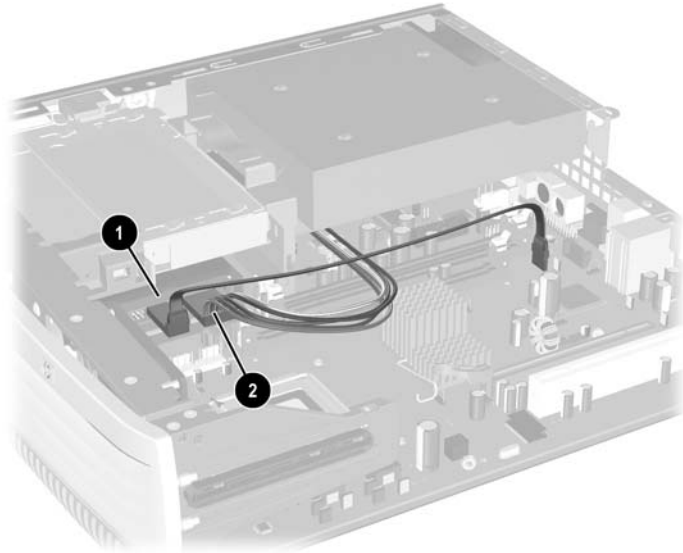

*Data ❶ and Power ❷ Cable Connector Locations*

15. Gently place the left side of the hard drive in place, then rotate the right side of the drive down until it locks.
16. Replace the front bezel and MultiBay assembly.
17. Replace the access panel.
18. Replace the stand, if desired.
19. Reconnect all external devices, plug the power cord into the power outlet, and turn the computer on.
20. Use Computer Setup to enable the Smart Cover Sensor, if desired.



---

No configuration of the SATA hard drive is necessary; the computer automatically recognizes it the next time you turn on the computer.

---



After replacing the hard drive, insert the *Restore Plus! CD* to restore the operating system, software drivers, and any software applications that were preinstalled on the computer. Follow the instructions in the guide included with the *Restore Plus! CD*. When the restore process has completed, install any personal files that you backed up before replacing the hard drive.

---

## Working with the MultiBay

The MultiBay is a special drive bay that supports a variety of optional 12.7-mm removable drives, including:

- MultiBay 1.44-MB Diskette Drive\*
- MultiBay CD-ROM Drive\*
- MultiBay CD-RW Drive
- MultiBay DVD-ROM Drive
- MultiBay CD-RW/DVD-ROM Combo Drive
- MultiBay SMART Hard Drive

\* Can be hot-plugged or hot-swapped



**CAUTION:** To prevent loss of work and damage to the computer or a drive:

- Before handling a drive, ensure that you are discharged of static electricity. While handling a drive, avoid touching the connector.
  - Before traveling with, shipping, storing, or removing a drive other than a hard drive, make sure that no media, such as a diskette, CD-ROM, or DVD-ROM, is in the drive and that the media tray is closed.
  - Handle a drive carefully: do not use excessive force when inserting it, do not drop it, and do not press on the top cover.
  - Avoid exposing a hard drive to liquids, temperature extremes, or products that have magnetic fields such as monitors or speakers.
  - If a drive must be mailed, place the drive in a bubble-pack mailer or other suitable protective packaging and label the package "Fragile: Handle with Care."
-

## “Hot-Plugging” or “Hot-Swapping” MultiBay Drives

---



**CAUTION:** To prevent damage to the computer, the drive, and any data stored on the drive: If you are inserting or removing a hard drive, shut down the computer. Never remove a hard drive while the computer is on or on standby. To ensure that the computer is not on standby, turn the computer on, then shut it down.

---

If the computer is running a preinstalled operating system supplied by HP, you can insert or remove a diskette drive or a CD-ROM drive while the computer is on, off, or on standby.

---



**CAUTION:** After inserting an optical drive while the computer is turned on, restart the computer to ensure the optical drive functions correctly if it uses recording, backup, or video playback software applications.

---

## Engaging and Releasing the MultiBay Security Catch

When engaged, the MultiBay security catch disables the MultiBay eject lever, so that a drive installed in the MultiBay cannot be removed.

To secure a drive in the MultiBay:

1. If the Smart Cover Sensor is enabled, restart the computer and enter Computer Setup to disable it.
2. Turn off the computer properly through the operating system, then turn off any external devices.
3. Disconnect the power cord from the power outlet and the computer, and disconnect any external devices.
4. Position the computer on its side with the rubber pads on the bottom. (If the computer is being used in the tower configuration, remove the computer from the stand. Refer to [“Attaching and Removing the Tower Stand”](#) on page 2–7 for more information.)
5. Remove the access panel. Refer to [“Removing and Replacing the Access Panel”](#) on page 2–1 for more information.

6. Rotate the catch toward the left side of the computer until it is engaged.

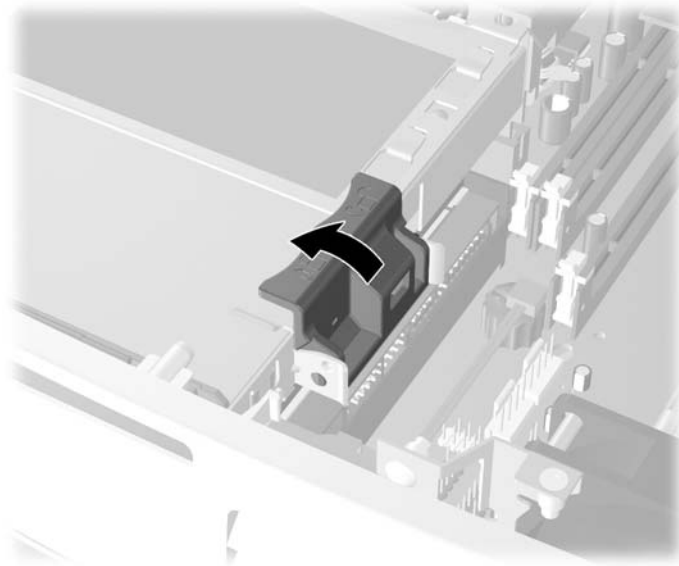

*Engaging the MultiBay Security Catch*

7. Replace the access panel.
8. Replace the stand, if desired.
9. Reconnect all external devices, plug the power cord into the power outlet, and turn the computer on.
10. Use Computer Setup to enable the Smart Cover Sensor, if desired.

To release the MultiBay security catch:

1. If the Smart Cover Sensor is enabled, restart the computer and enter Computer Setup to disable it.
2. Turn off the computer properly through the operating system, then turn off any external devices.
3. Disconnect the power cord from the power outlet and the computer, and disconnect any external devices.



4. Position the computer on its side with the rubber pads on the bottom. (If the computer is being used in the tower configuration, remove the computer from the stand. Refer to [“Attaching and Removing the Tower Stand”](#) on page 2-7 for more information.)
5. Remove the access panel. Refer to [“Removing and Replacing the Access Panel”](#) on page 2-1 for more information.
6. Rotate the catch toward the right side of the computer until it is disengaged.

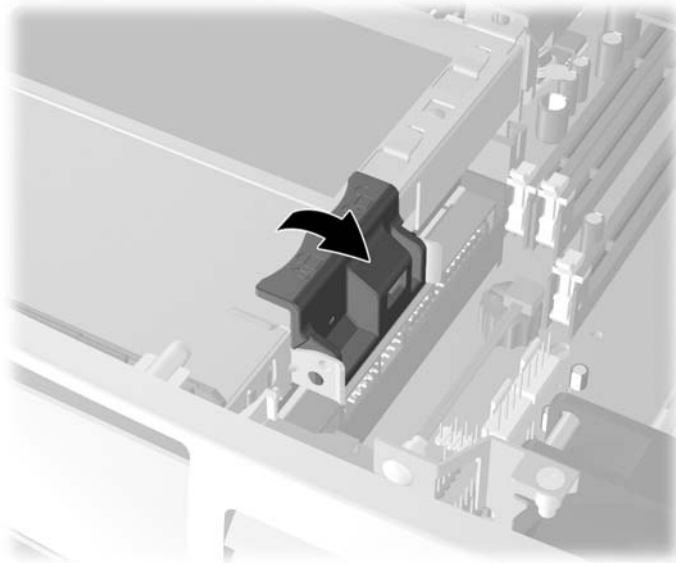

#### *Releasing the MultiBay Security Catch*

7. Replace the access panel.
8. Replace the stand, if desired.
9. Reconnect all external devices, plug the power cord into the power outlet, and turn the computer on.
10. Use Computer Setup to enable the Smart Cover Sensor, if desired.

## Removing a Drive from the MultiBay

1. Remove any removable media, such as a compact disc, from the drive.
2. Before removing an optical or diskette drive, stop the drive using the **Safely Remove Hardware** icon on the Windows task bar.
3. If you are not hot-swapping a CD-ROM or diskette drive, exit all software applications, shut down the operating system software, and turn off the computer.
4. Release the MultiBay security catch, if it has been engaged. Refer to [“Engaging and Releasing the MultiBay Security Catch”](#) on [page 2–29](#) for more information.
5. Slide the eject lever down (or towards the left of the computer, if the computer is in the desktop position) ❶ to eject the drive ❷ from the MultiBay.

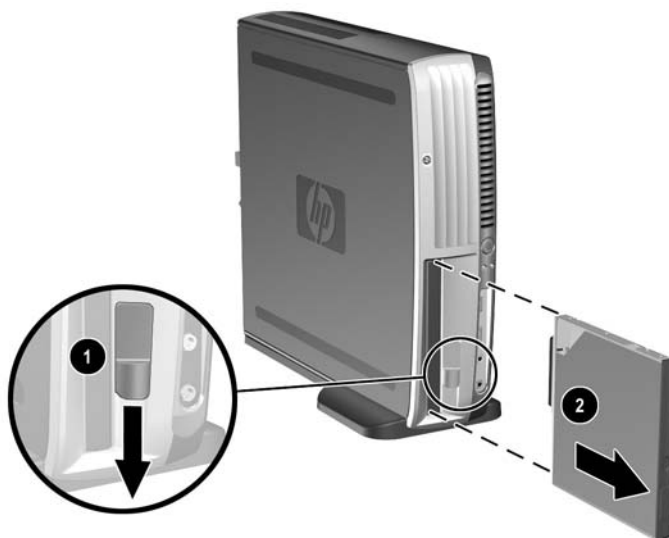

*Removing a Drive from the MultiBay (shown with USDT in tower configuration)*

## Inserting a Drive into the MultiBay

1. Remove any removable media, such as a compact disc, from the drive.
2. If you are not hot-swapping a CD-ROM or diskette drive, exit all software applications, shut down the operating system software, and turn off the computer.
3. With the top of the drive facing left (or up, when the computer is in the desktop position) and the drive connector facing the computer, slide the drive into the MultiBay and push firmly to ensure that the electrical connector is properly seated.

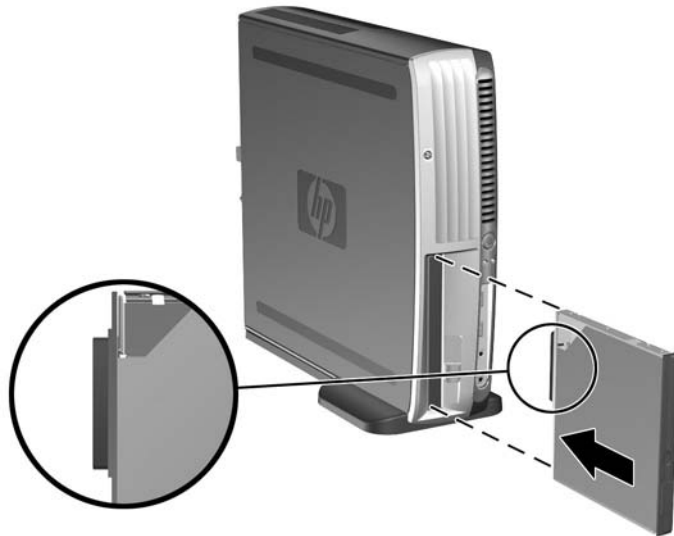

*Inserting a Drive into the MultiBay (shown with USDT in tower configuration)*

4. After inserting an optical drive while the computer is turned on, restart the computer to ensure the optical drive functions correctly if it uses recording, backup, or video playback software applications.
5. Engage the MultiBay security catch, if desired. Refer to [“Engaging and Releasing the MultiBay Security Catch”](#) on [page 2–29](#) for more information.

If the device does not start, ensure that the necessary device drivers are installed on the system. If they are not available, they may be downloaded, at no cost, from the HP Web site at [www.hp.com](http://www.hp.com). Click **support & drivers**, select **Download drivers and software**, enter the model number of the computer, and press **Enter**.

## Partitioning and Formatting a MultiBay Hard Drive

---



You must be logged on as an administrator or a member of the Administrators group in order to complete this procedure.

---

1. Exit all software applications, shut down the operating system software, and turn off the computer.
2. Insert the MultiBay hard drive into the MultiBay. Refer to [“Inserting a Drive into the MultiBay”](#) on page 2–33 for more information.
3. Turn on the computer.
4. Click **Start**.
5. Right-click **My Computer**, then click **Manage**.
6. Click **Storage**, then double-click **Disk Management**.
7. Right-click the MultiBay hard drive, then click **Partition**. Carefully read and respond to any prompts that appear on the screen.

Refer to the online Help (click **Action > Help**) for additional information.

---

## Specifications

### Ultra-Slim Desktop

---

#### Desktop Dimensions

(in the tower position)

Height	12.40 in	315 mm
Width	2.75 in	70 mm
Depth	13.18 in	335 mm

---

#### Approximate Weight

13.9 lb      6.3 kg

Weight Supported (maximum distributed load in desktop position)

77 lb      35 kg

---

**Temperature Range** (values subject to change with increasing altitude above sea level)

Operating	50° to 95° F	10° to 35° C
Nonoperating	-22° to 140° F	-30° to 60° C

---

 Operating temperature is derated 1.0° C per 300 m (1,000 ft) to 3,000 m (10,000 ft) above sea level, no direct sustained sunlight. Maximum rate of change is 10° C (50° F)/Hr. The upper limit may be limited by the type and number of options installed.

---

**Relative Humidity** (noncondensing)

Operating (28° C (82.4° F) max wet bulb)	10 to 90%
Nonoperating (38.7° C (101.66° F) max wet bulb)	5 to 95%

---

**Maximum Altitude** (unpressurized)

Operating	10,000 ft	3,048 m
Nonoperating	30,000 ft	9,144 m

---

**Ultra-Slim Desktop** (Continued)

---

**Mechanical Shock** (11ms 1/2 sine shock pulse)

Operating	5 Gs
Nonoperating	20 Gs

---

**Vibration** (random, Gs nominal)

Operating (10 to 300 Hz)	.25
Nonoperating (10 to 500 Hz)	.50

---

**Power Supply**

Operating Voltage Range	90 to 264 VAC	90 to 264 VAC
Rated Voltage Range*	100 to 240 VAC	100 to 240 VAC
Rated Line Frequency	50 to 60 Hz	50 to 60 Hz

---

**Power Output** 200 W

---

**Rated Input Current (maximum)\***

4 A	2 A
(@ 100 VAC)	(@ 200 VAC)

---

**Heat Dissipation**

Maximum	1050 BTU/hr	265 kg-cal/hr
Typical (idle)	341 BTU/hr	86 kg-cal/hr

---

\*This system uses an active power factor corrected power supply. This allows the system to pass the CE mark requirements for use in the countries of the European Union. The active power factor corrected power supply also has the added benefit of not requiring an input voltage range select switch.

---

---

## Battery Replacement

The battery that comes with the computer provides power to the real-time clock. When replacing the battery, use a battery equivalent to the battery originally installed in the computer. The computer comes with a 3-volt lithium coin cell battery.



The lifetime of the lithium battery can be extended by plugging the computer into a live AC wall socket. The lithium battery is only used when the computer is NOT connected to AC power.

---



**WARNING:** The computer contains an internal lithium manganese dioxide battery. There is a risk of fire and burns if the battery is not handled properly. To reduce the risk of personal injury:

- Do not attempt to recharge the battery.
  - Do not expose to temperatures higher than 60° C (140° F).
  - Do not disassemble, crush, puncture, short external contacts, or dispose of in fire or water.
  - Replace the battery only with the HP spare designated for this product.
- 



**CAUTION:** Before replacing the battery, it is important to back up the computer CMOS settings. When the battery is removed or replaced, the CMOS settings will be cleared. Refer to the *Computer Setup (F10) Utility Guide* on the *Documentation and Diagnostics* CD for information on backing up the CMOS settings.

---



Batteries, battery packs, and accumulators should not be disposed of together with the general household waste. In order to forward them to recycling or proper disposal, please use the public collection system or return them to HP, their authorized partners, or their agents.

---



**CAUTION:** Static electricity can damage the electronic components of the computer or optional equipment. Before beginning these procedures, ensure that you are discharged of static electricity by briefly touching a grounded metal object.

---

1. Use Computer Setup to disable the Smart Cover Sensor, if necessary. Refer to the *Computer Setup (F10) Utility Guide* on the *Documentation and Diagnostics* CD for more information.
2. Remove the drive from the MultiBay. Refer to “[Removing a Drive from the MultiBay](#)” on page 2–32 for more information.
3. Turn off the computer properly through the operating system, then turn off any external devices. Disconnect the power cord from the power outlet and disconnect any external devices.
4. Remove the computer access panel. Refer to “[Removing and Replacing the Access Panel](#)” on page 2–1 for more information.
5. Remove the MultiBay daughter card by pulling it straight up out of the computer ❶.
6. Pull the power supply forward ❷, then rotate the right side up ❸.
7. Pull the power supply out of the computer.

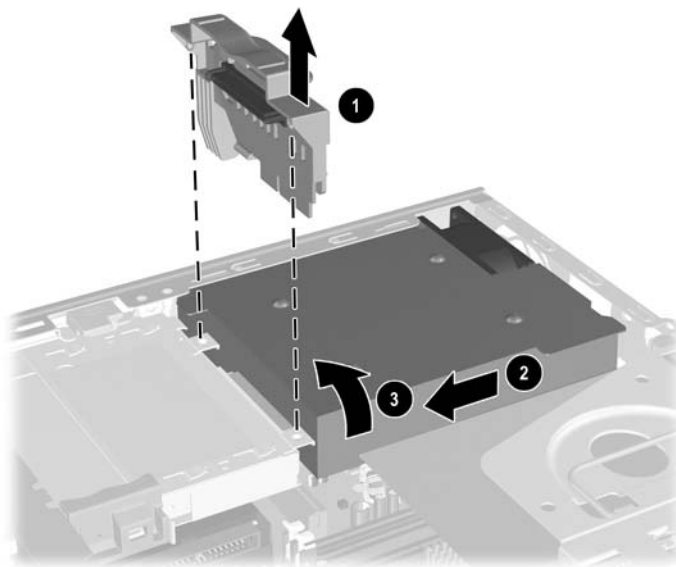

*Removing the Power Supply*



8. Locate the battery and battery holder on the system board.
9. Release the battery latch and lift the battery out of the holder ❶.
10. Holding the replacement battery with the positive side up, push the battery down until the latch snaps over the upper edge of the battery ❷.

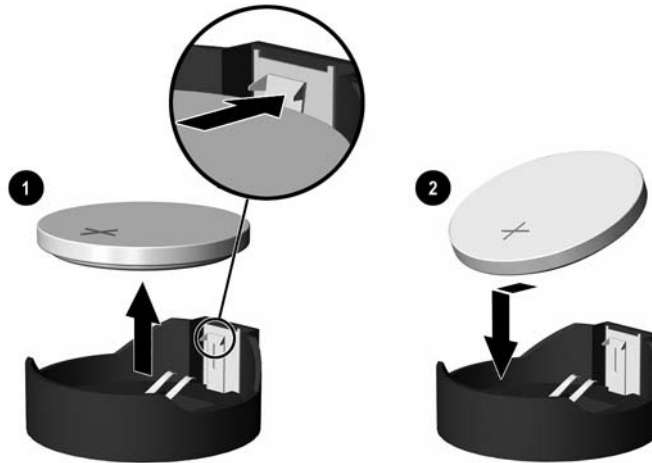

### *Replacing the Battery*



After the battery has been replaced, use the following steps to complete this procedure.

11. Replace the power supply:
  - a. Gently place the left side of the power supply in place.
  - a. Rotate the right side of the power supply down until it stops.
  - b. Slide the power supply back until it locks in place.
12. Replace the MultiBay daughter card by carefully aligning the card with the connector slot and pressing the card firmly into place.
13. Replace the MultiBay drive.

14. Engage the MultiBay security catch, if desired.
15. Replace the computer access panel.
16. Reconnect all external devices, plug the power cord into the power outlet, and turn the computer on.
17. Using Computer Setup:
  - a. Reset the date and time.
  - b. Reset your passwords.
  - c. Reset any special system setups.
  - d. Enable the Smart Cover Sensor, if necessary.

Refer to the *Computer Setup (F10) Utility Guide* on the *Documentation and Diagnostics CD* for more information.

---

## Security Provisions



---

For information on data security features, refer to the *Computer Setup (F10) Utility Guide* and the *Desktop Management Guide* on the *Documentation and Diagnostics CD* and the *HP ProtectTools Security Manager Guide* (some models) at [www.hp.com](http://www.hp.com).

---

### Installing an Optional Security Lock

The security locks displayed below and on the following pages can be used to secure the Ultra-Slim Desktop.

#### Cable Lock



*Installing a Cable Lock*

## Padlock



*Installing a Padlock*

## Universal Chassis Clamp Lock

### Without Security Cable

1. Thread the keyboard and mouse cables through the lock.



2. Screw the lock to the chassis using the screw provided.

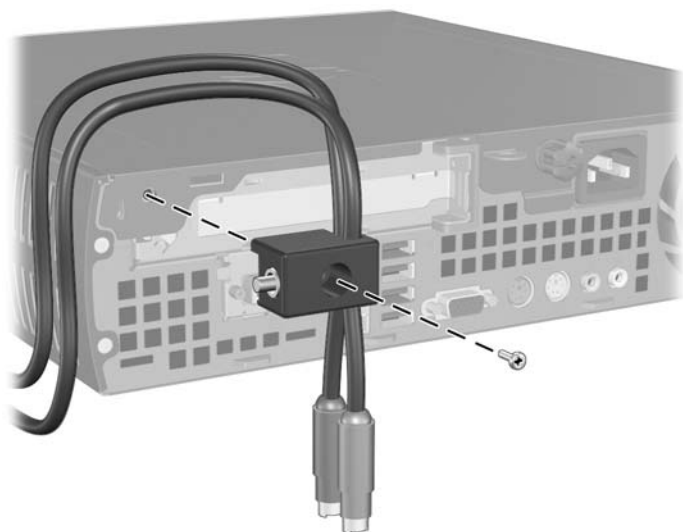

3. Insert the plug into the lock ❶ and push the button ❷ in to engage the lock. Use the key provided to disengage the lock.

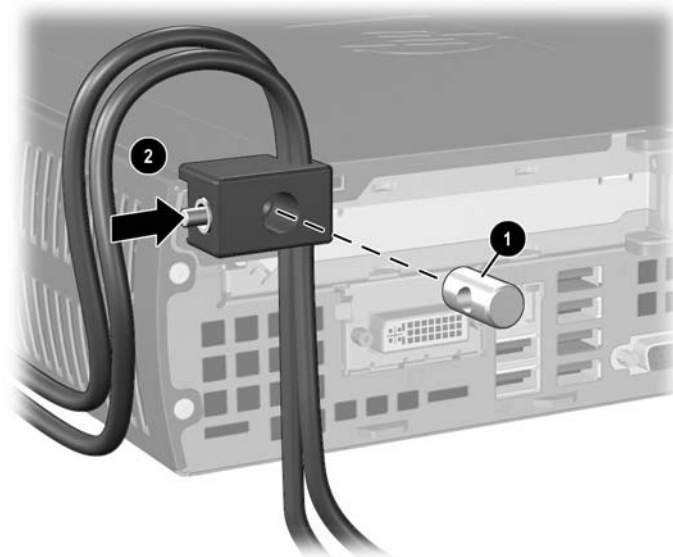

## With Security Cable

1. Fasten the security cable by looping it around a stationary object.



2. Thread the keyboard and mouse cables through the lock.



3. Screw the lock to the chassis using the screw provided.

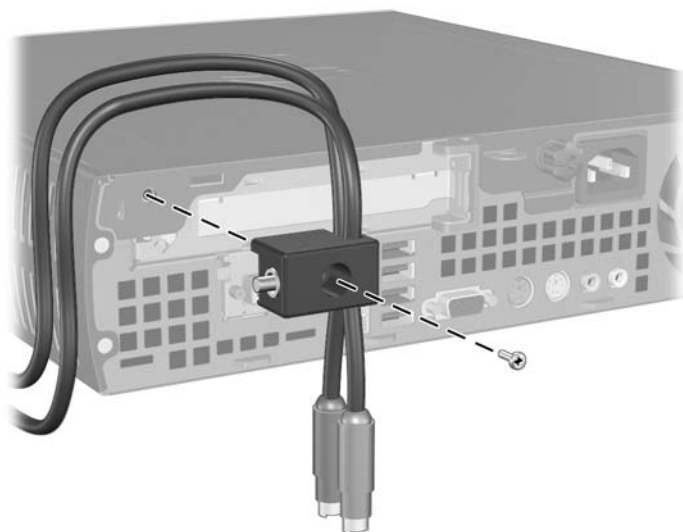

4. Insert the plug end of the security cable into the lock ❶ and push the button in to engage the lock ❷. Use the key provided to disengage the lock.

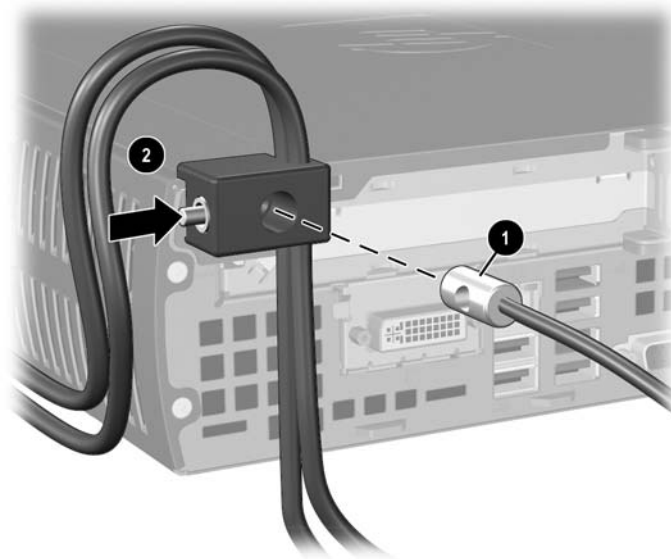



---

## Electrostatic Discharge

A discharge of static electricity from a finger or other conductor may damage system boards or other static-sensitive devices. This type of damage may reduce the life expectancy of the device.

### Preventing Electrostatic Damage

To prevent electrostatic damage, observe the following precautions:

- Avoid hand contact by transporting and storing products in static-safe containers.
- Keep electrostatic-sensitive parts in their containers until they arrive at static-free workstations.
- Place parts on a grounded surface before removing them from their containers.
- Avoid touching pins, leads, or circuitry.
- Always be properly grounded when touching a static-sensitive component or assembly.

### Grounding Methods

There are several methods for grounding. Use one or more of the following methods when handling or installing electrostatic-sensitive parts:

- Use a wrist strap connected by a ground cord to a grounded workstation or computer chassis. Wrist straps are flexible straps with a minimum of 1 megohm  $\pm$ 10 percent resistance in the ground cords. To provide proper ground, wear the strap snug against the skin.

- Use heelstraps, toestraps, or bootstraps at standing workstations. Wear the straps on both feet when standing on conductive floors or dissipating floor mats.
- Use conductive field service tools.
- Use a portable field service kit with a folding static-dissipating work mat.

If you do not have any of the suggested equipment for proper grounding, contact an authorized dealer, reseller, or service provider.

---



For more information on static electricity, contact an authorized dealer, reseller, or service provider.

---

---

## Computer Operating Guidelines, Routine Care and Shipping Preparation

### Computer Operating Guidelines and Routine Care

Follow these guidelines to properly set up and care for the computer and monitor:

- Keep the computer away from excessive moisture, direct sunlight, and extremes of heat and cold. For information about the recommended temperature and humidity ranges for the computer, refer to [Appendix A, “Specifications”](#) in this guide.
- Operate the computer on a sturdy, level surface. Leave a 10.2-cm (4-inch) clearance on all vented sides of the computer and above the monitor to permit the required airflow.
- Never restrict the airflow into the computer by blocking any vents or air intakes. Do not place the keyboard, with the keyboard feet down, directly against the front of the desktop unit as this also restricts airflow.
- Never operate the computer with the cover or side panel removed.
- Do not stack computers on top of each other or place computers so near each other that they are subject to each other’s re-circulated or preheated air.
- If the computer is to be operated within a separate enclosure, intake and exhaust ventilation must be provided on the enclosure, and the same operating guidelines listed above will still apply.
- Keep liquids away from the computer and keyboard.
- Never cover the ventilation slots on the monitor with any type of material.
- Install or enable power management functions of the operating system or other software, including sleep states.

- Turn off the computer before you do either of the following:
  - Wipe the exterior of the computer with a soft, damp cloth as needed. Using cleaning products may discolor or damage the finish.
  - Occasionally clean the air vents on all vented sides of the computer. Lint, dust, and other foreign matter can block the vents and limit the airflow.

## Optical Drive Precautions

Be sure to observe the following guidelines while operating or cleaning the optical drive.

### Operation

- Do not move the drive during operation. This may cause it to malfunction during reading.
- Avoid exposing the drive to sudden changes in temperature, as condensation may form inside the unit. If the temperature suddenly changes while the drive is on, wait at least one hour before you turn off the power. If you operate the unit immediately, it may malfunction while reading.
- Avoid placing the drive in a location that is subject to high humidity, extreme temperatures, mechanical vibration, or direct sunlight.

### Cleaning

- Clean the panel and controls with a soft, dry cloth or a soft cloth lightly moistened with a mild detergent solution. Never spray cleaning fluids directly on the unit.
- Avoid using any type of solvent, such as alcohol or benzene, which may damage the finish.

### Safety

If any object or liquid falls into the drive, immediately unplug the computer and have it checked by an authorized HP service provider.

## Shipping Preparation

Follow these suggestions when preparing to ship the computer:

1. Back up the hard drive files on PD discs, tape cartridges, CDs, or diskettes. Be sure that the backup media is not exposed to electrical or magnetic impulses while stored or in transit.



The hard drive locks automatically when the system power is turned off.

---

2. Remove and store any program diskettes from the diskette drives.
3. Insert a blank diskette into the diskette drive to protect the drive while in transit. Do not use a diskette on which you have stored or plan to store data.
4. Turn off the computer and external devices.
5. Disconnect the power cord from the electrical outlet, then from the computer.
6. Disconnect the system components and external devices from their power sources, then from the computer.



Ensure that all boards are seated properly and secured in the board slots before shipping the computer.

---

7. Pack the system components and external devices in their original packing boxes or similar packaging with sufficient packing material to protect them.



For environmental nonoperating ranges, see [Appendix A, “Specifications”](#) in this guide.

---



---

# Index

## A

- access panel
  - removal of 2-1 to 2-2
- audio connector 1-3

## B

- battery replacement B-1

## C

- cable connectors, hard drive 2-27
- cable lock, optional C-1
- CD drive, MultiBay 2-28
- components
  - front panel 1-2
  - rear panel 1-3
- computer
  - operating guidelines E-1
  - shipping preparation E-3
- configuration
  - desktop 1-6
- configuration, tower or desktop 1-6
- connectors, hard drive 2-27

## D

- desktop configuration 1-6
- DIMM, adding system memory 2-11 to 2-17
- diskette drive, MultiBay 2-28, 2-32
- drives, MultiBay 2-28
- DVD drive, MultiBay 2-28
- DVI-D monitor connector 1-3

## E

- electrostatic discharge D-1

## expansion card

- FireWire 2-17
- graphics 2-17
- installing 2-17 to 2-21
- modem 2-17
- NIC 2-17
- removing 2-22 to 2-24
- wireless LAN 2-17

## F

- FireWire, PCI expansion card 2-17
- formatting MultiBay hard drive 2-34
- front panel components 1-2

## G

- graphics, PCI expansion card 2-17
- grounding methods D-1

## H

- hard drive
  - internal, removing and replacing 2-24 to 2-27
  - MultiBay 2-28, 2-33, 2-34
    - partitioning and formatting 2-34
    - restoring 2-28
- headphone line-out connector 1-3
- hot-plugging or hot-swapping MultiBay drives 2-29

## I

### installing

- hard drives, MultiBay 2-33 to 2-34
- internal hard drive 2-24 to 2-27
- MultiBay drives 2-33 to 2-34
- optical drive 2-29
- PCI expansion card 2-17 to 2-21

### internal hard drive, upgrading 2-24 to 2-27

## K

### keyboard 1-4

- PS/2 port 1-3
- Windows Logo Key 1-5

## L

### locks

- cable C-1
- padlock C-2

## M

### memory, system 2-11 to 2-17

- adding or removing modules 2-14 to 2-17

### modem, PCI expansion card 2-17

### monitor connector 1-3

- DVI-D 1-3

### mouse

- PS/2 connector 1-3

### MPEG-2 software 2-28

### MultiBay 2-28 to 2-32

- CD drives 2-28
- CD-RW/DVD-ROM combo drive 2-28
- diskette drive 2-28, 2-32
- DVD drive 2-28
- hard drive 2-33
- hot-plugging or hot-swapping drives 2-29
- inserting drives 2-33
- MPEG-2 software 2-28
- optical drive 2-29, 2-32
- optional drives 2-28
- partitioning and formatting hard drive 2-34
- precautions 2-28
- removing drives 2-32
- security 2-29 to 2-31

## N

### NIC, PCI expansion card 2-17

## O

### optical drive, MultiBay 2-29, 2-32

### overheating, prevention of 1-6

## P

### padlock, optional C-2

### panel

- removal of access 2-1 to 2-2

### parallel connector 1-3

### partitioning MultiBay hard drive 2-34

### PCI expansion card

- FireWire 2-17
- graphics 2-17
- installing 2-17 to 2-21
- modem 2-17
- NIC 2-17
- removing 2-22 to 2-24
- wireless LAN 2-17

### power

- cord connector 1-3



## **R**

rear panel components 1–3  
removing  
    PCI expansion card 2–22 to 2–24  
RJ-45 connector 1–3

## **S**

security C–1  
    MultiBay 2–29 to 2–31  
serial connector 1–3  
serial number 1–6  
shipping preparation E–3  
specifications A–1  
static electricity D–1  
SuperDisk LS-240 drive, MultiBay 2–28

## **T**

tower configuration 1–6

## **U**

USB 1–3

## **W**

Windows Logo Key 1–5  
wireless LAN, PCI expansion card 2–17

