

P9D-E/4L

ASUS[®]

Motherboard

E7867
First Edition
May 2013

Copyright © 2013 ASUSTeK COMPUTER INC. All Rights Reserved.

No part of this manual, including the products and software described in it, may be reproduced, transmitted, transcribed, stored in a retrieval system, or translated into any language in any form or by any means, except documentation kept by the purchaser for backup purposes, without the express written permission of ASUSTeK COMPUTER INC. ("ASUS").

Product warranty or service will not be extended if: (1) the product is repaired, modified or altered, unless such repair, modification or alteration is authorized in writing by ASUS; or (2) the serial number of the product is defaced or missing.

ASUS PROVIDES THIS MANUAL "AS IS" WITHOUT WARRANTY OF ANY KIND, EITHER EXPRESS OR IMPLIED, INCLUDING BUT NOT LIMITED TO THE IMPLIED WARRANTIES OR CONDITIONS OF MERCHANTABILITY OR FITNESS FOR A PARTICULAR PURPOSE. IN NO EVENT SHALL ASUS, ITS DIRECTORS, OFFICERS, EMPLOYEES OR AGENTS BE LIABLE FOR ANY INDIRECT, SPECIAL, INCIDENTAL, OR CONSEQUENTIAL DAMAGES (INCLUDING DAMAGES FOR LOSS OF PROFITS, LOSS OF BUSINESS, LOSS OF USE OR DATA, INTERRUPTION OF BUSINESS AND THE LIKE), EVEN IF ASUS HAS BEEN ADVISED OF THE POSSIBILITY OF SUCH DAMAGES ARISING FROM ANY DEFECT OR ERROR IN THIS MANUAL OR PRODUCT.

SPECIFICATIONS AND INFORMATION CONTAINED IN THIS MANUAL ARE FURNISHED FOR INFORMATIONAL USE ONLY, AND ARE SUBJECT TO CHANGE AT ANY TIME WITHOUT NOTICE, AND SHOULD NOT BE CONSTRUED AS A COMMITMENT BY ASUS. ASUS ASSUMES NO RESPONSIBILITY OR LIABILITY FOR ANY ERRORS OR INACCURACIES THAT MAY APPEAR IN THIS MANUAL, INCLUDING THE PRODUCTS AND SOFTWARE DESCRIBED IN IT.

Products and corporate names appearing in this manual may or may not be registered trademarks or copyrights of their respective companies, and are used only for identification or explanation and to the owners' benefit, without intent to infringe.

Contents

Notices	vii
Federal Communications Commission Statement	vii
Canadian Department of Communications Statement	vii
REACH	vii
Safety information	viii
Electrical safety	viii
Operation safety	viii
Australia statement notice	ix
About this guide	x
How this guide is organized	x
Where to find more information	x
P9D-E/4L Specifications Summary	xii
Chapter 1: Product Introduction	
1.1 Welcome!	1-3
1.2 Package contents	1-3
1.3 Serial number label	1-4
1.4 Special features	1-4
1.4.1 Product highlights	1-4
1.4.2 Innovative ASUS features	1-6
Chapter 2: Hardware Information	
2.1 Before you proceed	2-3
2.2 Motherboard overview	2-4
2.2.1 Placement direction	2-4
2.2.2 Screw holes	2-4
2.2.3 Motherboard layout	2-5
2.2.4 Layout contents	2-6
2.3 Central Processing Unit (CPU)	2-8
2.3.1 Installing the CPU	2-8
2.3.2 Installing the CPU heatsink	2-11
2.3.3 Uninstalling the CPU heatsink and fan	2-12
2.3.4 Installing the CPU heatsink in rack	2-13
2.4 System memory	2-14
2.4.1 Overview	2-14
2.4.2 Memory Configurations	2-14
2.4.3 Installing a DIMM on a single clip DIMM socket	2-15

Contents

2.5	Expansion slots.....	2-16
2.5.1	Installing an expansion card.....	2-16
2.5.2	Configuring an expansion card	2-16
2.5.3	Interrupt assignments.....	2-17
2.5.4	PCI Express x16 slot (x16 link)	2-17
2.5.5	PCI Express x8 slot (x8 link)	2-17
2.5.6	PCI Express x1 slot (x1 link)	2-17
2.5.7	PCI slot	2-17
2.5.8	PIKE slot	2-18
2.5.9	Installing the ASUS PIKE RAID card.....	2-19
2.5.10	Installing the Baseboard Management Card.....	2-20
2.5.11	Connecting the Thermal sensor cable	2-21
2.5.12	Installing the Audio card.....	2-22
2.6	Onboard LEDs.....	2-23
2.7	Jumpers	2-26
2.8	Connectors	2-29
2.8.1	Rear panel connectors.....	2-29
2.8.2	Internal connectors.....	2-30

Chapter 3: Powering Up

3.1	Starting up for the first time.....	3-3
3.2	Powering off the computer.....	3-4
3.2.1	Using the OS shut down function.....	3-4
3.2.2	Using the dual function power switch.....	3-4

Chapter 4: BIOS setup 4-1

4.1	Managing and updating your BIOS	4-3
4.1.1	ASUS CrashFree BIOS 3 utility.....	4-3
4.1.2	ASUS EzFlash Utility.....	4-4
4.1.3	BUPDATER utility.....	4-5
4.2	BIOS setup program	4-7
4.2.1	BIOS menu screen.....	4-8
4.2.2	Menu bar	4-8
4.2.3	Menu items.....	4-9
4.2.4	Submenu items	4-9
4.2.5	Navigation keys.....	4-9
4.2.6	General help.....	4-9
4.2.7	Configuration fields	4-9
4.2.8	Pop-up window.....	4-9
4.2.9	Scroll bar	4-9

Contents

4.3	Main menu	4-10
4.3.1	System Date	4-10
4.3.2	System Time	4-10
4.4	Advanced menu	4-11
4.4.1	CPU Configuration	4-12
4.4.2	PCH-IO Configuration	4-15
4.4.3	SATA Configuration	4-16
4.4.4	System Agent (SA) Configuration	4-17
4.4.5	PCI Subsystem Settings	4-19
4.4.6	USB Configuration	4-21
4.4.7	TPM.....	4-22
4.4.8	ACPI Settings.....	4-22
4.4.9	WHEA Support.....	4-23
4.4.10	NCT6779D Super IO Configuration	4-23
4.4.11	Intel Server Platform Services.....	4-24
4.4.12	Onboard LAN Configuration.....	4-25
4.4.13	MIO Card Configuration	4-25
4.4.14	Serial Port Console Redirection	4-26
4.4.15	Runtime Error Logging Support	4-29
4.4.16	APM	4-29
4.4.17	Network Stack.....	4-30
4.4.18	Intel RC Drivers Version Detail.....	4-30
4.5	Event Logs menu	4-31
4.6	Boot menu	4-32
4.7	Monitor menu	4-35
4.8	Security	4-36
4.9	Tool menu	4-39
4.10	Exit menu	4-39
 Chapter 5: RAID Configuration		
5.1	Setting up RAID	5-3
5.1.1	RAID definitions	5-3
5.1.2	Installing hard disk drives.....	5-4
5.1.3	Setting Jumpers	5-4
5.1.4	Setting the RAID mode in BIOS.....	5-4
5.1.5	RAID configuration utilities.....	5-4

Contents

- 5.2 **Intel® Rapid Storage Technology enterprise**
 - SATA Option ROM Utility 5-5**
 - 5.2.1 Creating a RAID set 5-6
 - 5.2.2 Deleting a RAID set 5-8
 - 5.2.3 Resetting disks to Non-RAID 5-9
 - 5.2.4 Exiting the Intel® Rapid Storage Technology enterprise
 - SATA Option ROM utility 5-10
 - 5.2.5 Rebuilding the RAID 5-10
 - 5.2.6 Setting the Boot array in the BIOS Setup Utility 5-12
- 5.3 **Intel® Rapid Storage Technology enterprise (Windows) 5-13**
 - 5.3.1 Creating a RAID set 5-14
 - 5.3.2 Changing a Volume Type 5-16
 - 5.3.3 Deleting a volume 5-17
 - 5.3.4 Preferences 5-18
- Chapter 6: Driver installation 6-1**
 - 6.1 **RAID driver installation 6-3**
 - 6.1.1 Creating a RAID driver disk 6-3
 - 6.1.2 Installing the RAID controller driver 6-5
 - 6.2 **Management applications and utilities installation 6-7**
 - 6.3 **Running the Support DVD 6-7**
 - 6.4 **Installing the LAN driver 6-15**
 - 6.5 **Installing the VGA driver 6-20**
 - 6.6 **Installing the Intel® C22x MEI NULL HECI driver 6-23**
 - 6.7 **Installing the Intel® I210 Gigabit Adapter driver 6-25**
- Appendix A: Reference Information**
 - A.1 **P9D-E/4L block diagram A-3**
 - ASUS contact information 1**

Notices

Federal Communications Commission Statement

This device complies with Part 15 of the FCC Rules. Operation is subject to the following two conditions:

- This device may not cause harmful interference, and
- This device must accept any interference received including interference that may cause undesired operation.

This equipment has been tested and found to comply with the limits for a Class B digital device, pursuant to Part 15 of the FCC Rules. These limits are designed to provide reasonable protection against harmful interference in a residential installation. This equipment generates, uses and can radiate radio frequency energy and, if not installed and used in accordance with manufacturer's instructions, may cause harmful interference to radio communications. However, there is no guarantee that interference will not occur in a particular installation. If this equipment does cause harmful interference to radio or television reception, which can be determined by turning the equipment off and on, the user is encouraged to try to correct the interference by one or more of the following measures:

- Reorient or relocate the receiving antenna.
- Increase the separation between the equipment and receiver.
- Connect the equipment to an outlet on a circuit different from that to which the receiver is connected.
- Consult the dealer or an experienced radio/TV technician for help.



The use of shielded cables for connection of the monitor to the graphics card is required to assure compliance with FCC regulations. Changes or modifications to this unit not expressly approved by the party responsible for compliance could void the user's authority to operate this equipment.

Canadian Department of Communications Statement

This digital apparatus does not exceed the Class B limits for radio noise emissions from digital apparatus set out in the Radio Interference Regulations of the Canadian Department of Communications.

This class B digital apparatus complies with Canadian ICES-003.

REACH

Complying with the REACH (Registration, Evaluation, Authorization, and Restriction of Chemicals) regulatory framework, we publish the chemical substances in our products at ASUS REACH website at <http://csr.asus.com/english/REACH.htm>.

Safety information

Electrical safety

- To prevent electrical shock hazard, disconnect the power cable from the electrical outlet before relocating the system.
- When adding or removing devices to or from the system, ensure that the power cables for the devices are unplugged before the signal cables are connected. If possible, disconnect all power cables from the existing system before you add a device.
- Before connecting or removing signal cables from the motherboard, ensure that all power cables are unplugged.
- Seek professional assistance before using an adapter or extension cord. These devices could interrupt the grounding circuit.
- Make sure that your power supply is set to the correct voltage in your area. If you are not sure about the voltage of the electrical outlet you are using, contact your local power company.
- If the power supply is broken, do not try to fix it by yourself. Contact a qualified service technician or your retailer.

Operation safety

- Before installing the motherboard and adding devices on it, carefully read all the manuals that came with the package.
- Before using the product, make sure all cables are correctly connected and the power cables are not damaged. If you detect any damage, contact your dealer immediately.
- To avoid short circuits, keep paper clips, screws, and staples away from connectors, slots, sockets and circuitry.
- Avoid dust, humidity, and temperature extremes. Do not place the product in any area where it may become wet.
- Place the product on a stable surface.
- If you encounter technical problems with the product, contact a qualified service technician or your retailer.



DO NOT throw the motherboard in municipal waste. This product has been designed to enable proper reuse of parts and recycling. This symbol of the crossed out wheeled bin indicates that the product (electrical and electronic equipment) should not be placed in municipal waste. Check local regulations for disposal of electronic products.



DO NOT throw the mercury-containing button cell battery in municipal waste. This symbol of the crossed out wheeled bin indicates that the battery should not be placed in municipal waste.

Australia statement notice

From 1 January 2012 updated warranties apply to all ASUS products, consistent with the Australian Consumer Law. For the latest product warranty details please visit <http://support.asus.com>. Our goods come with guarantees that cannot be excluded under the Australian Consumer Law. You are entitled to a replacement or refund for a major failure and compensation for any other reasonably foreseeable loss or damage. You are also entitled to have the goods repaired or replaced if the goods fail to be of acceptable quality and the failure does not amount to a major failure.

If you require assistance please call ASUS Customer Service 1300 2787 88 or visit us at <http://support.asus.com>

About this guide

This user guide contains the information you need when installing and configuring the motherboard.

How this guide is organized

This user guide contains the following parts:

- **Chapter 1: Product introduction**
This chapter describes the features of the motherboard and the new technologies it supports.
- **Chapter 2: Hardware information**
This chapter lists the hardware setup procedures that you have to perform when installing system components. It includes description of the switches, jumpers, and connectors on the motherboard.
- **Chapter 3: Powering up**
This chapter describes the power up sequence and ways of shutting down the system.
- **Chapter 4: BIOS setup**
This chapter tells how to change system settings through the BIOS Setup menus. Detailed descriptions of the BIOS parameters are also provided.
- **Chapter 5: RAID configuration**
This chapter provides instructions for setting up, creating, and configuring RAID sets using the available utilities.
- **Chapter 6: Driver installation**
This chapter provides instructions for installing the necessary drivers for different system components.
- **Appendix: Reference information**
This appendix includes additional information that you may refer to when configuring the motherboard.

Where to find more information

Refer to the following sources for additional information and for product and software updates.

1. **ASUS websites**
The ASUS website provides updated information on ASUS hardware and software products. Refer to the ASUS contact information.
2. **Optional documentation**
Your product package may include optional documentation, such as warranty flyers, that may have been added by your dealer. These documents are not part of the standard package.

Conventions used in this guide

To ensure that you perform certain tasks properly, take note of the following symbols used throughout this manual.



DANGER/WARNING: Information to prevent injury to yourself when trying to complete a task.



CAUTION: Information to prevent damage to the components when trying to complete a task.



IMPORTANT: Instructions that you **MUST** follow to complete a task.



NOTE: Tips and additional information to help you complete a task.

Typography

Bold text

Indicates a menu or an item to select.

Italics

Used to emphasize a word or a phrase.

<Key>

Keys enclosed in the less-than and greater-than sign means that you must press the enclosed key.

Example: <Enter> means that you must press the Enter or Return key.

<Key1> + <Key2> + <Key3>

If you must press two or more keys simultaneously, the key names are linked with a plus sign (+).

Example: <Ctrl> + <Alt> +

Command

Means that you must type the command exactly as shown, then supply the required item or value enclosed in brackets.

Example: At DOS prompt, type the command line:

format A: /S

P9D-E/4L Specifications Summary

Processor Support / System Bus		1 x Socket LGA1150 Intel® Xeon® Processor E3-1200 v3 Product Family Intel® Core™ i3 Processor Family*
Core Logic		Intel® C224 Chipset
Form Factor		ATX, 12 in. x 9.6 in.
ASUS Features	Fan Speed Control	✓
	Rack Ready (Rack and Pedestal dual use)	✓
	ASWM Enterprise	✓
Memory	Total Slots	4 (2 Channels)
	Capacity	Maximum up to 32GB
	Memory Type	DDR3 1333/1600 ECC UDIMM
Expansion Slots (follow SSI Location number)	Total PCI/PCI-E Slots	7
	Slot Location 1	1 x PCI 32bit/33 MHz
	Slot Location 2	1 x PCI 32bit/33 MHz
	Slot Location 3	1 x PCI-E x1 (x1 Gen2 link)
	Slot Location 4	1 x PCI-E x8 (x8 Gen3 link)
	Slot Location 5	1 x PCI-E x8 (x8 Gen3 link)
	Slot Location 6	1 x PCI-E x16 (x16 Gen3 link) (Auto switch to x8 link if slot 5 is occupied)
	Slot Location 7	1 x PCI-E x1 (x1 Gen2 link); MIO supported
	Additional Slot 1	1 x PIKE Slot for Storage expansion (Gen3 supported)
Storage	SATA Controller	Intel® C224: - 2 x SATA 3Gb/s ports - 4 x SATA 6Gb/s ports - Intel® Rapid Storage Technology Enterprise (RSTe) supports software RAID 0, 1, 10, & 5 (Windows)
	SAS Controller	Optional: ASUS PIKE 2008 8-port SAS 6G RAID card ASUS PIKE 2008/IMR 8-port SAS 6G RAID card ASUS PIKE 2108 8-port SAS 6G HW RAID card ASUS PIKE 2208 8-port SAS 6G HW RAID card ASUS PIKE 2308 8-port SAS 6G RAID card ASUS PIKE 9230 4-port SATA 6G RAID card

* Refer to www.asus.com for the complete list of supported CPUs.

(continued on the next page)

Networking	LAN	4 x Intel® I210AT 1 x Management LAN
Graphic	VGA	Aspeed AST2300 + 32MB VRAM
Onboard I/O Connectors	TPM Header	1
	PSU Connector	24-pin ATX power connector 8-pin ATX 12V power connector
	SATA DOM Power Connector	4-pin power connector
	Management Header	On-board header for optional management card
	USB Connector/ Header	1 x USB 3.0 pin header (up to 2 devices) 1 x USB 2.0 pin header (up to 2 devices) 1 x USB 2.0 connector (Type aA USB socket)
	Fan Header	5 x 4 pin headers
	SMBus	1
	Chassis Intruder	1
	Front LAN LED	4
	Serial Port Header	2
Rear I/O Connectors	VGA Header	1
	External USB Port	2 x USB 3.0 2 x USB 2.0
	VGA Port	1
	RJ-45	4 x GbE LAN 1 x Management LAN
Management Solution	PS/2 KB/Mouse	1
	Software	ASWM Enterprise
	Out of Band Remote Management	Optional ASMB7-iKVM for KVM-over-Internet
Monitoring	CPU Temperature	✓
	FAN RPM	✓
Environment		Operating temperature: 10°C – 35°C (50°F – 95°F) Non operating temperature: -40°C – 70°C (-40°F – 158°F) Non operating humidity: 20% – 90% (Non condensing)



Specifications are subject to change without notice.

Chapter 1: Product Introduction

1

Chapter summary

This chapter describes the motherboard features and the new technologies it supports. This chapter contains the following sections:

1.1	Welcome!	1-3
1.2	Package contents.....	1-3
1.3	Serial number label.....	1-4
1.4	Special features.....	1-4

1.1 Welcome!

Thank you for buying an ASUS® P9D-E/4L motherboard!

The motherboard delivers a host of new features and latest technologies, making it another standout in the long line of ASUS quality motherboards!

Before you start installing the motherboard and hardware devices on it, check the items in your package with the list below.

1.2 Package contents

Check your motherboard package for the following items.

Items		Standard Gift Box Pack	Standard Bulk Pack
I/O Shield		1	1
Cables	SATA DOM Power cable	1	--
	SATA 3G cable	2	--
	SATA 6G cable	4	--
	COM port cable	1	--
Application CD	Support CD	1	1
	ASWM Enterprise SDVD	1	1
Documentation	Motherboard User Guide	1	1
Accessory	Metal Plate for LGA1150	1	1
Packaging Qty.		1 pc per carton	10 pcs per carton



If any of the above items is damaged or missing, contact your retailer.

Optional items	Description
PIKE 2008	LSI 8-port SAS 6G RAID card
PIKE 2008/IMR	LSI 8-port SAS 6G RAID card
PIKE 2108	LSI 8-port SAS 6G HW RAID card
PIKE 2208	LSI 8-port SAS 6G HW RAID card
PIKE 2308	LSI 8-port SAS 6G RAID card
PIKE 9230	MARVELL 4-port SATA 6G RAID card
ASMB7-iKVM	Remote Management solution provides KVM over IP solution
MIO-892	Discrete 8-channel audio card provides clearest high quality sounds

1.3 Serial number label

Before requesting support from the ASUS Technical Support team, you must take note of the motherboard's serial number containing 12 characters **xxS2xxxxxxxx** shown as the figure below. With the correct serial number of the product, ASUS Technical Support team members can then offer a quicker and satisfying solution to your problems.



1.4 Special features

1.4.1 Product highlights

Latest processor technology

This motherboard supports the latest Intel® Xeon® Processor E3-1200 v3/ Core™ i3 series in LGA1150 package, which has memory and PCI Express controller integrated to support 2-channel (4 DIMMs) DDR3 memory and 16 PCI Express 3.0 lanes. The Intel® Xeon® E3-1200 v3 have improve CPU performance and integrated voltage regulators making it one of the most powerful and energy efficient CPU in the world.

Intel® Turbo Boost

Intel® Turbo Boost automatically allows the processor to run faster than the marked frequency if the processor is operating below its power, current, and temperature specification limits. This technology increases performance of both multi-threaded and single-threaded workloads.

Intel® Hyper Threading

The thread-level parallelism on each processor makes more efficient use of the processor resources, higher processing throughput and improved performance on today's multi-threaded software.

Intel® EM64T

The motherboard supports Intel® processors with the Intel® EM64T (Extended Memory 64 Technology). The Intel® EM64T feature allows your computer to run on 64-bit operating systems and access larger amounts of system memory for faster and more efficient computing.

DDR3 memory support

The motherboard supports ECC UDIMM DDR3 memory that features data transfer rates of 1600/1333 MHz to meet the higher bandwidth requirements of server and workstation applications. The dual-channel DDR3 architecture boosts system performance, eliminates bottlenecks with peak bandwidth up to 25Gb/s, and dramatically reduces the memory voltage to just 1.5V compared to DDR2's memory voltage of 1.8V.

PCI Express 3.0

PCI Express[®] 3.0 (PCIe 3.0) is the PCI Express bus standard that provides twice the performance and speed of PCIe 2.0. It provides an optimal graphics performance, unprecedented data speed, and seamless transition with its complete backward compatibility to PCIe 1.0/2.0 devices.

Intel[®] I210AT LAN Solution

The motherboard comes with four Gigabit LAN controllers and ports which provide a total solution for your networking needs. The onboard Intel[®] I210AT Gigabit LAN controllers use the PCI Express interface and could achieve network throughput close to Gigabit bandwidth.

Enhanced Intel SpeedStep Technology (EIST)

The Enhanced Intel SpeedStep Technology (EIST) intelligently manages the CPU resources by automatically adjusting the CPU voltage and core frequency depending on the CPU loading and system speed or power requirement.

Serial ATA II technology

The motherboard supports the Serial ATA II 3 Gb/s technology through the Serial ATA interface and Intel[®] C224 chipset. The Serial ATA II specification provides twice the bandwidth of the current Serial ATA products with a host of new features, including Native Command Queuing (NCQ), Power Management (PM) Implementation Algorithm, and Hot Swap. Serial ATA allows thinner, more flexible cables with lower pin count and reduced voltage requirements.

Serial ATA III technology

The motherboard supports the Serial ATA III 6 Gb/s technology through the Serial ATA interface and Intel[®] C224 chipset. Get enhanced scalability, faster data retrieval, double the bandwidth of current bus systems with up to 6Gbps data transfer rates.

USB 2.0 technology

The motherboard implements the Universal Serial Bus (USB) 2.0 specification that dramatically increases the connection speed from the 12 Mbps bandwidth on USB 1.1 to a fast 480 Mbps on USB 2.0. USB 2.0 is backward compatible with USB 1.1.

USB 3.0 technology

The motherboard implements the USB 3.0 technology with data transfer speeds of up to 5Gbps, faster charging time for USB-chargeable devices, optimized power efficiency, and backward compatibility with USB 2.0.

Temperature, fan, and voltage monitoring

The CPU temperature is monitored to prevent overheating and damage. The system fan rotations per minute (RPM) is monitored for timely failure detection. The chip monitors the voltage levels to ensure stable supply of current for critical components.

1.4.2 Innovative ASUS features

ASUS Fan Speed technology

The ASUS Fan Speed technology smartly adjusts the fan speeds according to the system loading to ensure quiet, cool, and efficient operation.

PIKE (Proprietary I/O Kit Expansion)

PIKE is an on-demand upgrade kit for users. This ASUS unique feature enables users to choose their preferred I/O solutions. ASUS provides multiple SAS solutions for different segments and purposes and PIKE saves lots of validation efforts and hardware cost for end users. Moreover, the special patent design offers multiple I/O solutions without occupying the Slot 6 in a 1U system.

ASUS MIO Audio card

The ASUS MIO audio card is a discrete 8-channel high definition audio (High Definition Audio previously codenamed Azalia) CODEC that enables the clearest high quality audio output. It has jack-sensing feature, retasking functions, and multi-streaming technology that simultaneously send different audio streams to different destinations for high-end sound quality.

Chapter 2: Hardware Information

Chapter summary

This chapter lists the hardware setup procedures that you have to perform when installing system components. It includes description of the jumpers and connectors on the motherboard. This chapter contains the following sections:

2.1	Before you proceed	2-3
2.2	Motherboard overview.....	2-4
2.3	Central Processing Unit (CPU)	2-8
2.4	System memory	2-14
2.5	Expansion slots.....	2-16
2.6	Onboard LEDs.....	2-23
2.7	Jumpers	2-26
2.8	Connectors	2-29

2.1 Before you proceed

Take note of the following precautions before you install motherboard components or change any motherboard settings.



-
- Unplug the power cord from the wall socket before touching any component.
 - Use a grounded wrist strap or touch a safely grounded object or a metal object, such as the power supply case, before handling components to avoid damaging them due to static electricity.
 - Hold components by the edges to avoid touching the ICs on them.
 - Whenever you uninstall any component, place it on a grounded antistatic pad or in the bag that came with the component.
 - Before you install or remove any component, ensure that the power supply is switched off or the power cord is detached from the power supply. Failure to do so may cause severe damage to the motherboard, peripherals, and/or components.
-

2.2 Motherboard overview

Before you install the motherboard, study the configuration of your chassis to ensure that the motherboard fits into it.

To optimize the motherboard features, we highly recommend that you install it in an ATX 1.1 compliant chassis.



Ensure to unplug the chassis power cord before installing or removing the motherboard. Failure to do so can cause you physical injury and damage motherboard components!

2.2.1 Placement direction

When installing the motherboard, ensure that you place it into the chassis in the correct orientation. The edge with external ports goes to the rear part of the chassis as indicated in the image below.

2.2.2 Screw holes

Place nine (9) screws into the holes indicated by circles to secure the motherboard to the chassis.



DO NOT overtighten the screws! Doing so can damage the motherboard.

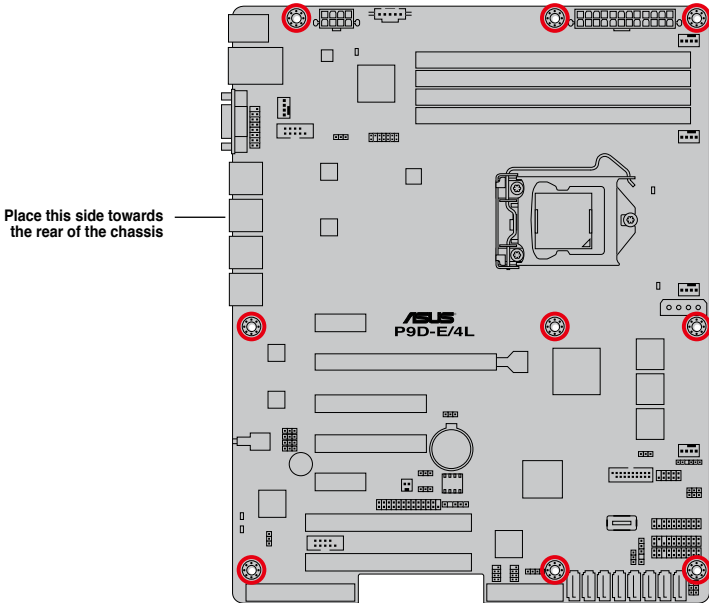

2.2.3 Motherboard layout

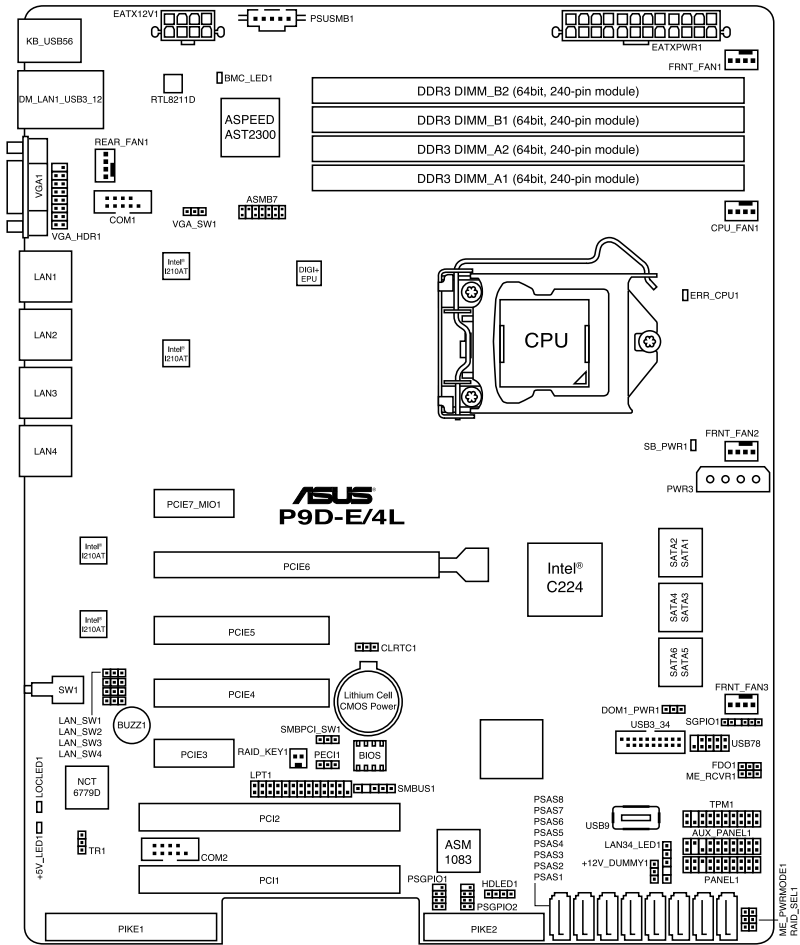

2.2.4 Layout contents

Slots/Sockets		Page
1.	CPU sockets	2-8
2.	DDR3 sockets	2-14
3.	PCI Express x16 / PCI Express x8 / PCI Express x1 / PCI slot	2-17
4.	PIKE slot	2-18

Onboard LEDs		Page
1.	Standby Power LED (SB_PWR1)	2-22
2.	Baseboard Management Controller LED (BMC_LED1)	2-22
3.	CPU Warning LED (ERR_CPU1)	2-23
4.	Power LED (+5V_LED)	2-23
5.	Location LED (LOCLED1)	2-24

Jumpers		Page
1.	Clear RTC RAM (CLRTC1)	2-25
2.	VGA controller setting (3-pin VGA_SW1)	2-26
3.	LAN controller setting (3-pin LAN_SW1, LAN_SW2, LAN_SW3, LAN_SW4)	2-26
4.	RAID configuration utility selection (3-pin RAID_SEL1)	2-27
5.	Platform Environmental Control Interface (PECI) Setting (3-pin PECI1)	2-27

Rear panel connectors		Page
1.	PS/2 keyboard/mouse port (purple/green)	2-28
2.	RJ-45 port for iKVM	2-28
3.	Video Graphics Adapter port	2-28
4.	RJ-45 ports for LAN.	2-28
5.	Power-on Button	2-28
6.	Location LED	2-28
7.	Power LED	2-28
8.	USB 2.0 ports 1 and 2	2-28
9.	USB 3.0 ports 1 and 2	2-28

Internal connectors		Page
1.	Serial ATA 6.0/3.0 Gbps connector (7-pin 6Gbps SATA1, SATA2, SATA3, SATA4 [Light Blue]) (7-pin 3Gbps SATA5, SATA6 [Black])	2-29
2.	PSAS connectors (7-pin PSAS1, PSAS2, PSAS3, PSAS4, PSAS5, PSAS6, PSAS7, PSAS8 [Light Blue])	2-30
3.	Hard disk activity LED connector (4-pin HDLED1)	2-30
4.	USB 2.0 connector (10-1 pin USB78; A-Type USB9)	2-31
5.	USB 3.0 connector (20-1 pin USB3_34)	2-31
6.	Thermal sensor cable connectors (3-pin TR1)	2-32
7.	CPU, front, and rear fan connectors (4-pin CPU_FAN1, FRNT_FAN1, FRNT_FAN2, FRNT_FAN3, REAR_FAN1)	2-32
8.	Serial General Purpose Input/Output connector (6-1 pin SGPIO1)	2-33
	PIKE Serial General Purpose Input/Output connectors (8-1 pin PSGPIO1, PSGPIO2)	2-33
9.	Serial port connectors (10-1 pin COM1/COM2)	2-34
10.	Power Supply SMBus connector (5-pin PSUSMB1)	2-34
11.	Trusted Platform Module connector (20-1 pin TPM1)	2-35
12.	SATA DOM power connector (4-pin PWR3)	2-35
13.	LAN34_LED connector (5-pin LAN34_LED1)	2-36
14.	Parallel port connector (26-1 pin LPT1)	2-36
15.	VGA connector (16-pin VGA_HDR1)	2-37
16.	ATX power connectors (24-pin EATXPWR1, 8-pin EATX12V1)	2-38
17.	System panel connector (20-1 pin PANEL1)	2-39
18.	Auxiliary panel connector (20-2 pin AUX_PANEL1)	2-40

2.3 Central Processing Unit (CPU)

The motherboard comes with a surface mount LGA1150 socket designed for the Intel® Xeon® E3-1200 v3 and Intel® Core™ i3 processor.



- Upon purchase of the motherboard, ensure that the PnP cap is on the socket and the socket contacts are not bent. Contact your retailer immediately if the PnP cap is missing, or if you see any damage to the PnP cap/socket contacts/motherboard components. ASUS will shoulder the cost of repair only if the damage is shipment/transit-related.
- Keep the cap after installing the motherboard. ASUS will process Return Merchandise Authorization (RMA) requests only if the motherboard comes with the cap on the LGA1150 socket.
- The product warranty does not cover damage to the socket contacts resulting from incorrect CPU installation/removal, or misplacement/loss/incorrect removal of the PnP cap.

2.3.1 Installing the CPU

To install the CPU:

1. Locate the CPU socket on the motherboard.

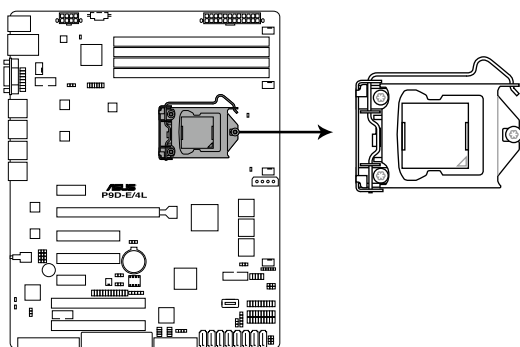

P9D-E/4L CPU LGA1150



Before installing the CPU, ensure that the socket box is facing toward you and the load lever is on your right.

2. Press the load lever with your thumb (A), then move it to the right (B) until it is released from the retention tab.



Do not remove the PnP cap yet from the CPU socket. Doing so may bend the pins of the socket.

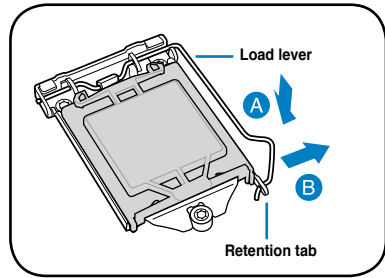

3. Lift the load lever until the load plate is completely lifted.

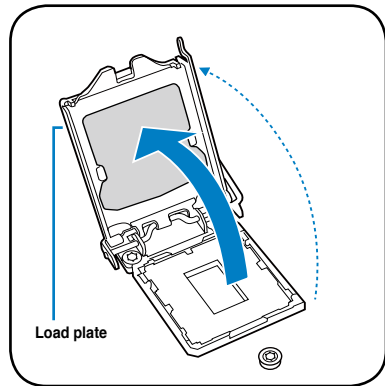

4. Position the CPU above the socket, ensuring that the gold triangle mark is on the bottom-left corner of the socket, then fit the CPU notches to the socket's alignment keys.



The CPU fits in only one orientation. DO NOT force the CPU into the socket to prevent bending the pins on the socket and damaging the CPU.

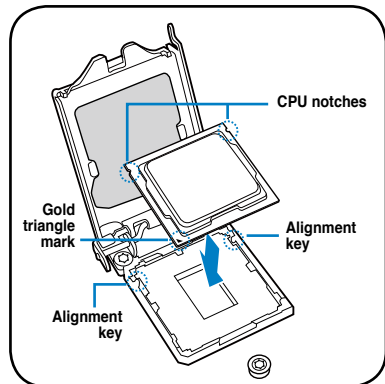

5. Close the load plate (A), ensuring that the front edge of the load plate slides under the retention lock (B) then push down the load lever (C).

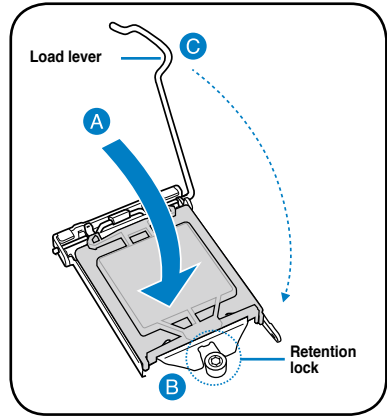

6. Insert the load lever under the retention tab to remove the PnP cap from the CPU socket.

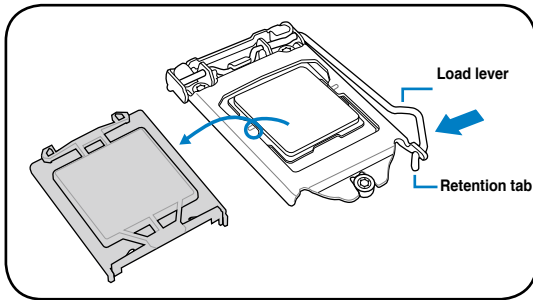

7. Apply some Thermal Interface Material to the exposed area of the CPU that the heatsink will be in contact with, ensuring that it is evenly spread in a thin layer.



Some heatsinks come with pre-applied Thermal Interface Material. If so, skip this step.



The Thermal Interface Material is toxic and inedible. DO NOT eat it. If it gets into your eyes or touches your skin, wash it off immediately and seek professional medical help.

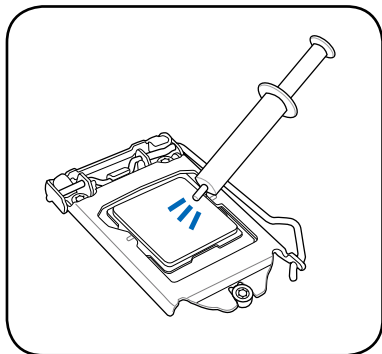

2.3.2 Installing the CPU heatsink

The Intel® LGA1150 processor requires a specially designed CPU heatsink to ensure optimum thermal condition and performance.



- If you buy a CPU separately, ensure that you use only Intel® certified multi-directional CPU heatsink or CPU heatsink with CPU fan.
- Use an LGA1150-compatible CPU heatsink and CPU fan assembly only. The LGA1150 socket is incompatible with the LGA775 and LGA1366 sockets in size and dimension.



If you purchased a separate CPU heatsink and fan assembly, ensure that the Thermal Interface Material is properly applied to the CPU heatsink or CPU before you install the heatsink and fan assembly.



Ensure that you have installed the motherboard to the chassis before you install the CPU fan and heatsink assembly.

To install the CPU heatsink and fan:

1. Place the heatsink on top of the installed CPU, making sure that the four fasteners match the holes on the motherboard.
2. Push down two fasteners at a time in a diagonal sequence to secure the heatsink and fan assembly in place.

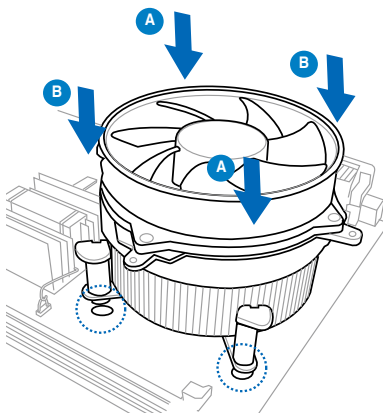
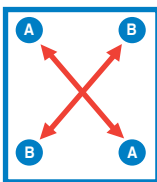

Orient the heatsink and fan assembly such that the CPU fan cable is closest to the CPU fan connector.

3. Connect the CPU fan cable to the connector on the motherboard labeled CPU_FAN1.

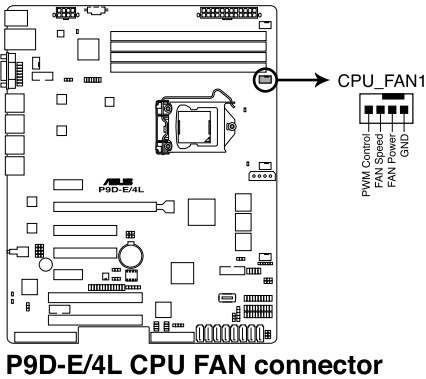

DO NOT forget to connect the CPU fan connector! Hardware monitoring errors can occur if you fail to plug this connector.

2.3.3 Uninstalling the CPU heatsink and fan

To uninstall the CPU fan and fan:

1. Disconnect the CPU fan cable from the connector on the motherboard.
2. Rotate each fastener counterclockwise.
3. Pull up two fasteners at a time in a diagonal sequence to disengage the heatsink and fan assembly from the motherboard.

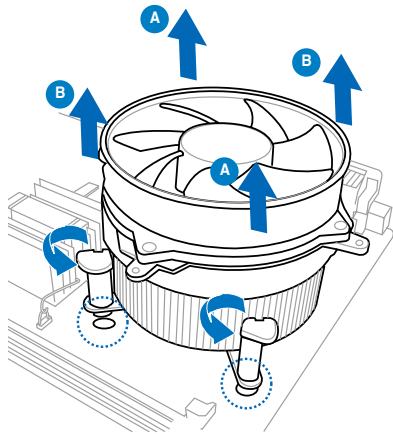
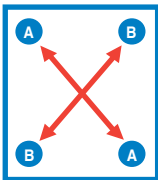

4. Carefully remove the heatsink and fan assembly from the motherboard.

2.3.4 Installing the CPU heatsink in rack

The Intel® 1150 processor requires a specially designed heatsink to ensure optimum thermal condition and performance.



- Ensure that you use qualified heatsink assembly only.
- Ensure that you have applied the thermal interface material to the top of the CPU before installing the heatsink and fan.

1. Peel off the sticker on the heatsink metal plate and affix the plate to the back of the motherboard, matching the standoffs to the heatsink screw holes.

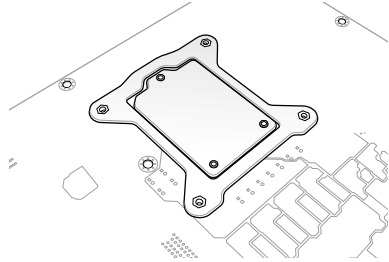

2. Use a Phillips screwdriver to tighten the four heatsink screws using the recommended sequence below.

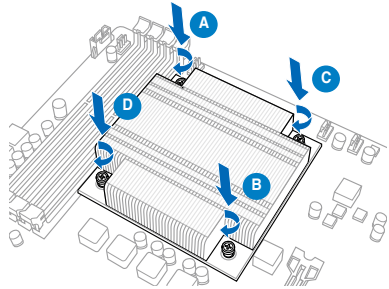
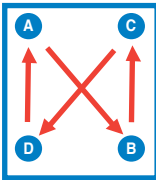

- Ensure that the heatsink is not skewed or tilted, otherwise the CPU will overheat.
- Do not overtighten the screws. Doing so can damage the CPU.

2.4 System memory

2.4.1 Overview

The motherboard comes with four Double Data Rate 3 (DDR3) Dual Inline Memory Modules (DIMM) sockets.

A DDR3 module has the same physical dimensions as a DDR2 DIMM but is notched differently to prevent installation on a DDR2 DIMM socket. DDR3 modules are developed for better performance with less power consumption.

The figure illustrates the location of the DDR3 DIMM sockets:

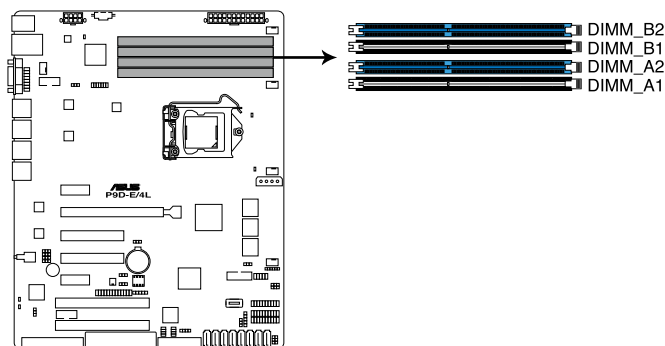

P9D-E/4L 240-pin DDR3 DIMM sockets

2.4.2 Memory Configurations

You may install 2 GB, 4 GB, and 8 GB Unbuffered with ECC DDR3 DIMMs into the DIMM sockets using the memory configurations in this section.

UDIMM				
DIMM Slot Per Channel	DIMM Populated per Channel	DIMM Type	Speed	Rank per DIMM
2	1	Unbuffered DDR3	1333/1600	Single Rank, Dual Rank
2	2	Unbuffered DDR3	1333/1600	Single Rank, Dual Rank



- Always install DIMMs with the same CAS latency. For optimum compatibility, it is recommended that you obtain memory modules from the same vendor.
- Start installing the DIMMs in slots A2 and B2 (Blue).

2.4.3 Installing a DIMM on a single clip DIMM socket

1. Unlock a DIMM socket by pressing the retaining clip outward.
2. Align a DIMM on the socket such that the notch on the DIMM matches the DIMM slot key on the socket.

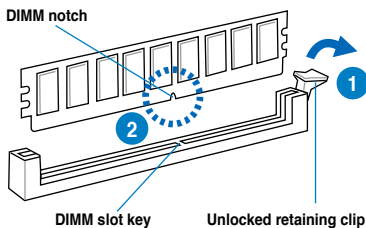

A DIMM is keyed with a notch so that it fits in only one direction. DO NOT force a DIMM into a socket in the wrong direction to avoid damaging the DIMM.

3. Hold the DIMM by both of its ends then insert the DIMM vertically into the socket. Apply force to both ends of the DIMM simultaneously until the retaining clip snaps back into place and the DIMM cannot be pushed in any further to ensure proper sitting of the DIMM.

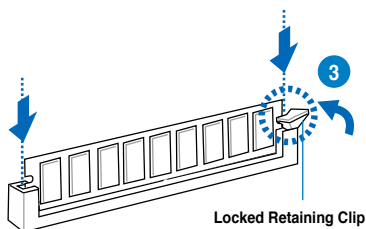

Always insert the DIMM into the socket vertically to prevent DIMM notch damage.



- To install two or more DIMMs, refer to the user guide bundled in the motherboard package.
- Refer to the user guide for qualified vendor lists of the memory modules.

Removing a DIMM from a single clip DIMM socket

1. Press the retaining clip outward to unlock the DIMM.
2. Remove the DIMM from the socket.

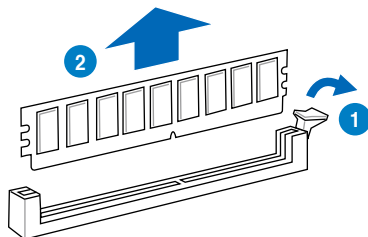

Support the DIMM lightly with your fingers when pressing the retaining clips. The DIMM might get damaged when it flips out with extra force.

2.5 Expansion slots

In the future, you may need to install expansion cards. The following subsections describe the slots and the expansion cards that they support.



Ensure to unplug the power cord before adding or removing expansion cards. Failure to do so may cause you physical injury and damage motherboard components.

2.5.1 Installing an expansion card

To install an expansion card:

1. Before installing the expansion card, read the documentation that came with it and make the necessary hardware settings for the card.
2. Remove the system unit cover (if your motherboard is already installed in a chassis).
3. Remove the bracket opposite the slot that you intend to use. Keep the screw for later use.
4. Align the card connector with the slot and press firmly until the card is completely seated on the slot.
5. Secure the card to the chassis with the screw you removed earlier.
6. Replace the system cover.

2.5.2 Configuring an expansion card

After installing the expansion card, configure it by adjusting the software settings.

1. Turn on the system and change the necessary BIOS settings, if any. See Chapter 4 for information on BIOS setup.
2. Assign an IRQ to the card. Refer to the tables on the next page.
3. Install the software drivers for the expansion card.



When using PCI cards on shared slots, ensure that the drivers support "Share IRQ" or that the cards do not need IRQ assignments. Otherwise, conflicts will arise between the two PCI groups, making the system unstable and the card inoperable.

2.5.3 Interrupt assignments

Standard Interrupt assignments

IRQ	Priority	Standard function
0	1	System Timer
1	2	Keyboard Controller
2	-	Programmable Interrupt
3*	11	Communications Port (COM2)
4*	12	Communications Port (COM1)
5*	13	--
6	14	Floppy Disk Controller
7*	15	--
8	3	System CMOS/Real Time Clock
9*	4	ACPI Mode when used
10*	5	IRQ Holder for PCI Steering
11*	6	IRQ Holder for PCI Steering
12*	7	PS/2 Compatible Mouse Port
13	8	Numeric Data Processor
14*	9	Primary IDE Channel
15*	10	Secondary IDE Channel

* These IRQs are usually available for ISA or PCI devices.

2.5.4 PCI Express x16 slot (x16 link)

The onboard PCIE6 slot provides one x16 Gen3 link and auto switches to x8 link if PCIE5 is occupied. This slot supports VGA cards and various server class high performance add-on cards.

2.5.5 PCI Express x8 slot (x8 link)

The onboard PCIE 4 and PCIE 5 provide one x8 Gen3 link. These slots support VGA cards and various server class high performance add-on cards.

2.5.6 PCI Express x1 slot (x1 link)

The onboard PCIE 3 and PCIE 7 provide one x1 Gen2 link to the Intel® C224 PCH.

2.5.7 PCI slot

The PCI 1 and PCI 2 slots supports cards such as LAN, USB, and other cards that complies with PCI specifications.

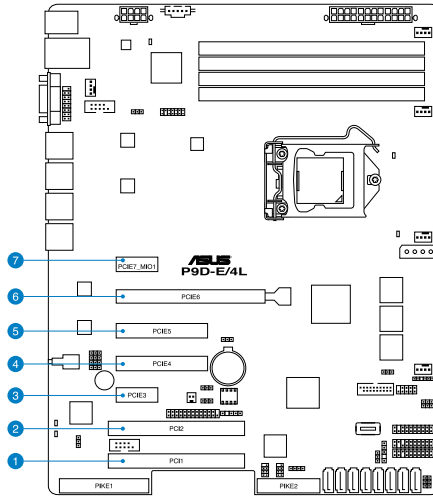

No.(Slot location)	Short Description	
1 (slot 1)	PCI1	PCI 32 bit/ 33 MHz
2 (slot 2)	PCI2	PCI 32 bit/ 33 MHz
3 (slot 3)	PCIE3	PCI-E x1 (x1 Gen2 link)
4 (slot 4)	PCIE4	PCI-E x8 (x8 Gen3 link)
5 (slot 5)	PCIE5	PCI-E x8 (x8 Gen3 link)
6 (slot 6)	PCIE6	PCI-E x16 (x16 Gen3 link) (Auto switch to x8 if slot 5 is occupied)
7 (slot 7)	PCIE7	PCI-E x1 (x1 Gen2 link); MIO-892 Supported

2.5.8 PIKE slot

The PIKE slots allows you to choose and change your preferred SAS solution easily. Install an optional ASUS PIKE RAID card based on your needs.

2.5.9 Installing the ASUS PIKE RAID card

Follow the steps below to install an optional ASUS RAID card on your motherboard.

1. Locate the PIKE RAID card slot on the motherboard.

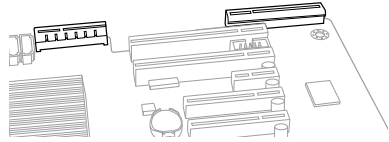

2. Align the golden fingers of the RAID card with the PIKE RAID card slot.

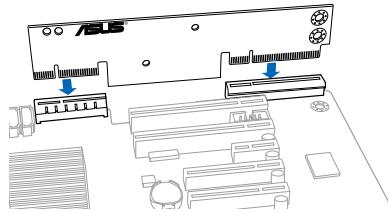

3. Insert the RAID card into the PIKE RAID card slot. Ensure that it is completely seated on the PIKE RAID card slot.

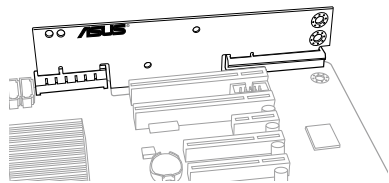

- The motherboard illustration is for reference only. The motherboard layout and appearance may vary depending on the model, but the installation steps remain the same.
- Refer to section **2.8.2 Internal Connectors** for the PIKE SAS/SATA connector location.

2.5.10 Installing the Baseboard Management Card

Follow the steps below to install an optional ASMB7 Management Card on your motherboard.

1. Locate the Baseboard Management Card header on the motherboard.

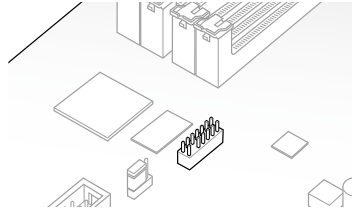

2. Orient and press the Management Card in place.

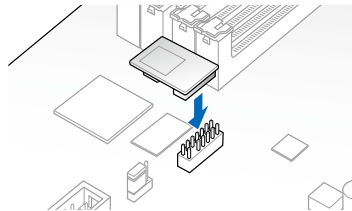

The motherboard illustration is for reference only. The motherboard layout and appearance may vary depending on the model, but the installation steps remain the same.

2.5.11 Connecting the Thermal sensor cable

Follow the steps below to connect the Thermal sensor (TR1) cable to the connector on your motherboard.

1. Locate the Thermal Sensor (TR1) connector on the motherboard.

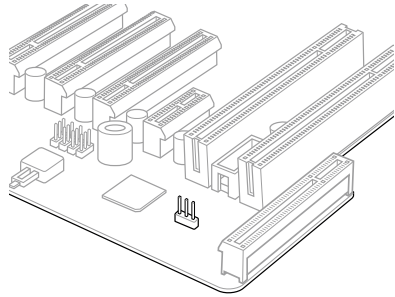

2. Connect the Thermal Sensor cable to the connector.

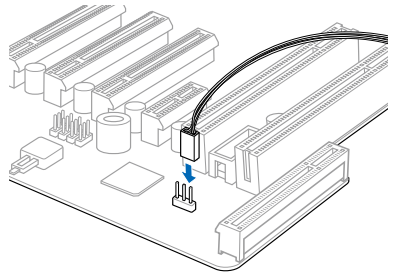

3. Place the other end of the Thermal Sensor cable to the device you would like to monitor temperature.



The motherboard illustration is for reference only. The motherboard layout and appearance may vary depending on the model, but the installation steps remain the same.

2.5.12 Installing the Audio card

1. Locate the MIO card slot on the motherboard and align the golden fingers of the audio card with the MIO card slot.
2. Insert the audio card into the MIO slot on the motherboard. Ensure that it is completely seated on the card slot.
3. Secure the audio card to the chassis with a screw.

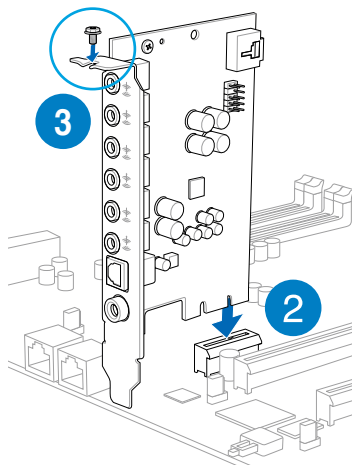

2.6 Onboard LEDs

1. Standby Power LED (SB_PWR1)

The motherboard comes with a standby power LED. The green LED lights up to indicate that the system is ON, in sleep mode, or in soft-off mode. This is a reminder that you should shut down the system and unplug the power cable before removing or plugging in any motherboard component. The illustration below shows the location of the onboard LED.

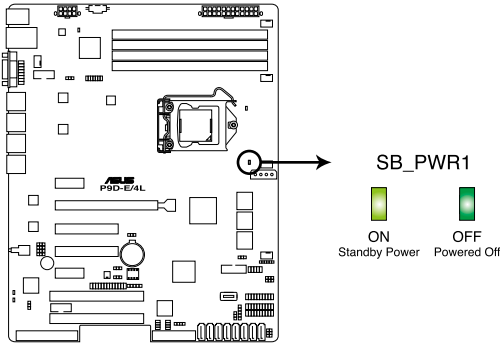

P9D-E/4L Standby Power LED

2. Baseboard Management Controller LED (BMC_LED1)

The green heartbeat LED blinks per second to indicate that the ASMB7 is working normally. The BMC LED works with the ASUS ASMB7 management device and indicates its initiation status. When the PSU is plugged and the system is OFF, ASUS ASMB7 management device starts system initiation for about one (1) minute. The BMC LED blinks after system initiation finishes.

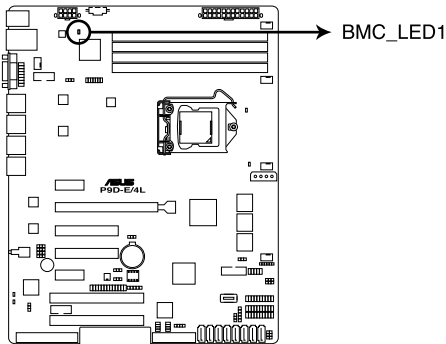

P9D-E/4L BMC LED



- The heartbeat LED functions only when you install the ASUS ASMB7 Management card.
- Everytime after the AC power is replugged, you have to wait for about 60 seconds for the system to power up.

3. CPU Warning LED (ERR_CPU1)

The CPU warning LED lights up to indicate that a CPU error or failure has occurred.

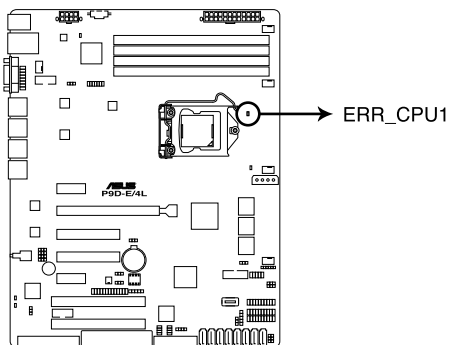

P9D-E/4L ERR CPU LED



The warning LED functions only when you install the ASUS ASMB7 Management card.

4. Power LED (+5V_LED1)

This LED lights up when the Power-on button is pressed and the system is on.

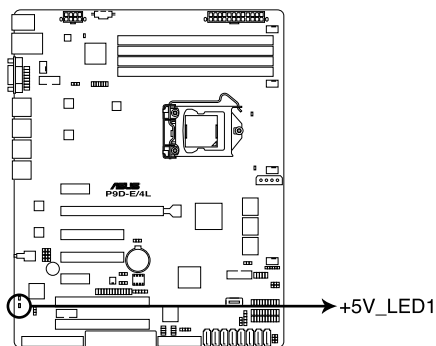

P9D-E/4L +5V Power LED

5. Location LED (LOCLED1)

The Location LED is an onboard LED that lights up when the Location Button on the front panel is pressed. This LED helps you visually locate the server among other servers especially when you are located at the back of the server rack.

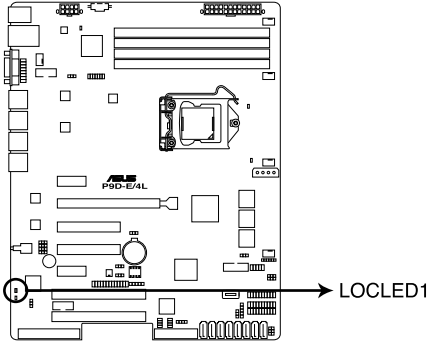

P9D-E/4L Location LED

2.7 Jumpers

1. Clear RTC RAM (3-pin CLRTC1)

This jumper allows you to clear the Real Time Clock (RTC) RAM in CMOS. You can clear the CMOS memory of date, time, and system setup parameters by erasing the CMOS RTC RAM data. The onboard button cell battery powers the RAM data in CMOS, which include system setup information such as system passwords.

To erase the RTC RAM:

1. Turn OFF the computer and unplug the power cord.
2. Move the jumper cap from pins 1–2 (default) to pins 2–3. Keep the cap on pins 2–3 for about 5–10 seconds, then move the cap back to pins 1–2.
3. Plug the power cord and turn ON the computer.
4. Hold down the key during the boot process and enter BIOS setup to re-enter data.



Except when clearing the RTC RAM, never remove the cap on CLRTC jumper default position. Removing the cap will cause system boot failure!



If the steps above do not help, remove the onboard battery and move the jumper again to clear the CMOS RTC RAM data. After the CMOS clearance, reinstall the battery.

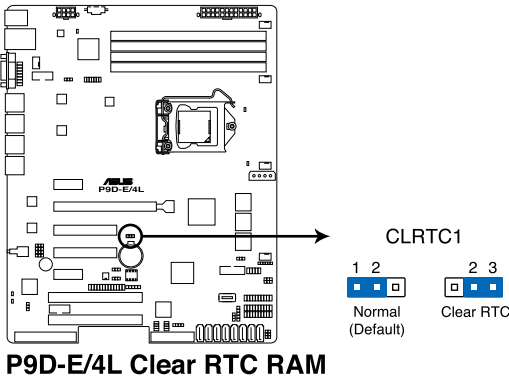

2. VGA controller setting (3-pin VGA_SW1)

This jumper allows you to enable or disable the onboard VGA controller. Set to pins 1–2 to activate the VGA feature.

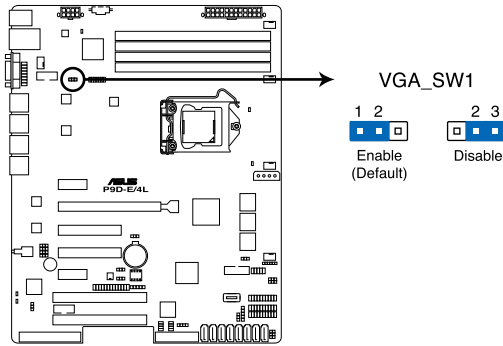

P9D-E/4L VGA setting

3. LAN controller setting (3-pin LAN_SW1, LAN_SW2, LAN_SW3, LAN_SW4)

These jumpers allow you to enable or disable the onboard Intel® I210AT Gigabit LAN controllers. Set to pins 1-2 to activate the Gigabit LAN feature.

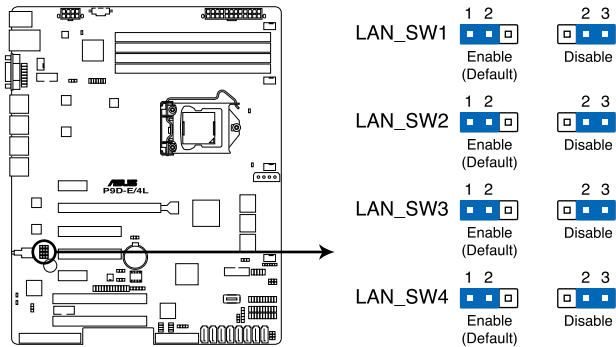

P9D-E/4L LAN setting

4. RAID configuration utility selection (3-pin RAID_SEL1)

This jumper allows you to select the RAID configuration utility to use when you create disk arrays. Place the jumper caps over pins 1–2 if you want to use the third party software RAID Utility; otherwise, place the jumper caps to pins 2–3 to use the Intel® Rapid Storage Technology enterprise SATA Option ROM Utility.

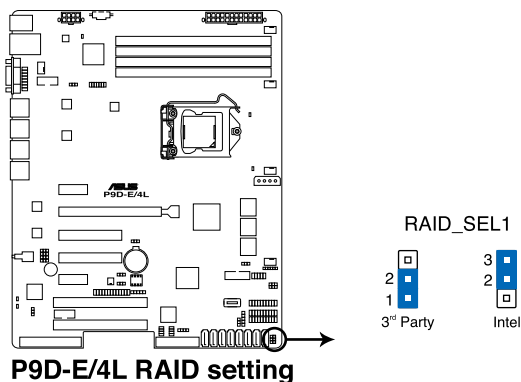

5. Platform Environmental Control Interface Setting (3-pin PECI1)

When an ASMB7-iKVM is installed, set these to pins 2-3 for correct sensor information of the Platform Environmental Control Interface (PECI). Set to pins 1-2 if ASMB7-iKVM is not installed.

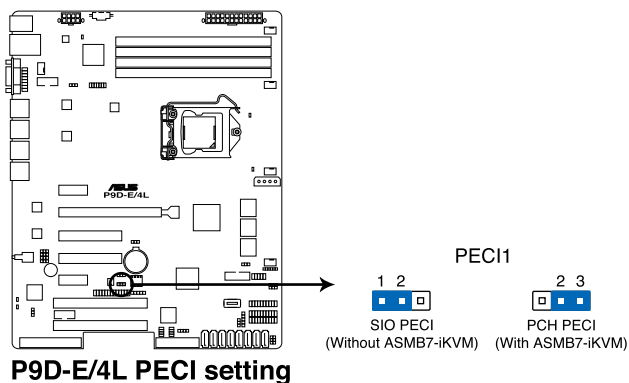

2.8 Connectors

2.8.1 Rear panel connectors

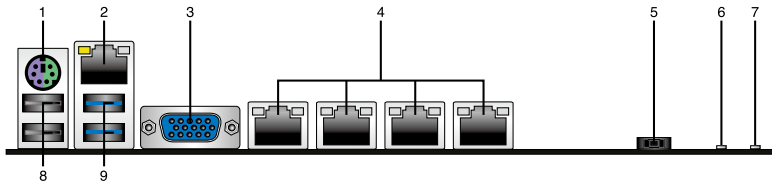

1. **PS/2 keyboard/mouse port (purple/green).** This port is for a PS/2 keyboard or mouse.
2. **RJ-45 port for iKVM.** This RJ-45 port functions only when you install ASMB7 management card.
3. **Video Graphics Adapter port.** This port is for a VGA monitor or other VGA-compatible devices.
4. **RJ-45 ports for LAN.** These ports allows Gigabit connection to a Local Area Network (LAN) through a network hub. Refer to the table below for the LAN port LED indications.
5. **Power-on Button.** Press this button to turn on the system.
6. **Location LED.** The Location LED is an onboard LED that ligths up when the Location Button on the front panel is pressed. This LED helps you visually locate the server among other servers especially when you are located at the back of the server rack.
7. **Power LED.** This LED lights up when the Power-on button is pressed and the system is on.
8. **USB 2.0 ports 1 and 2.** These two 4-pin Universal Serial Bus (USB) ports are available for connecting USB 2.0 devices.
9. **USB 3.0 ports 1 and 2.** These two 4-pin USB ports are available for connecting USB 3.0 devices.

LAN port LED indications

Activity/Link LED		Speed LED	
Status	Description	Status	Description
OFF	No link	OFF	10 Mbps connection
GREEN	Linked	ORANGE	100 Mbps connection
BLINKING	Data activity	GREEN	1 Gbps connection

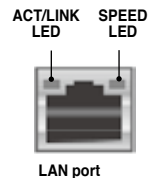

2.8.2 Internal connectors

1. Serial ATA 6.0/3.0 Gbps connectors

(7-pin 6Gbps SATA1, SATA2, SATA3, SATA4 [Light Blue])

(7-pin 3Gbps SATA5, SATA6 [Black])

Supported by the Intel® C224 chipset, these connectors are for the Serial ATA signal cables for Serial ATA hard disk drives that allows up to 6Gbps of data transfer rate. If you installed Serial ATA hard disk drives, you can create a RAID 0, RAID 1, RAID 10, or RAID 5 configuration.

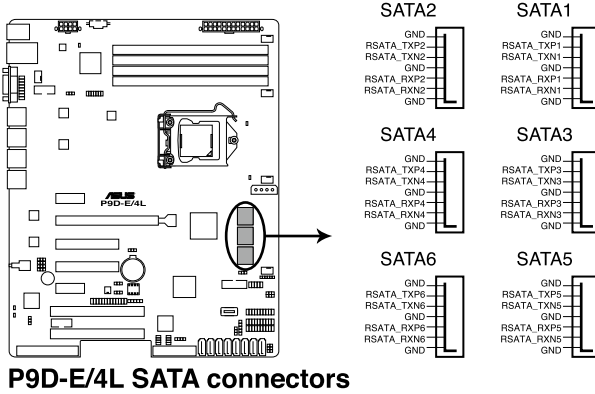

The actual data transfer rate depends on the speed of Serial ATA hard disks installed.

2. PSAS connectors

(7-pin PSAS1, PSAS2, PSAS3, PSAS4, PSAS5, PSAS6, PSAS7, PSAS8 [Light Blue])

This motherboard comes with eight (8) PIKE Serial Attached SCSI (PSAS) connectors that supports both Serial Attached SCSI (SAS) and Serial ATA (SATA). Each connector supports one device.



- These connectors function only when you install a PIKE RAID card.
- Connect the SAS hard disk drives to PSAS connectors 1–8 (blue) when installing a PIKE RAID card.

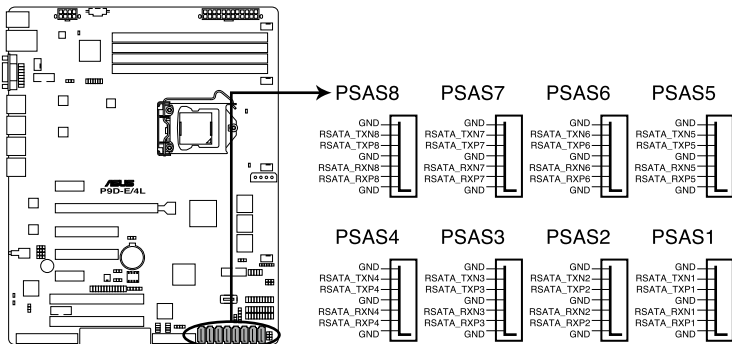

P9D-E/4L PSAS connectors

3. Hard disk activity LED connector (4-pin HDLED1)

This LED connector is for the storage add-on card cable connected to the SATA or SAS add-on card. The read or write activities of any device connected to the SATA or SAS add-on card causes the front panel LED to light up.

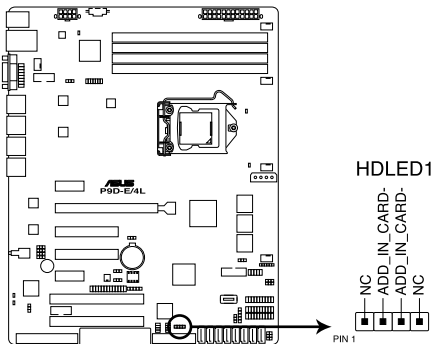

P9D-E/4L Storage card activity LED connector

4. USB 2.0 connector (10-1 pin USB78; A-Type USB9)

These connectors are for USB 2.0 ports. Connect the USB module cables to these connectors. These USB connectors comply with USB 2.0 specification that supports up to 480 Mbps connection speed.

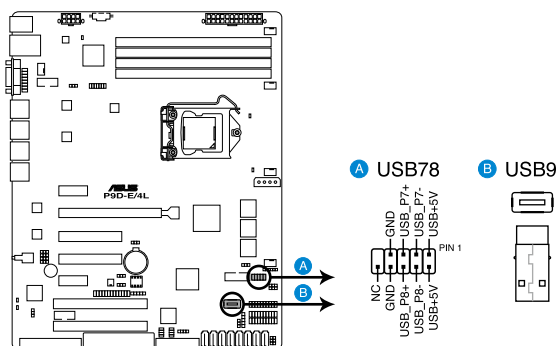

P9D-E/4L USB 2.0 connectors

5. USB 3.0 connector (20-1 pin USB3_34)

These connectors allow you to connect a USB 3.0 module for additional USB 3.0 front or rear panel ports. With an installed USB 3.0 module, you can enjoy all the benefits of USB 3.0 including faster data transfer speeds of up to 5Gbps, faster charging time for USB-chargeable devices, optimized power efficiency, and backward compatibility with USB 2.0.

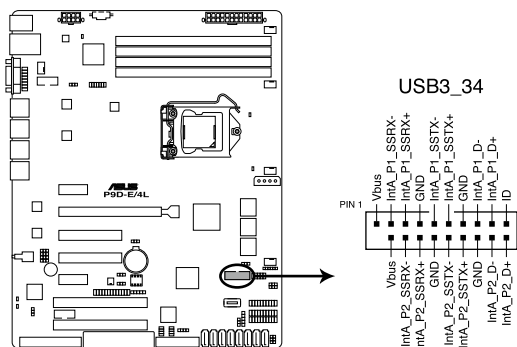

P9D-E/4L USB 3.0 connector

6. Thermal sensor cable connectors (3-pin TR1)

This connector allows you to connect a Thermal sensor cable that is used for monitoring temperature. Connect the Thermal sensor cable to the connector and place its probe to the device that you want to monitor.

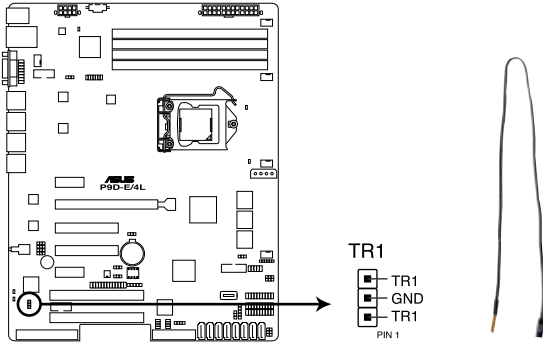

P9D-E/4L Thermal sensor cable connector

7. CPU, front, and rear fan connectors

(4-pin CPU_FAN1, FRNT_FAN1, FRNT_FAN2, FRNT_FAN3, REAR_FAN1)

The fan connectors support cooling fans. Connect the fan cables to the fan connectors on the motherboard, ensuring that the black wire of each cable matches the ground pin of the connector.



- DO NOT forget to connect the fan cables to the fan connectors. Insufficient air flow inside the system may damage the motherboard components.
- These are not jumpers! DO NOT place jumper caps on the fan connectors!
- All connectors feature the ASUS Smart Fan technology.

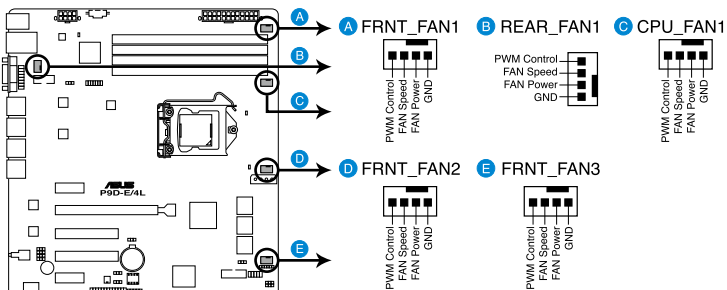

P9D-E/4L FAN connectors

8. Serial General Purpose Input/Output connector (6-1 pin SGPIO1)

The SGPIO 1 connectors are used for the Intel Rapid Storage Technology Enterprise SGPIO interface that controls the LED pattern generation, device information, and general purpose data.

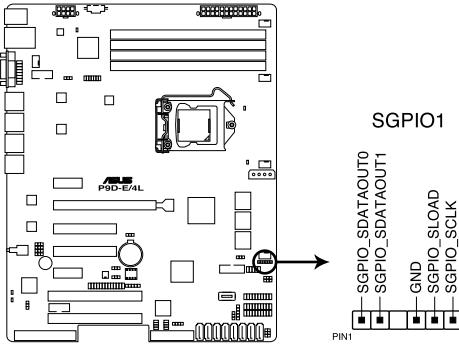

P9D-E/4L SGPIO connector



The PSGPIO 1 and PSGPIO 2 connectors only functions when you install an ASUS PIKE RAID card.

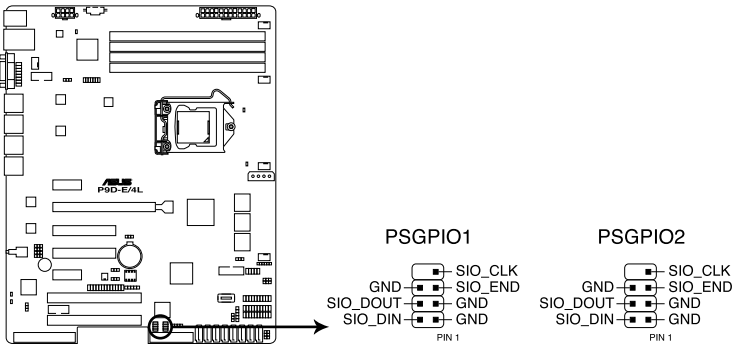

P9D-E/4L PSGPIO1/2 connectors

9. Serial port connectors (10-1 pin COM1/COM2)

These connectors are for the serial COM ports. Connect the serial port module cable to one of these connectors, then install the module to a slot opening at the back of the system chassis.

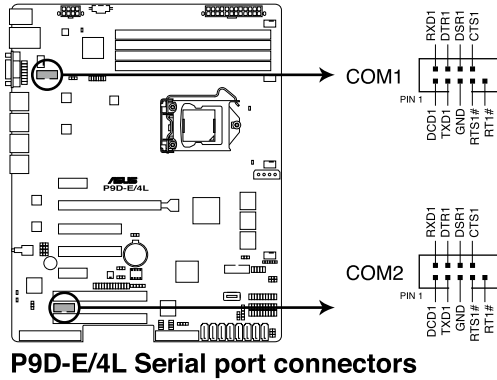

10. Power Supply SMBus connector (5-pin PSUSMB1)

This connector allows you to connect SMBus (System Management Bus) to the power supply unit to read PSU information. Devices communicate with an SMBus host and/or other SMBus devices using the SMBus interface.

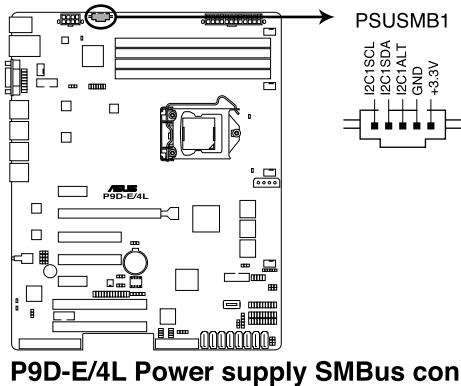

This connector functions only when you install the ASUS ASMB7.

11. Trusted Platform Module connector (20-pin TPM1)

This connector supports a Trusted Platform Module (TPM) system, which can securely store keys, digital certificates, passwords, and data. A TPM system also helps enhance network security, protects digital identities, and ensures platform integrity.

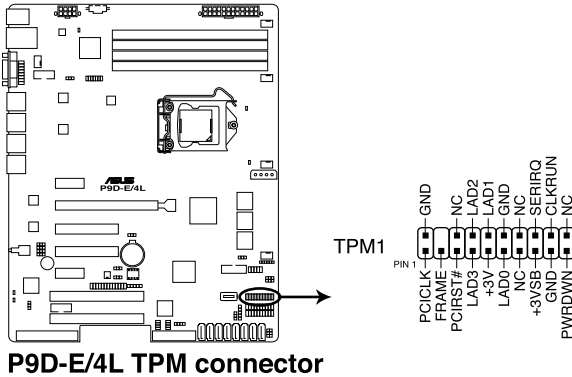

12. SATA DOM power connector (4-pin PWR3)

This 4-pin connector is for 5V power of a certain SATA DOM (Disk on Module) device when using an appropriate cable.

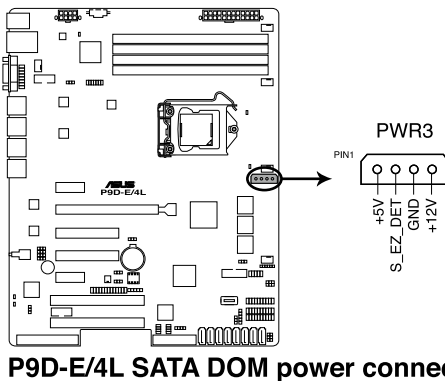

- The SATA DOM power connector is for output power only. It has a maximum output current of 1A.
- Ensure that the power of the SATA DOM device that you will use is less than 1A.

13. LAN34_LED connector (5-1 pin LAN34_LED1)

These LEDs are for Gigabit LAN activity LEDs on the front panel. Connect the LAN LED cable to the backplane for LAN activity indication.

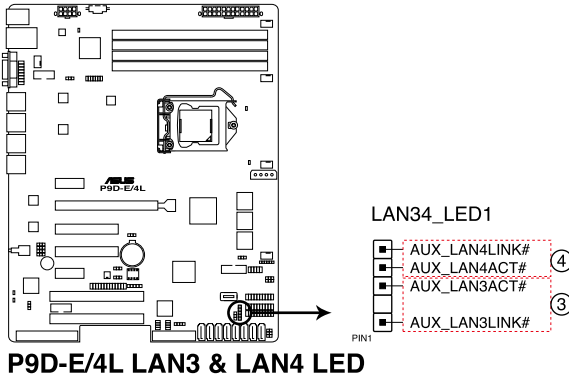

P9D-E/4L LAN3 & LAN4 LED

14. Parallel port connector (26-1 pin LPT1)

This connector is for the parallel port. Connect the parallel port module cable to this connector, then install the module to a slot opening at the back of the system chassis.

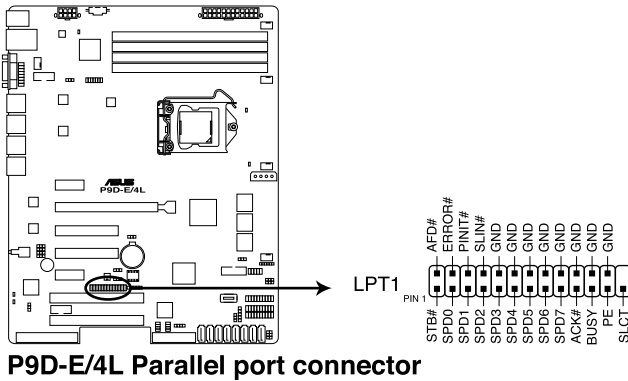

P9D-E/4L Parallel port connector

15. VGA connector (16-1 pin VGA_HDR1)

This connector supports the VGA High Dynamic-Range interface.

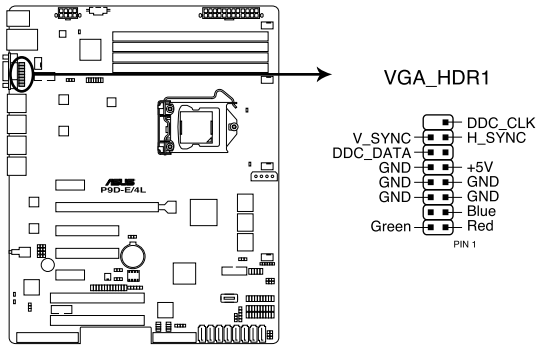

P9D-E/4L VGA connector

16. ATX power connectors (24-pin EATXPWR1, 8-pin EATX12V1)

These connectors are for the ATX power supply plugs. The power supply plugs are designed to fit these connectors in only one orientation. Find the proper orientation and push down firmly until the connectors completely fit.



- DO NOT forget to connect the 24-pin and the 8-pin power plugs otherwise the system will not boot up.
- Use of a power supply unit (PSU) with a higher power output is recommended when configuring a system with more power-consuming devices. The system may become unstable or may not boot up if the power is inadequate.
- This motherboard supports ATX2.0 PSU or later version.
- Ensure that your PSU can provide at least the minimum power required by your system.

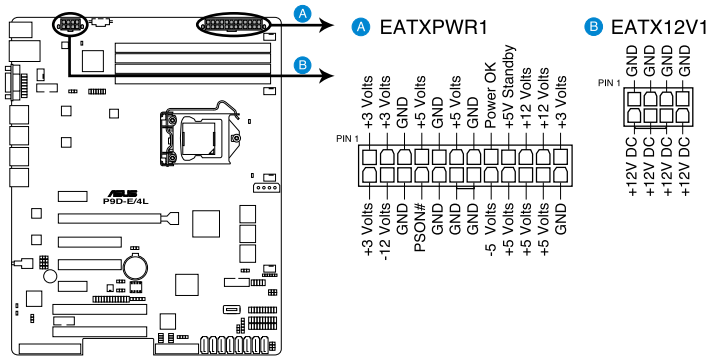

P9D-E/4L ATX power connectors

17. System panel connector (20-1 pin PANEL1)

This connector supports several chassis-mounted functions.

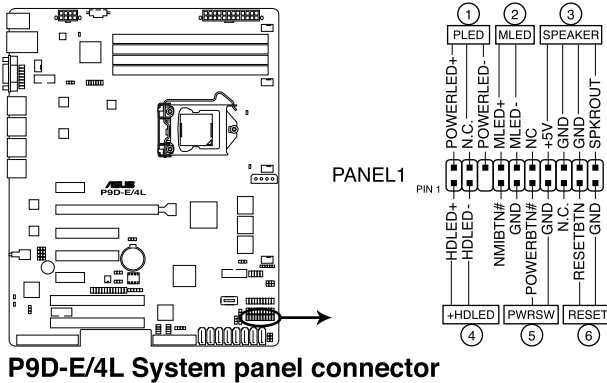

P9D-E/4L System panel connector

1. System power LED (3-pin PLED)

This 3-pin connector is for the system power LED. Connect the chassis power LED cable to this connector. The system power LED lights up when you turn on the system power, and blinks when the system is in sleep mode.

2. Message LED (2-pin MLED)

This 2-pin connector is for the message LED cable that connects to the front message LED. The message LED is controlled by Hardware monitor to indicate an abnormal event occurrence.

3. System warning speaker (4-pin SPEAKER)

This 4-pin connector is for the chassis-mounted system warning speaker. The speaker allows you to hear system beeps and warnings.

4. Hard disk drive activity LED (2-pin +HLED)

This 2-pin connector is for the HDD Activity LED. Connect the HDD Activity LED cable to this connector. The IDE LED lights up or flashes when data is read from or written to the HDD.

5. Power button/soft-off button (2-pin PWRSW)

This connector is for the system power button. Pressing the power button turns the system on or puts the system in sleep or soft-off mode depending on the BIOS settings. Pressing the power switch for more than four seconds while the system is ON turns the system OFF.

6. Reset button (2-pin RESET)

This 2-pin connector is for the chassis-mounted reset button for system reboot without turning off the system power.

18. Auxiliary panel connector (20-2 pin AUX_PANEL1)

This connector is for additional front panel features including front panel SMB, Locator LED and switch, chassis intrusion, and LAN LEDs.

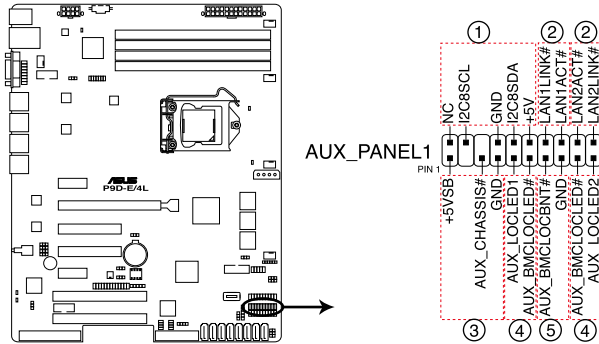

P9D-E/4L Auxiliary panel connector

1. Front panel SMB (6-1 pin FPSMB)

These LEDs connect the front panel SMBus cable.

2. LAN activity LED (2-pin LAN1LINK and 2-pin LAN2LINK)

These LEDs are for Gigabit LAN activity LEDs on the front panel.

3. Chassis intrusion (4-1 pin AUX_CHASSIS)

These LEDs are for the intrusion detection feature for chassis with intrusion sensor or microswitch. When you remove any chassis component, the sensor triggers and sends a high-level signal to these LEDs to record a chassis intrusion event. The default setting is short CASEOPEN and GND pin by jumper cap to disable the function.

4. Locator LED (2-pin AUX_LOCLEDD1 and 2-pin AUX_LOCLEDD2)

These LEDs are for the Locator LED1 and LED2 on the front panel. Connect the Locator LED cables to these 2-pin connector. The LEDs will light up when the Locator button is pressed.

5. Locator Button/Switch (2-pin AUX_BMCLCLOBNT)

These LEDs are for the locator button on the front panel. This button queries the state of the system locator.

Chapter 3: Powering Up

Chapter summary

This chapter describes the power up sequence, and ways of shutting down the system. This chapter contains the following sections:

3.1	Starting up for the first time.....	3-3
3.2	Powering off the computer.....	3-4

3.1 Starting up for the first time

1. After making all the connections, replace the system case cover.
2. Be sure that all switches are off.
3. Connect the power cord to the power connector at the back of the system chassis.
4. Connect the power cord to a power outlet that is equipped with a surge protector.
5. Turn on the devices in the following order:
 - a. Monitor
 - b. External storage devices (starting with the last device on the chain)
 - c. System power
6. After applying power, the system power LED on the system front panel case lights up. For systems with ATX power supplies, the system LED lights up when you press the ATX power button. If your monitor complies with “green” standards or if it has a “power standby” feature, the monitor LED may light up or switch between orange and green after the system LED turns on.

The system then runs the power-on self-test or POST. While the tests are running, the BIOS beeps or additional messages appear on the screen. If you do not see anything within 30 seconds from the time you turned on the power, the system may have failed a power-on test. Check the jumper settings and connections or call your retailer for assistance.

7. At power on, hold down the key to enter the BIOS Setup. Follow the instructions in Chapter 4.

3.2 Powering off the computer

3.2.1 Using the OS shut down function

Using Windows® Server 2008 R2:

1. Click the **Start** button, move the cursor to the triangle on the right of Log off, then click **Shut Down**.
2. From the **Shutdown Event Tracker**, select the option that best describes why you want to shut down the computer.
3. Ensure that the **Planned** check box is checked.
4. If necessary, key in comments.
5. Click **OK**.

Using Windows® Server 2012:

1. Press <Ctrl>+<Alt>+.
2. Click on the Power icon on the lower right side of the screen.
3. Select **Shut down**.
4. In the Shutdown Event Tracker, select the **Other (Planned)** option in the selection lists. Otherwise, select the option that best describes why you want to shut down the computer.
5. Click **Continue**.

3.2.2 Using the dual function power switch

While the system is ON, press the power switch for less than four seconds to put the system to sleep mode or to soft-off mode, depending on the BIOS setting.



Pressing the power switch for more than four seconds lets the system enter the soft-off mode regardless of the BIOS setting.

Chapter 4: BIOS setup

4

Chapter summary

This chapter tells how to change the system settings through the BIOS Setup menus. Detailed descriptions of the BIOS parameters are also provided.

This chapter contains the following sections:

4.1	Managing and updating your BIOS	4-3
4.2	BIOS setup program	4-7
4.3	Main menu	4-10
4.4	Advanced menu	4-11
4.5	Event Logs menu	4-31
4.6	Boot menu	4-32
4.7	Monitor menu	4-35
4.8	Security	4-36
4.9	Tool menu	4-39
4.10	Exit menu	4-39

4.1 Managing and updating your BIOS

The following utilities allow you to manage and update the motherboard Basic Input/Output System (BIOS) setup:

1. **ASUS CrashFree BIOS 3**

To recover the BIOS using a bootable USB flash disk drive when the BIOS file fails or gets corrupted.

2. **ASUS EzFlash**

Updates the BIOS using a USB flash disk.

3. **BUPDATER**

Updates the BIOS in DOS mode using a bootable USB flash disk drive.

Refer to the corresponding sections for details on these utilities.



Save a copy of the original motherboard BIOS file to a bootable USB flash disk drive in case you need to restore the BIOS in the future. Copy the original motherboard BIOS using the BUPDATER utility.

4.1.1 **ASUS CrashFree BIOS 3 utility**

The ASUS CrashFree BIOS 3 is an auto recovery tool that allows you to restore the BIOS file when it fails or gets corrupted during the updating process. You can update a corrupted BIOS file using a USB flash drive that contains the updated BIOS file.



Prepare a USB flash drive containing the updated motherboard BIOS before using this utility.

Recovering the BIOS from a USB flash drive

To recover the BIOS from a USB flash drive:

1. Insert the USB flash drive with the original or updated BIOS file to one USB port on the system.
2. The utility will automatically recover the BIOS. It resets the system when the BIOS recovery finished.



DO NOT shut down or reset the system while recovering the BIOS! Doing so would cause system boot failure!



The recovered BIOS may not be the latest BIOS version for this motherboard. Visit the ASUS website at www.asus.com to download the latest BIOS file.

4.1.2 ASUS EzFlash Utility

The ASUS EzFlash Utility feature allows you to update the BIOS using a USB flash disk without having to use a DOS-based utility.



Download the latest BIOS from the ASUS website at www.asus.com before using this utility.



The succeeding BIOS screens are for reference only. The actual BIOS screen displays may not be the same as shown.

To update the BIOS using EzFlash Utility:

1. Insert the USB flash disk that contains the latest BIOS file to the USB port.
2. Enter the BIOS setup program. Go to the **Tool** menu to select **ASUS EzFlash Utility** and press <Enter> to enable it.

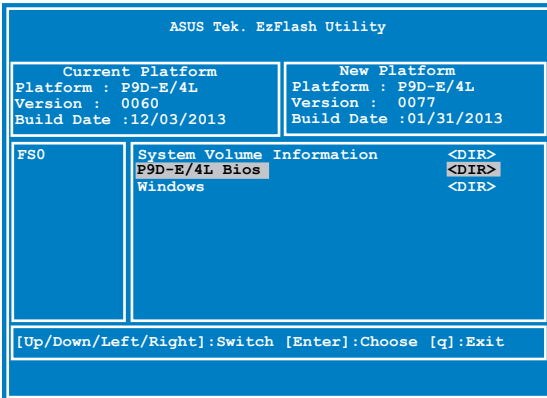

3. Press <Tab> to switch to the **Drive** field.
4. Press the Up/Down arrow keys to find the USB flash disk that contains the latest BIOS then press <Enter>.
5. Press <Tab> to switch to the **Folder Info** field.
6. Press the Up/Down arrow keys to find the BIOS file then press <Enter>.

7. Reboot the system when the update process is done.



- This function can support devices such as a USB flash disk with FAT 32/16 format and single partition only.
- DO NOT shut down or reset the system while updating the BIOS to prevent system boot failure!



Ensure to load the BIOS default settings to ensure system compatibility and stability. Press <F5> and select **Yes** to load the BIOS default settings.

4.1.3 BUPDATER utility



The succeeding BIOS screens are for reference only. The actual BIOS screen displays may not be the same as shown.

The BUPDATER utility allows you to update the BIOS file in DOS environment using a bootable USB flash disk drive with the updated BIOS file.

Updating the BIOS file

To update the BIOS file using the BUPDATER utility:

1. Visit the ASUS website at www.asus.com and download the latest BIOS file for the motherboard. Save the BIOS file to a bootable USB flash disk drive.
2. Download the BUPDATER utility (BUPDATER.exe) from the ASUS support website at support.asus.com to the bootable USB flash disk drive you created earlier.
3. Boot the system in DOS mode, then at the prompt, type:

```
BUPDATER /i [filename] .CAP
```

where [filename] is the latest or the original BIOS file on the bootable USB flash disk drive, then press <Enter>.

```
A:\>BUPDATER /i[file name]CAP
```

The utility verifies the file, then starts updating the BIOS file.

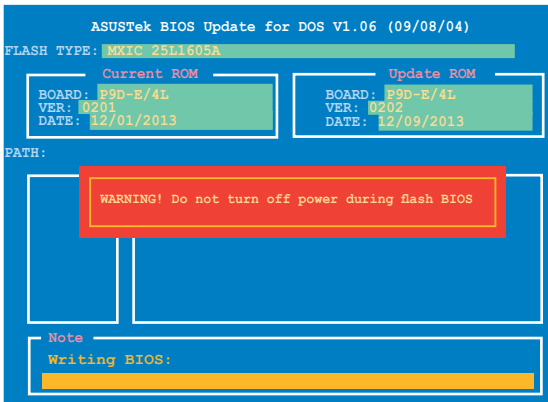

DO NOT shut down or reset the system while updating the BIOS to prevent system boot failure!

The utility returns to the DOS prompt after the BIOS update process is completed.

4. Reboot the system from the hard disk drive.



4.2 BIOS setup program

This motherboard supports a programmable firmware chip that you can update using the provided utility described in section 4.1 **Managing and updating your BIOS**.

Use the BIOS Setup program when you are installing a motherboard, reconfiguring your system, or prompted to “Run Setup.” This section explains how to configure your system using this utility.

Even if you are not prompted to use the Setup program, you can change the configuration of your computer in the future. For example, you can enable the security password feature or change the power management settings. This requires you to reconfigure your system using the BIOS Setup program so that the computer can recognize these changes and record them in the CMOS RAM of the firmware chip.

The firmware chip on the motherboard stores the Setup utility. When you start up the computer, the system provides you with the opportunity to run this program. Press during the Power-On Self-Test (POST) to enter the Setup utility; otherwise, POST continues with its test routines.

If you wish to enter Setup after POST, restart the system by pressing <Ctrl>+<Alt>+, or by pressing the reset button on the system chassis. You can also restart by turning the system off then back on. Do this last option only if the first two failed.

The Setup program is designed to make it as easy to use as possible. Being a menu-driven program, it lets you scroll through the various sub-menus and make your selections from the available options using the navigation keys.



-
- The default BIOS settings for this motherboard apply for most conditions to ensure optimum performance. If the system becomes unstable after changing any BIOS settings, load the default settings to ensure system compatibility and stability. Press <F5> and select **Yes** to load the BIOS default settings.
 - The BIOS setup screens shown in this section are for reference purposes only, and may not exactly match what you see on your screen.
 - Visit the ASUS website (www.asus.com) to download the latest BIOS file for this motherboard.
-

4.2.1 BIOS menu screen

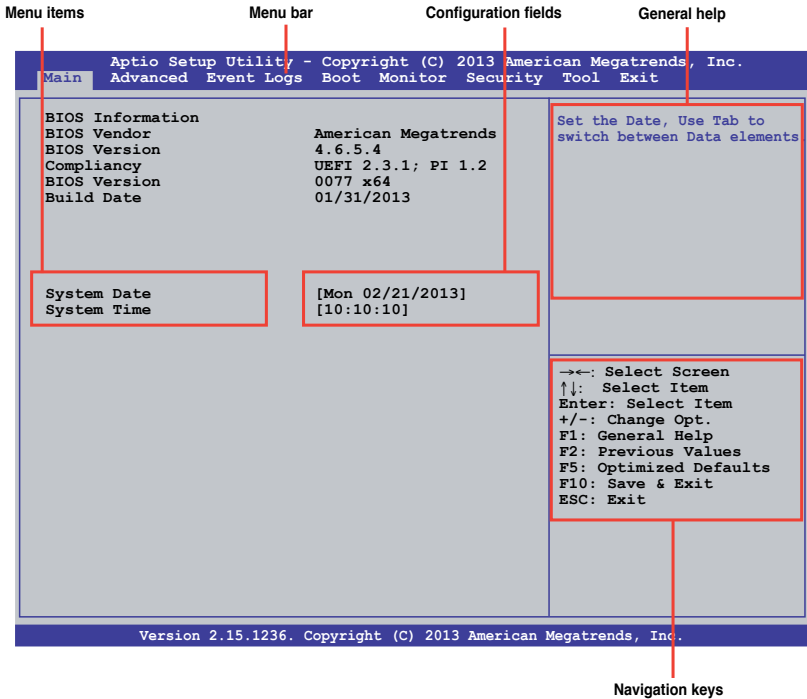

4.2.2 Menu bar

The menu bar on top of the screen has the following main items:

- Main** For changing the basic system configuration
- Advanced** For changing the advanced system settings
- Event Logs** For changing the event log settings
- Boot** For changing the system boot configuration
- Monitor** For displaying the system temperature, power status, and changing the fan settings
- Security** For changing the security settings
- Tool** For configuring options for special functions
- Exit** For selecting the exit options

To select an item on the menu bar, press the right or left arrow key on the keyboard until the desired item is highlighted.

4.2.3 Menu items

The highlighted item on the menu bar displays the specific items for that menu. For example, selecting **Main** shows the Main menu items. The other items (Advanced, Event Logs, Boot, Monitor, Security, Tool, and Exit) on the menu bar have their respective menu items.

4.2.4 Submenu items

A solid triangle before each item on any menu screen means that the item has a submenu. To display the submenu, select the item and press <Enter>.

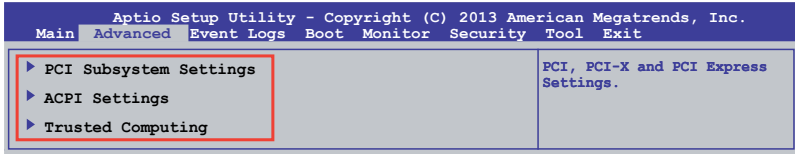

4.2.5 Navigation keys

At the bottom right corner of a menu screen are the navigation keys for the BIOS setup program. Use the navigation keys to select items in the menu and change the settings.

4.2.6 General help

At the top right corner of the menu screen is a brief description of the selected item.

4.2.7 Configuration fields

These fields show the values for the menu items. If an item is user-configurable, you can change the value of the field opposite the item. You cannot select an item that is not user-configurable. A configurable field is enclosed in brackets, and is highlighted when selected. To change the value of a field, select it and press <Enter> to display a list of options.

4.2.8 Pop-up window

Select a menu item and press <Enter> to display a pop-up window with the configuration options for that item.

4.2.9 Scroll bar

A scroll bar appears on the right side of a menu screen when there are items that do not fit on the screen. Press the Up/Down arrow keys or <Page Up> /<Page Down> keys to display the other items on the screen.

4.3 Main menu

When you enter the BIOS Setup program, the Main menu screen appears. The Main menu provides you an overview of the basic system information, and allows you to set the system date and time.

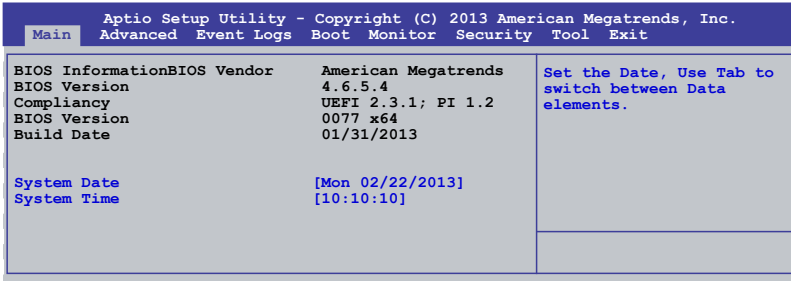

4.3.1 System Date

Allows you to set the system date to [Day mm/dd/yyyy].

Where:

Day = Day of the week

mm = month (numeric value)

dd = day (numeric value)

yyyy = year (numeric value)

4.3.2 System Time

Allows you to set the system time to [hh/mm/ss].

Where:

hh = hour (numeric value)

mm = minutes (numeric value)

ss = seconds (numeric value)

4.4 Advanced menu

The Advanced menu items allow you to change the settings for the CPU and other system devices.



Take caution when changing the settings of the Advanced menu items. Incorrect field values can cause the system to malfunction.

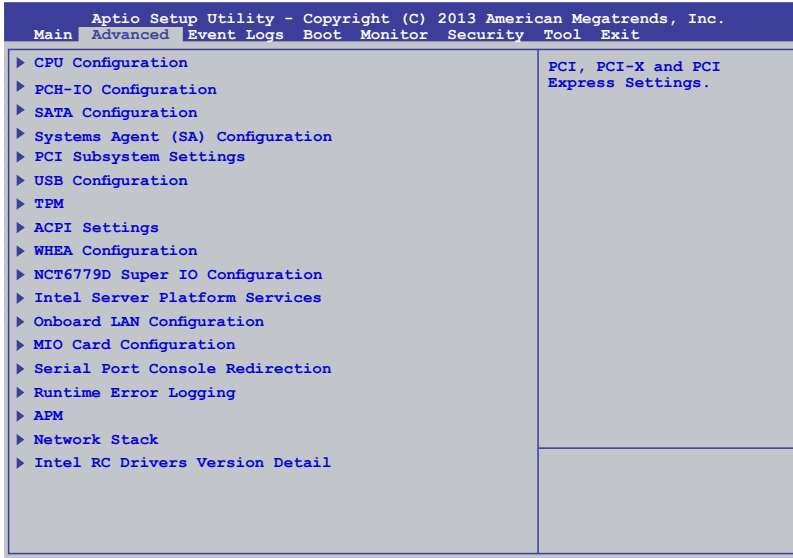

4.4.1 CPU Configuration

The items in this menu show the CPU-related information that the BIOS automatically detects. Some items may not appear if your CPU does not support the related functions.

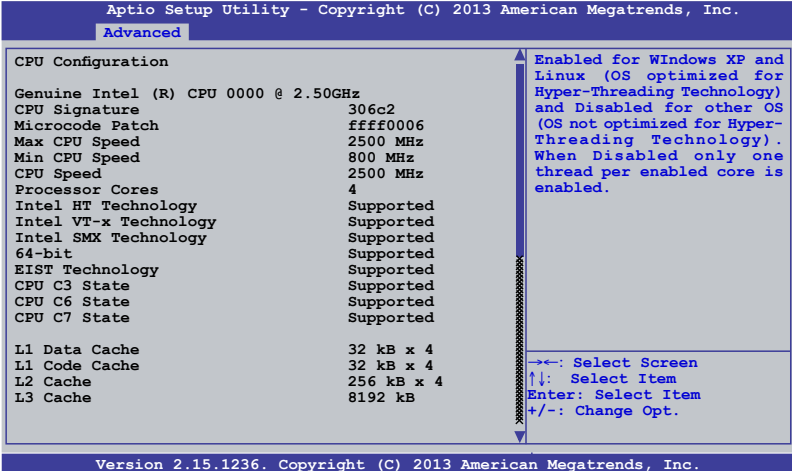

Aptio Setup Utility - Copyright (C) 2013 American Megatrends, Inc.

Advanced

CPU Configuration

Genuine Intel (R) CPU 0000 @ 2.50GHz	
CPU Signature	306c2
Microcode Patch	ffff0006
Max CPU Speed	2500 MHz
Min CPU Speed	800 MHz
CPU Speed	2500 MHz
Processor Cores	4
Intel HT Technology	Supported
Intel VT-x Technology	Supported
Intel SMX Technology	Supported
64-bit	Supported
EIST Technology	Supported
CPU C3 State	Supported
CPU C6 State	Supported
CPU C7 State	Supported
L1 Data Cache	32 kB x 4
L1 Code Cache	32 kB x 4
L2 Cache	256 kB x 4
L3 Cache	8192 kB

Enabled for WInDows XP and Linux (OS optimized for Hyper-Threading Technology) and Disabled for other OS (OS not optimized for Hyper-Threading Technology). When Disabled only one thread per enabled core is enabled.

→←: Select Screen
↑↓: Select Item
Enter: Select Item
+/-: Change Opt.

Version 2.15.1236. Copyright (C) 2013 American Megatrends, Inc.

Navigate to the second page of the screen to see the rest of items in this menu by pressing the Up or Down arrow keys.



To quickly go to the last item of the second page, press the **Page Down** button. Press the **Page Up** button to go back to the first item in the first page.

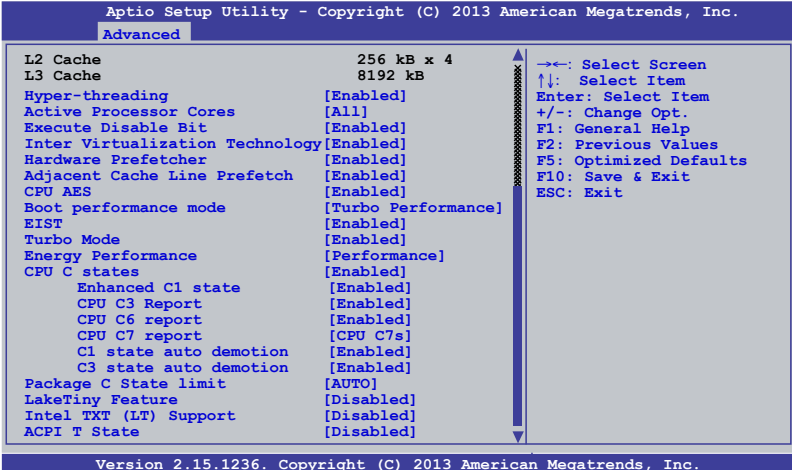

Aptio Setup Utility - Copyright (C) 2013 American Megatrends, Inc.

Advanced

L2 Cache	256 kB x 4
L3 Cache	8192 kB
Hyper-threading	[Enabled]
Active Processor Cores	[All]
Execute Disable Bit	[Enabled]
Inter Virtualization Technology	[Enabled]
Hardware Prefetcher	[Enabled]
Adjacent Cache Line Prefetch	[Enabled]
CPU AES	[Enabled]
Boot performance mode	[Turbo Performance]
EIST	[Enabled]
Turbo Mode	[Enabled]
Energy Performance	[Performance]
CPU C states	[Enabled]
Enhanced C1 state	[Enabled]
CPU C3 Report	[Enabled]
CPU C6 report	[Enabled]
CPU C7 report	[CPU C7s]
C1 state auto demotion	[Enabled]
C3 state auto demotion	[Enabled]
Package C State limit	[AUTO]
LakeTiny Feature	[Disabled]
Intel TXT (LT) Support	[Disabled]
ACPI T State	[Disabled]

→←: Select Screen
↑↓: Select Item
Enter: Select Item
+/-: Change Opt.
F1: General Help
F2: Previous Values
F5: Optimized Defaults
F10: Save & Exit
ESC: Exit

Version 2.15.1236. Copyright (C) 2013 American Megatrends, Inc.

Hyper-threading [Enabled]

Allows you to enable or disable the Intel Hyper-Threading Technology function.

Configuration options: [Enabled] [Disabled]

Active Processor Cores [All]

Allows you to choose the number of CPU cores to activate in each processor package.

Configuration options: [All] [1] [2] [3]

Execute Disable Bit [Enabled]

Allows you to enable or disable the XD feature that can prevent certain classes of malicious buffer overflow attacks when combined with a supporting OS. Configuration options: [Enabled][Disabled]

Intel Virtualization Technology [Enabled]

Allows you to utilize the additional hardware capabilities provided by Vanderpool Technology. Configuration options: [Enabled] [Disabled]

Hardware Prefetcher [Enabled]

Allows you to enable or disable the Mid Level Cache (L2) streamer. Configuration options: [Enabled] [Disabled]

Adjacent Cache Line Prefetch [Enabled]

Allows you to enable or disable the Mid Level Cache (L2) prefetching of adjacent cache lines. Configuration options: [Enabled] [Disabled]

CPU AES [Enabled]

Allows you to enable or disable the CPU Advance Encryption Standard instructions. Configuration options: [Disabled] [Enabled]

Boot performance mode [Turbo Performance]

This item allows you to select the performance state that the BIOS will set before OS handoff. Configuration options: [Max Non-Turbo Performance] [Max Battery] [Turbo Performance]

EIST [Enabled]

Allows you to enable or disable the Enhanced Intel SpeedStep Technology (EIST).

Configuration options: [Enabled] [Disabled]

Turbo Mode [Enabled]

This item appears only when you set the EIST item to [Enabled]. This allows you to enable or disable the Intel® Turbo Mode Technology.

Configuration options: [Enabled] [Disabled]

Energy Performance [Performance]

Allows you to optimize between performance and power savings. Configuration options: [Performance] [Balanced Performance] [Balanced Energy] [Energy Efficient]

CPU C states [Enabled]

Allows you to enable or disable the CPU C states. Configuration options: [Enabled] [Disabled]



This following items appears only when you set the CPU C states to [Enabled].

Enhanced C1 State [Enabled]

This item allows you to enable or disable the Enhanced C1 state. Configuration options: [Enabled] [Disabled]

CPU C3 Report [Enabled]

Allows you to enable or disable the CPU C3 report to OS. Configuration options: [Enabled] [Disabled]

CPU C6 Report [Enabled]

Allows you to enable or disable the CPU C6 report to OS. Configuration options: [Disabled] [Enabled]

CPU C7 Report [CPU C7s]

Allows you to enable or disable the CPU C7 report to OS. Configuration options: [Disabled] [CPU C7] [CPU C7s]

C1 state auto demotion [Enabled]

Allows you to enable or disable the demotion of the C3/C6/C7 request to C1 based on uncore auto-demote information. Configuration options: [Disabled] [Enabled]

C3 state auto demotion [Enabled]

Allows you to enable or disable the demotion of the C6/C7 request to C3 based on uncore auto-demote information. Configuration options: [Disabled] [Enabled]

Package C State limit [AUTO]

Allows you set the Package C State limit to AUTO. Configuration options: [C0/C1] [C2] [C3] [C6] [C7] [C7s] [AUTO]

LakeTiny Feature [Disabled]

Allows you enable or disable LakeTiny for C state configuration. Configuration options: [Disabled] [Enabled]

Intel TXT (LT) Suppot [Disabled]

Allows you to enable or disable the Intel TXT (LT) support. Configuration options: [Disabled] [Enabled]

ACPI T State [Disabled]

Allows you to enable or disable the ACPI T state. Configuration options: [Disabled] [Enabled]

4.4.2 PCH-IO Configuration

Allows you to configure PCH parameters.

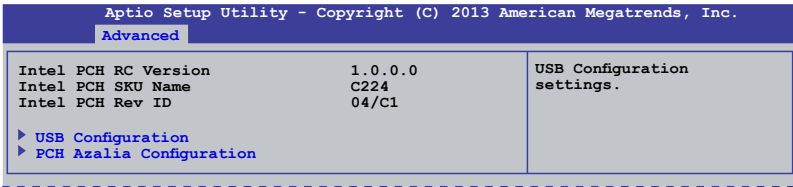

USB Configuration

Allows you to set the USB Configuration settings.

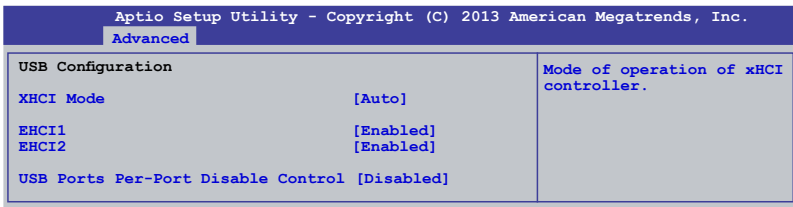

XHCI Mode [Auto]

Allows you to set the mode of operation of the xHCI controller. Configuration options: [Auto] [Enabled] [Disabled]

EHCI1 / EHCI2 [Enabled]

Allows you to control the USB EHCI (USB 2.0) functions. One EHCI controller must always be enabled. Configuration options: [Auto] [Disabled] [Enabled]

USB Ports Per-Port Disable Control [Disabled]

Allows you to control the disabling of the USB ports (0-13). Configuration options: [Auto] [Disabled] [Enabled]

USB Port #0-#13 Disable [Enabled]

This item only appears when you set the USB Ports Per-Port Disable Control to [Enabled]. This item allows you to control the disabling of each of the USB ports (0-13). Configuration options: [Disabled] [Enabled]

PCH Azalia Configuration

Allows you to control the detection of the Azalia device. Configuration options: [Auto] [Disabled]

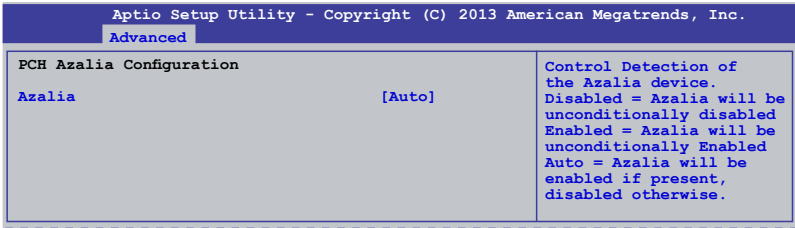

4.4.3 SATA Configuration

While entering Setup, the BIOS automatically detects the presence of SATA devices. The SATA Port items show **Not Present** if no SATA device is installed to the corresponding SATA port.

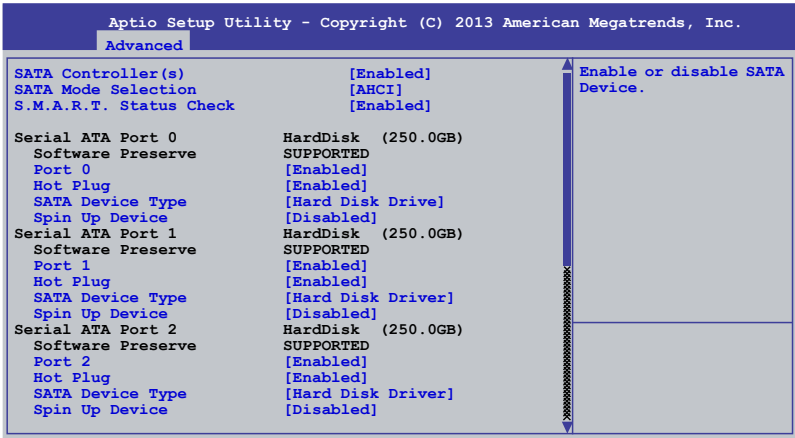

SATA Controller(s) [Enabled]

This allows you to enable or disable the SATA Device. Configuration options: [Enabled] [Disabled]

SATA Mode Selection [AHCI]

This allows you to choose how SATA controller(s) should operate. Configuration options: [AHCI] [IDE] [RAID]

S.M.A.R.T. Status Check [Enabled]

Self-Monitoring, Analysis, and Reporting Technology (S.M.A.R.T.) is a monitor system. When read/write of your hard disk errors occur, this feature allows the hard disk to report warning messages during the POST. Configuration options: [Enabled] [Disabled]

Compatible Mode [Disabled]

This item only appears when you set the SATA Mode Selection to [IDE]. This item allows you to enable or disable the Compatible mode. Configuration options: [Disabled] [Enabled]

Aptio Setup Utility - Copyright (C) 2013 American Megatrends, Inc.		
Advanced		
SATA Controller(s)	[Enabled]	Determines how SATA controller(s) operate.
SATA Mode Selection	[IDE]	
Compatible Mode	[Disabled]	
S.M.A.R.T. Status Check	[Enabled]	
Serial SATA Port 0	HardDisk (250.0GB)	
Software Preserve	SUPPORTED	
Serial SATA Port 1	HardDisk (250.0GB)	
Software Preserve	SUPPORTED	
Serial SATA Port 2	HardDisk (250.0GB)	
Software Preserve	SUPPORTED	
Serial SATA Port 3	HardDisk (250.0GB)	
Software Preserve	SUPPORTED	
Serial SATA Port 4	HardDisk (250.0GB)	
Software Preserve	SUPPORTED	
Serial SATA Port 5	ASUS DVD-E8 ATAPI	
Software Preserve	SUPPORTED	

4.4.4 System Agent (SA) Configuration

This allows you to change System Agent parameters.

Aptio Setup Utility - Copyright (C) 2013 American Megatrends, Inc.		
Advanced		
System Agent Bridge Name	Haswell	Check to enable VT-d function on MCH.
System Agent RC Version	1.0.0.0	
VT-d Capability	Supported	
VT-d	[Enabled]	
Enable NB Card	[Disabled]	
BDAT ACPI Table Support	[Disabled]	
VGA Priority	[Offboard]	
▶ Memory Configuration		

VT-d [Enabled]

This allows you enable or disable the VT-d function on MCH. Configuration options: [Enabled] [Disabled]

Enable NB CRID [Disabled]

This allows you enable or disable the NB CRID WorkAround. Configuration options: [Enabled] [Disabled]

BDAT ACPI Table Support [Disabled]

This allows you enable or disable the support for the BDAT ACPI table. Configuration options: [Enabled] [Disabled]

VGA Priority [Offboard]

This allows you to prioritize between the onboard and offboard video device to be found. Configuration options: [Onboard] [Offboard]

Memory Configuration

This allows you to change memory information settings.

Aptio Setup Utility - Copyright (C) 2013 American Megatrends, Inc.	
Advanced	
Memory Information	Maximum Memory Frequency Selections in MHz.
Memory RC Version	1.0.0.0
Memory Frequency	1067 MHz
Usage Memory	1024 MB (DDR3)
DIMM A1	Not Present
DIMM A2	1024 MB (DDR3)
DIMM A3	Not Present
DIMM A4	Not Present
CAS Latency (tCL)	7
Minimum delay time	
CAS to RAS (tRCdmin)	7
Row Precharge (tRPmin)	7
Active to Precharge (tRASmin)	20
Memory Frequency Limiter	[Auto]
ECC Support	[Enabled]
Memory Scrambler	[Enabled]
Memory Remap	[Enabled]
GDXC Support	[Disabled]

Memory Frequency Limiter [Auto]

This allows you to set the memory frequency in MHz. Configuration options: [Auto] [1333] [1600]

ECC Support [Enabled]

This allows you to enable or disable the DDR ECC support. Configuration options: [Enabled] [Disabled]

Memory Scrambler [Enabled]

This allows you to enable or disable the Memory Scrambler support. Configuration options: [Enabled] [Disabled]

Memory Remap [Enabled]

This allows you to enable or disable the Memory Remap above 4G. Configuration options: [Enabled] [Disabled]

GDXC Support [Disabled]

This allows you to enable or disable the GDXC feature. Configuration options: [Enabled] [Disabled]

4.4.5 PCI Subsystem Settings

Allows you to configure PCI, PCI-X, and PCI Express Settings.

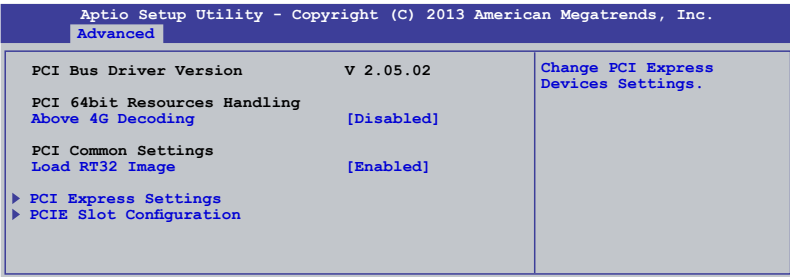

Above 4G Decoding [Disabled]

This item allows you to enable or disable 64-bit capable devices to be decoded in above 4G Address Space if your system supports 64-bit PCI decoding.
Configuration Options: [Disabled][Enabled]

Load RT32 Image [Enabled]

Allows you to enable or disable the RT32 Image Loading. Configuration Options: [Disabled][Enabled]

PCI Express Settings

Allows you to change the settings of the PCI Express Devices.

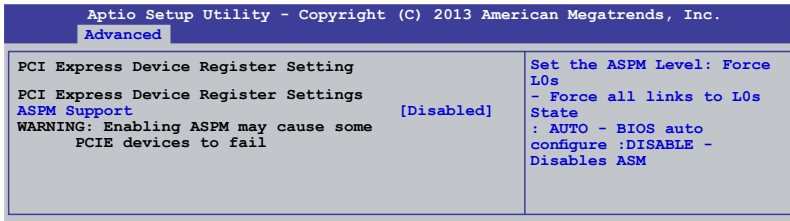

ASPM Support [Disabled]

This item allows you to enable or disable support to Active State Power Management (ASPM). ASPM is a power management protocol that is used to extend battery life. Configuration options:
[Disabled] Disables ASMP
[Auto] BIOS auto configure
[Force L0s] Force all links to L0s State

PCIe Slot Configuration

Allows you to perform PCIe slot configurations.

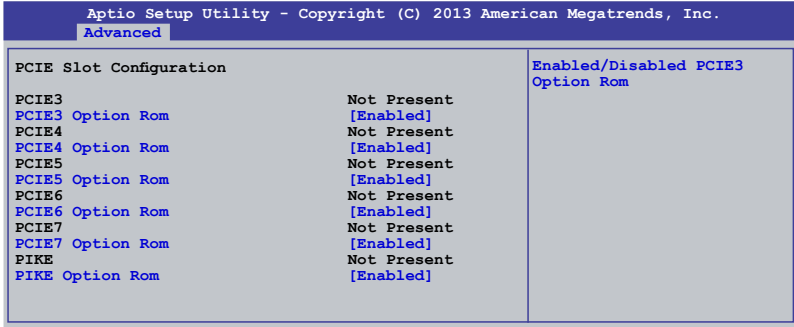

PCIe Slot Configuration		Enabled/Disabled PCIe3 Option Rom
PCIe3	Not Present	
PCIe3 Option Rom	[Enabled]	
PCIe4	Not Present	
PCIe4 Option Rom	[Enabled]	
PCIe5	Not Present	
PCIe5 Option Rom	[Enabled]	
PCIe6	Not Present	
PCIe6 Option Rom	[Enabled]	
PCIe7	Not Present	
PCIe7 Option Rom	[Enabled]	
PIKE	Not Present	
PIKE Option Rom	[Enabled]	

PCIe Option Rom 3 - 7 [Enabled]

Allows you to enable or disable the PCIe slots. Configuration Options:
[Disabled][Enabled]

PIKE Option Rom [Enabled]

Allows you to enable or disable the PIKE Option Rom. Configuration Options:
[Disabled][Enabled]

4.4.6 USB Configuration

This allows you to make changes on the configuration settings of the USB.

Aptio Setup Utility - Copyright (C) 2013 American Megatrends, Inc.	
Advanced	
USB Configuration	Enables Legacy USB support. AUTO option disables legacy support if no USB devices are connected. DISABLE option will keep USB devices available only for EFI applications.
USB Devices 1 mouse, 2 Hubs	
Legacy USB Support	[Enabled]
USB3.0 Support	[Enabled]
XHCI Hand-off	[Enabled]
EHCI Hand-off	[Disabled]
USB Mass Storage Driver Support	[Enabled]
Port 60/64 Emulation	[Enabled]
USB hardware delays and time-outs:	
USB transfer time-out	[20 sec]
Device reset time-out	[20 sec]
Device power-up delay	[Auto]



The **USB Devices** item shows the auto-detected values. If no USB device is detected, the item shows **None**.

Legacy USB Support [Enabled]

Allows you to enable or disable the support for legacy USB devices. Setting to [Auto] allows the system to detect the presence of USB devices at startup. If detected, the USB controller legacy mode is enabled. If no USB device is detected, the legacy USB support is disabled. Configuration options: [Disabled] [Enabled] [Auto]

USB3.0 Support [Enabled]

Enables or disables the USB3.0 (XHCI) controller support. Configuration options: [Disabled] [Enabled]

XHCI Hand-off [Enabled]

This functions as a workaround for OSES without XHCI hand-off support. Configuration options: [Disabled] [Enabled]

EHCI Hand-off [Enabled]

This functions as a workaround for OSES without EHCI hand-off support. Configuration options: [Disabled] [Enabled]

USB Mass Storage Driver Support [Enabled]

This allows you to enable or disable the USB Mass Storage driver support. Configuration options: [Disabled] [Enabled]

Port 60/64 Emulation [Enabled]

This allows you to enable the I/O port 60h/64h emulation support. This should be enabled for the complete USB keyboard legacy support for non-USB aware OSES. Configuration options: [Disabled] [Enabled]

USB transfer time-out [20 sec]

Allows you to select the USB transfer time-out value. Configuration options: [1 sec] [5 sec] [10 sec] [20 sec]

Device reset time-out [20 sec]

Allows you to select the USB device reset time-out value. Configuration options: [10 sec] [20 sec] [30 sec] [40 sec]

Device power-up delay [Auto]

This allows you to set the maximum time the device will take before it properly reports itself to the Host Controller. Configuration options: [Auto] [Manual]

4.4.7 TPM

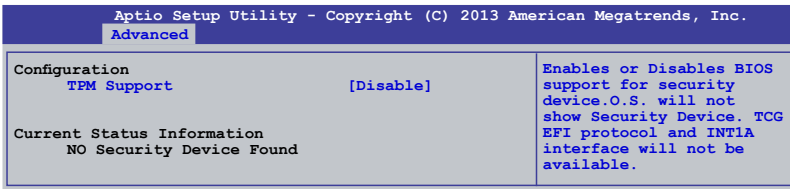

Security Device Support [Disabled]

Allows you to enable or disable BIOS support for security devices. Configuration options: [Disabled] [Enabled]

4.4.8 ACPI Settings

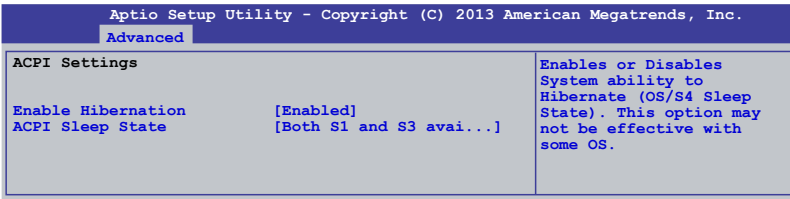

Enable Hibernation [Enabled]

Allows you to enable or disable the Hibernation feature (OS/S4 sleep state). Configuration options: [Disabled] [Enabled]

ACPI Sleep State [Both S1 and S3 available for OS to choose from]

Allows you to set the ACPI Sleep state. Configuration options: [Suspend Disabled] [S1 only (CPU Stop Clock)] [S3 only (Suspend to RAM)] [Both S1 and S3 available for OS to choose from]

4.4.9 WHEA Support

Aptio Setup Utility - Copyright (C) 2013 American Megatrends, Inc.		
Advanced		
WHEA Support	[Enabled]	Enables or disable Windows Hardware Error Architecture.

WHEA [Enabled]

Allows you to enable or disable the Windows® Hardware Error Architecture (WHEA) support. Configuration options: [Disabled] [Enabled]

4.4.10 NCT6779D Super IO Configuration

Aptio Setup Utility - Copyright (C) 2013 American Megatrends, Inc.	
Advanced	
NCT6779D Super IO Configuration	Set Parameters of Serial Port 1 (COM1)
▶ Serial Port 1 Configuration	
▶ Serial Port 2 Configuration	
▶ Parallel Port Configuration	

Serial Port 1/2 Configuration

The sub-items in this menu allows you to set the parameters of the Serial Port 1 (COM1) and the Serial Port 2 (COM2).

Serial Port [Enabled]

Allows you to enable or disable the serial port (COM 1/2). Configuration options: [Enabled] [Disabled]

Change Settings [Auto]

This item only appears when you set the Serial Port to [Enabled]. This item allows you to select the serial port base address. Configuration options:

[Auto]

[IO=3F8h; IRQ=4]

[IO=3F8h; IRQ=3, 4, 5, 6, 7, 10, 11, 12]

[IO=2F8h; IRQ=3, 4, 5, 6, 7, 10, 11, 12]

[IO=3E8h; IRQ=3, 4, 5, 6, 7, 10, 11, 12]

[IO=2E8h; IRQ=3, 4, 5, 6, 7, 10, 11, 12]

[IO=2E8h; IRQ=3, 4, 5, 6, 7, 10, 11, 12]

Parallel Port Configuration

The sub-items in this menu allow you to set the parallel port configuration.

Parallel Port [Enabled]

Allows you to enable or disable the parallel port (LPT/LPTE). Configuration options: [Enabled] [Disabled]

Change Settings [Auto]

Allows you to select the optimal setting for the super IO device.

Configuration options: [Auto] [IO=378h; IRQ=5] [IO=378h: IRQ=5, 6, 7, 10, 11, 12] [IO=278h; IRQ=5, 6, 7, 10, 11, 12] [IO=3BCh; IRQ=5, 6, 7, 10, 11, 12]

Device Mode [STD Printer Mode]

Allows you to select the printer port mode. Configuration options: [STD Printer mode] [SPP Mode] [EPP-1.9 and SPP Mode] [EPP-1.7 and SPP Mode] [ECP Mode] [ECP and EPP 1.9 Mode] [ECP and EPP 1.7 Mode]

4.4.11 Intel Server Platform Services

This item displays the information of the Intel Server Platform Services configured in the system.

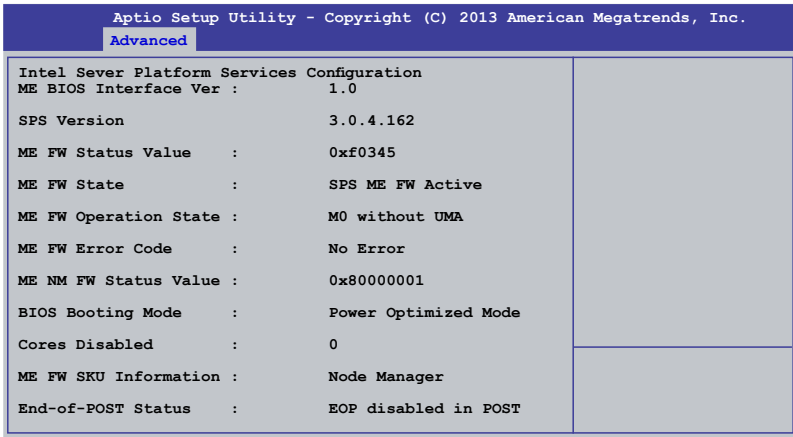

4.4.12 Onboard LAN Configuration

This allows you to change the enable or disable the onboard LAN.

Aptio Setup Utility - Copyright (C) 2013 American Megatrends, Inc.	
Advanced	
Onboard LAN Configuration	INTEL I210 LAN Disable/Enable
INTEL I210 LAN1 MAC:	00:E0:18:10:18:E8
INTEL I210 LAN2 MAC:	00:E0:18:10:18:E9
INTEL I210 LAN3 MAC:	00:E0:18:10:18:EA
INTEL I210 LAN4 MAC:	00:E0:18:10:18:EB
INTEL I210 LAN1 Enable	[Enabled]
INTEL I210 LAN1 OpROM	[PXE]
INTEL I210 LAN2 Enable	[Enabled]
INTEL I210 LAN2 OpROM	[PXE]
INTEL I210 LAN3 Enable	[Enabled]
INTEL I210 LAN3 OpROM	[Disabled]
INTEL I210 LAN4 Enable	[Enabled]
INTEL I210 LAN4 OpROM	[Disabled]

INTEL I210 LAN1 - LAN4 Enable [Enabled]

Allows you to enable or disable the INTEL I210 LAN function in the system.

Configuration Options: [Enabled] [Disabled]

INTEL I210 LAN1/LAN2 OpROM [PXE], INTEL I210 LAN3/LAN4 OpROM [Disabled]

Allows you to launch the Intel I210 LAN OpROM. Configuration options: [Disabled] [PXE] [iSCSI]

4.4.13 MIO Card Configuration

This item allows you to set MIO Card configuration settings.

Aptio Setup Utility - Copyright (C) 2013 American Megatrends, Inc.	
Advanced	
Set MIO Card	MIO Card Type
MIO Card Type	[ALC 892]
Front Panel Type	[AC97]

Front Panel Type [AC97]

Allows you to select the front Panel type of the MIO. Configuration options:

[AC97] [HD]

4.4.14 Serial Port Console Redirection

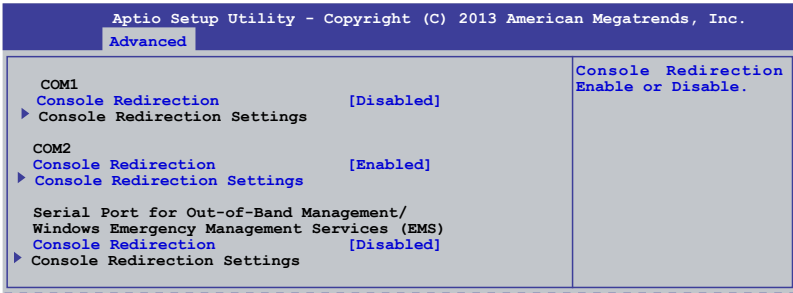

COM1/COM2 Console Redirection [Disabled/Enabled]

Allows you to enable or disable the console redirection feature. Configuration options: [Disabled] [Enabled]



The **Console Redirection Settings** becomes configurable when **Console Redirection** is set to [Enabled].

COM1/COM2 Console Redirection Settings

The settings specify how the host computer and the remote computer (which the user is using) will exchange data. Both computers should have the same or compatible settings.

Terminal Type [VT-UTF8]

Allows you to set the terminal type.

- [VT100] ASCII char set.
- [VT100+] Extends VT100 to support color, function keys, among others
- [VT-UTF8] Uses UTF8 encoding to map Unicode chars onto 1 or more bytes
- [ANSI] Extended ASCII char set

Bits per second [57600]

Selects serial port transmission speed. The speed must be matched on the other side. Long or noisy lines may require lower speeds. Configuration options: [9600] [19200] [38400] [57600] [115200]

Data Bits [8]

Allows you to set the data bits. Configuration options: [7] [8]

Parity [None]

Allows you to select the parity bit. A parity bit is sent with the data bits to detect transmission errors. Configuration options: [None] [Even] [Odd] [Mark] [Space]

Stop Bits [1]

Stop bits indicate the end of a serial data packet. (A start bit indicates the beginning.) The standard setting is 1 stop bit. Communication with slow devices may require more than 1 stop bit. Configuration options: [1] [2]

Flow Control [Hardware RTS/CTS]

Flow control can prevent data loss from buffer overflow. When sending data, if the receiving buffers are full, a “stop” signal can be sent to stop the data flow. Once the buffers are empty, a “start” signal can be sent to re-start the flow. Hardware flow control uses two wires to send start/stop signals. Configuration options: [None] [Hardware RTS/CTS]

VT -UTF8 Combo Key Support [Enabled]

This allows you to enable the VT -UTF8 Combination Key Support for ANSI/VT100 terminals. Configuration options: [Disabled] [Enabled]

Recorder Mode [Disabled]

This allows you to enable or disable the Recorded mode to capture Terminal data. Configuration options: [Disabled] [Enabled]

Resolution 100x31 [Enabled]

This allows you to enable or disable the extended terminal resolution. Configuration options: [Disabled] [Enabled]

Legacy OS Redirection Resolution [80x24]

This allows you to set the number of rows and columns supported on the Legacy OS. Configuration options: [80x24] [80x25]

Putty Keypad [VT100]

This allows you to select the FunctionKey and Keypad on Putty. Configuration options: [VT100] [LINUX] [XTERMR6] [SCO] [ESCN] [VT400]

Redirection After BIOS POST [Bootloader]

This setting allows you to specify if Bootloader is selected than Legacy console redirection. Configuration options: [Always Enable] [Bootloader]

Serial Port for Out-of-Band Management/Windows Emergency Management Services (EMS) Settings



The following items only appears when you set the **Console Redirection** to [Enabled].

Out-of-Band Mgmt Port [COM1]

Allows remote management of a Windows Server OS through a serial port. Configuration options: [COM1] [COM2]

Terminal Type [VT-UTF8]

Allows you to set the terminal type for out-of-band management. Configuration options:

[VT100]	ASCII char set.
[VT100+]	Extends VT100 to support color, function keys, et.
[VT-UTF8]	Uses UTF8 encoding to map Unicode chars onto 1 or more bytes
[ANSI]	Extended ASCII char set

Bits per second [115200]

Selects serial port transmission speed. The speed must be matched on the other side. Long or noisy lines may require lower speeds. Configuration options: [9600] [19200] [38400] [57600] [115200]

Flow Control [None]

Allows you to set the flow control to prevent data loss from buffer overflow. Configuration options: [None] [Hardware RTS/CTS] [Software Xon/Xoff]

4.4.15 Runtime Error Logging Support

Aptio Setup Utility - Copyright (C) 2013 American Megatrends, Inc.		
Advanced		
Runtime Error Logging Support	[Disabled]	Enable/Disable Runtime Error Logging Support.

Runtime Error Logging Support [Disabled]

Allows you to enable or disable the Runtime Error Logging Support. Configuration options: [Disabled] [Enabled]

4.4.16 APM

Allows you to configure the Advance Power Management (APM) settings.

Aptio Setup Utility - Copyright (C) 2013 American Megatrends, Inc.		
Advanced		
Restore AC Power Loss	[Last State]	Specify what state to go to when power is re-applied after a power failure (G3 state).
Power On By PCI	[Disabled]	
Power On By PCIE	[Disabled]	
Power On By RTC	[Disabled]	
EuP Ready	[Disabled]	

Restore AC Power Loss [Last State]

Allows you to set the state the system will go to after an AC power loss. Configuration options: [Power Off] [Power On] [Last State]

Power On By PCI [Disabled]

You can use this option to enable or disable the Wake-on-LAN feature of the Intel® LAN. Configuration options: [Disabled] [Enabled]

Power On By PCIE [Disabled]

This allows you to enable or disable the PCIE devices to generate a wake event. Configuration options: [Disabled] [Enabled]

Power On By RTC [Disabled]

This item allows you to enable or disable RTC to generate a wake event. When set to [Enabled], the items **RTC Alarm Date (Days)** and **Hour/Minute/Second** becomes user-configurable where you can set values.

EuP Ready [Disabled]

This item allows you to switch off some power at S5 to get the system ready for EuP requirement. Configuration options: [Enabled] [Disabled]

4.4.17 Network Stack

Aptio Setup Utility - Copyright (C) 2013 American Megatrends, Inc.		
Advanced		
Network stack	[Disable]	Enable/Disable the network stack (Pxe and UEFI)

Network stack [Disable]

Enables or disables the network stack feature. Configuration options: [Disable]
[Enable]

4.4.18 Intel RC Drivers Version Detail

This item displays the Version String for the Intel RC Drivers.

Aptio Setup Utility - Copyright (C) 2013 American Megatrends, Inc.		
Advanced		
Intel CPU RC Version	1.0.0.0	
Memory RC Version	1.0.0.0	
Intel SA RC Version	1.0.0.0	
Intel PCH RC Version	1.0.0.0	

4.5 Event Logs menu

The Event Logs menu items allow you to change the event log settings and view the system event logs.

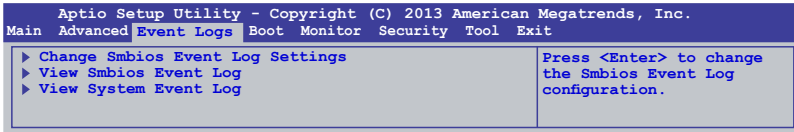

Change Smbios Event Log Settings

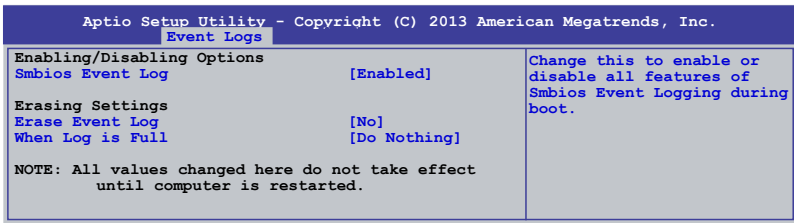

Smbios Event Log [Enabled]

Allows you to enable or disable all features of Smbios event logging during boot.

Configuration options: [Disabled] [Enabled]

Erase Event Log [No]

This item only appears when Smbios Event Log is set to [Enabled]. This item allows you to select the options for erasing Smbios event log. Configuration options: [No] [Yes, Next reset] [Yes, Every reset]

When Log is Full [Do Nothing]

This item only appears when Smbios Event Log is set to [Enabled]. This item allows you to select the options for reaction when the event logs are full. Configuration options: [Do Nothing] [Erase Immediately]

4.6 Boot menu

The items in Boot menu allows you to change the options on how the system will boot.

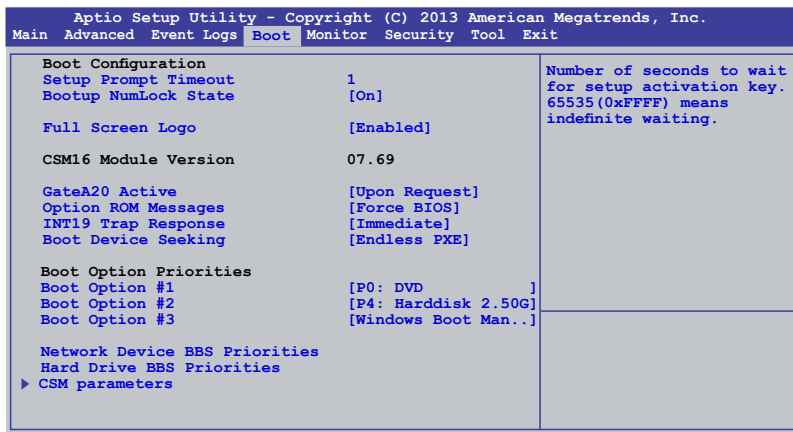

Setup Prompt Timeout [xx]

This item allows you to adjust the number of seconds to wait for setup activation key. Use the <+> and <-> keys to specify the values.

Bootup NumLock State [On]

Allows you to select the power-on state for the NumLock. Configuration options: [Off] [On]

Full Screen Logo [Enabled]

Allows you to enable or disable the full screen logo display feature. Configuration options: [Disabled] [Enabled].



Set the **Full Screen Logo** to [Enabled] to use the ASUS MyLogo2™ feature.

GateA20 Active [Upon Request]

This item is useful when any RT code is execute above 1MB. When set to [Upon Request], the GA20 can be disabled using BIOS services. When set to [Always], disabling of GA20 is not allowed. Configuration options: [Upon Request] [Always].

Option ROM Messages [Force BIOS]

Allows you to set the display mode for Option ROM. Configuration options: [Force BIOS] [Keep Current]

INT19 Trap Response [Immediate]

This item allows you to set the BIOS reaction on INT19 trapping by Option ROM.
Configuration options: [Immediate] [Postponed]

Boot Device Seeking [Endless PXE]

This allows you to enable the Boot Device Seeking option. Configuration options:
[Endless PXE] Continuously seek remote boot image until boot image is found or the operation is aborted <Ctrl>+<Alt>+ is pressed by the user).

[Normal] Seek remote boot image once then stop.

Boot Option Priorities

These items specify the boot device priority sequence from the available devices. The number of device items that appears on the screen depends on the number of devices installed in the system.



-
- To select the boot device during system startup, press <F8> when ASUS Logo appears.
 - To access Windows® OS in Safe Mode, do any of the following:
 - Press <F5> when ASUS Logo appears.
 - Press <F8> after POST.
-

Network Device BBS Priorities / Hard Drive BBS Priorities

This allows you to set the order of the legacy devices in this group.

CSM Parameters

This allows you to set OpROM execution, boot options filter, and other OpROM settings settings.

Aptio Setup Utility - Copyright (C) 2013 American Megatrends, Inc.		
Boot		
Launch CSM	[Enabled]	This option controls if CSM will be launched.
Boot Option filter	[Legacy only]	
Launch PXE OpROM policy	[Legacy only]	
Launch Storage OpRom policy	[Legacy only]	
Launch Video OpRom policy	[Legacy only]	
Other PCI device ROM priority	[Legacy OpROM]	

Launch CSM [Enabled]

This option allows you to enable or disable the launch of CSM. Configuration options: [Disabled] [Enabled]

Boot Option filter [Legacy only]

This option allows you to control what devices the system can boot to. Configuration options: [UEFI and Legacy] [Legacy only] [UEFI only]

Launch PXE OpROM policy [Legacy only]

This option allows you to control the execution of UEFI and Legacy PXE OpROM. Configuration options: [Do not launch] [UEFI only] [Legacy only] [Legacy first] [UEFI first]

Launch Storage OpROM policy [Legacy only]

This option allows you to control the execution of UEFI and Legacy Storage OpROM. Configuration options: [Do not launch] [UEFI only] [Legacy only] [Legacy first] [UEFI first]

Launch Video OpROM policy [Legacy only]

This option allows you to control the execution of UEFI and Legacy Storage OpROM. Configuration options: [Do not launch] [UEFI only] [Legacy only] [Legacy first] [UEFI first]

Other PCI device ROM priority [Legacy OpROM]

This option allows you to control the execution of UEFI and Legacy Storage OpROM. Configuration options: [UEFI OpROM] [Legacy OpROM]

4.7 Monitor menu

The Monitor menu displays the system temperature/power status, and allows you to change the fan settings.

Aptio Setup Utility - Copyright (C) 2013 American Megatrends, Inc.							
Main	Advanced	Event Logs	Boot	Monitor	Security	Tool	Exit
CPU Temperature	:	+58°C/	+162°F	Whisper/Generic/High/			
MB Temperature	:	+52°C/	+151°F	Speed/Full Speed			
TR1 Temperature	:	N/A					
CPU_FAN1 Speed	:	1054 RPM					
REAR_FAN1 Speed	:	N/A					
FRNT_FAN1 Speed	:	N/A					
FRNT_FAN2 Speed	:	N/A					
FRNT_FAN3 Speed	:	N/A					
VCORE1	:	+1.800 V					
+12V	:	+12.288 V					
+5V	:	+5.040 V					
+VDDQ	:	+1.504 V					
+3VSB	:	+3.408 V					
+3.3V	:	+1.296 V					
VBAT	:	+3.344 V					
FAN Speed Control		[Generic Mode]					

CPU/MB/TR1 Temperature [xxx°C/xxx°F]

The onboard hardware monitor automatically detects and displays the CPU and motherboard component temperatures.

CPU_FAN1 Speed; FRNT_FAN1-3 Speed; REAR_FAN1 Speed [xxxx RPM] or [Ignore] / [N/A]

The onboard hardware monitor automatically detects and displays the speed of CPU fans, front fans, and rear fan in rotations per minute (RPM). If the fan is not connected to the motherboard, the field shows **N/A**.

VCORE1 Voltage: +12V, +5V, +VDDQ, +3VSB, +3.3V, and VBAT

The onboard hardware monitor automatically detects the voltage output through the onboard voltage regulators.

Fan Speed Control [Generic Mode]

Allows you to configure the ASUS Smart Fan feature that smartly adjusts the fan speeds for more efficient system operation. Configuration options:

[Low Speed Mode] [Generic Mode] [High Speed Mode] [Full Speed Mode]

4.8 Security

This menu allows a new password to be created or a current password to be changed. The menu also enables or disables the Secure Boot state and lets the user configure the System Mode state.

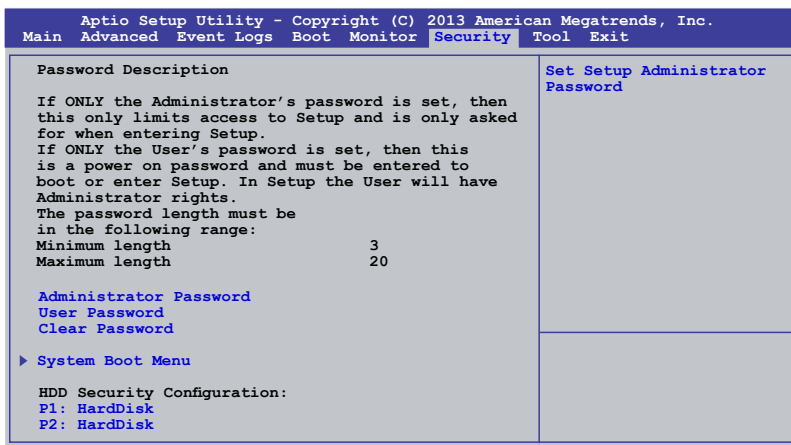

Administrator Password

To set an administrator password:

1. Select the Administrator Password item and press <Enter>.
2. From the Create New Password box, key in a password, then press <Enter>.
3. Confirm the password when prompted.

To change an administrator password:

1. Select the Administrator Password item and press <Enter>.
2. From the Enter Current Password box, key in the current password, then press <Enter>.
3. From the Create New Password box, key in a new password, then press <Enter>.
4. Confirm the password when prompted.



To clear the administrator password, follow the same steps as in changing an administrator password, but press <Enter> when prompted to create/confirm the password.

User Password

To set a user password:

1. Select the User Password item and press <Enter>.
2. From the Create New Password box, key in a password, then press <Enter>.
3. Confirm the password when prompted.

To change a user password:

1. Select the User Password item and press <Enter>.
2. From the Enter Current Password box, key in the current password, then press <Enter>.
3. From the Create New Password box, key in a new password, then press <Enter>.
4. Confirm the password when prompted.

To clear a user password:

1. Select the Clear User Password item and press <Enter>.
2. Select **Yes** from the Warning message window then press <Enter>.

Secure Boot Menu

This item allows you to customize the Secure Boot settings.

Aptio Setup Utility - Copyright (C) 2013 American Megatrends, Inc.		
Security		
Platform Mode	Setup	Secure Boot flow control. Secure Boot can be enabled only when Platform Key (PK) is enrolled and Platform is operating in User mode.
Secure Boot	Disabled	
Secure Boot Control	[Enabled]	
Secure Boot Mode	[Standard]	
▶ Image Execution Policy		
▶ Key Management		

Secure Boot Control [Enabled]

This item allows you to enable or disable the Secure Boot flow control.

Configuration options: [Disabled] [Enabled]

Secure Boot Mode [Standard]

This item allows you to select the mode of the Secure boot to change Execution policy and Secure Boot Key management. Configuration options: [Standard] [Custom]

Image Execution Policy

This item only appears when you set the Secure Boot Mode to [Custom]. This allows you to manage the Image Policy on Security Violation.

Aptio Setup Utility - Copyright (C) 2013 American Megatrends, Inc.		
Security		
Interval FV Option ROM Removable Media Fixed Media	[Always Execute] [Deny Execute] [Deny Execute] [Deny Execute]	Image Execution Policy per device path on Security Violation.

Internal FV [Always Execute]

Configuration options: [Always Execute]

Option ROM/Removable Media/Fixed Media [Deny Execute]

Configuration options: [Always Execute] [Always Deny] [Allow Execute] [Defer Execute] [Deny Execute] [Query User]

Key Management

This item only appears when you set the Secure Boot Mode to [Custom]. This allows you to modify Secure Boot variables and set Key Management page.

Aptio Setup Utility - Copyright (C) 2013 American Megatrends, Inc.		
Security		
Factory Default Key Provisioning [Disabled]		Install Factory default Secure Boot Keys when System is in Setup Mode
▶ Install All Factory Default Keys		
Platform Key (PK)	NOT INSTALLED	
▶ Set new PK		
▶ Delete PK		
Key Exchange Key Database (KEK)	NOT INSTALLED	
▶ Set new KEK		
▶ Delete KEK		
▶ Append Var to KEK		
Authorized Signature Database (DB)	NOT INSTALLED	
▶ Set new DB		
▶ Delete DB		
▶ Append Var to DB		
Forbidden Signature Database (DBX)	NOT INSTALLED	
▶ Set new DBX		
▶ Delete DBX		
▶ Append Var to DBX		

Factory Default Key Provisioning [Disabled]

Configuration options: [Disabled] [Enabled]

Install All Factory Default Keys

This item will ask you if you want to Install Factory Default secure variables. Select Yes if you want to load the default secure variables, otherwise select No.

Platform Key (PK)/Key Exchange Key Database (KEK)/Authorized Signature Database (DB)/ Forbidden Signature Database (DBX)

Configuration options: [Set New] [Delete] [Append]

4.9 Tool menu

The Tool menu items allow you to configure options for special functions. Select an item then press <Enter> to display the submenu.

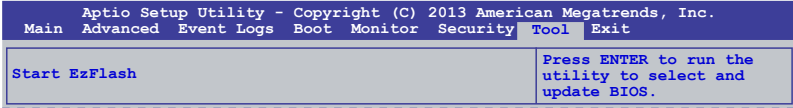

Start EzFlash utility

Allows you to run the Start EzFlash utility. For more information, see section 4.1.2 ASUS EzFlash utility.

4.10 Exit menu

The Exit menu items allow you to save or discard your changes to the BIOS items.

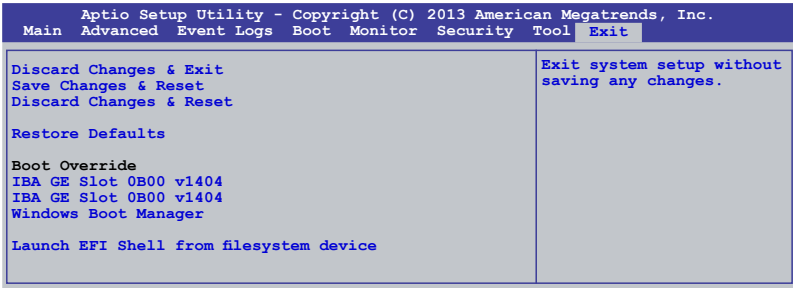

Pressing <Esc> does not immediately exit this menu. Select one of the options from this menu or <F10> from the legend bar to exit.

Discard Changes & Exit

This option allows you to exit the Setup program without saving your changes. When you select this option or if you press <Esc>, a confirmation window appears. Select **Yes** to discard changes and exit.

Save Changes & Reset

Once you are finished making your selections, choose this option from the Exit menu to ensure the values you selected are saved. When you select this option or if you press <F10>, a confirmation window appears. Select **Yes** to save changes and exit.

Discard Changes & Reset

This option allows you to reset without saving your changes. When you select this option or if you press <ENTER>, a confirmation window appears. Select Yes to discard changes and reset.

Restore Defaults

This option allows you restore or load the default values for all the setup options. When you select this option or if you press <ENTER>, a confirmation window appears. Select **Yes** to apply the default values or press <Esc> to exit.

Launch EFI Shell from filesystem device

This option allows you to launch the EFI Shell application (shellx64.efi) from one of the available filesystem devices. Select Yes to proceed, or No to cancel, and then press <Enter>.

Chapter 5: RAID Configuration

5

Chapter summary

This chapter provides instructions for setting up, creating, and configuring RAID sets using the available utilities.

This chapter contains the following sections:

5.1	Setting up RAID.....	5-3
5.2	Intel® Rapid Storage Technology enterprise SATA Option ROM Utility	5-5
5.3	Intel® Rapid Storage Technology enterprise (Windows)	5-13

5.1 Setting up RAID

The motherboard comes with the Intel® C224 controller that supports Intel® Rapid Storage Technology enterprise Option ROM Utility with RAID 0, RAID 1, RAID 10, and RAID 5 support (for Windows® OS only).

5.1.1 RAID definitions

RAID 0 (Data striping) optimizes two identical hard disk drives to read and write data in parallel, interleaved stacks. Two hard disks perform the same work as a single drive but at a sustained data transfer rate, double that of a single disk alone, thus improving data access and storage. Use of two new identical hard disk drives is required for this setup.

RAID 1 (Data mirroring) copies and maintains an identical image of data from one drive to a second drive. If one drive fails, the disk array management software directs all applications to the surviving drive as it contains a complete copy of the data in the other drive. This RAID configuration provides data protection and increases fault tolerance to the entire system. Use two new drives or use an existing drive and a new drive for this setup. The new drive must be of the same size or larger than the existing drive.

RAID 10 is data striping and data mirroring combined without parity (redundancy data) having to be calculated and written. With the RAID 10 configuration you get all the benefits of both RAID 0 and RAID 1 configurations. Use four new hard disk drives or use an existing drive and three new drives for this setup.

RAID 5 stripes both data and parity information across three or more hard disk drives. Among the advantages of RAID 5 configuration include better HDD performance, fault tolerance, and higher storage capacity. The RAID 5 configuration is best suited for transaction processing, relational database applications, enterprise resource planning, and other business systems. Use a minimum of three identical hard disk drives for this setup.



If you want to boot the system from a hard disk drive included in a created RAID set, copy first the RAID driver from the support DVD to a floppy disk before you install an operating system to the selected hard disk drive.

5.1.2 Installing hard disk drives

The motherboard supports Serial ATA for RAID set configuration. For optimal performance, install identical drives of the same model and capacity when creating a disk array.

To install the SATA hard disks for RAID configuration:

1. Install the SATA hard disks into the drive bays following the instructions in the system user guide.
2. Connect a SATA signal cable to the signal connector at the back of each drive and to the SATA connector on the motherboard.
3. Connect a SATA power cable to the power connector on each drive.

5.1.3 Setting Jumpers



Ensure to turn off power before setting the jumpers on the motherboard.

You must set the jumper settings of your motherboard to activate the embedded **Intel® Rapid Storage Technology enterprise SATA Option ROM Utility**.

To set the jumper settings for **Intel® Rapid Storage Technology enterprise SATA Option ROM Utility**, set the 3-pin RAID_SEL1 jumper to pins 2-3.

For more information about the jumper settings of 3-pin RAID_SEL1, you may refer to the **RAID configuration utility** section on page 2-27.

5.1.4 Setting the RAID mode in BIOS

You must set the RAID mode in the BIOS Setup to be able to launch the RAID utilities before you can create a RAID set from the SATA hard disk drives attached to the SATA connectors supported by Intel® C224 chipset.

To do this:

1. Enter the BIOS Setup during POST.
2. Go to the **Advanced Menu > SATA Configuration**, then press <Enter>.
3. Set **SATA Mode** to [RAID].
4. Press <F10> to save your changes and exit the BIOS Setup.



Refer to **Chapter 4** for details on entering and navigating through the BIOS Setup.

5.1.5 RAID configuration utilities

Depending on the RAID connectors that you use, you can create a RAID set using the utilities embedded in each RAID controller. For example, use the **Intel® Rapid Storage Technology enterprise SATA Option ROM Utility** if you installed Serial ATA hard disk drives on the Serial ATA connectors supported by the Intel® C224 chipset.

5.2 Intel® Rapid Storage Technology enterprise SATA Option ROM Utility

The Intel® Rapid Storage Technology enterprise SATA Option ROM utility allows you to create RAID 0, RAID 1, RAID 10 (RAID 1+0), and RAID 5 set from Serial ATA hard disk drives that are connected to the Serial ATA connectors supported by the Southbridge.



Before you proceed, ensure that you have installed the Serial ATA hard disk drives, have set the correct jumper settings of the motherboard, and have set the correct SATA mode in the BIOS setup. You can refer to sections **5.1.2 Installing hard disk drives**, **5.1.3 Setting Jumpers**, and **5.1.4 Setting the RAID mode in BIOS** for more information.

To launch the Intel® Rapid Storage Technology enterprise SATA Option ROM utility:

1. Turn on the system.
2. During POST, press <Ctrl>+<I> to display the utility main menu.

```
Intel(R) Rapid Storage Technology enterprise - SATA Option ROM - 3.6.0.1023
Copyright(C) 2003-12 Intel Corporation. All Rights Reserved.

[ MAIN MENU ]
1. Create RAID Volume
2. Delete RAID Volume
3. Reset Disks to Non-RAID
4. Exit

[ DISK/VOLUME INFORMATION ]

RAID Volumes:
None defined.

Physical Disks:
ID Drive Model Serial # Size Type/Status (Vol ID)
0 ST3300656SS HWAS0000991753TR 279.3GB Non-RAID Disk
1 ST3300656SS 37VN00009846RAJ1 279.3GB Non-RAID Disk
2 ST3300656SS 397600009846UEDY 279.3GB Non-RAID Disk
3 ST3300656SS GWC50000991756G6 279.3GB Non-RAID Disk

[↑,↓]-Select [ESC]-Exit [ENTER]-Select Menu
```

The navigation keys at the bottom of the screen allow you to move through the menus and select the menu options.



The RAID BIOS setup screens shown in this section are for reference only and may not exactly match the items on your screen.

5.2.1 Creating a RAID set

To create a RAID set:

1. From the utility main menu, select **1. Create RAID Volume** and press <Enter>.
2. Key in a name for the RAID set and press <Enter>.



3. Press the up/down arrow keys to select a RAID Level that you wish to create then press <Enter>.
4. From the **Disks** item field, press <Enter> to select the hard disk drives that you want to include in the RAID set.

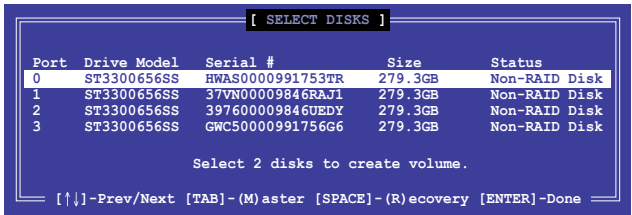

5. Use the up/down arrow keys to move the selection bar then press <Space> to select a disk. A small triangle before the Port number marks the selected drive. Press <Enter> when you are done.

6. Use the up/down arrow keys to select the stripe size for the RAID array (for RAID 0, 10 and 5 only) then press <Enter>. The available stripe size values range from 4 KB to 128 KB. The following are typical values:
RAID 0: 128KB
RAID 10: 64KB
RAID 5: 64KB



We recommend a lower stripe size for server systems, and a higher stripe size for multimedia computer systems used mainly for audio and video editing.

7. In the **Capacity** field item, key in the RAID volume capacity that you want to use and press <Enter>. The default value field indicates the maximum allowed capacity.
8. Press <Enter> to start creating the RAID volume.
9. From the following warning message, press <Y> to create the RAID volume and return to the main menu, or press <N> to go back to the **CREATE VOLUME** menu.



5.2.2 Deleting a RAID set



Take caution when deleting a RAID set. You will lose all data on the hard disk drives when you delete a RAID set.

To delete a RAID set:

1. From the utility main menu, select **2. Delete RAID Volume** and press <Enter>.
2. From the Delete Volume Menu, press the up/down arrow keys to select the RAID set you want to delete then press .

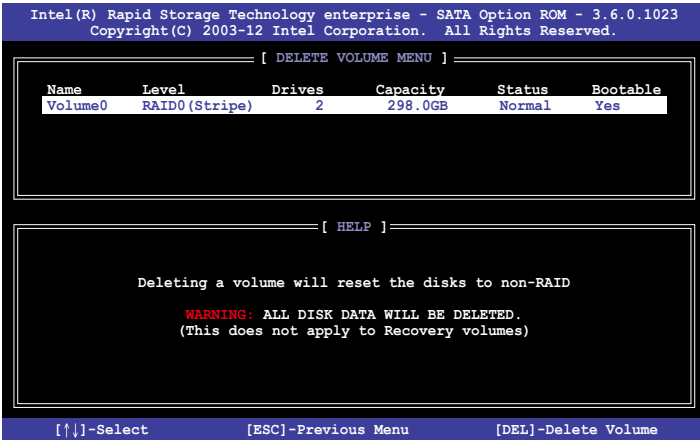

3. Press <Y> to confirm deletion of the selected RAID set and return to the utility main menu, or press <N> to return to the **DELETE VOLUME** menu.

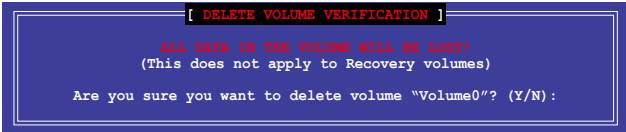

5.2.3 Resetting disks to Non-RAID



Take caution before you reset a RAID volume hard disk drive to non-RAID. Resetting a RAID volume hard disk drive deletes all internal RAID structure on the drive.

To reset a RAID set:

1. From the utility main menu, select **3. Reset Disks to Non-RAID** and press <Enter>.
2. Press the up/down arrow keys to select the drive(s) or disks of the RAID set you want to reset, then press <Space>. A small triangle before the Port number marks the selected drive. Press <Enter> when you are done.

```
[ RESET RAID DATA ]
Resetting RAID disk will remove its RAID structures
and revert it to a non-RAID disk.

WARNING: Resetting a disk causes all data on the disk to be lost.
(This does not apply to Recovery volumes)

Port  Drive Model  Serial #          Size    Status
---  -
0     ST3300656SS    HWAS0000991753TR 279.3GB Member Disk
1     ST3300656SS    37VN00009846RAJ1 279.3GB Member Disk

Select the disks that should be reset.

[↑↓]-Previous/Next [SPACE]-Selects [ENTER]-Selection Complete
```

3. Press <Y> in the confirmation window to reset the drive(s) or press <N> to return to the utility main menu.

5.2.4 Exiting the Intel® Rapid Storage Technology enterprise SATA Option ROM utility

To exit the utility:

1. From the utility main menu, select **4. Exit** then press <Enter>.
2. Press <Y> to exit or press <N> to return to the utility main menu.



5.2.5 Rebuilding the RAID



This option is only for the RAID 1 set.

Rebuilding the RAID with other non-RAID disk

If any of the SATA hard disk drives included in the RAID 1 array failed, the system displays the status of the RAID volume as **"Degraded"** during POST. You can rebuild the RAID array with other installed non-RAID disks.

To rebuild the RAID with other non-RAID disk:

1. During POST, press <Ctrl>+<I> at the prompt to enter the Intel Rapid Storage Technology option ROM utility.
2. If there is a non-RAID SATA Hard Disk available, the utility will prompt you to rebuild the RAID. Press the up/down arrow keys to select the destination disk then Press <Enter> to start the rebuilding process, or press <ESC> to exit.

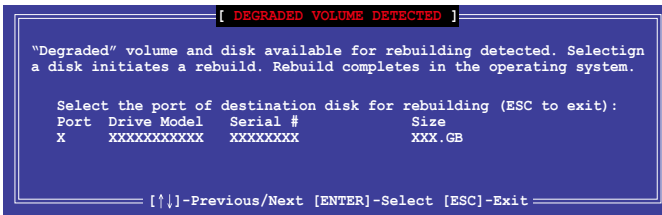

Select a destination disk with the same size as the original hard disk.

- The utility immediately starts rebuilding after the disk is selected. When done, the status of the degraded RAID volume is changed to **"Rebuild"**.

```

Intel(R) Rapid Storage Technology enterprise - SATA Option ROM - 3.6.0.1023
Copyright(C) 2003-12 Intel Corporation. All Rights Reserved.

[ MAIN MENU ]
1. Create RAID Volume
2. Delete RAID Volume
3. Reset Disks to Non-RAID
4. Exit

[ DISK/VOLUME INFORMATION ]

RAID Volumes:
ID Name Levell Strip Size Status Bootable
1 Volume0 RAID1 (Mirror) N/A 149.0GB Rebuild Yes

Physical Devices:
Port Drive Model Serial # Size Type/Status (Vol ID)
1 S73160812AS 9LS0F4HL 149.0GB Member Disk (0)
2 S73160812AS 3LS0JYL8 149.0GB Member Disk (0)

Volumes with "Rebuild" status will be rebuilt within the operating system.

[↑↓]-Select [ESC]-Exit [ENTER]-Select Menu

```

- Press <Esc> to exit Intel Rapid Storage Technology and reboot the system.
- Select **Start > Programs > Intel Rapid Storage > Intel Rapid Storage Console** or click the **Intel Rapid Storage Technology** tray icon to load the Intel Rapid Storage Manager utility.
- From the **View** menu, select **Advanced Mode** to display the details of the Intel Rapid Storage Console.
- From the **Volumes view** option, select **RAID volume** to view the rebuilding status. When finished, the status is changed to **"Normal"**.

Rebuilding the RAID with a new hard disk

If any of the SATA hard disk drives included in the RAID array failed, the system displays the status of the RAID volume as **"Degraded"** during POST. You may replace the disk drive and rebuild the RAID array.

To rebuild the RAID with a new hard disk:

- Remove the failed SATA hard disk and install a new SATA hard disk of the same specification into the same SATA Port.



Select a destination disk with the same size as the original hard disk.

- Reboot the system then follow the steps in section **Rebuilding the RAID with other non-RAID disk**.

5.2.6 Setting the Boot array in the BIOS Setup Utility

You can set the boot priority sequence in the BIOS for your RAID arrays when creating multi-RAID using the Intel® Rapid Storage Technology enterprise SATA Option ROM utility.

To set the boot array in the BIOS:



Set at least one of the arrays bootable to boot from the hard disk.

1. Reboot the system and press to enter the BIOS setup utility during POST.
2. Go to the **Boot** menu and select the boot option priority.
3. Use up/down arrow keys to select the boot priority and press <Enter>. See the **Boot menu** section of Chapter 4 for more details.
4. From the **Exit** menu, select **Save Changes & Exit**, then press <Enter>.
5. When the confirmation window appears, select **Yes**, then press <Enter>.

5.3 Intel® Rapid Storage Technology enterprise (Windows)

The Intel® Rapid Storage Technology enterprise allows you to create RAID 0, RAID 1, RAID 10 (RAID 1+0), and RAID 5 set(s) from Serial ATA hard disk drives that are connected to the Serial ATA connectors supported by the Southbridge.



You need to manually install the Intel® Rapid Storage Technology enterprise utility on a Windows® operating system. Please refer to the installation instructions in Chapter 6.

To enter the Intel® Rapid Storage Technology enterprise utility under Windows operating system:

1. Turn on the system to windows desktop.
2. Click the **Intel® Rapid Storage Technology enterprise** icon to display the main menu.

Your storage system is configured for data protection, increased performance and optimal data storage capacity. You can create additional volumes to further optimize your storage system.

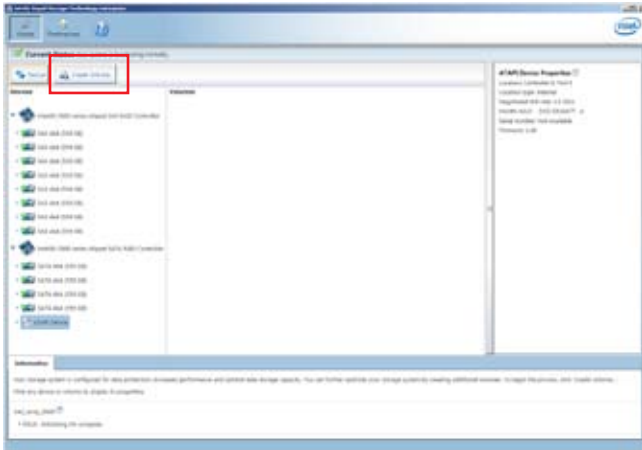

You can click **Rescan** to re-scan any attached hard disks.

5.3.1 Creating a RAID set

To create a RAID set:

1. From the utility main menu, select **Create Volume** then select volume type and click **Next**.

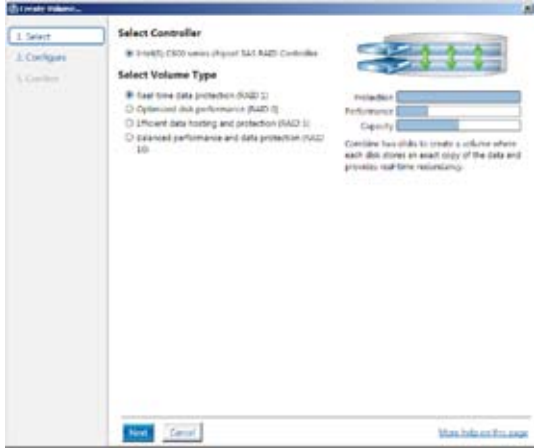

2. Key in a name for the RAID set, then select the array disks.
3. Select the **Volume Size** tab then drag the bar to set the volume size.
5. Click **Next**.

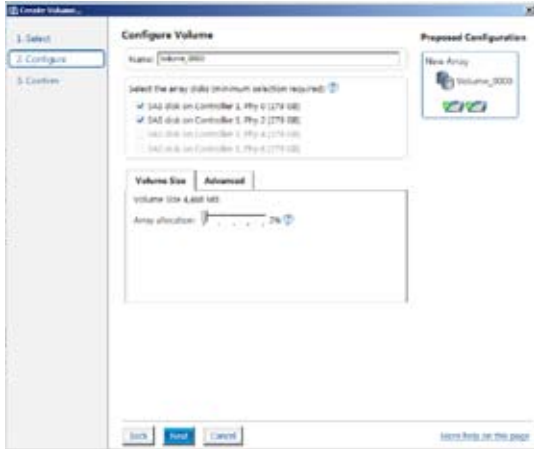

- If you do not want to keep the data on one of the selected disks, select **NO** when prompted.
- If you want to **Enable volume write-back cache** or **Initialize volume**, click **Advanced**.

5. Confirm the volume creation, then click **Create Volume** to continue.



This process could take a while depending on the number and size of the disks. You can continue using other applications during this time.

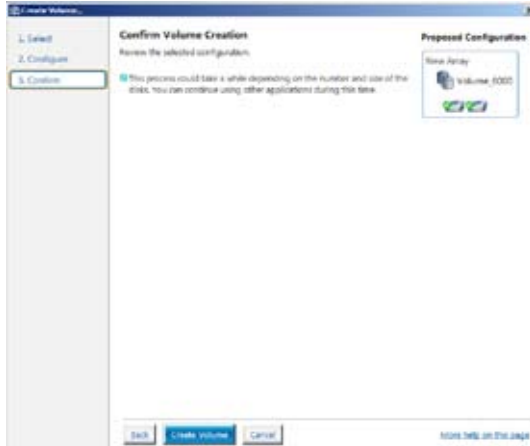

6. Wait until the process is completed, then click **OK** when prompted.



You still need to partition your new volume using Windows Disk Management before adding any data.

The created RAID set is displayed in the **Volumes** list. If you wish to change the settings, go to **Volume Properties**.

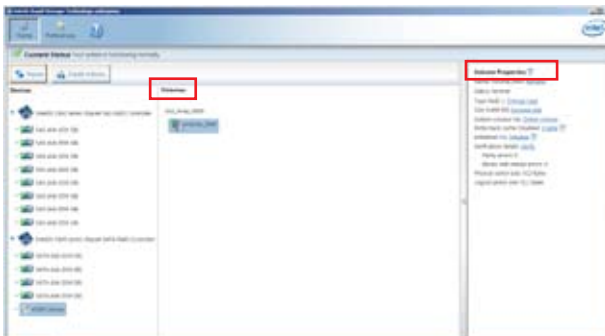

5.3.2 Changing a Volume Type

To change the volume type in **Volume Properties**:

1. Click the SATA array items you want to change in **Volumes** field.
2. From the **Volume Properties** field, select **Type:RAID 1 Change type**.

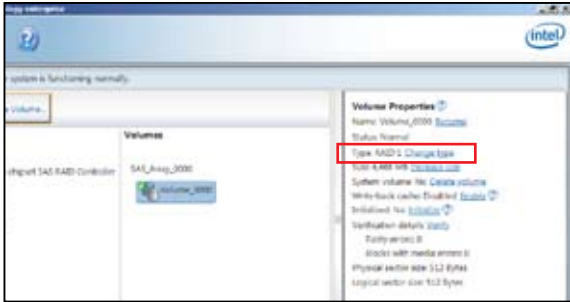

3. You can also change the **Name**, **Select the new volume type**, and **Select additional disks to include in the new volume** if needed.
4. Select the **Data stripe size** for the RAID array (for RAID 0, 10 and 5 only) and click **OK**. The available stripe size values range from 4 KB to 128 KB. The following are typical values:
RAID 0: 128KB
RAID 10: 64KB
RAID 5: 64KB

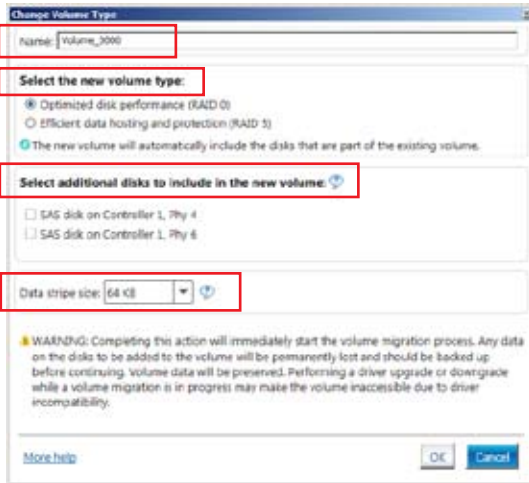

We recommend a lower stripe size for server systems, and a higher stripe size for multimedia computer systems used mainly for audio and video editing.

5.3.3 Deleting a volume



Be cautious when deleting a volume. You will lose all data on the hard disk drives. Before you proceed, ensure that you back up all your important data from your hard drives.

To delete a volume:

1. From the **Volumes** field in the utility main menu, select the volume that you want to delete.

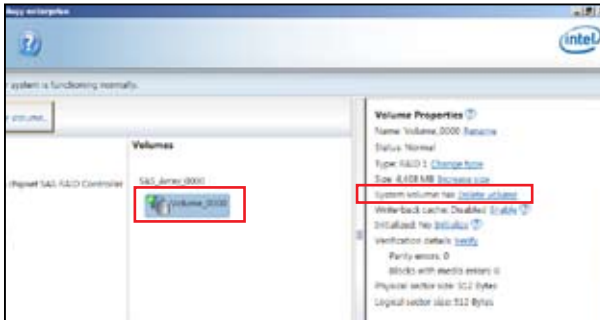

2. From the **Volume Properties** field, select **Delete volume**.
3. Click **Yes** to delete the volume and return to the utility main menu, or click **No** to return to the main menu.



5.3.4 Preferences

System Preferences

Allow you to set to show the notification area icon and show system information, warning, or errors here.

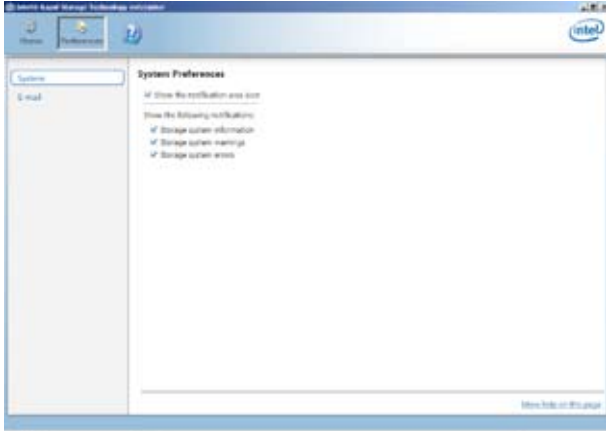

E-Mail Preferences

Allow you to set to sent e-mail of the following events:

- Storage system information
- Storage system warnings
- Storage system errors

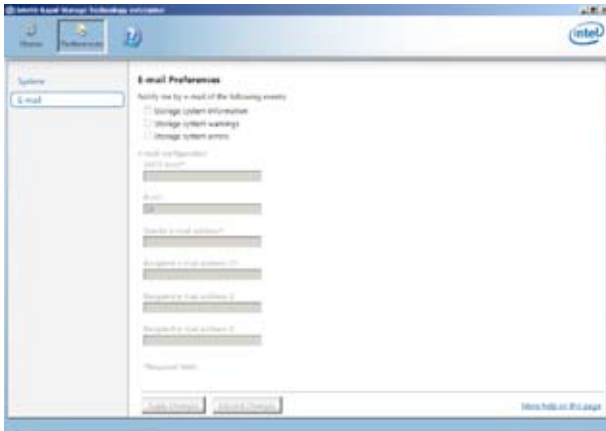

Chapter 6: Driver installation

6

Chapter summary

This chapter provides the instructions for installing the necessary drivers for different system components in both Linux® and Windows® Operating Systems.

This chapter contains the following sections:

6.1	RAID driver installation	6-3
6.2	Management applications and utilities installation	6-8
6.3	Running the Support DVD	6-8
6.4	Installing the LAN driver.....	6-16
6.5	Installing the VGA driver	6-21
6.6	Installing the Intel® C22x MEI NULL HECI driver	6-24
6.7	Installing the Intel® I210 Gigabit Adapter driver	6-26

6.1 RAID driver installation

After creating the RAID sets for your server system, you are now ready to install an operating system to the independent hard disk drive or bootable array. This part provides the instructions on how to install the RAID controller drivers during OS installation.

6.1.1 Creating a RAID driver disk



The system does not include a floppy drive. You have to use a USB floppy drive when creating a SATA RAID driver disk.

A floppy disk with the RAID driver is required when installing Windows® or Red Hat® Enterprise operating system on a hard disk drive that is included in a RAID set. You can create a RAID driver disk in DOS (using the Makedisk application in the support DVD).

To create a RAID driver disk in DOS environment:

1. Place the motherboard support DVD in the optical drive.
2. Restart your computer.
3. Enter the BIOS Setup.
4. Select the optical drive as the first boot priority to boot from the support DVD. Save your changes.
5. Exit the BIOS Setup and restart your computer.

The following Makedisk menu appears.

6. Select the **C22x INTEL RAID Driver** and press <Enter> to go to the sub-menu.

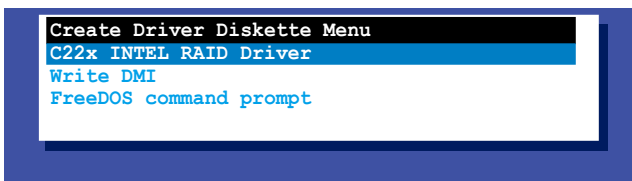

7. From the C22x Intel RAID Driver sub-menu, use the Up or Down arrow keys to select the driver and press <Enter> to create the RAID driver disk.

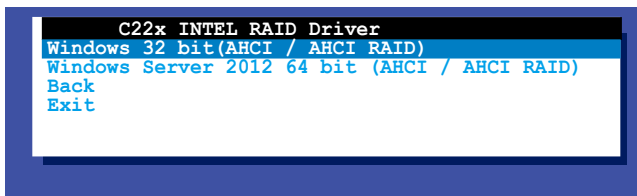

8. Select **YES** from the following warning message then press <Enter>.



9. On the following **Important** message, select **YES** if an ASMB7 is installed, otherwise select **NO**, then press <Enter>.



10. Insert the formatted diskette into the disk drive and press <Enter> to write the image to the disk.
11. Press any key to continue when prompted.

The Create Driver Diskette Menu appears after the creation of the diskette is finished.

To create a RAID driver disk in Windows® environment:

1. Start Windows®.
2. Place the motherboard support DVD into the optical drive.
3. Go to the **Make disk** menu, then select the type of RAID driver disk you want to create.
4. Insert a floppy disk into the USB floppy disk drive.
5. Follow succeeding screen instructions to complete the process.



Write-protect the floppy disk to avoid computer virus infection.

6.1.2 Installing the RAID controller driver

During Windows® Server 2008 OS installation

To install the RAID controller driver when installing Windows® Server 2008 OS

1. Boot the computer using the Windows® Server 2008 OS installation disc. Follow the screen instructions to start installing Windows Server 2008.
2. When prompted to choose a type of installation, click **Custom (advanced)**.

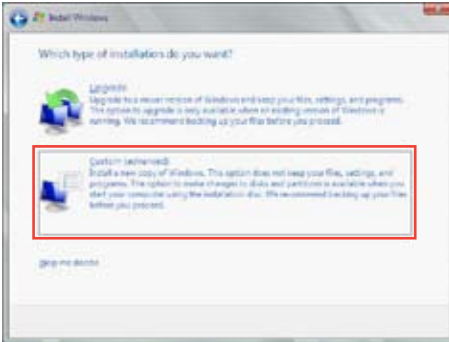

3. Click **Load Driver**.

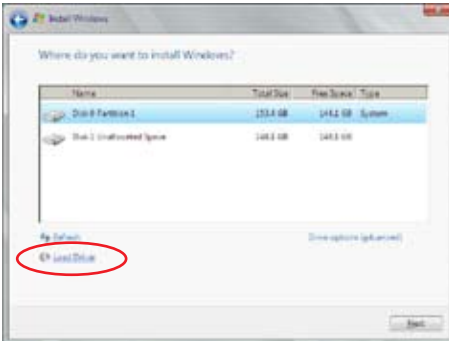

4. A message appears reminding you to insert the installation media containing the driver of the RAID controller driver. If you have only one optical drive installed in your system, eject the Windows OS installation disc and replace with the motherboard Support DVD into the optical drive. Click **Browse** to continue.



5. Locate the driver in the corresponding folder of the Support DVD, and then click **OK** to continue.
6. Select the RAID controller driver you need from the list and click **Next**.
7. When the system finishes loading the RAID driver, replace the motherboard Support DVD with the Windows Server installation disc. Select the drive to install Windows and click **Next**.

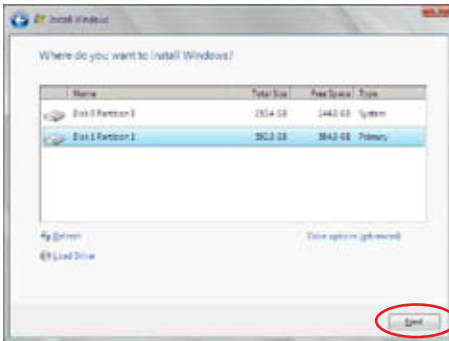

8. Follow succeeding screen instructions to continue.

6.2 Management applications and utilities installation

The support DVD that is bundled with your motherboard contains drivers, management applications, and utilities that you can install to maximize the features of your motherboard.



1. The contents of the support DVD are subject to change at any time without notice. Visit the ASUS website (www.asus.com) for the latest updates on software and utilities.
2. The support DVD is supported on Windows® Server 2008 R2 and Windows® Server 2012.

6.3 Running the Support DVD

When you place the support DVD into the optical drive, the DVD automatically displays the main screen if Autorun is enabled in your computer. By default, the Drivers tab is displayed.



If Autorun is NOT enabled in your computer, browse the contents of the support DVD to locate the file **ASSETUP.EXE** from the **BIN** folder. Double-click the **ASSETUP.EXE** to run the support DVD.

The main screen of the Support DVD contains the following tabs:

1. Drivers
2. Utilities
3. MakeDisk
4. Manual
5. Contact



The main screen of the Support DVD looks exactly the same on the Windows® Server 2008 R2 and on the Windows® Server 2012 Operating System (OS).

6.3.1 Drivers menu tab

The Drivers Menu shows the available device drivers if the system detects installed devices. Install the necessary drivers to activate the devices.



6.3.2 Utilities menu tab

The Utilities menu displays the software applications and utilities that the motherboard supports.



6.3.3 MakeDisk menu tab

The MakeDisk menu contains items to create the Intel RAID driver disks.



Press the arrow down button in the lower part of the menu to view more items.



6.3.4 Manual menu

The Manual menu provides the link to the Broadcom NetXtreme II Network Adapter user guide.



You need an internet browser installed in your OS to view the User Guide.



6.3.5 Contact information menu

The Contact menu displays the ASUS contact information, e-mail addresses, and useful links if you need more information or technical support for your motherboard.

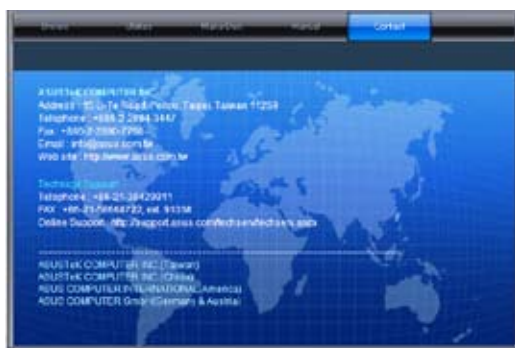

6.3.6 Installing the Intel® Chipset device Software driver

This section provides the instructions on how to install the Intel® chipset device software on the system.

You need to manually install the Intel® chipset device software on a Windows® Operating System.

To install the Intel® chipset device software on Windows® Server 2008 R2:

1. Restart the computer.
2. Log in with **Administrator** privileges.
3. Insert the Motherboard Support DVD to the optical drive.

The support DVD automatically displays the **Drivers** menu if Autorun is enabled in your computer.



If Autorun is NOT enabled in your computer, browse the contents of the support DVD to locate the file **ASSETUP.EXE** from the **BIN** folder. Double-click the **ASSETUP.EXE** to run the support DVD.

4. Click **Intel® Chipset Device Software** from the Drivers menu to start the installation.

- From the **Intel® Chipset Device Software**, click **Next** to start the installation.



- In the **License Agreement** window, click **Yes** to continue.



- Read the Readme File information and click **Next** to continue.



To install the Intel® Chipset device software on Windows® Server 2012:

1. Restart the computer.
2. Log in with **Administrator** privileges.
3. Insert the Motherboard Support DVD to the optical drive.

The support DVD automatically displays the **Drivers** menu if Autorun is enabled in your computer.



If Autorun is **NOT** enabled in your computer, browse the contents of the support DVD to locate the file **ASSETUP.EXE** from the **BIN** folder. Double-click the **ASSETUP.EXE** to run the support DVD.

4. Click **Intel® Chipset Device Software** from the Drivers menu to start the installation.
5. From the **Intel® Chipset Device Software, Software**, click **Next**.



6. In the **License Agreement** window, click **Next >** to continue the process.



7. Read the Readme File information and click **Next** to continue.



8. When done, click **Finish** to complete the installation.



6.4 Installing the LAN driver

This section provides the instructions on how to install the **Intel® Network Connections Software** drivers on the system.

You need to manually install the LAN controller driver on a Windows® operating system.

To install the **LAN** controller device on Windows® Server 2008 R2:

1. Restart the computer.
2. Log in with **Administrator** privileges.
3. Insert the Motherboard Support DVD to the optical drive.

The support DVD automatically displays the **Drivers** menu if Autorun is enabled in your computer.



If Autorun is NOT enabled in your computer, browse the contents of the support DVD to locate the file **ASSETUP.EXE** from the **BIN** folder. Double-click the **ASSETUP.EXE** to run the support DVD.

4. Click **Intel® Network Connections Software** on the **Drivers** menu to start the installation.



5. From the **Intel® Network Connections** window, click **Install Drivers and Software**.



- 6. Click **Next** in the **Welcome to the InstallShield Wizard for Intel(R) Network Connections**.



- 7. From the **License Agreement** window, select **I accept the terms in the license agreement** then click **Next**.



- 8. Select the drivers you want to install in the **Setup Options** window and click **Next**.



- 9. From the **Ready to Install the Program** window, click **Install**.



10. Click **Yes** when the **Microsoft Management Console** dialog box appears.



The **Microsoft Management Console** dialog box appears when the system detects open or running applications that needs to be closed. You have to terminate open or running applications specified in the dialog box to proceed with the installation.

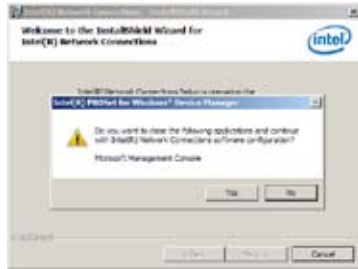

11. When done, click **Finish** to complete the installation.



To install the **LAN** controller device on Windows® Server 2012:

1. Restart the computer.
2. Log in with **Administrator** privileges.
3. Insert the Motherboard Support DVD to the optical drive.

The support DVD automatically displays the **Drivers** menu if Autorun is enabled in your computer.



If Autorun is **NOT** enabled in your computer, browse the contents of the support DVD to locate the file **ASSETUP.EXE** from the **BIN** folder. Double-click the **ASSETUP.EXE** to run the support DVD.

4. Click **Intel® Network Connections Software** on the **Drivers** menu to start the installation.

- 5. From the **Intel® Network Connections** window, click **Install Drivers and Software**.



- 6. Click Next in the **Welcome to the InstallShield Wizard for Intel(R) Network Connections** window.



- 7. Select the drivers you want to install in the **Setup Options** window and click **Next**.

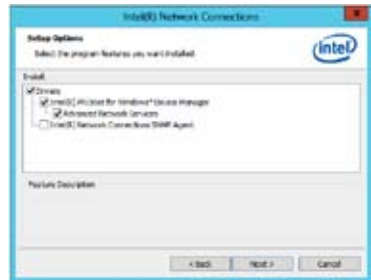

- Click **Install** to continue.

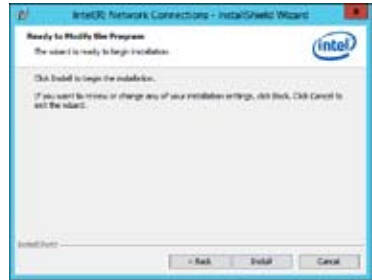

- When done, click **Finish** to complete the installation.

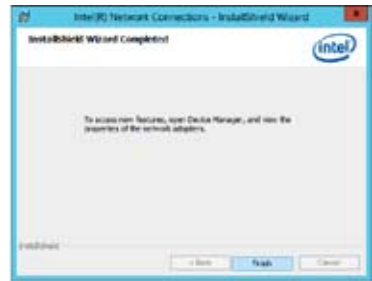

6.5 Installing the VGA driver

This section provides the instructions on how to install the **ASPEED Video Graphics Adapter (VGA)** driver.

To install the **ASPEED VGA** driver on Windows® Server 2008 R2:

1. Restart the computer.
2. Log in with **Administrator** privileges.
3. Insert the Motherboard Support DVD to the optical drive.

The support DVD automatically displays the **Drivers** menu if Autorun is enabled in your computer.



If Autorun is NOT enabled in your computer, browse the contents of the support DVD to locate the file **ASSETUP.EXE** from the **BIN** folder. Double-click the **ASSETUP.EXE** to run the support DVD.

4. From the **Main Menu**, click **ASPEED AST2300/AST1300 Display Driver** on the **Drivers** tab to start the installation.



5. From the **License Agreement** window, select **I accept the terms** and click **Next**.



6. Key in a username and organization then click **Next**.



7. Select **Complete** in the **Setup Type** window then click **Next**.



8. Click **Install** to begin the installation.



9. When done, click **Finish**.



- When prompted to restart the computer, click **Yes**.



To install the **ASPEED VGA** driver on Windows® Server 2012:

- Restart the computer.
- Log in with **Administrator** privileges.
- Insert the Motherboard Support DVD to the optical drive.

The support DVD automatically displays the **Drivers** menu if Autorun is enabled in your computer.



If Autorun is NOT enabled in your computer, browse the contents of the support DVD to locate the file **ASSETUP.EXE** from the **BIN** folder. Double-click the **ASSETUP.EXE** to run the support DVD.

- Click **ASPEED AST2300/AST1300 Display Driver** on the **Drivers** menu to start the installation.
- Click **OK** in the Driver Information window.



Wait for the loading of drivers to finish.

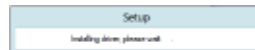

- Click **OK** to complete the installation.



6.6 Installing the Intel® C22x MEI NULL HECI driver

This section provides the instructions on how to install the Intel® C22x MEI NULL HECI driver on the motherboard.

To install the **Intel® C22x MEI NULL HECI** driver in Windows:

1. Restart the computer.
2. Log in with **Administrator** privileges.
3. Insert the motherboard/system support DVD to the optical drive.



If Autorun is NOT enabled in your computer, browse the contents of the support DVD to locate the file **ASSETUP.EXE** from the **BIN** folder. Double-click the **ASSETUP.EXE** to run the support DVD.

4. Click **Intel® C22x MEI NULL HECI** on the **Drivers** menu of the main screen to start the installation.



5. From the **Welcome to the Setup Program** window, click **Next**.



6. Click **Yes** in the **License Agreement** window to continue with the installation.



- 9. Click **NEXT** when the installation of driver is complete.



- 10. Click **Finish** to complete the installation.



6.7 Installing the Intel® I210 Gigabit Adapter driver

This section provides the instructions on how to install the **Intel® I210 Gigabit Adapter** driver on the system.

To install the **Intel® I210 Gigabit Adapter** driver on Windows® Server 2008 R2:

1. Restart the computer.
2. Log on with **Administrator** privileges.
3. Insert the motherboard/system support DVD to the optical drive.



If Autorun is NOT enabled in your computer, browse the contents of the support DVD to locate the file **ASSETUP.EXE** from the **BIN** folder. Double-click the **ASSETUP.EXE** to run the support DVD.

4. Click **Intel® I210 Gigabit Adapter Driver** in the **Drivers** menu of the main screen to start the installation.



5. Click **Next** to continue.



6. From the **Program Maintenance** window, select **Modify** then click **Next**.



7. Select the options you want to install then click **Next** to continue.

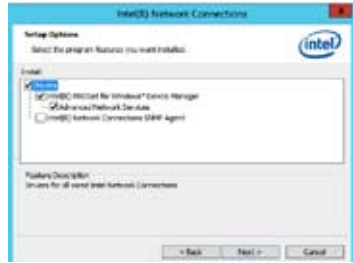

8. Click **Install** in the **Ready to Modify the Program** window to begin with the loading of the selected options.

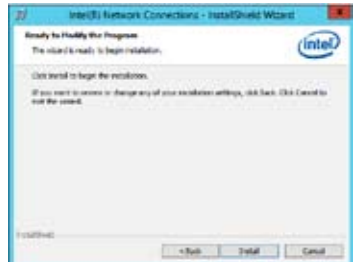

9. When done, click **Finish**.

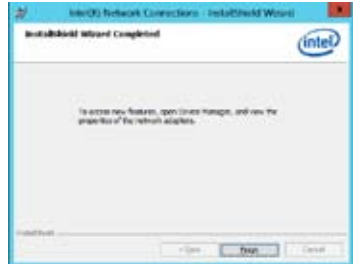

To install the **Intel® I210 Gigabit Adapter** driver on Windows® Server 2012:

1. Restart the computer.
2. Log on with **Administrator** privileges.
3. Insert the motherboard/system support DVD to the optical drive.



If Autorun is NOT enabled in your computer, browse the contents of the support DVD to locate the file **ASSETUP.EXE** from the **BIN** folder. Double-click the **ASSETUP.EXE** to run the support DVD.

4. Click **Intel® I210 Gigabit Adapter Driver** in the **Drivers** menu of the main screen to start the installation.
5. Click **Next** to continue.



6. From the **Program Maintenance** window, select **Modify** then click **Next**.

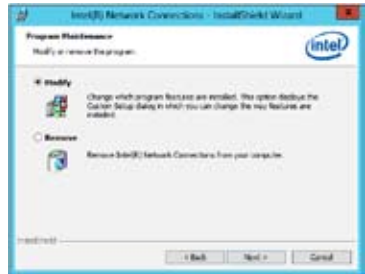

7. Select the options you want to install then click **Next** to continue.

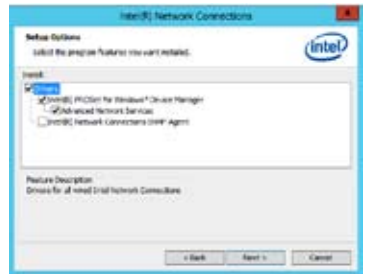

8. In the **Ready to Modify the Program** window, click **Install** to load the options you selected.

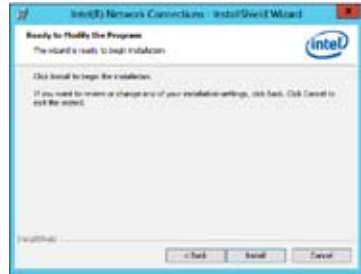

9. When done, click **Finish**.



Appendix A: Reference Information



Chapter summary

This appendix includes additional information that you may refer to when configuring the motherboard. This chapter contains the following sections:

A.1	P9D-E/4L block diagram	A-3
------------	-------------------------------------	------------

A.1 P9D-E/4L block diagram

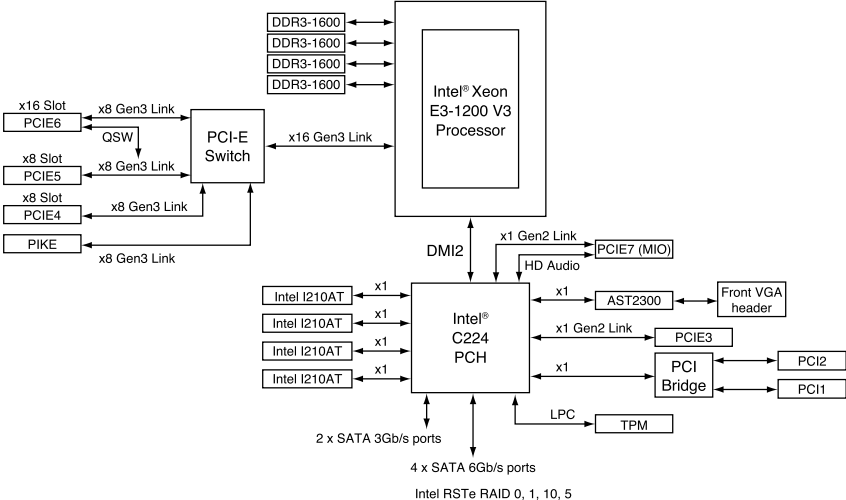

ASUS contact information

ASUSTeK COMPUTER INC.

Address 15 Li-Te Road, Peitou, Taipei, Taiwan 11259
Telephone +886-2-2894-3447
Fax +886-2-2890-7798
E-mail info@asus.com.tw
Web site <http://www.asus.com.tw>

Technical Support

Telephone +86-21-38429911
Fax +86-21-58668722 ext: 9101
Online Support <http://support.asus.com/techserv/techserv.aspx>

ASUSTeK COMPUTER INC. (Taiwan)

Address 15 Li-Te Road, Peitou, Taipei, Taiwan 11259
Telephone +886-2-2894-3447
Fax +886-2-2890-7798
E-mail info@asus.com.tw
Web site <http://www.asus.com.tw>

Technical Support

Telephone +886-2-2894-3447 (0800-093-456)
Online Support <http://support.asus.com/techserv/techserv.aspx>

ASUSTeK COMPUTER INC. (China)

Address No.508, Chundong Road, Xinzhuang Industrial Zone,
Minhang District, Shanghai, China.
Telephone +86-21-5442-1616
Fax +86-21-5442-0099
Web site <http://www.asus.com.cn>

Technical Support

Telephone +86-21-3407-4610 (800-820-6655)
Online Support <http://support.asus.com/techserv/techserv.aspx>

ASUS contact information

ASUS COMPUTER INTERNATIONAL (America)

Address 800 Corporate Way, Fremont, CA 94539, USA
Fax +1-510-608-4555
Web site <http://usa.asus.com>

Technical Support

Support fax +1-812-284-0883
General support +1-812-282-2787
Online support <http://support.asus.com/techserv/techserv.aspx>

ASUS COMPUTER GmbH (Germany and Austria)

Address Harkort Str. 21-23, D-40880 Ratingen, Germany
Fax +49-2102-959911
Web site <http://www.asus.de>
Online contact <http://www.asus.de/sales>

Technical Support

Telephone +49-1805-010923
Support Fax +49-2102-959911
Online support <http://support.asus.com/techserv/techserv.aspx>

ASUS Czech Service s.r.o. (Europe)

Address Na Rovince 887, 720 00 Ostrava – Hrabová, Czech Republic
Telephone +420-596766888
Web site <http://www.asus.cz>

Technical Support

Telephone +420-596-766-891
Fax +420-596-766-329
E-mail advance.rma.eu@asus.com
Online Support <http://support.asus.com/techserv/techserv.aspx>

ASUS contact information

ASUS Holland BV (The Netherlands)

Address Marconistraat 2, 7825GD EMMEN, The Netherlands
Web site <http://www.asus.com>

Technical Support

Telephone +31-(0)591-5-70292
Fax +31-(0)591-666853
E-mail advance.rma.eu@asus.com
Online Support <http://support.asus.com/techserv/techserv.aspx>

ASUS Polska Sp. z o.o. (Poland)

Address Ul. Postępu 6, 02-676 Warszawa, Poland
Web site <http://pl.asus.com>

Technical Support

Telephone +48-225718033
Online Support <http://support.asus.com/techserv/techserv.aspx>

ASK-Service (Russia and CIS)

Address г.Москва, ул. Орджоникидзе, д.10, Россия
Telephone (495) 640-32-75
Web site <http://ru.asus.com>

Technical Support

Telephone 008-800-100-ASUS (008-800-100-2787)
Online Support <http://vip.asus.com/eservice/techserv.aspx?SLanguage=ru>

DECLARATION OF CONFORMITY

Per FCC Part 2, Section 2.1077(a)



Responsible Party Name: **Asus Computer International**

Address: **800 Corporate Way, Fremont, CA 94539.**

Phone/Fax No: **(510)739-3777/(510)608-4555**

hereby declares that the product

Product Name : Motherboard

Model Number : P9D-E/4L, P9D-E/4L(ASMB7-IKVM)

Conforms to the following specifications:

- FCC Part 15, Subpart B, Unintentional Radiators

Supplementary Information:

This device complies with part 15 of the FCC Rules. Operation is subject to the following two conditions: (1) This device may not cause harmful interference, and (2) this device must accept any interference received, including interference that may cause undesired operation.

Representative Person's Name : Steve Chang/ President

Steve Chang

Signature : _____
Date : Apr. 12, 2013

Ver. 120001

EC Declaration of Conformity



We, the undersigned,

Manufacturer: **ASUS&C COMPUTER INC**
Manufacturer's City: **4F, No. 150, LITE Rd., PEITOU, TAIPEI 112, TAIWAN**
Country: **TAIWAN**
Authorized representative in Europe: **ASUS COMPUTER GmbH**
Address, City: **HARKORT STR. 21-23, 40880 RATINGEN**
Country: **GERMANY**

declare the following apparatus:

Product name : **Motherboard**
Model name : **P9D-E/4L, P9D-E/4L(ASMB7-IKVM)**

conform with the essential requirements of the following directives:

§2004/108/EC-EMC Directive

- EN 55022:2010
- EN 55024:2010
- EN 60950-3:2006
- EN 55035:2007/11/2011
- EN 55032:2005
- 1989/CEC-R&TTE Directive**
- EN 300 328 V1.7 (12/06-10)
- EN 300 440-1 V1.6 (12/01-06)
- EN 300 440-2 V1.6 (12/01-06)
- EN 300 440-3 V1.4 (12/02-06)
- EN 300 440-4 V1.4 (12/02-06)
- EN 300 440-5 V1.4 (12/02-06)
- EN 300 440-6 V1.4 (12/02-06)
- EN 300 440-7 V1.4 (12/02-06)
- EN 300 440-8 V1.4 (12/02-06)
- EN 300 440-9 V1.4 (12/02-06)
- EN 300 440-10 V1.4 (12/02-06)
- EN 300 440-11 V1.4 (12/02-06)
- EN 300 440-12 V1.4 (12/02-06)
- EN 300 440-13 V1.4 (12/02-06)
- EN 300 440-14 V1.4 (12/02-06)
- EN 300 440-15 V1.4 (12/02-06)
- EN 300 440-16 V1.4 (12/02-06)
- EN 300 440-17 V1.4 (12/02-06)
- EN 300 440-18 V1.4 (12/02-06)
- EN 300 440-19 V1.4 (12/02-06)
- EN 300 440-20 V1.4 (12/02-06)
- EN 300 440-21 V1.4 (12/02-06)
- EN 300 440-22 V1.4 (12/02-06)
- EN 300 440-23 V1.4 (12/02-06)
- EN 300 440-24 V1.4 (12/02-06)
- EN 300 440-25 V1.4 (12/02-06)
- EN 300 440-26 V1.4 (12/02-06)
- EN 300 440-27 V1.4 (12/02-06)
- EN 300 440-28 V1.4 (12/02-06)
- EN 300 440-29 V1.4 (12/02-06)
- EN 300 440-30 V1.4 (12/02-06)
- EN 300 440-31 V1.4 (12/02-06)
- EN 300 440-32 V1.4 (12/02-06)
- EN 300 440-33 V1.4 (12/02-06)
- EN 300 440-34 V1.4 (12/02-06)
- EN 300 440-35 V1.4 (12/02-06)
- EN 300 440-36 V1.4 (12/02-06)
- EN 300 440-37 V1.4 (12/02-06)
- EN 300 440-38 V1.4 (12/02-06)
- EN 300 440-39 V1.4 (12/02-06)
- EN 300 440-40 V1.4 (12/02-06)
- EN 300 440-41 V1.4 (12/02-06)
- EN 300 440-42 V1.4 (12/02-06)
- EN 300 440-43 V1.4 (12/02-06)
- EN 300 440-44 V1.4 (12/02-06)
- EN 300 440-45 V1.4 (12/02-06)
- EN 300 440-46 V1.4 (12/02-06)
- EN 300 440-47 V1.4 (12/02-06)
- EN 300 440-48 V1.4 (12/02-06)
- EN 300 440-49 V1.4 (12/02-06)
- EN 300 440-50 V1.4 (12/02-06)
- EN 300 440-51 V1.4 (12/02-06)
- EN 300 440-52 V1.4 (12/02-06)
- EN 300 440-53 V1.4 (12/02-06)
- EN 300 440-54 V1.4 (12/02-06)
- EN 300 440-55 V1.4 (12/02-06)
- EN 300 440-56 V1.4 (12/02-06)
- EN 300 440-57 V1.4 (12/02-06)
- EN 300 440-58 V1.4 (12/02-06)
- EN 300 440-59 V1.4 (12/02-06)
- EN 300 440-60 V1.4 (12/02-06)
- EN 300 440-61 V1.4 (12/02-06)
- EN 300 440-62 V1.4 (12/02-06)
- EN 300 440-63 V1.4 (12/02-06)
- EN 300 440-64 V1.4 (12/02-06)
- EN 300 440-65 V1.4 (12/02-06)
- EN 300 440-66 V1.4 (12/02-06)
- EN 300 440-67 V1.4 (12/02-06)
- EN 300 440-68 V1.4 (12/02-06)
- EN 300 440-69 V1.4 (12/02-06)
- EN 300 440-70 V1.4 (12/02-06)
- EN 300 440-71 V1.4 (12/02-06)
- EN 300 440-72 V1.4 (12/02-06)
- EN 300 440-73 V1.4 (12/02-06)
- EN 300 440-74 V1.4 (12/02-06)
- EN 300 440-75 V1.4 (12/02-06)
- EN 300 440-76 V1.4 (12/02-06)
- EN 300 440-77 V1.4 (12/02-06)
- EN 300 440-78 V1.4 (12/02-06)
- EN 300 440-79 V1.4 (12/02-06)
- EN 300 440-80 V1.4 (12/02-06)
- EN 300 440-81 V1.4 (12/02-06)
- EN 300 440-82 V1.4 (12/02-06)
- EN 300 440-83 V1.4 (12/02-06)
- EN 300 440-84 V1.4 (12/02-06)
- EN 300 440-85 V1.4 (12/02-06)
- EN 300 440-86 V1.4 (12/02-06)
- EN 300 440-87 V1.4 (12/02-06)
- EN 300 440-88 V1.4 (12/02-06)
- EN 300 440-89 V1.4 (12/02-06)
- EN 300 440-90 V1.4 (12/02-06)
- EN 300 440-91 V1.4 (12/02-06)
- EN 300 440-92 V1.4 (12/02-06)
- EN 300 440-93 V1.4 (12/02-06)
- EN 300 440-94 V1.4 (12/02-06)
- EN 300 440-95 V1.4 (12/02-06)
- EN 300 440-96 V1.4 (12/02-06)
- EN 300 440-97 V1.4 (12/02-06)
- EN 300 440-98 V1.4 (12/02-06)
- EN 300 440-99 V1.4 (12/02-06)
- EN 300 440-100 V1.4 (12/02-06)

§2006/95/EC-LVD Directive

- EN 60950-1/A12:2011
- EN 60065:2002 /A12:2011

§2009/128/EC-EPP Directive

- Regulation (EC) No. 2782/2009
- Regulation (EC) No. 642/2009

§2011/65/EU-ROHS Directive

- RoHS marking**



(EC conformity marking)

Position : **CEO**
Name : **Jerry Shan**

Jerry Shan

Signature : _____

Declaration Date: **12/04/2013**
Year to begin affixing CE marking: **2013**

Ver. 130269