

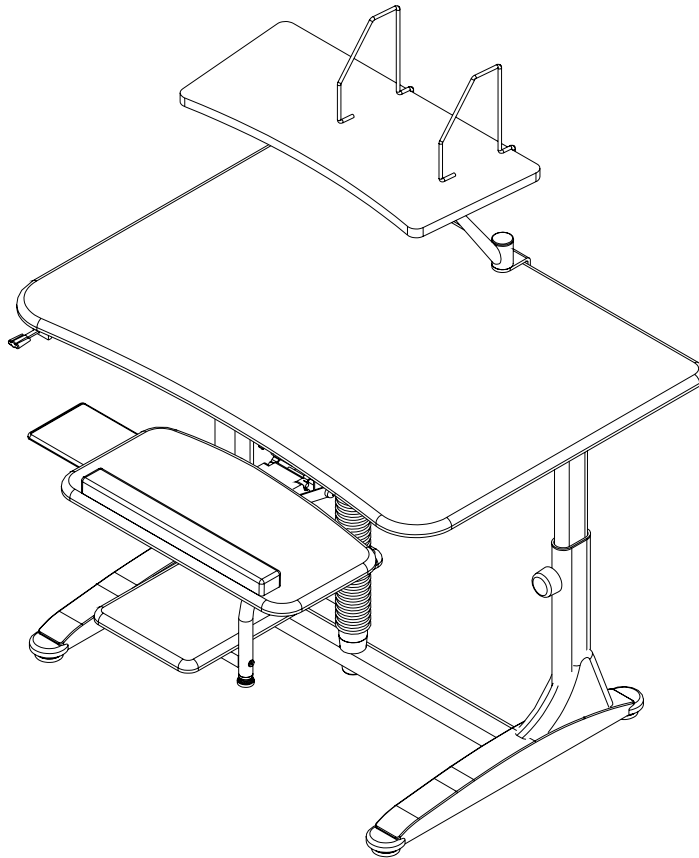

BLT-82493 ERGO-E.EAZY

True Adjust® Pneumatic Computer Desk



Assembly Instructions



Part	Drawing	Description	Qty	Part	Drawing	Description	Qty
P1		Top Platform	1 EA	P11		Cable Management Tray	1 EA
P2		Upper Leg Insert	2 EA	P12		Keyboard Platform	1 EA
P3		Leg Receiver (Right)	1 EA	P13		Metal Keyboard Track	1 EA
P4		Leg Receiver (Left)	1 EA	P14		Keyboard Mechanism	1 EA
P5		Height Adjust Bracket	1 EA	P15		Metal Mouse Platform	1 EA
P6		Leg Brace	1 EA	P16		Metal Mouse Bar	1 EA
P7		CPU Platform	1 EA	P17		Wrist Rest	1 EA
P8		CPU Support Leg	1 EA	P18		Printer Platform	1 EA
P9		CPU Foot	2 EA	P19		Shelf Bracket	2 EA
P-10		Cylinder Extension	1 EA	P20		Wire CD/Book Support	2 EA

Tools required:
 Philips Head Screw Driver
 (Power Screw Driver Preferred)

*We recommend that you assemble
 this unit on a table.*



Hardware List

Part	Drawing	Description	Qty			
A		Screw 6MM x 13	19 EA	E		Cylinder w/Plastic cover 1 EA
A1		Screw 6MM x 40	8 EA	F		Rubber Bumper 2 EA
A2		Screw 8MM x 40	4 EA	G		Desk Glide 2 EA
B		Short Wood Screw	21 EA	H		Large CPU Glide 2 EA
B1		Long Wood Screw	2 EA	J		Small CPU Glide 2 EA
C		Hex Head Screw	2 EA	K		Allen Wrench 1 EA
D		Flat Washer	2 EA	L		Adjustment Knob 2 EA

READ THROUGH INSTRUCTIONS FROM BEGINNING TO END BEFORE STARTING TO ASSEMBLE UNIT.

1. Identify and Separate all Parts and Hardware.

2. Attach 2 each CPU Feet (P-9) to the CPU Platform (P-7) using 2 each Screws (A1) and 2 each washers (D) as shown in illustration #1.

3. Attach 1 each CPU Support Leg (P-8) to the 2 each CPU Feet (P-9) using 2 Screws (A1) as shown in illustration #1.

4. Insert 2 each large CPU Glides (H) into the 2 each CPU Feet (P-9) as shown in illustration #1.

5. Insert 2 each small CPU Glides (J) into the bottom of 1 each CPU Support Leg (P-8) as shown in illustration #1.

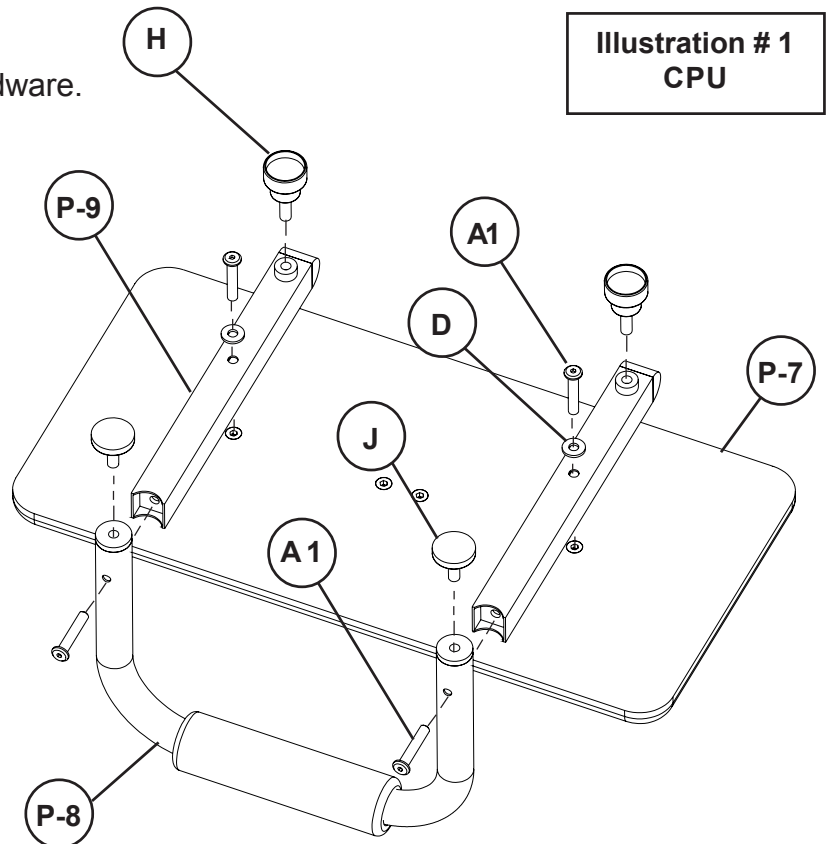

**Illustration # 1
CPU**

Ergo E.Eazy Assembly Diagram

Missing Parts or UPS Damaged Parts

For Your Convenience you can
EMAIL us at

furniture@baltinc.com

24HOURS 7 DAYS A WEEK

6. Place the Top Platform (P-1) with the insert nuts facing up. Attach Cable Management Tray (P-11) to the Top Platform (P-1) using 3 (A) Screws as shown in illustration #2.
7. Attach Height Adjust Bracket (P-5) to the Top Platform (P-1) using 4 (A) Screws as shown in illustration #2. *(Do not tighten screws all the way)*

Height Adjustment Lever may be mounted to the left or the right side of the Top Platform (P-1).
[Keyboard Platform is mounted on the opposite side.]

8. After choosing which side, secure Height Adjust Lever (attached to P-5) to the Top Platform (P-1) using 3 (B) Screws as shown in illustration #2.

Illustration # 2

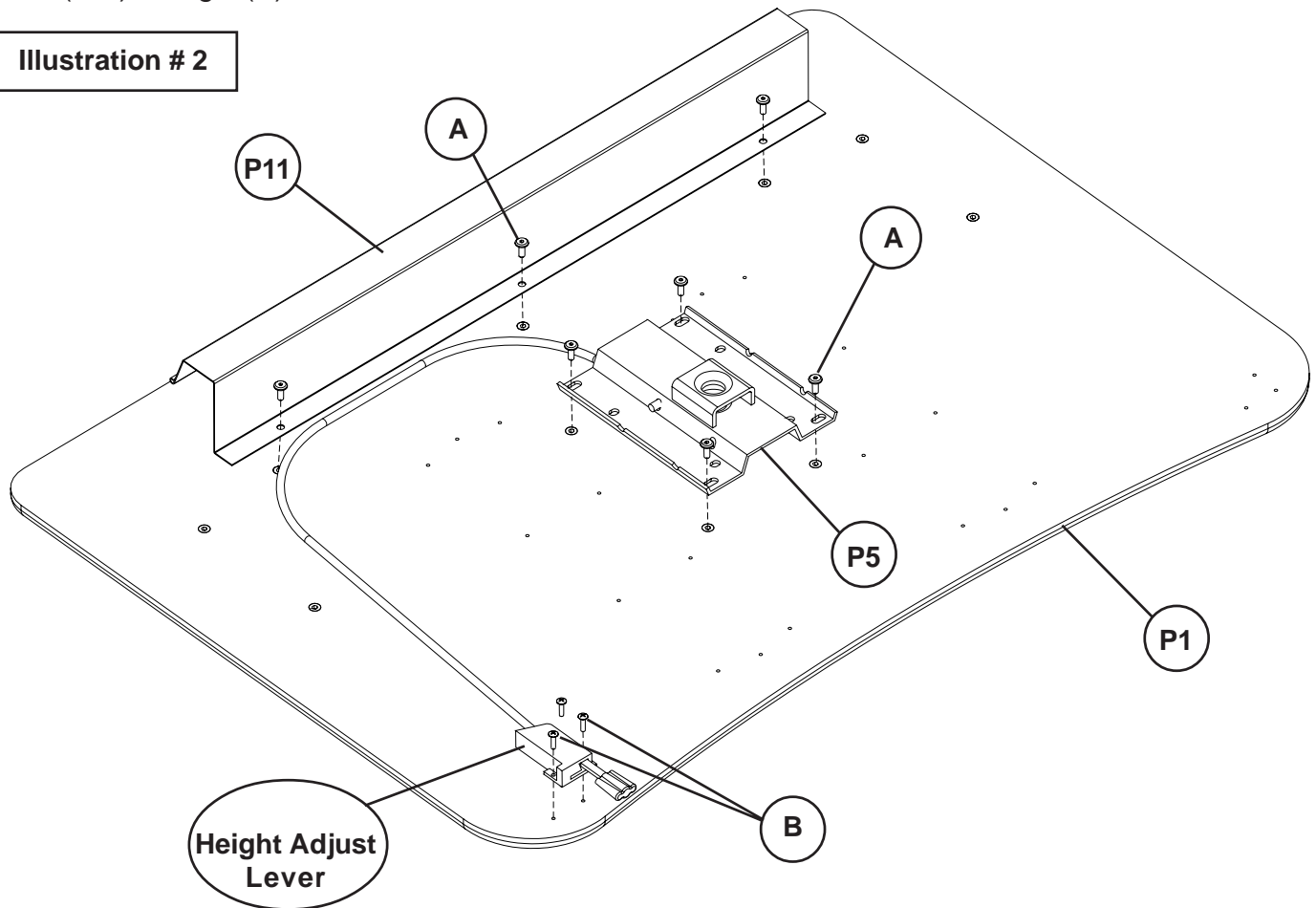

Do not use unless all screws are tight. At least every six months, check all screws to be sure they are tight. If parts are missing, broken, damaged, or worn, stop use of the product until repairs are made by your dealer using factory authorized parts.

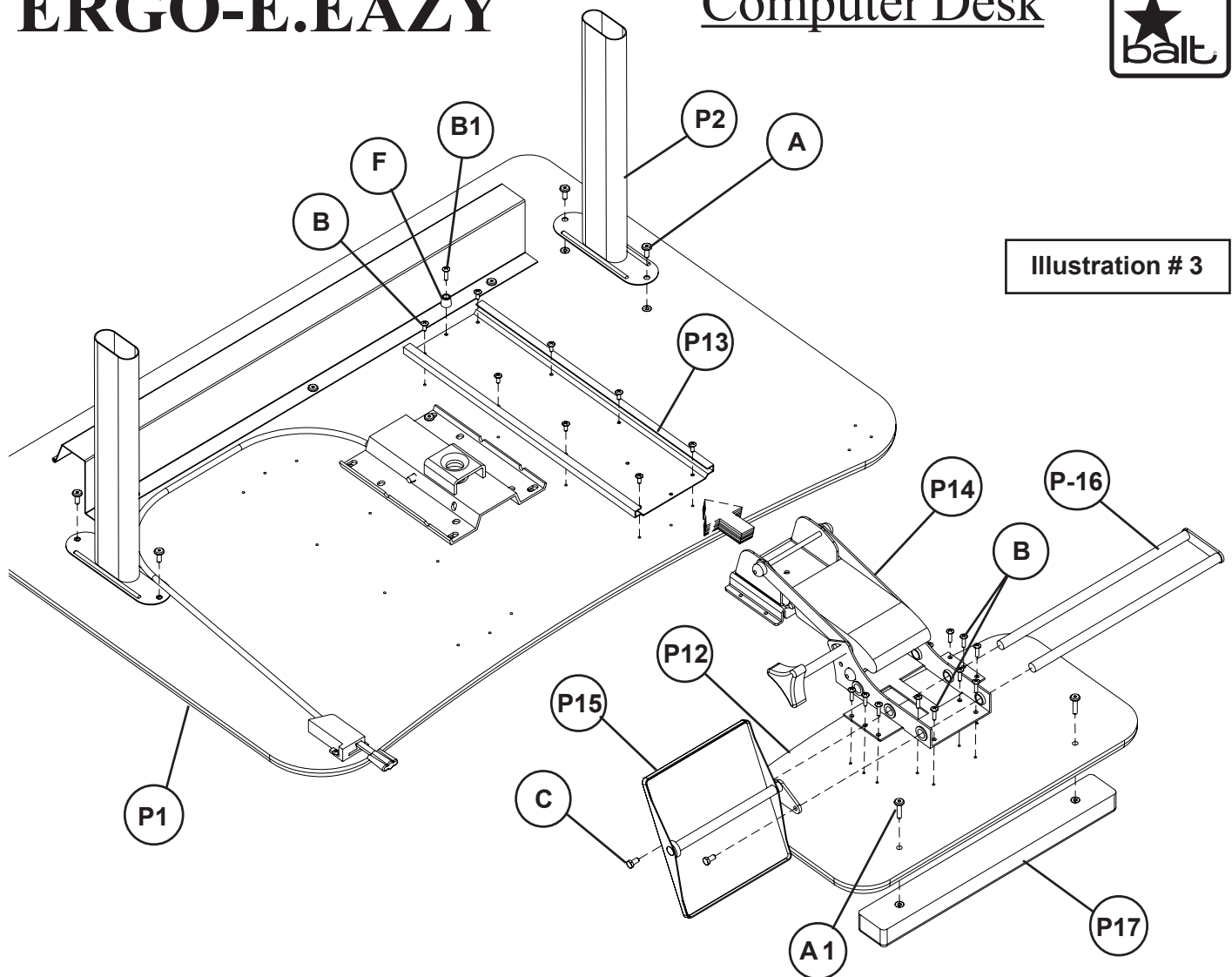
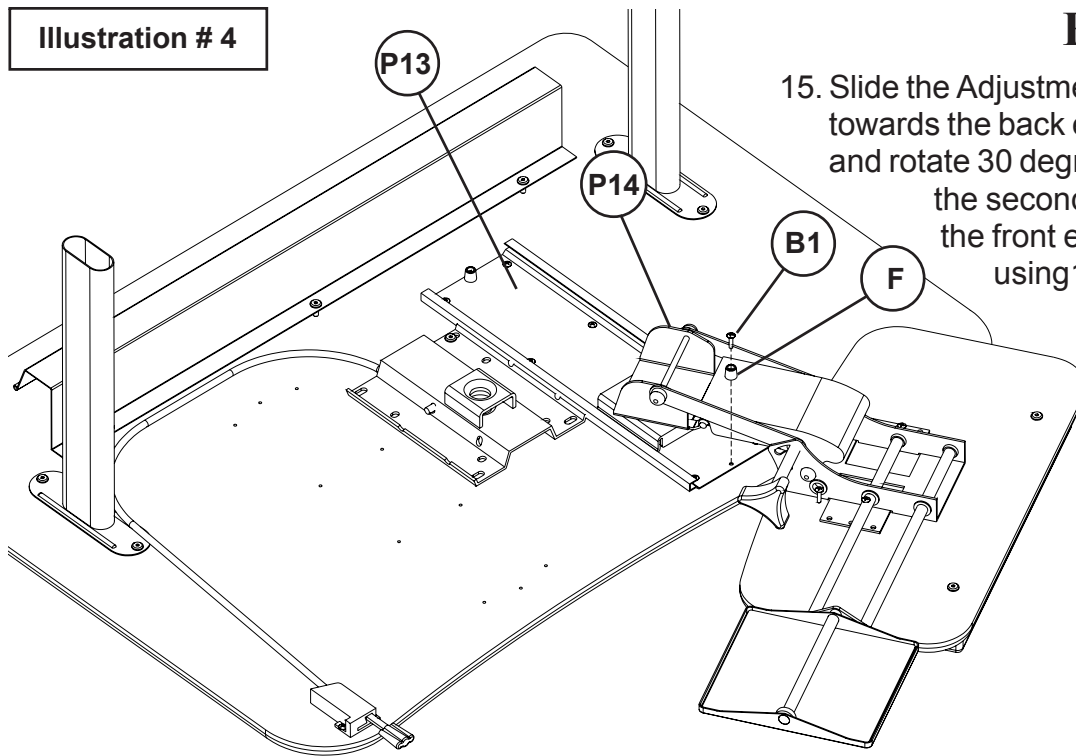

Illustration # 3

9. Attach 2 each Upper Leg Inserts (P-2) to the Top Platform (P-1) using 4 (A) Screws as shown in illustration #3. *(Do not tighten screws all the way)*
10. Align the Keyboard Track (P-13) in desired location on the Top Platform (P-1) and attach it using 8 Short Wood Screws (B) as shown in illustration # 3.
11. Attach Rubber Bumper (F) at the back end of the Keyboard Track (P-13) using 1 Long Wood Screw (B1) . Slide the Adjustment Mechanism (P-14) into the track as shown in illustration #3.
12. Align screw holes in Adjustment Mechanism (P-14) with screw holes in the Keyboard Platform (P-12) and attach using 10 each Wood Screws (B) as shown in illustration # 3.
13. Mouse Platform (P-15) may be installed on the right or left side of Keyboard Mechanism (P-14). Slide Mouse Bar (P-16) through Keyboard Mechanism (P-14) and attach to Mouse Platform (P-15) using 2 each Hex Head Screws (C) as shown in illustration #3.
14. Attach Wrist Rest (P-17) to the Keyboard Platform (P-12) using 2 Screws (A1) as illustrated.

Illustration # 4



ERGO-E.EAZY

15. Slide the Adjustment Mechanism (P-14) towards the back end of the Track (P-13) and rotate 30 degrees as shown. Attach the second Rubber Bumper (F) at the front end of Track (P-13) using 1 each Long Wood Screw (B1) as shown in illustration # 4.



16. Attach 1 each Right Leg Receiver (P-3) and 1 each Left Leg Receiver (P-4) to the Leg Brace (P-6) using 4 (A2) Screws as shown in illustration #5. (Do not tighten screws all the way)

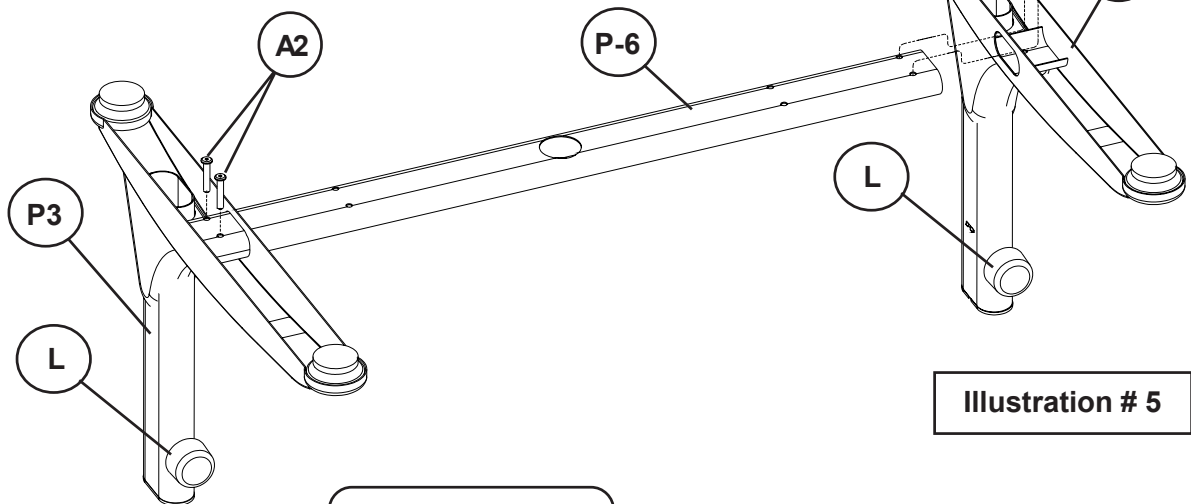
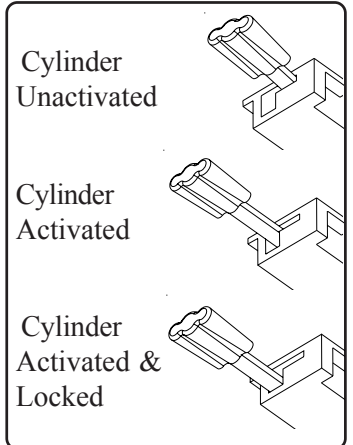

Illustration # 5

Height Adjustment

To raise height of unit, loosen both adjustment knobs (K) and press handle on height adjustment lever to the left and down. This locks the pneumatic cylinder in the activated position and it will begin lifting the unit. When the unit reaches the desired height, move handle up and to the right. This locks the pneumatic cylinder in the closed position. Secure unit at desired height by tightening both adjustment knobs (K).

To lower height of unit, loosen both adjustment knobs (K) and press handle on height adjustment lever to the left and down. Press on center of Top Platform using body weight. Top Platform will lower and you can release handle by moving handle up and to the right at the desired height. Secure unit at desired height by tightening both adjustment knobs (K).



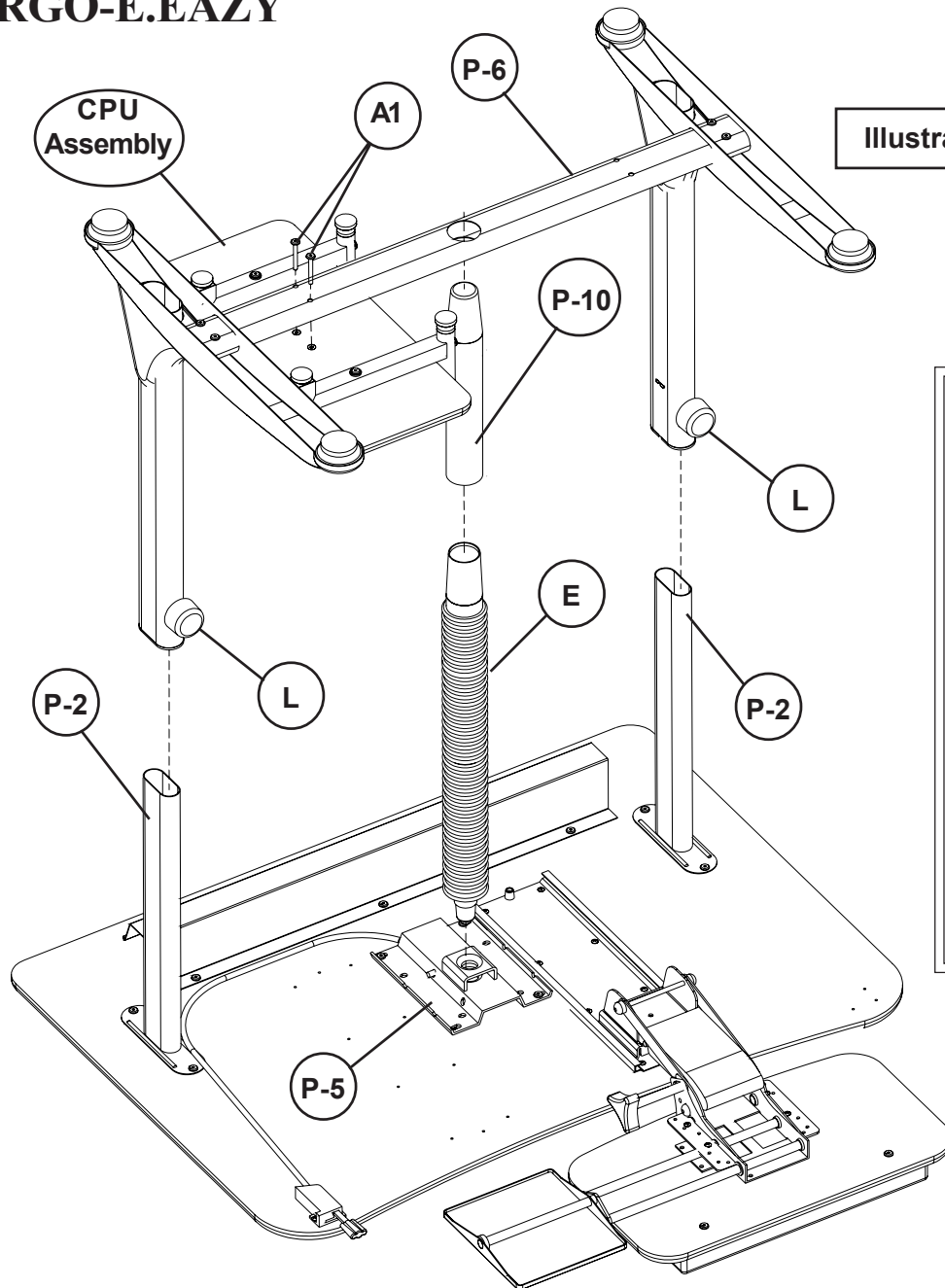
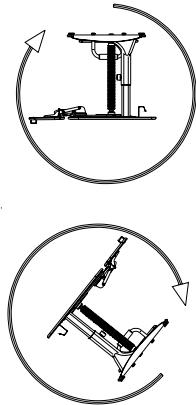

Illustration # 6

Be sure the Adjustment Knobs (L) are secured before rotating unit to the upright position.



17. Insert Cylinder w/Plastic Cover (E) into Height Adjust Bracket (P-5) as shown in illustration #6.
18. Slide Cylinder Extension (P-10) over Cylinder(E).
19. Slide Lower Leg Assembly over the Upper Leg Inserts (P-2) as shown in illustration #5. (Make sure Cylinder Extension (P-10)slides into hole in Leg Brace (P-6) as shown in illustration #6.)
20. Secure using 2 each Adjustment Knobs (L) as shown.
21. Attach CPU Assembly to the Leg Brace (P-6) using 2 each Screws (A1) as shown in illustration #6.
22. Tighten all screws using Allen Wrench (K).

EazyShelf Assembly Diagram



23. Place the Printer Platform (P-18) with the insert nuts facing up. Attach 2 each Shelf Brackets (P-19) to the Top Platform (P-18) using 8 each (A) Screws as shown in illustration #7.

Illustration # 7

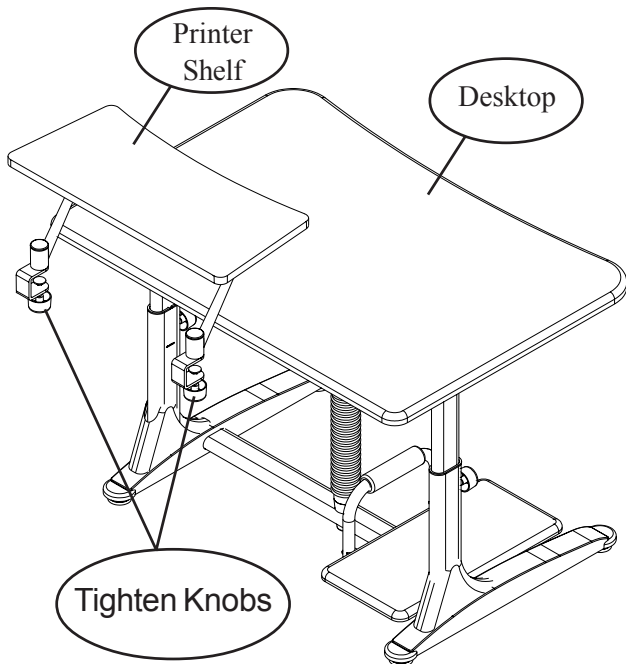
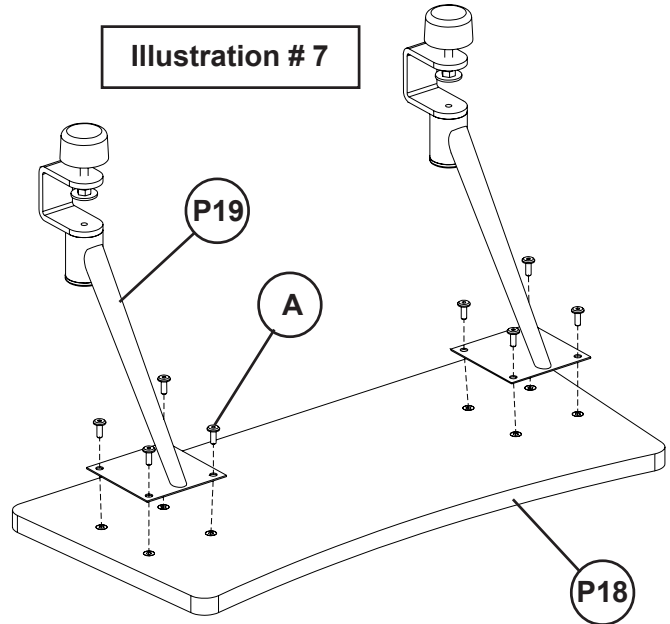
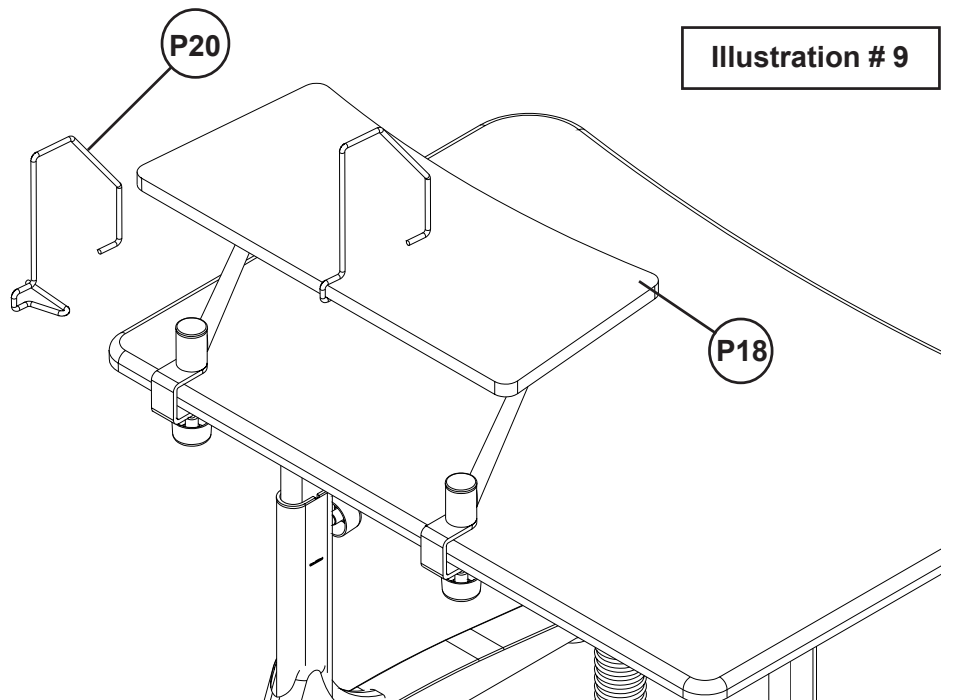

Illustration # 8

24. Place the Printer Shelf over the back edge of the Desktop and secure by tightening the knobs as shown in illustration #8.

25. Attach 2 each CD/Book Supports (P-20) by sliding them over the back edge of shelf (P-18) as shown in illustration #9.

Illustration # 9



ERGO-E.EAZY

Adjustable Pneumatic Computer Desk



For more information
1-800-749-2258

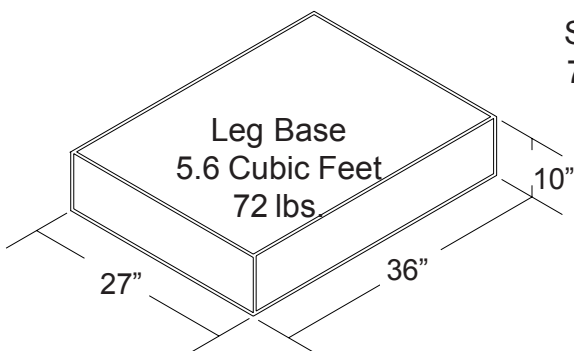
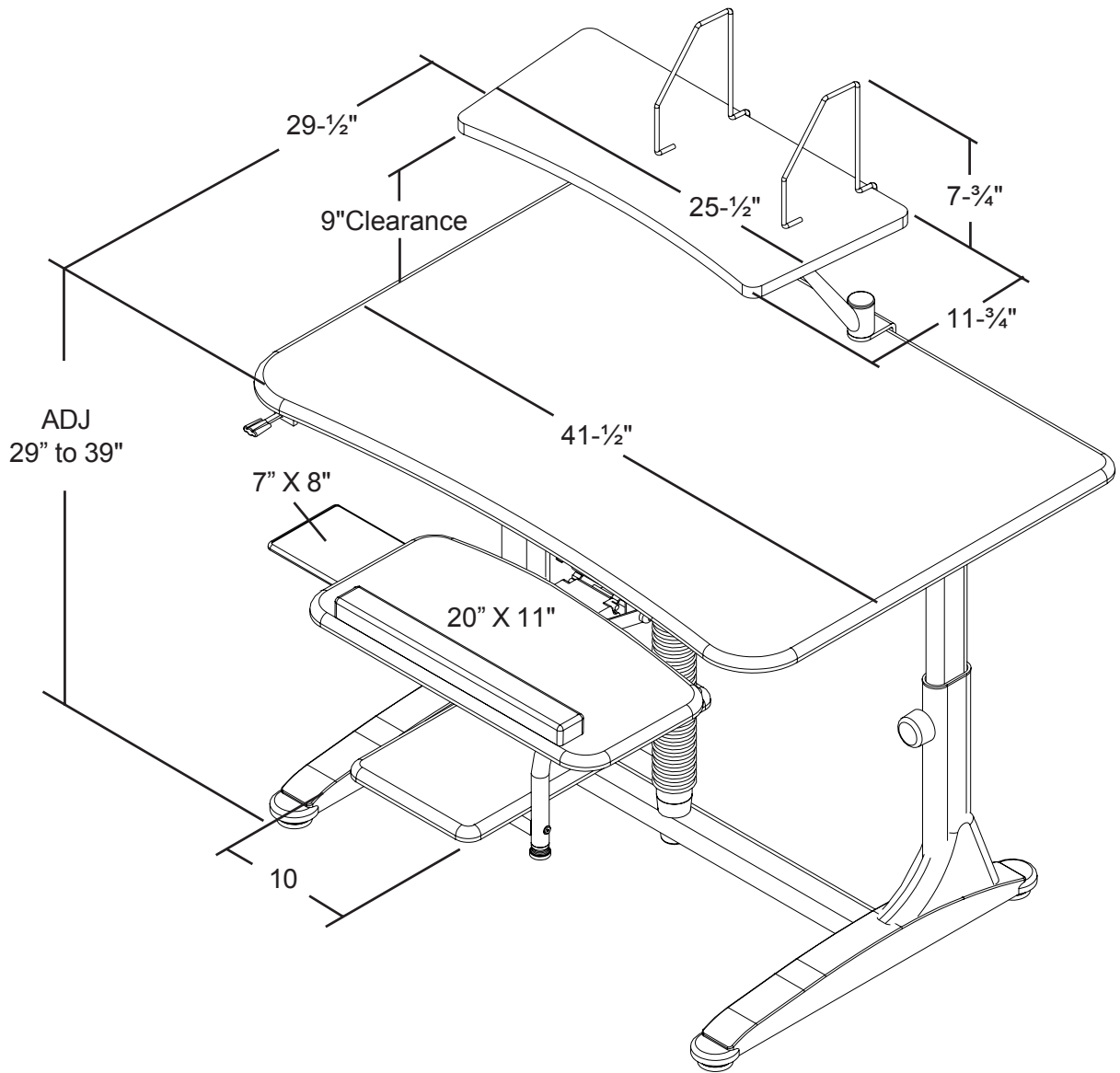

Shipping Information
7.3 Total Cubic Feet
99 lbs. total weight

