

Rosewill[®]



FB-03/04

User's Manual

Contents

- **Product Overview**
 - Disassemble Chart ----- **P.2**
 - Accessory Box ----- **P.3**
- **Installation Guide**
 - Opening Chassis ----- **P.4**
 - Installing 2.5" HDD/SSD ----- **P.4**
 - Installing Power Supply ----- **P.5**
 - Installing Motherboard ----- **P.5**
 - Installing Add-On Card ----- **P.6**
 - Installing External 5.25"/3.5" Device ----- **P.7**
 - Installing 3.5" HDD ----- **P.8**
 - Closing Chassis ----- **P.9**
- **Information** ----- **P.9**



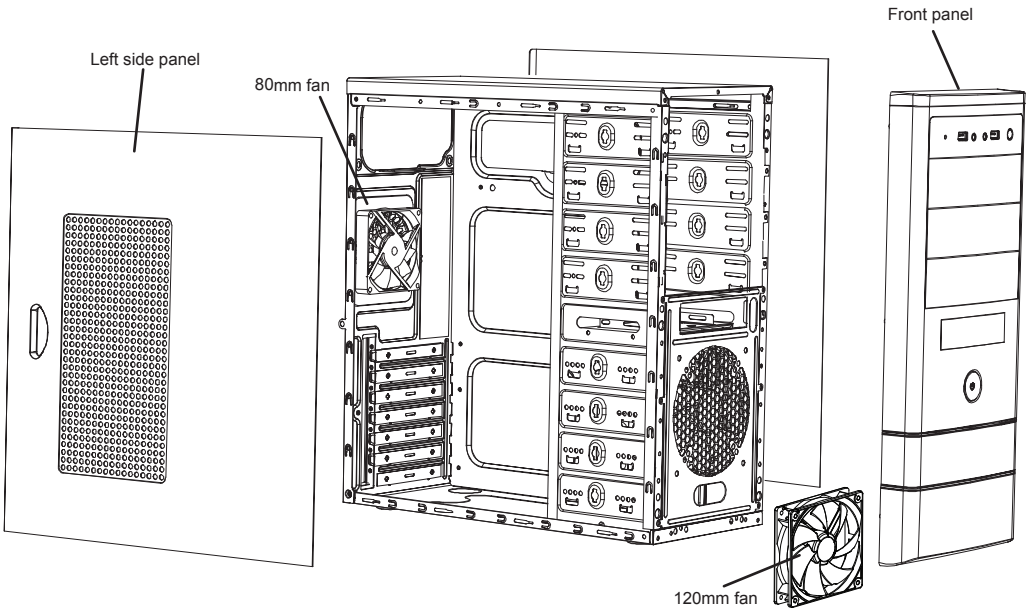



Disassemble Chart (For reference only. Models' option may be varied by countries.)

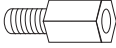

Front I/O Pin Define (Please refer to your motherboard's user's manual to connect.)

HD CONNECTOR	AC97 CONNECTOR
<p>AUD GND [X] [X] PORT1L PRESENCE# [X] [X] PORT1R SENSE1 RETURN [X] [X] PORT2R NO PIN [X] [X] SENSE SEND SENSE2 RETURN [X] [X] PORT2L</p> <p>NO PIN</p>	<p>MIC [X] [X] MIC AUD GND [X] [X] MIC-BIAA RET-R [X] [X] FPOUT-R NO PIN [X] [X] +5V RET-L [X] [X] FPOUT-L</p> <p>NO PIN</p>
USB2.0 CONNECTOR	
<p>USB+5V [X] [X] USB+5V LP [X] [X] LP LP+ [X] [X] LP+ GND [X] [X] GND NC [X] [X] NO PIN</p> <p>NO PIN</p>	

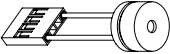
Accessory Box

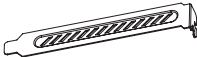
	9 x M/B standoff	Motherboard
	29 x screw-A	Motherboard 5.25"/3.5" Device 2.5" SSD/HDD
	16 x screw-B	3.5" HDD
	11 x screw-C	Power Supply Add-on Card
	1 x PC SPEAKER	Motherboard
	5 x Cable tie	Cables
	2 x PCI cover	Expansion Slot

1. Opening Chassis

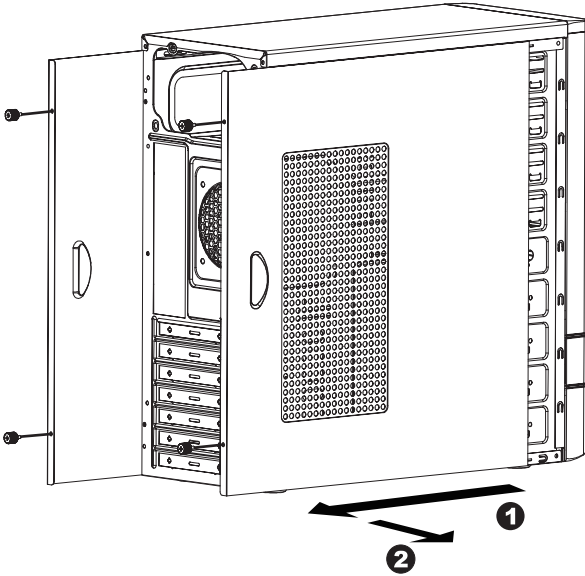

Unscrew to remove left and right panels.

2. Installing 2.5" HDD/SSD

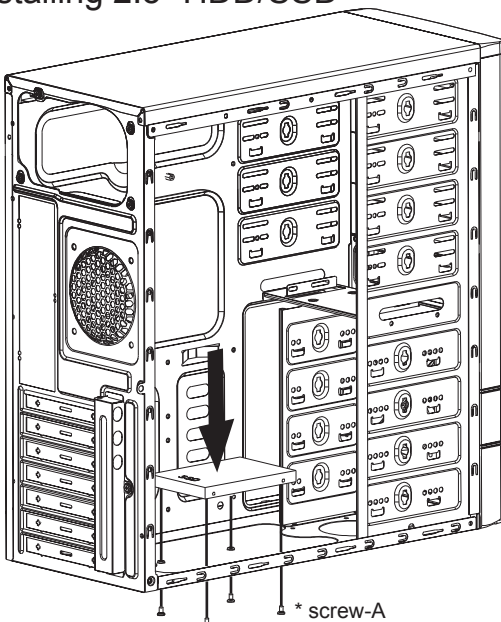

Place 2.5" HDD/SSD onto the bottom of the chassis and secure with screws.

3. Installing Power Supply

* screw-C

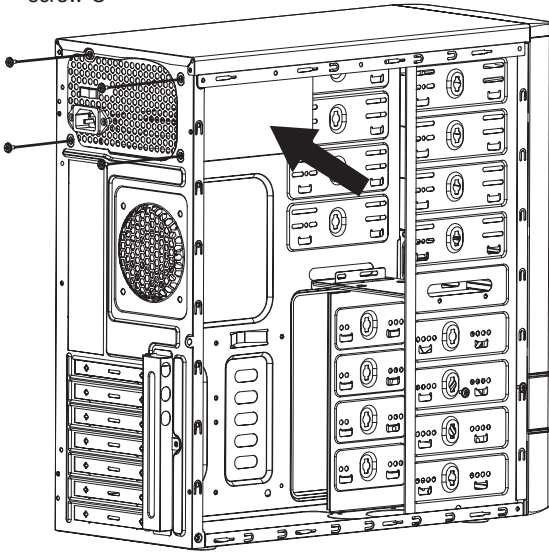

Place the power supply from the left side into the chassis and secure with screws.

NOTICE :

-If your power supply is equipped with single fan (120mm, 135mm or 140mm), please have the fan face to the bottom.

4. Installing Motherboard

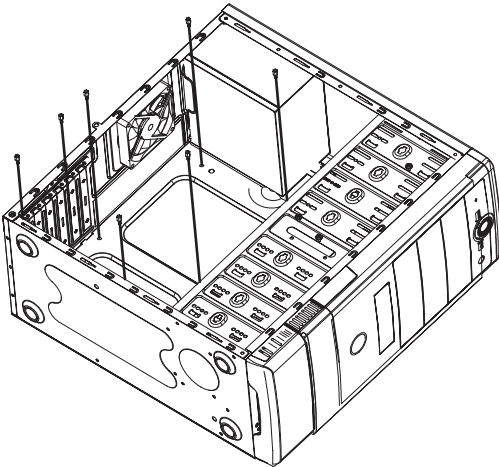

Step 1- Install motherboard stand-offs according to your motherboard's form factor.

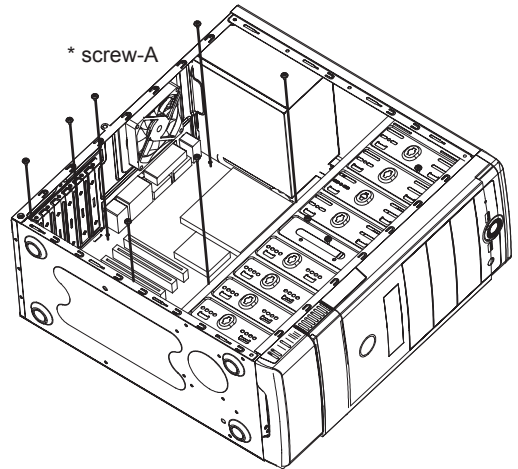

Step 2- Place the motherboard onto stand-offs and secure with screws.

NOTE : NOT every motherboard is made by standard, please set stand-offs according to your motherboard.

5. Installing Add-On card

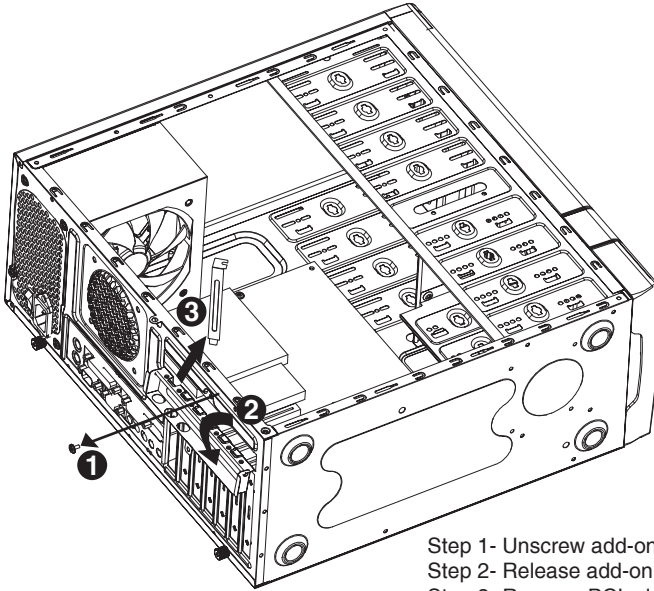

- Step 1- Unscrew add-on card cover.
- Step 2- Release add-on card cover.
- Step 3- Remove PCI slot cover.

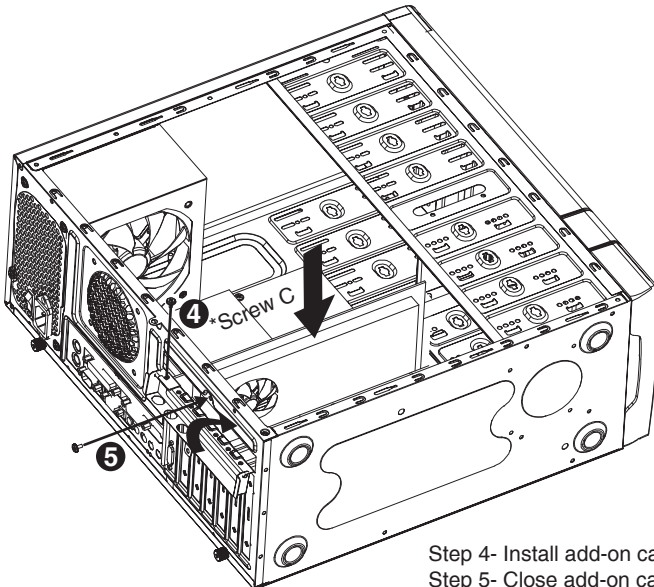

- Step 4- Install add-on card and secure with screw.
- Step 5- Close add-on card cover and secure with screw.

6. Installing External 5.25"/3.5" Device

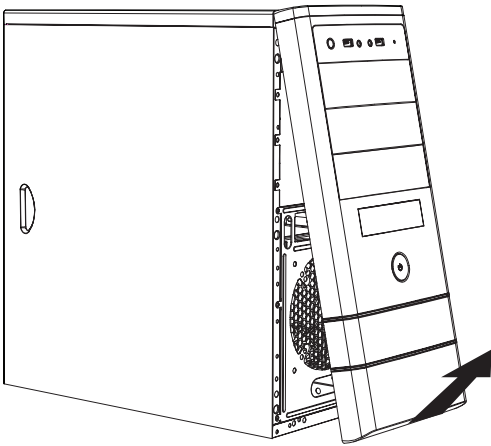

-Remove front panel by pulling from the bottom as shown.

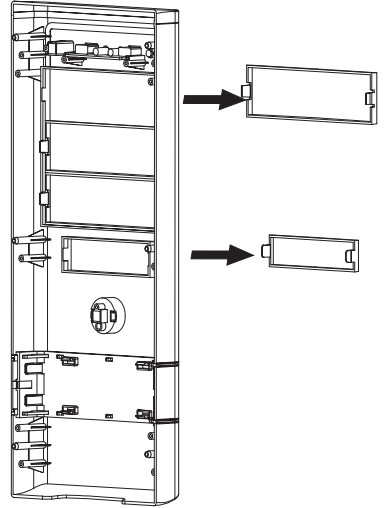

-Confirm which bay(s) you want to install device(s) then remove the bay cover.

7. Installing External 5.25"/3.5" Device

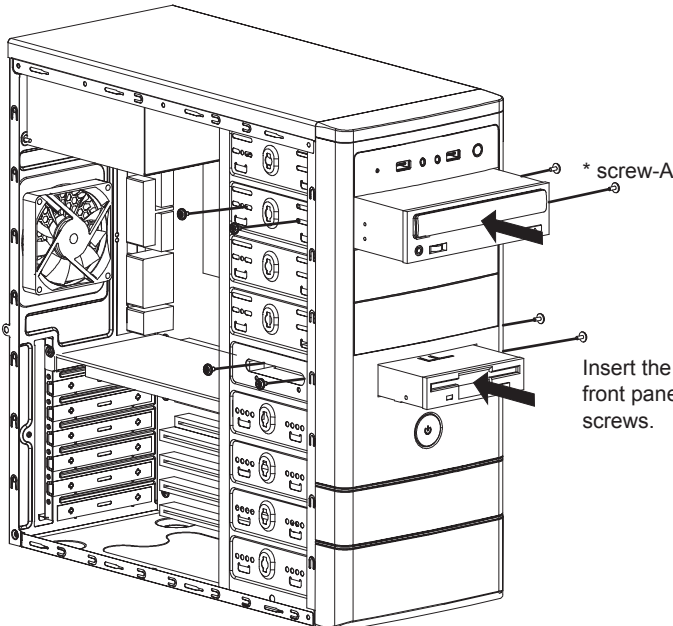

Insert the external 5.25" & 3.5" device from the front panel into the chassis then secure with screws.

8. Installing 3.5" HDD

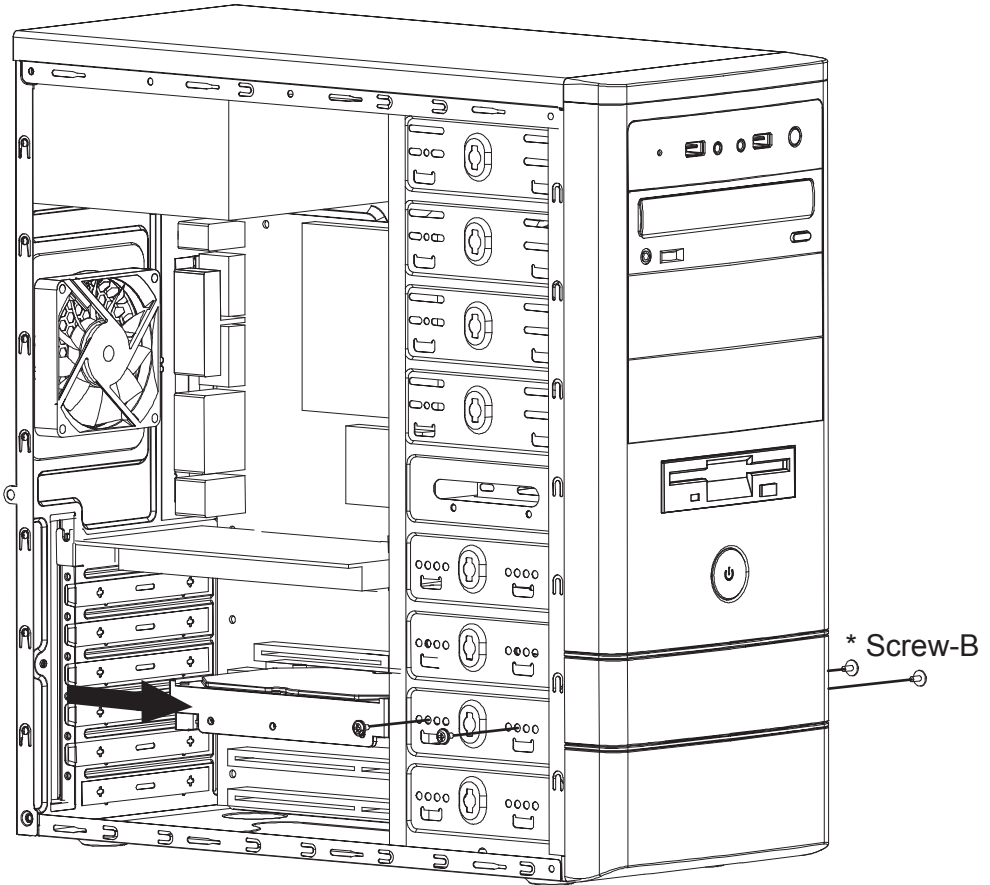

Place the 3.5" HDD into the HDD tray then secure with screws.

9. Closing Chassis

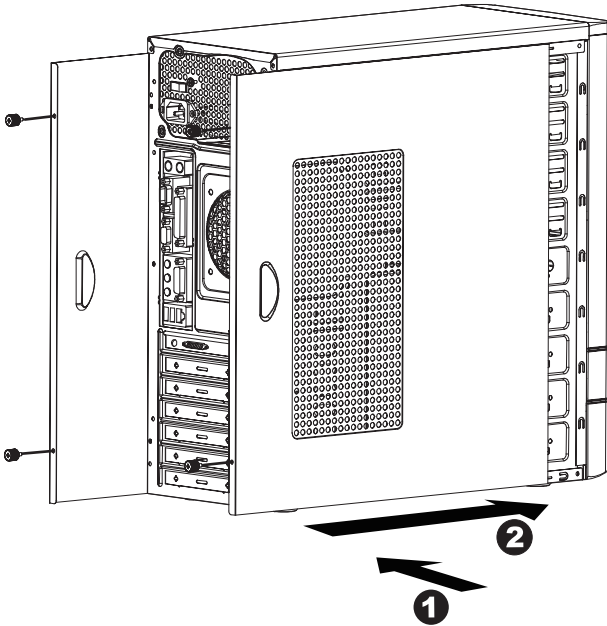

Make sure all necessary cables and wires are connected, then reinstall side panels and secure with screws.

Thank you for purchasing a High-Quality Rosewill Product.

Please register your product at : <http://www.rosewill.com>
for complete warranty information and future support for your product.

If you have any question while using our products, please visit our website : www.rosewill.com
for latest driver & user manual or feel free to contact us.

Support Phone Number: 800-575-9885

Support Email: techsupport@rosewill.com

Rosewill[®]