

Flat Panel Ceiling Mount

For 32" to 71" LCD and Plasma Screens



FLAT PANEL MOUNTS

1. 0° to 20° adjustable tilt and 360° swivel
2. Uses standard 1.5" (38.1 mm) NPT pipe
3. Mounts screen vertically or horizontally
4. Simple hook-on screen installation



For expanded product information and technical data visit www.peerlessmounts.com

TECHNICAL DRAWINGS

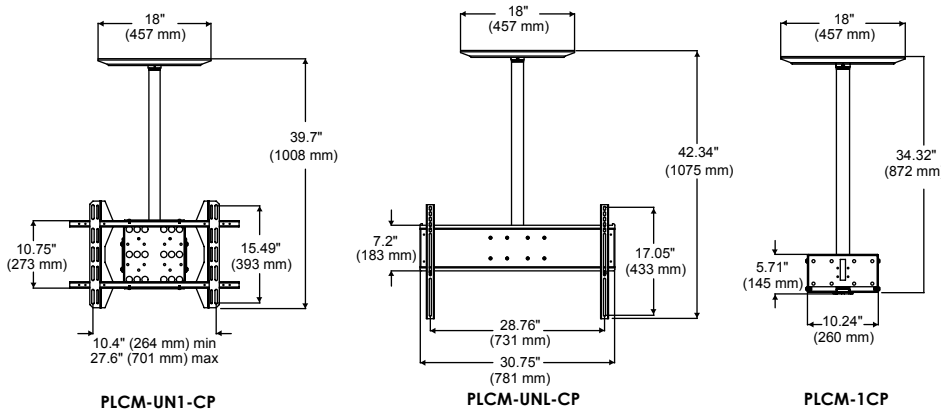

Model	Screen Size	Width	Height	Depth	Contents	Max Load	Ship Weight
PLCM-UNL-CP	32"-60"	30.75" (781 mm)	42.34" (1075 mm)	4.43" (112 mm)	Ceiling plate, adapter, column, base mount	200 lb (90 kg)	33.3 lb (15.1 kg)
PLCM-UNL	32"-60"	30.75" (781 mm)	41.54" (1055 mm)	4.43" (112 mm)	Adapter, column, base mount	200 lb (90 kg)	30.3 lb (13.74 kg)
PLCM-UN1-CP	32"-50"	27.6" (701 mm)	39.7" (1008 mm)	3.92" (99 mm)	Ceiling plate, adapter, column, base mount	125 lb (56 kg)	30.1 lb (13.6 kg)
PLCM-UN1	32"-50"	27.6" (701 mm)	38.91" (988 mm)	3.92" (99 mm)	Adapter, column, base mount	125 lb (56 kg)	27.4 lb (12.4 kg)
PLCM-1CP	Up to 71"	18" (457 mm)	34.32" (872 mm)	3.61" (91 mm)	Ceiling plate, column, base mount	225 lb (102 kg)	18.7 lb (8.4 kg)
PLCM-1	Up to 71"	10.24" (260 mm)	33.5" (850 mm)	3.25" (82 mm)	Column, base mount	225 lb (102 kg)	16 lb (7.2 kg)
PLCM-2	Up to 71"	10.24" (260 mm)	5.71" (145 mm)	3.25" (82 mm)	Base mount	225 lb (102 kg)	7.5 lb (3.4 kg)

MODELS

Universal Models: (See chart for screen size compatibility)

Includes theft resistant hardware for attaching screen to mount

PLCM-UNL-CP	Black
PLCM-UNL	Black
PLCM-UN1-CP	Black
PLCM-UN1	Black

Dedicated Models: (See chart for screen size compatibility)

Screen Adapter Purchased Separately*

PLCM-1	Black
PLCM-1CP	Black
PLCM-2	Black

* Dedicated adapter plates come in flat black and include security fasteners

SCREEN ADAPTER



Mounting pattern

Universal PLCM-UNL Models: 28.76" W x 17.05" H (731 x 433 mm)

Universal PLCM-UN1 Models: 27.6" W x 15.49" H (701 x 393 mm)

Dedicated Models: Requires screen-specific adapter to be purchased separately

SPECIFICATIONS



Distance from ceiling

See chart



Tilt | Swivel

+20° | 360°



Max load

See chart

Product Dimensions (W x H x D)

See chart

Mounting Surfaces

Wood joist, concrete and various other applications (May require accessory)

Ship Weight

See chart

CERTIFICATIONS



ACCESSORIES



ACC, CMJ, DCS, DCT Models:
Ceiling Plates pg# 125-127



AEC, EXT Models:
Ceiling Extensions pg# 127

To verify mount compatibility with any LCD, plasma or projector model use MountFinder™ at www.peerlessmounts.com

CLICK: www.peerlessmounts.com

CALL: 800.865.2112

FAX: 708.865.2941