

Panasonic

Operating Instructions

Network Camera

Model No. WV-SW395, WV-SC385

WV-SC384

WV-SW395E, WV-SC385E

WV-SC384E

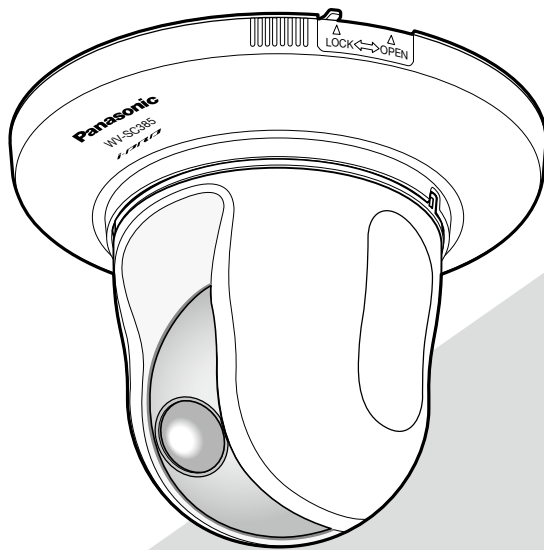

WV-SC385/WV-SC384



WV-SW395



Before attempting to connect or operate this product,
please read these instructions carefully and save this manual for future use.

The model number is abbreviated in some descriptions in this manual.

CONTENTS

Preface	4	Configure the settings relating to the aspect ratio [JPEG/H.264].....	47
About the user manuals	4	Configure the settings relating to JPEG images [JPEG/H.264] (or [JPEG/MPEG-4]).....	47
About notations	4	Configure the settings relating to H.264 images [JPEG/H.264].....	49
Trademarks and registered trademarks	4	Configure the settings relating to MPEG-4 images [JPEG/MPEG-4]	53
Abbreviations	5	Configure the settings relating to the camera operations [Cam. Function].....	56
Viewer software	5	Configure the settings relating to images and the preset positions [Image/Position].....	58
Monitor images on a PC.....	6	Configure the settings relating to image quality ("Image adjust" setup menu) SW395 SC385	59
Monitor images from a single camera.....	6	Configure the settings relating to image quality ("Image adjust" setup menu) SC384	63
About the "Live" page	8	Set mask areas.....	66
Monitor images from multiple cameras.....	13	Configure the settings relating to the preset positions ("Preset position" setup menu).....	67
Monitor images on a cellular phone	14	Register the preset positions	68
Record images on the SD memory card manually....	16	Configure the settings relating to the auto pan function ("Auto pan" setup menu).....	70
Action at an alarm occurrence	17	Configure the settings relating to the privacy zone ("Privacy zone" setup menu).....	71
Alarm type	17	Configure the settings relating to audio [Audio]....	72
Action at an alarm occurrence	17	Configure the multi-screen settings [Multi-screen] ...	74
Transmit images onto an FTP server.....	18	Configure the alarm settings [Alarm]	75
Transmit an alarm image at an alarm occurrence (Alarm image transmission)	18	Configure the settings relating to the alarm action [Alarm]	75
Transmit images at a designated interval or period (FTP periodic image transmission)	18	Configure the settings relating to the camera action on alarm occurrence [Alarm]	76
Save images on the SD memory card when images fail to transmit using the FTP periodic image transmission function	19	Configure the settings relating to the alarm image [Alarm]	77
Display the log list	20	Configure the settings relating to H.264 recording [Alarm]	78
About the log list window	20	Configure the settings relating to the alarm output terminal [Alarm]	79
Playback of images on the SD memory card.....	22	Change the AUX name [Alarm].....	80
About the playback page	22	Configure the VMD settings [VMD area].....	80
Download the images	24	Set the VMD areas [VMD area].....	82
(When "H.264" is selected for "Recording format" of the SD memory card)	24	Configuration of the settings relating to the mail notification [Notification].....	83
About the network security	25	Configure the settings relating to Panasonic alarm protocol [Notification]	84
Equipped security functions.....	25	Configure the setting relating to the image recognition [Advanced func.]	85
Display the setup menu from a PC	26	Configure the settings relating to the XML notification [XML notification].....	85
How to display the setup menu	26	Configuration of the destination settings of the face detection [XML notification]	85
How to operate the setup menu	27		
About the setup menu window	28		
Configure the basic settings of the camera [Basic]...	30		
Configure the basic settings [Basic].....	30		
Configure the settings relating to the SD memory card [SD memory card]	33		
Access copy images saved on the SD memory card onto the PC [SD memory card images].....	38		
Configure the settings relating to the logs [Log] ...	43		
How the logs and images are saved depending on the settings for "Alarm"	44		
How the logs and images are saved depending on the settings for "Manual/Schedule"	45		
How the logs and images are saved depending on the settings for "FTP error"	46		
Configure the settings relating to images and audio [Image/Audio]	47		

Configure the settings relating to the authentication [User mng.]	87	Check the status [Status]	124
Configure the settings relating to the user authentication [User auth.]	87	Reset the settings/Reboot the camera [Default reset] 125	
Configure the settings relating to the host authentication [Host auth.]	88	Viewing Help.....	126
Configure the settings relating to the priority stream [System].....	89	Displaying the Help screen.....	126
Configure the settings of the servers [Server]	90	About the displayed system log.....	127
Configure the settings relating to the mail server [Mail].....	90	Troubleshooting.....	130
Configure the settings relating to the FTP server [FTP]	91	Directory structure of drive B	141
Configure the settings relating to the NTP server [NTP].....	92		
Configuring the network settings [Network].....	93		
Configure the network settings [Network].....	93		
Configure the HTTPS settings.....	99		
Generation of the CRT key (SSL encryption key)...	100		
Generation of the self-signed certificate (security certificate).....	101		
Generation of CSR (Certificate Signing Request) ..	103		
Installation of the server certificate	104		
Configuration of the connection protocol	105		
Access the camera using the HTTPS protocol ...	106		
Install the self-signed certificate (security certificate).....	106		
Configure the settings relating to DDNS [DDNS]	111		
Configuration of the DDNS service (Example of the "Viewnetcam" service)	112		
When using the "Viewnetcam" service	113		
Procedure to register information for the "Viewnetcam" service	114		
Checking the information registered for the "Viewnetcam" service	114		
When using "Dynamic DNS Update"	115		
When using "Dynamic DNS Update(DHCP)" ...	115		
Configure the settings relating to SNMP [SNMP]	116		
Configure the settings relating to the FTP periodic image transmission [FTP img. trans.].....	116		
Configure the schedule settings of the FTP periodic image transmission [FTP img. trans.].....	118		
How to set the schedules.....	118		
How to delete the set schedule	119		
Configure the settings relating to the schedules [Schedule].....	120		
Maintenance of the camera [Maintenance]	121		
Check the system log [System log].....	121		
Upgrade the firmware [Upgrade].....	122		

Preface

About the user manuals

There are 2 sets of operating instructions for the WV-SC384, WV-SC385, WV-SW395 (NTSC model), WV-SC384E, WV-SC385E, WV-SW395E (PAL model) as follows.

- Installation Guide: Explains how to install and connect devices.
When you use the WV-SC385/WV-SC385E or WV-SC384/WV-SC384E, refer to WV-SC385/ WV-SC385E/ WV-SC384/ WV-SC384E Installation Guide.
When you use the WV-SW395 or WV-SW395E, refer to WV-SW395/WV-SW395E Installation Guide.
- Operating Instructions (PDF): Explains how to perform the settings and how to operate this camera.
This Operating Instructions covers the models: WV-SW395, WV-SC385, WV-SC384, WV-SW395E, WV-SC385E, WV-SC384E.

Adobe® Reader® is required to read these operating instructions (PDF) on the provided CD-ROM.

When the Adobe® Reader® is not installed on the PC, download the latest Adobe® Reader® from the Adobe web site and install it.

The model number is abbreviated in some descriptions in this manual.

The screens used in these operating instructions show the case of WV-SC385 (NTSC model).

About notations

The following notations are used when describing the functions limited for specified models.

The functions without the notations are supported by all models.

SW395: The functions with this notation are available when using the model WV-SW395.

SC385: The functions with this notation are available when using the model WV-SC385.

SC384: The functions with this notation are available when using the model WV-SC384.

Trademarks and registered trademarks

- Microsoft, Windows, Windows Vista, Windows Media, Internet Explorer, Active X and DirectX are either registered trademarks or trademarks of Microsoft Corporation in the United States and/or other countries.
- Microsoft product screen shot(s) reprinted with permission from Microsoft Corporation.
- Adobe, the Adobe logo, and Reader are either registered trademarks or trademarks of Adobe Systems Incorporated in the United States and/or other countries.
- QuickTime is a trademark of Apple Inc., registered in the U.S. and other countries.
- SDHC Logo is a trademark of SD-3C, LLC.
- All other trademarks identified herein are the property of their respective owners.

Abbreviations

The following abbreviations are used in these operating instructions.

Microsoft® Windows® 7 Professional (64-bit) and Microsoft® Windows® 7 Professional (32-bit) are described as Windows 7.

Microsoft® Windows Vista® Business SP1 (32-bit) is described as Windows Vista.

Microsoft® Windows® XP Professional SP3 is described as Windows XP.

Windows® Internet Explorer® 8.0, Windows® Internet Explorer® 7.0 and Microsoft® Internet Explorer® 6.0 are described as Internet Explorer.

SDHC/SD memory card is described as SD card or SD memory card.

Universal Plug and Play is described as UPnP™ or UPnP.

Viewer software

It is necessary to install the viewer software "Network Camera View 4S" to display images on a PC. This software can be installed directly from the camera or by double clicking "nwcv4Ssetup.exe" on the CD-ROM provided, and then following the on-screen instructions.

Important:

- The default setting of "Automatic installation of Viewer software" is "On". Follow the instructions on page 139 when the message is displayed on the information bar of the browser.
- When the "Live" page is displayed for the first time, the install wizard of the ActiveX control required to display images from the camera will be displayed. Follow the instructions of the wizard.
- When the install wizard is displayed again even after completing the installation of the ActiveX, restart the PC.
- The viewer software used on each PC should be licensed individually. The number of installations of the viewer software from the camera can be checked on the [Upgrade] tab of the "Maintenance" page (page 122). Refer to your dealer for the software licensing.

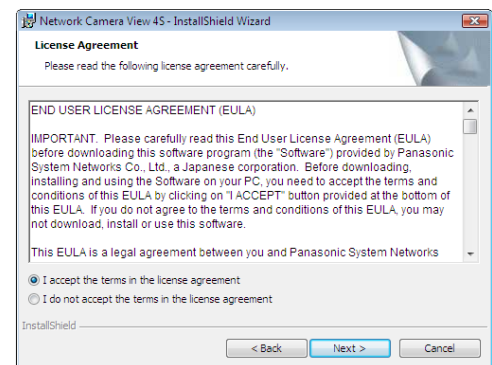

Monitor images on a PC

The following are descriptions of how to monitor images from the camera on a PC.

Monitor images from a single camera

Step 1

Start up the web browser.

Step 2

Enter the IP address designated using the Panasonic IP setup software in the address box of the browser.

Example when entering an IPv4 address:

http://URL registered using IPv4 address
http://192.168.0.10/

Example when entering an IPv6 address:

http://URL registered using IPv6 address
http://[2001:db8::10]/

<Example of IPv4 access>

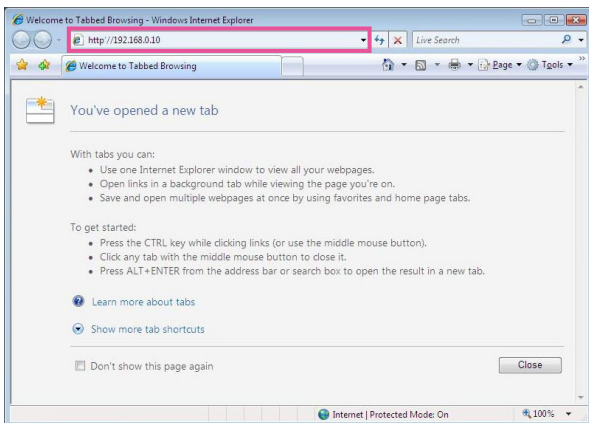

<Example of IPv6 access>

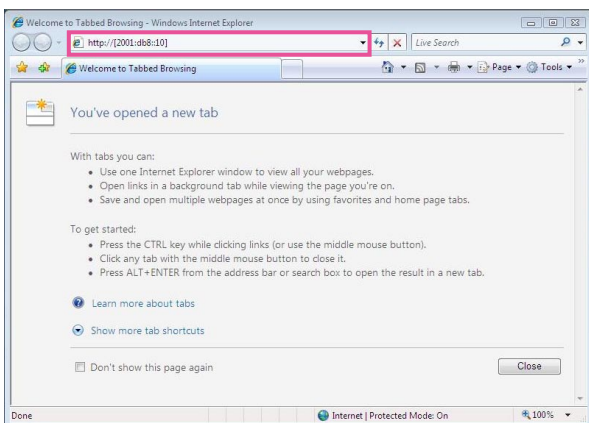

Important:

- When the HTTP port number is changed from "80", enter "http://IP address of the camera + : (colon) + port number" in the address box of the browser. (Example: http://192.168.0.11:8080)
- When the PC is in a local network, configure the proxy server setting of the web browser (under "Internet Options..." under "Tools" of the menu bar) to bypass the proxy server for the local address.

Note:

- Refer to "Access the camera using the HTTPS protocol" (page 106) for further information about the case in which "HTTPS" is selected for "HTTPS" - "Connection" on the [Network] tab of the "Network" page.

Step 3

Press the [Enter] key on the keyboard.

→ The "Live" page will be displayed. Refer to page 8 for further information about the "Live" page.



When "On" is selected for "User auth.", the authentication window will be displayed before displaying live images for the user name and password entries. The default user name and password are as follows.

User name: admin

Password: 12345

Important:

- To enhance the security, change the password for the user name "admin". It is recommended to change this password periodically.
 - When displaying multiple H.264 (or MPEG-4) images on a PC, images may not be displayed depending on the performance of the PC.
-

Note:

- When "H.264" is selected for "Video encoding format", H.264 video will be displayed. When "MPEG-4" is selected, MPEG-4 images will be displayed.
- The maximum number of concurrent access user is 14 including users who is receiving H.264 (or MPEG-4) images and users who are receiving JPEG images. Depending on the set values for "Bandwidth control (bit rate)" and "Max bit rate (per client) **", the maximum concurrent access number may be less than 14 users. When 14 users are concurrently accessing, the access limit message will be displayed for users who subsequently attempt to access. When "Multicast" is selected for "Transmission type" of "H.264" (or "MPEG-4"), only the first user who accessed to monitor H.264 (or MPEG-4) images will be included in the maximum number. The second and subsequent users who are monitoring H.264 (or MPEG-4) images will not be included in the maximum number.
- When "On" is selected for "H.264 transmission" (or "MPEG-4 transmission") (☞ pages 49 and 53), H.264 (or MPEG-4) images will be displayed. When "Off" is selected, a JPEG image will be displayed. It is possible to display a JPEG image even when "On" is selected for "H.264 transmission" (or "MPEG-4 transmission"). In this case, the refresh interval of JPEG images will be limited to 15 fps **SW395** **SC385** and 5 fps **SC384**.
- The refresh interval may become longer depending on a network environment, PC performance, photographic subject, access traffic, etc.

<Refresh interval of JPEG images>

When "On" is selected for "H.264 transmission" (or "MPEG-4 transmission"):

SW395

SC385

10 fps (1280x960,1280x720,800x600)

15 fps (Other image capture sizes)

SC384

5 fps

When "Off" is selected for "H.264 transmission" (or "MPEG-4 transmission"): 30 fps

About the "Live" page

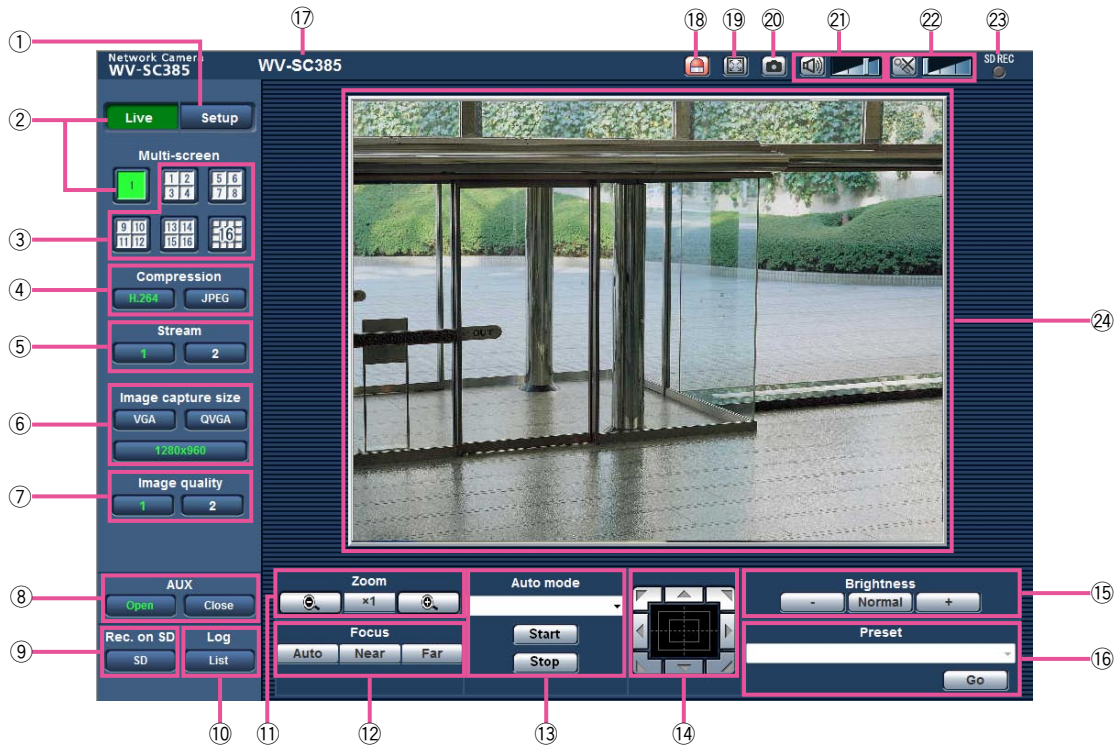

① **[Setup] button (*1)**

Displays the setup menu. The button will turn green and the setup menu will be displayed.

② **[Live] button**

Display the "Live" page. The button will turn green and the "Live" page will be displayed.

③ **[Multi-screen] buttons**

Images from multiple cameras can be displayed on a multi-screen by registering cameras on the setup menu. (☞ Page 13)

④ **[Compression] buttons**

[H.264]/[MPEG-4] button: The letters "H.264" (or "MPEG-4") on the button will turn green and an H.264 (or MPEG-4) image will be displayed. When "On" is selected for "H.264 transmission" (or "MPEG-4 transmission") of "H.264(1)", "H.264(2)" (or "MPEG-4(1)", "MPEG-4(2)"), the [H.264] (or [MPEG-4]) button will be displayed. (☞ Pages 49 and 53)

[JPEG] button: The letters "JPEG" on the button will turn green and JPEG image will be displayed.

⑤ **[Stream] buttons**

These buttons will be displayed only when an H.264 (or MPEG-4) image is displayed.

[1] button: The letter "1" will turn green and images in the main area will be displayed in accordance with the setting of "H.264(1)" (or "MPEG-4(1)"). (☞ Pages 49 and 53)

[2] button: The letter "2" will turn green and images in the main area will be displayed in accordance with the setting of "H.264(2)" (or "MPEG-4(2)"). (☞ Pages 49 and 53)



⑥ **[Image capture size] buttons**

These buttons will be displayed only when a JPEG image is displayed.

[VGA] button: The letters "VGA" will turn green and images in the main area will be displayed in VGA size.

[QVGA] button: The letters "QVGA" will turn green and images in the main area will be displayed in QVGA size.

[1280x960] button: The letters "1280x960" will turn green and images in the main area will be displayed in 1 280 x 960 (pixels).



[800x600] button  : The letters "800x600" will turn green and images in the main area will be displayed in 800 x 600 (pixels).

[640x360] button: The letters "640x360" will turn green and images in the main area will be displayed in 640 x 360 (pixels).

[320x180] button: The letters "320x180" will turn green and images in the main area will be displayed in 320 x 180 (pixels).

[1280x720] button: The letters "1280x720" will turn green and images in the main area will be displayed in 1 280 x 720 (pixels).

Note:

- The buttons [VGA], [QVGA], [1280x960] and [800x600]* are displayed only when "4:3(VGA)" or "4:3(800x600)"* is selected for "Aspect ratio".
*  
- The buttons [640x360], [320x180] and [1280x720] are displayed only when "16:9" is selected for "Aspect ratio".
- When "1280x960" or "1280x720" is selected for the image capture size, it may become smaller than the actual size depending on the window size of the web browser.

⑦ **[Image quality] buttons**

These buttons will be displayed only when a JPEG image is displayed.

[1] button: Images in the main area will be displayed in accordance with the setting for "Quality1" of "Image quality setting".

[2] button: Images in the main area will be displayed in accordance with the setting for "Quality2" of "Image quality setting".

⑧ **[AUX] buttons (*2)**

These buttons will be displayed only when "AUX output" is selected for "Terminal 3" of "Alarm" on the setup menu. (☞ page 75)

[Open] button: The letters "Open" on the button will turn green and the status of AUX connector will be open.

[Close] button: The letters "Close" on the button will turn green and the status of the AUX connector will be closed.

⑨ **[Rec. on SD] button (*2)**

This button will be displayed only when "Manual" is selected for "Save trigger" on the setup menu.

(☞ Page 34)

Click this button to manually record images on the SD memory card. Refer to page 16 for descriptions of how to manually record images on the SD memory card.

⑩ **[Log] button (*1)**

[List] button will become available only when "On" is selected for "Save logs" on the setup menu.

(☞ Page 43)

When this button is clicked, the log list will be displayed and images saved on the SD memory card can be played.

Refer to page 20 for further information about the log list and for how to play images on the SD memory card.

⑪ **[Zoom] buttons (*2)**

: Click this button to adjust the zoom ratio to the "Wide" side.

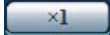
: Click this button to set the zoom ratio to x1.0.

: Click this button to adjust the zoom ratio to the "Tele" side.

⑫ **[Focus] buttons (*2)**

: Click this button to adjust the focus automatically.

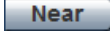
: Click this button to adjust the focus to the "Near" side.

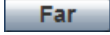
: Click this button to adjust the focus to the "Far" side.

Note:

- When shooting the following place or the following subjects, focus may not be adjusted automatically. Adjust the focus manually.
 - Shiny or strongly reflective subject
 - Subject through the glass with dew or smudge
 - Two subjects whose distances from the camera are different
 - Less contrast subject (e.g. white wall)
 - Horizontal-striped subject such as a window blind
 - Inclined subject
 - Dark subject

⑬ **[Auto mode] (*2)**

Select an operation from the pull-down menu and click the [Start] button. The selected operation will start.

Click the [Stop] button to stop the operation.

The selected operation will stop when the camera (panning/tilting/zooming/focusing) is operated or when an action that is to be taken according to the settings for "Self return" (☞ page 56) or for "Camera action on alarm" (☞ page 76) starts.

Auto track **SW395** **SC385**: Automatically tracks an object in the shooting area.

Note **SW395** **SC385** :

- The auto track function works only when the size of the object is larger than 1/300 of the main area and also the contrast ratio between the object and the background is more than 5 %.
- The auto track function of this camera is the simplified function that tracks a moving object in the shooting area. It may be impossible to track a moving object in the following cases.
 - When there are multiple moving objects in the shooting area
 - When the contrast ratio between a moving object and the background is almost none
 - When an object moves quickly
 - When a moving object is too small or too big
 - When the shooting area is dark
 - When there is a flicker in the shooting area
- When the zoom ratio is set to the TELE side, it may be difficult to obtain accuracy with the auto tracking function. It is recommended to use the auto tracking function with setting the zoom ratio to the "Wide" side.

Auto pan: Automatically pans between the start position and the end position set in advance (☞ page 70).

Even when the camera is operated for zooming or focusing, the camera continues panning. (However, panning will stop when the zoom button (x1) is clicked.)

Preset sequence: Automatically moves to the preset positions (☞ page 67) orderly (start from the lowest preset position number).

360 map-shot: Moves 45° horizontally at a time and repeats 7 times to shoot images of each 45° position (45° x 8 = 360°), and then displays 8 thumbnail images of each 45° position (45° x 8 = 360°) on a newly opened window. When a thumbnail image is clicked, the camera moves to the respective position and live images will be displayed on the "Live" page.

Preset map-shot: Eight thumbnail images of the preset position 1-8 (☞ page 67) will be displayed orderly on a newly displayed window. When a thumbnail image is clicked, the camera moves to the respective position and live images will be displayed on the "Live" page.

Note:

- Do not operate the browser until all the thumbnail images are displayed and the camera returns to the original position (where the camera was when "360 map-shot" or "Preset map-shot" was carried out).
 - When "360 map-shot" is carried out while the camera is moving (panning/tilting), images captured while panning/tilting may be displayed as the thumbnail display. In this case, stop the current operation and carry out "360 map-shot" again.
 - When "Preset map-shot" is carried out with an unregistered preset position (among preset position 1-8), the thumbnail image of the preset position before the unregistered preset position will be displayed. In this case, the camera will not move when the thumbnail image is clicked.
 - The camera will not always return to the exactly same position where it was before "360 map-shot" or "Preset map-shot" was carried out. (It may sometimes be slightly different.)
 - The window on which the thumbnail images are displayed will close when clicking the following buttons that can switch the camera channel or reload images: [Live], [Multi-screen], [H.264], [MPEG-4]/[JPEG], [Stream], [Image capture size] [Image quality], [Setup]. To display the thumbnail images again, carry out "360 map-shot" or "Preset position map-shot" again.
-

⑭ **Control pad/buttons (*2)**

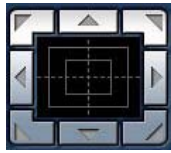

: Left-click on the control pad to adjust the horizontal/vertical position of the camera (panning/tilting). Panning/tilting speed will be faster if a clicked point gets farther from

the center point of the control pad. It is also possible to pan/tilt the camera by dragging the mouse.

Zoom and focus can be adjusted by right-clicking. When an upper/lower area of the control pad is right-clicked, the displayed image will be zoomed in/out on. When a left/right area is right-clicked, the focus will be adjusted to the Near/Far side. Zoom can also be adjusted using the mouse wheel.

⑮ **[Brightness] buttons (*2)**

Available range: 0 - 255

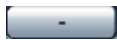

button: The displayed image will be darker.

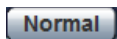

button: The adjusted brightness will return to the default brightness (64).

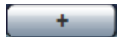

button: Image will be brighter.

⑯ **[Preset] (*2)**

Select a preset position from the pull-down menu and click the [Go] button. The camera will move to the selected preset position (☞ page 67). "H" next to the preset position number indicates the home position. When "Home position" is selected, the camera will move to the home position. (☞ Page 56) When "Preset ID" is registered for a preset position, the registered preset ID will be displayed next to the preset position number.

⑰ **Camera title**

The camera title entered for "Camera title" on the [Basic] tab will be displayed. (☞ Page 30)

⑱ **Alarm occurrence indication button (*2)**

This button will be displayed and will blink when an alarm has occurred. When this button is clicked, the alarm output terminal will be reset and this button will disappear. (☞ Page 17)

⑲ **Full screen button**

Images will be displayed on a full screen. To return to the "Live" page, press the [Esc] key. The aspect ratio of displayed images will be adjusted in accordance with the monitor.

⑳ **Snap shot button**

Click this button to take a picture (a still picture). The picture will be displayed on a newly opened window. When right-clicking on the displayed image, the pop-up menu will be displayed. It is possible to save the image on the PC by selecting "Save" from the displayed pop-up menu. When "Print" is selected, printer output is enabled.

Note:

- The following setting may be necessary when using Microsoft Windows 7 or Microsoft Windows Vista. Click "Internet Options" on the Tools menu of Internet Explorer, and then click the [Security] tab. Select "Trusted sites", and click "Site". Register the camera address on the "Websites" in the "Trusted sites" window.

㉑ **Mic input button (*3)**

Turns on/off the audio reception (hear audio from the camera on a PC). This button will be displayed only when "Mic input", "Interactive(Full-duplex)" or "Interactive(Half-duplex)" is selected for "Audio transmission/reception" on the setup menu.

(☞ Page 72)

When this button is clicked, the button will turn into the  button and audio from the camera will not be heard.

Audio volume can be adjusted (Low/ Middle/ High) by moving the volume cursor .

㉒ **Audio output button (*3)**

Turns on/off the audio transmission (play audio from the PC on the unit speaker). This button will be displayed only when "Audio output", "Interactive(Full-duplex)" or "Interactive(Half-duplex)" is selected for "Audio transmission/reception" on the setup menu.

(☞ Page 72)

The button will blink during the audio transmission. When this button is clicked, the button will turn into the  button and audio from the PC will not be heard.

Audio output volume can be adjusted (Low/Middle/ High) by moving the volume cursor .

Note:

- When a user is using the audio transmission function with "Interactive(Half-duplex)" selected, the receiver button and the transmission button will be inoperable for the other users. When "Interactive(Full-duplex)" is selected, the transmission button is inoperable for other users.
- Possible duration of audio transmission is up to 5 minutes per transmission. When 5 minutes have passed, the audio transmission will automatically stop. To turn the audio transmission function on, click the [Audio output] button again.
- When the camera is restarted, the adjusted volume level (for both the audio transmission and reception) will return to the level that had been set on the [Audio] tab on the setup menu. (☞ Page 73)
- Actual volume level will change in three steps even though the volume cursor can be adjusted minutely.

23 SD recording status indicator

The status of the SD recording can be checked with this indicator.

When the SD recording starts, the SD recording status indicator will light red. It will go off when the SD recording stops.

This indicator will be displayed when "Manual" or "Schedule" is selected for "Save trigger" on the setup menu. (☞ Page 34)

24 Main area (*2)

Images from the camera will be displayed in this area. The current time and date will be displayed according to the settings configured for "Time display format" and "Date/time display format".

(☞ page 29)

In addition, when being adjusted, the status of brightness (☞ page 30), panning/tilting degree and the zoom factor (☞ page 57), and the preset ID (☞ page 68) will be displayed as well as the characters configured for "Camera title on screen" (☞ page 30). The number of lines for the display is 3 when using WV-SW395/WV-SC385, 2 when using WV-SC384.

Click a desired point in the main area on the "Live" page that is to be the center of the angle of view. The camera moves to adjust the position in order to set the clicked point as the center.

When selecting an area in the main area by dragging the mouse, the selected area will be located at the center of the main area. In this case, the zoom ratio will be adjusted automatically.

Zoom can be adjusted using the mouse wheel.

- *1 Only operable by users whose access level is "1. Administrator".
- *2 Only operable by users whose access level is "1. Administrator" or "2. Camera control" when "On" is selected for "User auth." (☞ Page 87).
- *3 Operable by users who belong to the access level selected for "Permission level of audio trans./recep." on the [Audio] tab of the "Image/Audio" page. Refer to page 73 for further information about the "Permission level of audio trans./recep.".

Note:

- When operated by a lower access level user, images displayed on the screen may be changed temporarily. This does not affect operation of the camera.
- When the displayed image is being zoomed in more than 18x, the clicked point may not always be located at the center of the main area.
- When the mouse is dragged to move the camera beyond its operable range, the camera will move to the requested direction and will stop at the end of the operable range. Then, the zoom ratio of the displayed image will automatically be adjusted.
- Depending on the PC in use, screen tearing* may occur when the shooting scene drastically changes due to the GDI restrictions of the OS.

* A phenomenon in which portions of the screen are displayed out of alignment

Monitor images from multiple cameras

Images from multiple cameras can be displayed on a multi-screen. Images from 4 cameras (up to 16 cameras) can be displayed simultaneously. To display images on a multi-screen, it is necessary to register cameras in advance. 4 cameras can be registered as a group and up to 4 groups (16 cameras) can be registered. (Page 74)

Important:

- When displaying images on a 16-screen, panning, tilting and zooming operations become unavailable for images from the Panasonic PTZ cameras.
- When displaying images on a 4-screen, panning, tilting and zooming operations become available only for images from the Panasonic PTZ cameras. Refer to the "Readme" file on the provided CD-ROM for further information about the compatible PTZ cameras and their versions. Or refer to our website (<http://panasonic.net/pss/security/support/info.html>) for further information about the supported software.
- Only JPEG images with frame by frame playback can be displayed on a multi-screen. Audio will not be heard.
- When the power is turned off or the LAN cable is disconnected while displaying images, displaying images on a multi-screen from the "Live" page will become unavailable.
- When displaying the image on a multi-screen and "16:9" is selected for "Aspect ratio", the image will be displayed altered vertically to the aspect ratio of "4:3".

Step 1

Click the desired [Multi-screen] button.

- Images from the registered cameras will be displayed on a selected multi-screen (screen can be split up to 16 areas). The following are instructions when displaying on a 4-split screen.

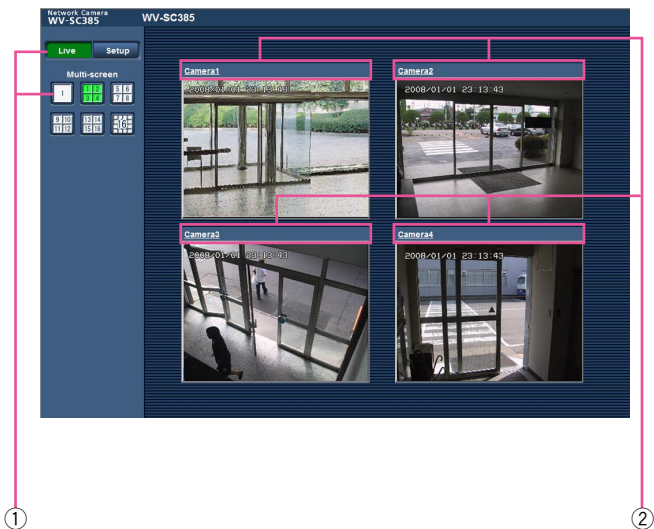

- ① To display images on a single screen, click the [Live] button.
- ② Click a camera title. Live images from the camera corresponding to the clicked camera title will be displayed on the "Live" page of the newly opened window.

Monitor images on a cellular phone

It is possible to connect to the camera using a cellular phone via the Internet and monitor images (JPEG only) from the camera on the screen of the cellular phone. It is also possible to refresh images to display the latest image or perform panning, tilting and zooming operations.

Important:

- When the authentication window is displayed, enter the user name and password. The default user name and password are as follows.
User name: admin
Password: 12345
To enhance the security, change the password for the user "admin". (☞ page 87)
- If the cellular phone in use is not compatible with UTF-8 encode, it is impossible to display the screen correctly.

Note:

- It is necessary to configure the network settings of the cellular phone in advance to connect to the Internet and monitor images from the camera. (☞ Page 93)

Step 1

Access to "http://IP address/mobile"* or "http://Host name registered in the DDNS server/mobile" using a cellular phone.

→ Images from the camera will be displayed.

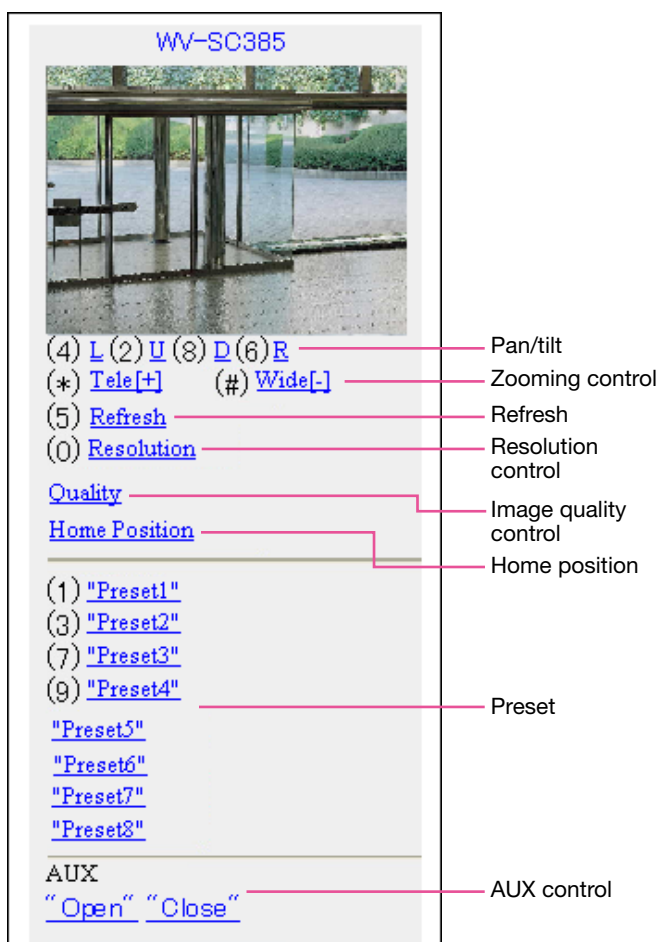

Note:

- When the HTTP port number is changed from "80", enter "http://IP address + : (colon) + port number/mobile"* in the address box of the browser.
- When using the DDNS function, access to "http://Host name registered in the DDNS server + : (colon) + port number/mobile".
- Refer to "Access the camera using the HTTPS protocol" (☞ page 106) for further information about the case in which "HTTPS" is selected for "HTTPS" - "Connection" on the [Network] tab of the "Network" page.
- When the authentication window is displayed, enter the user name of an administrator or user and password. Depending on the cellular phone in use, password entry may be required each time the screen is switched.
- It is impossible to transmit/receive audio using a cellular phone.
- Depending on the cellular phone in use, larger size images may not be displayed. In this case, selecting "Low" for "Image quality setting" of "JPEG" (☞ page 48) may sometimes solve this problem.
- Depending on the cellular phone in use or its contract plan, it may be impossible to access.

* IP address is the global WAN IP address of the router that can be accessed via the Internet.

Functions	Outline of functions
Pan/tilt *	Controls the camera direction. The camera will pan or tilt to each direction by pressing the corresponding dial key.
Zooming control *	It is possible to perform zooming operations of the camera by pressing "*" or "#".
Refresh	Refreshes the camera images by pressing the dial key "5".
Resolution control	Changes the image capture size by pressing the dial key "0".
	* Image in the aspect ratio of "4:3(VGA)" Changes the image capture size between 320x240 (default) and 640x480.
	* Image in the aspect ratio of "4:3(800x600)" Changes the image capture size between 320x240 (default) and 640x480. SW395 SC385
	* Image in the aspect ratio of "16:9" Changes the image capture size between 320x180 (default) and 640x360.
	Note:
	<ul style="list-style-type: none"> Some cellular phones cannot change the image capture size even when resolution is changed by resolution control.
Image quality control	It is possible to change the image quality between "Quality1" and "Quality2" (☞ page 9).
Home position *	The camera will move to the home position. (☞ page 56)
Preset *	The camera will move to the designated preset position to display images by pressing the dial key corresponding to the desired channel. (The dial key numbers are not displayed for Preset No 5 or greater. Only preset IDs will be displayed for them.) (☞ Page 68)
AUX control *	Controls the AUX terminal. These buttons will be displayed only when "AUX output" is selected for "Terminal 3" on the setup menu. (☞ Page 75)

* Only displayed for users whose access level is "1. Administrator" or "2. Camera control" when "On" is selected for "User auth." (☞ page 87)

Record images on the SD memory card manually

Images displayed on the "Live" page can be recorded on the SD memory card manually.

This button is operable only when "Manual" is selected for "Save trigger" on the [SD memory card] tab of the "Basic" page of the setup menu. (☞ page 34)

It is possible to select "JPEG" or "H.264" on "Recording format" of the setup menu. (☞ Page 33) When "JPEG" is selected for "Recording format", still image data are recorded. When "H.264" is selected, video data are recorded. Images recorded on the SD memory card can be copied onto the PC. (☞ Page 38)

Step 1

Display the "Live" page. (☞ Page 6)



Step 2

Click the [SD] button.

→ The SD recording window will open.



Step 3

Click the [Start] button to start recording images on the SD memory card. The SD recording status indicator will light red (☞ Page 9) while images are being recorded on the SD memory card.

The save interval (frame rate) can be configured on the [SD memory card] tab of the "Basic" page. (☞ Page 35)

Step 4

Click the [Stop] button to stop saving images on the SD memory card.

Step 5

Click the [Close] button to close the window.

Note:

- It is possible to obtain image data saved on Drive B by clicking the [Execute] button of "Access img." on the [SD memory card] tab and by logging in the camera to access images from the user authentication window. (☞ page 38)
The destination directory to which data are to be saved will be a fixed directory on Drive B. Refer to the "Directory structure of drive B" section. (☞ page 141)
- When the [Start] button is clicked immediately after the [Stop] button is clicked, saving of images may not start. In this case, click the [Start] button again.

Action at an alarm occurrence

The alarm action (camera action at an alarm occurrence) will be performed when the following alarms occur.

Alarm type

Terminal alarm: When connecting an alarm device such as a sensor to the EXT I/O connector of the camera, the alarm action will be performed when the connected alarm device is activated.

VMD alarm: When motion is detected in the set VMD area, the alarm action will be performed.

* VMD stands for "Video Motion Detection".

Command alarm: When a Panasonic alarm protocol is received from the connected device via a network, the alarm action will be performed.

Action at an alarm occurrence

Display the alarm occurrence indication button on the "Live" page (☞ Page 11)

The alarm occurrence indication button will be displayed on the "Live" page at an alarm occurrence.

Important:

- When "Polling(30s)" is selected for "Alarm status update mode" (☞ page 32), the Alarm occurrence indication button will be refreshed in 30-second intervals. For this reason, it may take a maximum of 30 seconds until the alarm occurrence indication button is displayed on the "Live" page at an alarm occurrence.
-

Notify of alarm occurrences to the device connected to the alarm connector

It is possible to output signals from the alarm connector on the rear of the camera and sound the buzzer when an alarm occurs. The settings for the alarm output can be configured in the "Alarm output terminal setup" section of the [Alarm] tab of the "Alarm" page. (☞ Pages 75 and 79)

Save images on the SD memory card

When an alarm occurs, images (JPEG/H.264) will be saved on the SD memory card. The settings to save images on the SD memory card can be configured on the [SD memory card] tab of the "Basic" page (☞ pages 33 and 34) and the [Alarm] tab of the [Alarm] page (☞ page 77).

Transmit an image onto a server automatically

An alarm image can be transmitted at an alarm occurrence to the server designated in advance. The settings required to transmit an alarm image to a server can be configured in the "Alarm image" section on the [Alarm] tab of the "Alarm" page (☞ page 77) and the [FTP] tab (☞ page 91) of the "Server" page.

Important:

- Select "FTP error" for "Save trigger" on the [SD memory card] tab when using the SD memory card. When "Alarm input" or "Manual" is selected for "Save trigger", an alarm image will not be transmitted at an alarm occurrence to the FTP server.
-

Notify of alarm occurrences by e-mail

Alarm mail (alarm occurrence notification) can be sent at an alarm occurrence to the e-mail addresses registered in advance. Up to 4 addresses can be registered as recipients of the alarm mail. An alarm image (still picture) can be sent with the alarm mail as an attached file. The settings for alarm mail can be configured in the "Mail notification" section on the [Notification] tab of the "Alarm" page (☞ page 83) and the [Mail] tab of the "Server" page (☞ page 90).

Notify of alarm occurrences to the designated IP addresses (Panasonic alarm protocol notification)

This function is available only when a Panasonic device, such as the network disk recorder, is connected to the system. When "On" is selected for "Panasonic alarm protocol", the connected Panasonic device will be notified that the camera is in the alarm state. The settings for Panasonic alarm protocol can be configured in the Panasonic alarm protocol section of the [Notification] tab of the "Alarm" page. (☞ Page 84)

Transmit images onto an FTP server

Images can be transmitted to an FTP server. By configuring the following settings, transmission of images captured at an alarm occurrence or captured at a designated interval to an FTP server will become available.

Important:

- When using this function, set the user name and the password to access the FTP server to restrict users who can log into the FTP server.
 - To transmit images to the FTP server, select "Not use" for "SD memory card", or when "JPEG" is selected for "Recording format", select "FTP error" for "Save trigger" on the [SD memory card] tab of the "Basic" page. (☞ page 33)
-

Transmit an alarm image at an alarm occurrence (Alarm image transmission)

An alarm image can be transmitted at an alarm occurrence to the FTP server. To transmit alarm images to an FTP server, it is necessary to configure the settings in advance.

The settings for the FTP server can be configured on the [FTP] tab of the "Server" page. (☞ Page 91)

The alarm image transmission function can be turned on/off in the "Alarm image" section of the [Alarm] tab of the "Alarm" page. (☞ Page 77)

Note:

- Depending on the network traffic, the number of the transmitted images may not reach the set number of images to be transmitted.
 - Alarm images failed to be transmitted to the FTP server at an alarm occurrence will not be saved on the SD memory card. However, images that failed to transmit to the FTP server using the FTP periodic image transmission function will be saved.
-

Transmit images at a designated interval or period (FTP periodic image transmission)

Images can be transmitted at a designated interval or period. To transmit images at a designated interval or period, it is necessary to configure the settings in advance.

The settings for the FTP server can be configured on the [FTP] tab of the "Server" page. (☞ Page 91)

It is possible to determine whether or not to use the FTP periodic image transmission function and to configure the settings relating to alarm images and the schedule on the [FTP img. trans.] tab of the "Network" page.

(☞ Page 116)

Note:

- Depending on the line speed or the traffic, images may not be transmitted at the designated interval.
 - When "On" is selected for both the alarm image transmission function and the FTP periodic image transmission function, the alarm image transmission function will be given priority over the FTP periodic image transmission function. Therefore, images may not be transmitted at the interval designated on the "FTP periodic image transmission" setting.
-

Save images on the SD memory card when images fail to transmit using the FTP periodic image transmission function

Images that have failed to transmit using the FTP periodic image transmission can be saved automatically on the SD memory card. It is possible to select a trigger to save images on the SD memory card on the [SD memory card] tab of the "Basic" page. (☞ Page 34)

To use the SD memory recording function featured in Panasonic's network disk recorder, select "Off" for "FTP periodic image transmission" (☞ page 117) and "FTP error" for "Save trigger" (☞ page 34).

Important:

- We make no guarantee for any damages of files on the SD memory card incurred by malfunction or error occurrence in files saved in the SD memory card regardless of what the cause may be.

Note:

- When browsing images by selecting an FTP error log on the log list, it is necessary to select "On" for "Save logs". (☞ page 43)
-

Display the log list

The setting items of the cameras will be displayed in list form.

- Alarm log: Logs of the alarm occurrences such as time and date of the alarm occurrences and the alarm type will be displayed.
- Manual/Schedule log: Logs filed when images have been recorded manually or during the period of the schedule on the SD memory card will be displayed.
- FTP trans. error log: Logs filed when the FTP periodic image transmission function has failed will be displayed.

Each log list can be displayed only when "On" is selected for "Save logs" on the [Log] tab of the "Basic" page (☞ page 43) respectively.

Step 1

Display the "Live" page. (☞ Page 6)



Step 2

Click the [List] button.

→ The log list will be displayed in a newly opened window (log list window).

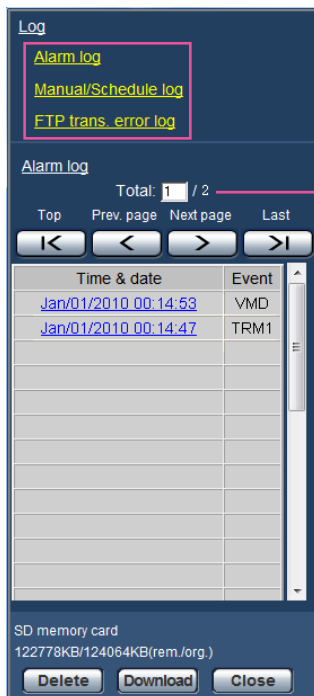

Number of the listed logs

Important:

- Only a single user can operate the log list window. Other users cannot access the log list window.

Note:

- When "Not use" is selected for "SD memory card", the "Manual/Schedule log" list and the "FTP trans. error log" list will not be displayed.
- When "H.264" is selected for "Recording format" of the SD memory card, the "FTP trans. error log" list will not be displayed.

Step 3

Click the desired log type listed below "Log" to display the log list.

→ The log list of the selected log type will be displayed.

Note:

- When any images are saved on the SD memory card, the image can be displayed by clicking Time and Date when "JPEG" is selected for "Recording format" of the setup menu. (☞ Page 33)

About the log list window

Number of the listed logs

Total number of the logs of the selected log type and a number of the log being displayed on the top of the log list will be displayed.

Note:

- Enter the desired log number and press the [Enter] key on the keyboard. The log of the designated number will be displayed on the top of the log list.

[Top] button

Click this button to display the log listed at the top.

[Prev. page] button

Click this button to display the previous page of the log list.

Note:

- When the mouse button is held down while placing the mouse pointer on the [Prev. page] button, the displayed log number will be decremented. When the mouse button is released, the decrement of the log number will stop and the log number displayed at the moment when the mouse button is released will be the top of the currently displayed page.
-

[Next page] button

Click this button to display the next page of the log list.

Note:

- When the mouse button is held down while placing the mouse pointer on the [Next page] button, the displayed log number will be incremented. When the mouse button is released, the increment of the log number will stop and the log number displayed at the moment when the mouse button is released will be the top of the currently displayed page.
-

[Last] button

Click this button to display the log listed at the bottom.

[Time & date]

Time and date when each log has been filed will be displayed.

Note:

- When "Off" is selected for "Time display format" (☞ page 30), time and date of alarm occurrence will be displayed in 24-hour format.
 - The recording timing of logs is as follows.
 - Alarm log:** Alarm occurrence time and date will be filed as a log.
 - Manual/Schedule log:** Time and date when recording of images onto the SD memory card started manually or during the period of the schedule will be filed as a log. When JPEG images are recorded sequentially, logs will be filed every one hour.
 - FTP trans. error log:** Logs will be filed every one hour.
-

[Event]

The event type will be displayed. The event types will be displayed only when displaying the alarm log list.

TRM1: Alarm by alarm input to Terminal 1

TRM2: Alarm by alarm input to Terminal 2

TRM3: Alarm by alarm input to Terminal 3

VMD: Alarm by VMD alarm

COM: Alarm by command alarm

[SD memory card]

Available capacity and the original capacity of the SD memory card will be displayed.

The displayed descriptions are the same descriptions displayed as "Remaining capacity" on the [SD memory card] tab. (☞ Page 36)

[Delete] button

Click this button to delete the currently displayed log list.

When using the SD memory card, images associated with the log list will also be deleted.

Important:

- If there are too many recorded data files, it may take time to delete all of them. (When the total size of the JPEG files is 1 GB, it may require around 1 hour.) Formatting the SD memory card can shorten the time to delete all the data. (☞ Page 36)
 - In the process of the deletion, only logs will be saved, and it is impossible to save images newly.
 - Do not turn off the power of the camera until the deletion is complete.
 - When the power of the camera is turned off in the process of the deletion, some images may remain on the SD memory card.
 - In this case, click the [Delete] button on the same log list window used to delete the logs.
-

[Download] button

Click this button to download all logs of the selected log list as a file onto the PC.

[Close] button

Click this button to close the log list window.

Playback of images on the SD memory card

When clicking a time and date listed on the log list window, the "Live" page will turn to the "Playback" page. When images associated with the clicked time and date are on the SD memory card, the first image of them will be displayed.

Important:

- This function is available only when "JPEG" is selected for "Recording format" of the SD memory card. When "H.264" is selected, the "Playback" page will not be displayed. However, images can be downloaded. Refer to page 24 for descriptions of how to operate.
- Refresh interval of images may become slow during playback or download.
- When many images are saved on the SD memory card, it may take time to display images on the "Playback" page.
- Even when the size of the images saved on the SD memory card is "QVGA", "800x600"* or "1280x960", the images will be played back in VGA size on the playback page. When "16:9" is selected for the "Aspect ratio", images will be displayed in an image capture size of "640x360", even "320x180" or "1280x720" is selected. Therefore, images may look coarse on the "Playback" window.
* SW395 SC385
- When playing images by selecting an FTP error log on the log list, images may not be played in order of images recorded on the SD memory card if they have been recorded on the SD memory card with selected value for the "Transmission interval" setting on the [FTP img. trans.] tab is "1 min" or less.

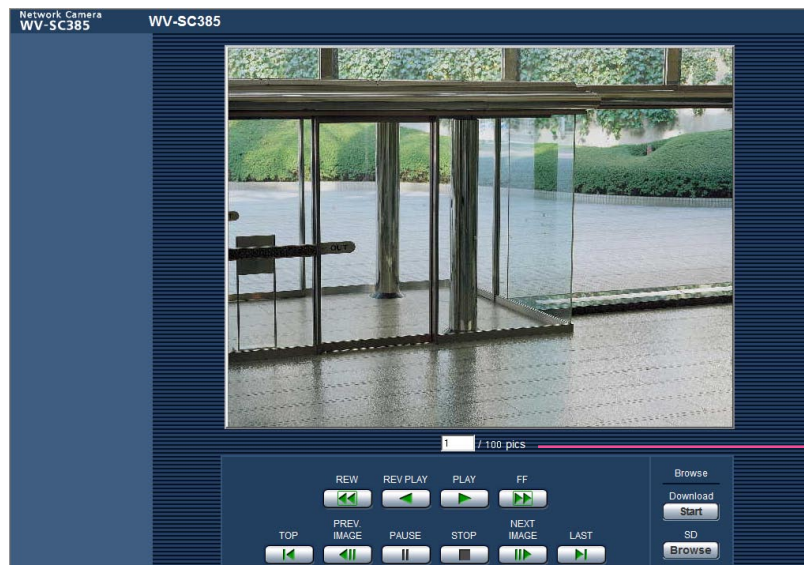

About the playback page

Number of images

When clicking a time and date listed on the log list window, total number of images associated with the clicked time and date, and the number of the currently displayed image will be displayed.

Note:

- Enter the desired number of image and press the [Enter] key on the keyboard. The image of the designated number will be displayed.

[REW] button

Each time the button is clicked, the playback speed will change.

When the [PLAY] button or the [REV PLAY] button is clicked during fast playback/fast reverse playback, playback speed will return to the normal playback speed.

[REV PLAY] button

Images will be played in reverse sequential order.

[PLAY] button

When this button is clicked, images will be played in sequential order.

[FF] button

Each time the button is clicked, the playback speed will change.

When the [PLAY] button or the [REV PLAY] button is clicked during fast playback/fast reverse playback, playback speed will return to the normal playback speed.

[TOP] button

The first image will be displayed.

[PREV IMAGE] button

The previous frame will be displayed and paused when this button is clicked during playback.

Each time this button is clicked during pausing, the frame previous to the currently displayed frame will be displayed.

Note:

- When the mouse button is held down while the mouse pointer is on this button, the image number will be decremented. When the mouse button is released, the decrementing of the image number will stop and the image corresponding to the currently displayed number will be displayed.
-

[PAUSE] button

Playback will be paused when this button is clicked during playback.

Playback will resume when this button is clicked during pausing.

[STOP] button

Playback will stop and the "Playback" window will turn to the "Live" page.

[NEXT IMAGE] button

The next frame will be displayed and paused when this button is clicked during playback.

Each time this button is clicked during pausing, the frame next to the currently displayed frame will be displayed.

Note:

- When the mouse button is held down while the mouse pointer is on this button, the image number will be incremented.

When the mouse button is released, the increment of the image number will stop and the image number displayed at the moment when the mouse button is released will be displayed.

[LAST] button

The last image will be displayed.

■ SD card**[Start] button**

The selected image will be downloaded onto the PC. Before downloading images, designate the destination directory in advance. (☞ Page 43) The following window will be displayed when the [Start] button is clicked. Select the image to be downloaded, and then click the [OK] button.

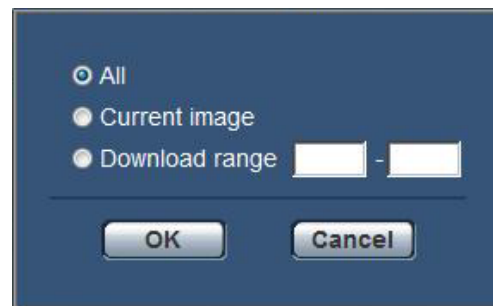

All: All images saved at the selected time and date will be downloaded.

Current image: Only the currently displayed image will be downloaded.

Download range: Images in the designated range of number of images will be downloaded.

Note:

- When the [Cancel] button is clicked in the process of the download, the download will be canceled. In this case, images already downloaded before clicking the [Cancel] button will be saved on the PC.
-

[Browse] button

When successfully logged in after the user authentication process, a folder on the SD memory card in which images are saved will be displayed. (☞ Page 38)

Download the images (When "H.264" is selected for "Recording format" of the SD memory card)

Important:

- Depending on the network environment, download of video data may fail.

To play back video data recorded on the SD memory card, download the desired data, and save the data on the PC. It is impossible to play back video data on the "Playback" page. For this reason, follow the procedure below.

Step 1

Click the time & date on the log list window.
(☞ Page 20)

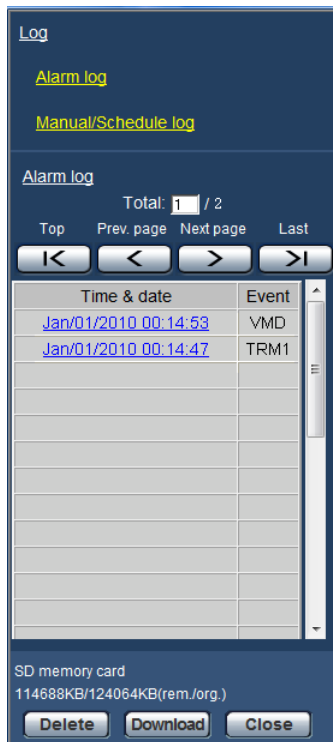

→ The message window will be displayed to ask if it is OK to start download.

Step 2

Select the image to be downloaded, and then click the [OK] button.

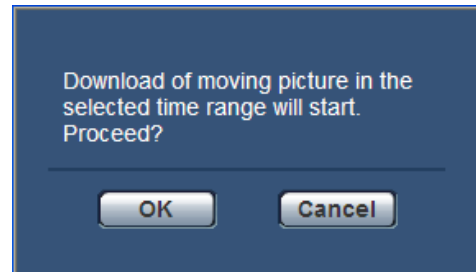

→ Image saved at the clicked time and date will be downloaded.

Note:

- When the [Cancel] button is clicked in the process of the download, the download will be canceled. In this case, images already downloaded before clicking the [Cancel] button will be saved on the PC.
 - Downloading of the associated video data will be started. Before downloading images, designate the destination directory in advance. (☞ Page 43)
 - * When the [Cancel] button is clicked after the download is started, it may take time to cancel the download.
 - * Video data are saved in the files of approx. 2 MB. When the file size of video data is more than 2 MB, two or more files will be downloaded.
- It is possible to play back video data saved on the PC using such applications as QuickTime® Player or Windows Media® Player*1. However, we are not liable for performance relating to these applications.
- *1 The supported operating system is Microsoft® Windows® 7 only.
- Depending on the status of the SD memory card, QuickTime Player, or Windows Media Player, video data cannot be played back.

About the network security

Equipped security functions

The following security functions are featured in this camera.

- ① Access restrictions by the host authentication and the user authentication
It is possible to restrict users from accessing the camera by setting the host authentication and/or the user authentication to "On". (☞ Pages 87 and 88)
- ② Access restrictions by changing the HTTP port
It is possible to prevent illegal access such as port scanning, etc. by changing the HTTP port number. (☞ Page 94)
- ③ Access encryption by the HTTPS function
It is possible to enhance the network security by encrypting the access to cameras using the HTTPS function. (☞ Page 99)

Important:

- Design and enhance security countermeasures to prevent leakage of information such as image data, authentication information (user name and password), alarm mail information, FTP server information, DDNS server information, etc. Perform the countermeasure such as access restriction (using the user authentication) or access encryption (using the HTTPS function).
 - After the camera is accessed by the administrator, make sure to close the browser for added security.
 - Change the administrator password periodically for added security.
-

Note:

- When user authentication (authentication error) has failed to pass 8 times within 30 seconds using the same IP address (PC), access to the camera will be denied for a while.
-

Display the setup menu from a PC

The settings of the camera can be configured on the setup menu.

Important:

- The setup menu is only operable by users whose access level is "1. Administrator". Refer to page 87 for how to configure the access level.

How to display the setup menu

Step 1

Display the "Live" page. (Page 6)

Step 2

Click the [Setup] button on the "Live" page.

→ The window with the user name and password entry fields will be displayed.

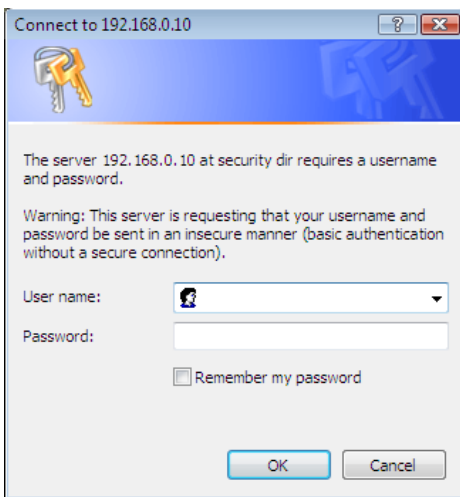

Step 3

Click the [OK] button after entering the user name and the password.

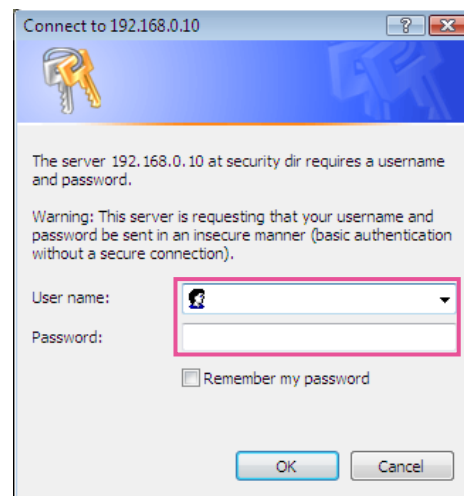

→ The setup menu will be displayed.
Refer to page 28 for further information about this menu.

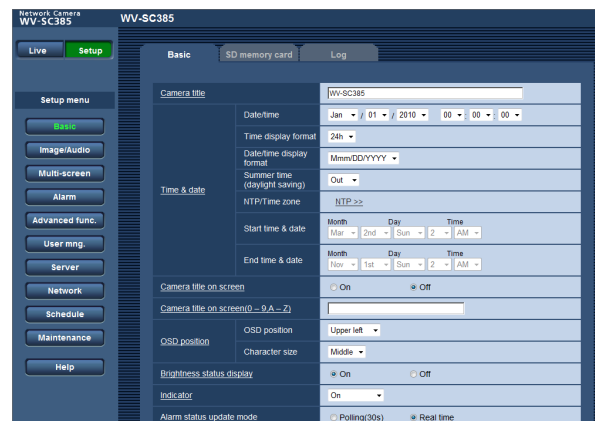

How to operate the setup menu

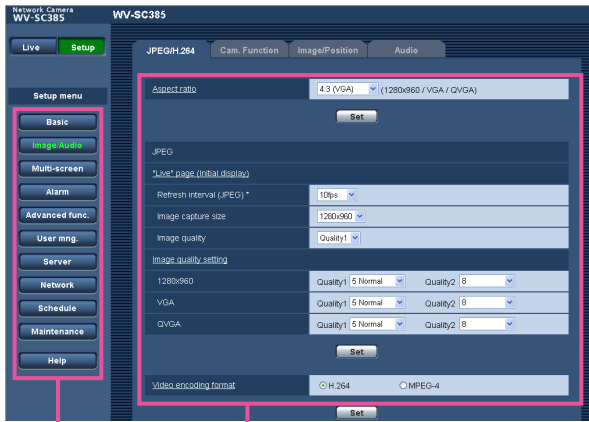

Menu buttons

Setup page

Step 1

Click the desired button in the frame on the left of the window to display the respective setup menu. When there are tabs at the top of the setup page displayed in the frame on the right of the window, click the desired tab to display and configure the setting items relating to the name of the tab.

Step 2

Complete each setting item displayed in the frame on the right of the window.

Step 3

After completing each setting item, click the [Set] button to apply them.

Important:

- When there are two or more [Set] and [Execute] buttons on the page, click the respective button to the edited setting item.

<Example>

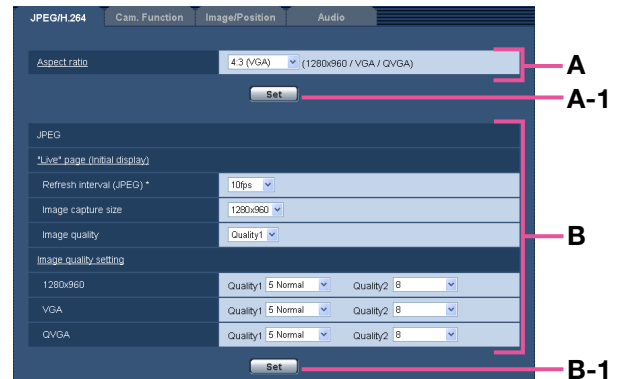

When completing the setting items in field A, click the [Set] button (A-1) below field (A).

The edited settings in field A will not be applied unless the [Set] button (A-1) below field (A) is clicked.

In the same manner as above, click the [Set] button (B-1) below field B when completing the setting items in field B.

About the setup menu window

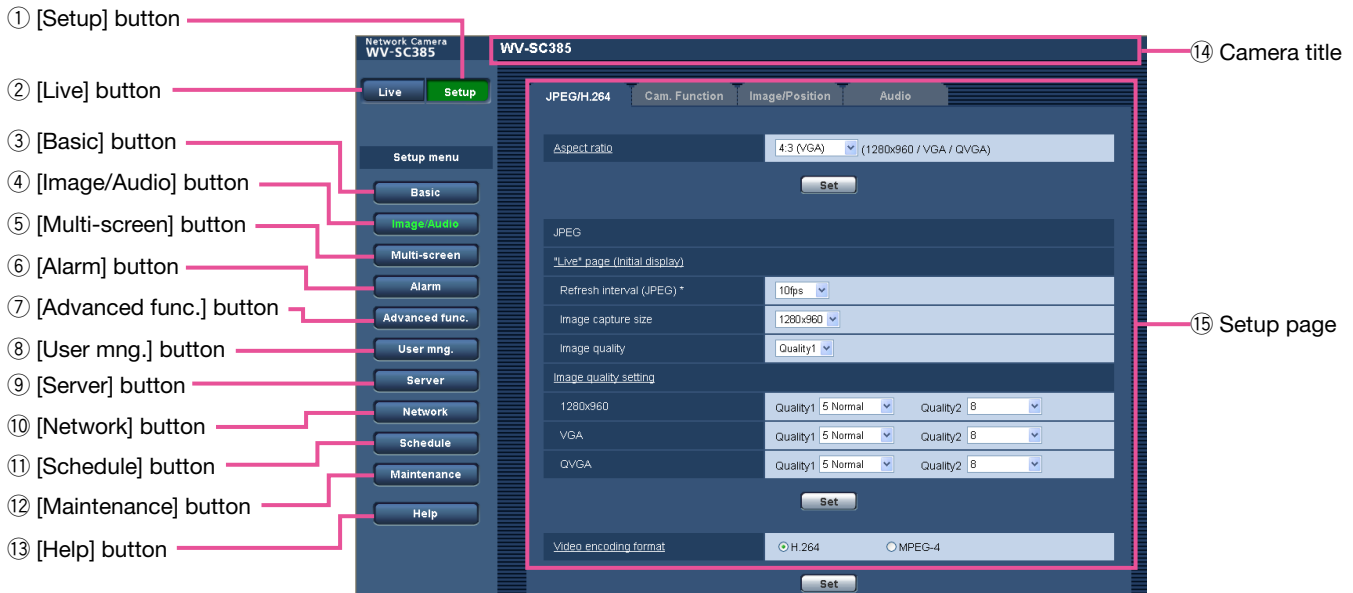

① **[Setup] button**
Display the "Setup" page.

② **[Live] button**
Display the "Live" page.

③ **[Basic] button**
Displays the "Basic" page. The basic settings such as time and date and camera title, and the settings relating to the SD memory card can be configured on the "Basic" page. (☞ Page 30)

④ **[Image/Audio] button**
Displays the "Image/Audio" page. The settings relating to image quality, image capture size and camera actions of JPEG/H.264 (or MPEG-4) camera images can be configured on the "Image/Audio" page. (☞ Page 47)

⑤ **[Multi-screen] button**
Displays the "Multi-screen" page. The cameras from which images are to be displayed on a multi-screen can be registered on the "Multi-screen" page. (☞ Page 74)

⑥ **[Alarm] button**
Displays the "Alarm" page. The settings relating to alarm occurrences such as settings for the alarm action at an alarm occurrence, the alarm occurrence notification, and the VMD area settings can be configured on the "Alarm" page. (☞ Page 75)

⑦ **[Advanced func.] button**
Displays the "Advanced func." page. The setting relating to the XML notification, destinations of information about the face detection and the settings relating to the face detection can be configured on the "Advanced func." page. (☞ Page 85)

⑧ **[User mng.] button**
Displays the "User mng." page. The settings relating to the authentication such as users and PCs restrictions for accessing the camera can be configured on the "User mng." page. (☞ Page 87)

⑨ **[Server] button**
Displays the "Server" page. The settings relating to the mail server, the FTP server and the NTP server to which the camera accesses can be configured on the "Server" page. (☞ Page 90)

⑩ **[Network] button**

Displays the "Network" page. The network settings and the settings relating to DDNS (Dynamic DNS), SNMP (Simple Network Management Protocol) and the FTP (File Transfer Protocol) periodic transmission can be configured on the "Network" page. (☞ Page 93)

⑪ **[Schedule] button**

Displays the "Schedule" page. On the "Schedule" page, it is possible to designate time zones to allow to receive alarm input or to allow to activate the VMD detection function. (☞ Page 120)

⑫ **[Maintenance] button**

Displays the "Maintenance" page. System log check, firmware upgrade, status check and initialization of the setup menu can be carried out on the "Maintenance" page. (☞ Page 121)

⑬ **[Help] button**

Displays the "Help" page. (☞ Page 126)

⑭ **Camera title**

The title of the camera whose settings are currently being configured will be displayed.

⑮ **Setup page**

Pages of each setup menu will be displayed. There are tabs for some setup menus. When the underlined item is clicked, the corresponding help page will be displayed.

Configure the basic settings of the camera [Basic]

The basic settings such as camera title, time and date, SD memory card and the logs can be configured on the "Basic" page.

The "Basic" page has 3 tabs; the [Basic] tab, the [SD memory card] tab and the [Log] tab.

Configure the basic settings [Basic]

Click the [Basic] tab on the "Basic" page. (☞ Pages 26 and 27: How to display/operate the setup menu)

The settings such as the camera title, time and date, etc. can be configured on this page.

[Camera title]

Enter the title of the camera. Click the [Set] button after entering the title of the camera. The entered title will be displayed in the "Camera title" field.

Available number of characters: 0 - 20 characters

Unavailable characters: "&"

Default: Varies as follows depending on the model in use.

WV-SC384

WV-SC385

WV-SW395

[Date/time]

Enter the current time and date. When "12h" is selected for "Time display format", "AM" or "PM" can be selected.

Available range: 01/01/2010 00:00:00 - 31/12/2035 23:59:59

Important:

- Depending on the conditions such as the ambient temperature and operating period, the configured time & date may not be accurate.

- Use an NTP server when the more accurate time & date setting is required for the system operation. (☞ Page 92)

[Time display format]

Select the time display format from "24h", "12h" and "Off". Enter the current hour reflecting this setting when entering the current time and date for "Date/time". To hide time and date, select "Off".

Default: 24h

[Date/time display format]

Select a date/time display format. When "2010/04/01 13:10:00" is set for "Date/time" after selecting "24h" for "Date/time display format", time & date will be respectively displayed as follows.

DD/MM/YYYY: 01/04/2010 13:10:00

MM/DD/YYYY: 04/01/2010 13:10:00

DD/Mmm/YYYY: 01/Apr/2010 13:10:00

YYYY/MM/DD: 2010/04/01 13:10:00

Mmm/DD/YYYY: Apr/01/2010 13:10:00

Default: DD/MM/YYYY (PAL model)

Mmm/DD/YYYY (NTSC model)

[Summer time (daylight saving)]

Select "In", "Out" or "Auto" to determine whether or not to apply daylight saving time. Configure this setting if the summer time (daylight saving time) is applied in the location where the camera is in use.

In: Applies summer time. An asterisk (*) will be displayed on the left side of the displayed time and date.

Out: Does not apply summer time.

Auto: Applies summer time in accordance with the settings for "Start time & date" and "End time & date" (month, week, day of the week, time).

Default: Out

[NTP/Time zone]

When "NTP" is clicked, the [NTP] tab of the "Server" page will be displayed. (☞ Page 92)

[Start time & date][End time & date]

When "Auto" is selected for "Summer time(daylight saving)", select the time & date for the start time and the date time (month, week, day of the week, time).

[Camera title on screen]

Select "On" or "Off" to determine whether or not to display the camera title on the screen.

When "On" is selected, the character string entered for "Camera title on screen (0-9, A-Z)" will be displayed at the position selected for "OSD position".

Default: Off

Note **SC384** :

- When moving the camera to a preset position, the characters configured for "Camera title on screen" will be deleted, and the preset ID will be displayed instead.

[Camera title on screen (0-9, A-Z)]

Enter a character string to be displayed on the image.

Available number of characters: 0 - 20 characters

Available characters: 0-9, A-Z and the following marks.

!"# \$% &'()*+,-./:; =?

Default: None (blank)

[OSD position]

Select the position where the time and date and a character string to be displayed on the image of the "Live" page.

Upper left: The above information will be displayed at the upper left corner of the main area on the "Live" page.

Lower left: The above information will be displayed at the lower left corner of the main area on the "Live" page.

Upper right: The above information will be displayed at the upper right corner of the main area on the "Live" page.

Lower right: The above information will be displayed at the lower right corner of the main area on the "Live" page.

Default: Upper left

[Character size] **SW395** **SC385**

Select the size of the entered character string to be displayed at the selected OSD position in the screen of the "Live" page.

Large: The character size will become large size.

Middle: The character size will become standard size.

Small: The character size will become small size.

Default: Middle

Note:

- "Small" will be set for WV-SC384, WV-SC384E.

[Brightness status display]

Select "On" or "Off" to determine whether or not to display the status of brightness on images displayed on the "Live" page when adjusting brightness.

Default: On

[Indicator]

Determine whether or not to use the following indicators.

- Link indicator
- Access indicator
- Live indicator

On: All the indicators will light in accordance with the status.

On(Access): Only the live indicator will light when images are viewed.

Off: All the indicators will light off.

Default: On

Note:

- **Link indicator (orange):** This indicator will light when communication with the connected device is available.
- **Access indicator (green):** This indicator will light when accessing a network.
- **Live indicator (Red/Orange/Green):** The live indicator will light or blink as follows depending on the camera status.

Operation status		Indicator status
When the power is turned on	Before the network connection is established	Blinks orange
	When the network connection is established	Blinks orange → Blinks green → Lights green
During the standby or connection (Cable is not connected.)		Lights orange
During standby or connection (Cable is connected.)		Lights green
During the upgrade process		Blinks orange
During the initialization		Blinks orange → Lights off
Port forwarding error caused by the UPnP function		Blinks orange (in 2 seconds intervals (on for 1 second / off for 1 second))
Trouble happening on the camera		Blinks red
Failure in writing data on the SDHC/SD memory card		Lights red

[Alarm status update mode]

Select an interval of the camera status notification from the following.

When the status of the camera changes, the alarm occurrence indication button, the [AUX] button or the SD saving status indicator will be displayed to notify of the camera status.

Polling(30s): Updates the status each 30 seconds and provide notification of the camera status.

Real time: Provide notification of the camera status when the status has changed.

Default: Real time

Note:

- Depending on the network environment, notification may not be provided in real time.
-

[Alarm status reception port]

When selecting "Real time" for "Alarm status update mode", designate a port number to which the status change notification is to be sent.

Available port number: 1 - 65535

Unavailable port number: Refer to the help window.

Default: 31004

[Automatic installation of viewer software]

Determine whether or not to install the viewer software from this camera.

On: Installs the viewer software from the camera automatically.

Off: The viewer software cannot be installed from the camera.

Default: On

Important:

- It is impossible to display images and to receive/transmit audio between the camera and the PC when the viewer software "Network Camera View 4S" is not installed on the PC.
 - The number of the viewer software installations can be checked on the [Upgrade] tab of the "Maintenance" page.
-

Configure the settings relating to the SD memory card [SD memory card]

Click the [SD memory card] tab on the "Basic" page. (☞ Pages 26 and 27: How to display/operate the setup menu)
The settings relating to the SD memory card can be configured on this page.

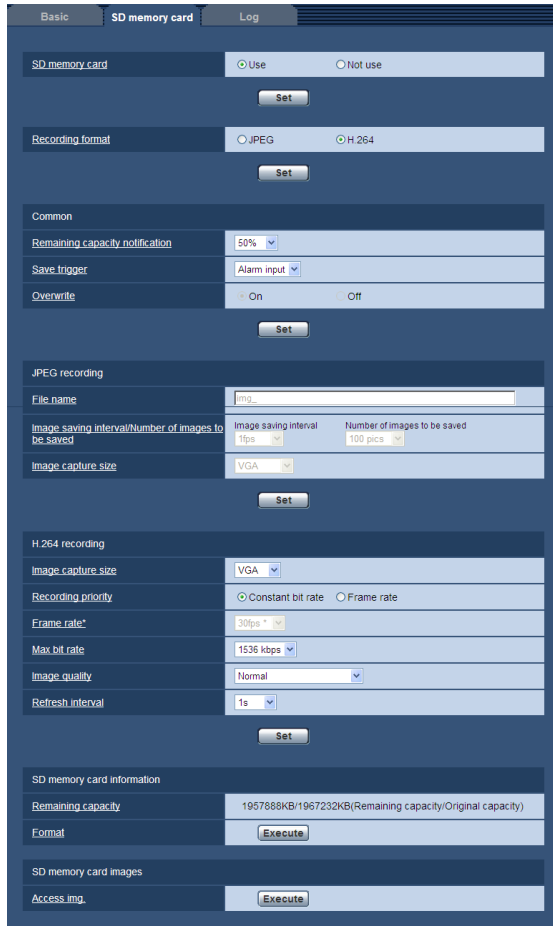

■ SD memory card

[SD memory card]

Select "Use" or "Not use" to determine whether or not to use the SD memory card.

Default: Use

Important:

- Select "Not use" when operating without a SD memory card.
- When the setting is changed between "Use" and "Not use" while another user is during operation, the operation will be canceled.
- Before removing the SD memory card from the camera, it is necessary to select "Not use" first.
- After inserting the SD memory card, it is necessary to select "Use" to use the SD memory card.

- When playing or downloading images saved on the SD memory card, it is necessary to select "On" for "Save logs" on the [Log] tab (☞ page 43) in advance.
- When the image refresh interval is short, notification/recording timing or interval may become incorrect. Notification/recording may also not be performed correctly as configured when multiple users are receiving images. In this case, set the refresh interval longer.
- There are limited times to overwrite on an SD memory card. When having a high frequency of overwriting, the lifetime of the SD memory card may become shorter.
- A lifetime of a SD memory card should be influenced by the number of the image files stored and log savings on the SD memory card. Selecting H.264 for "Recording format" can reduce the number of files to be stored on the SD memory card.
- The data writing speed will go down after data are repeatedly written down on an SD memory card.

[Recording format]

Select "JPEG" or "H.264" for the video encoding format of image data to be recorded on the SD memory card.

JPEG: Records still image data.

H.264: Records video data in the MP4 video encoding format. Audio will not be recorded.

Default: JPEG

Note:

- When "H.264" is selected, it will become impossible to transmit images with the settings of MPEG-4 or H.264(2).
- When "H.264" is selected, the settings for "H.264(2)" on the [JPEG/H.264] tab of the "Image/Audio" page will be changed to the settings for "H.264 recording".
- When the setting value of "Video encoding format" on the [JPEG/H.264] tab of the "Image/Audio" page is changed from "H.264" to "MPEG-4", the setting value of "Recording format" will automatically be changed to "JPEG".

- When "H.264" is selected, the priority band may not be maintained if "H.264/MPEG-4(2)" is selected for "Priority stream" - "Stream type" on the [System] tab of the "User mng." page.
- When using the SD memory recording function of a Panasonic's network disk recorder, select "JPEG" for "Recording format".
- When the setting of "Recording format" is changed between "JPEG" and "H.264", format the SD memory card. (☞ Page 36)
- Due to the difference in file formats, the indication of remaining capacity of the SD memory card differs between the cases when "JPEG" is selected and when "H.264" is selected for "Recording format".
- When "H.264" is selected for "Recording format", the following settings in "H.264 recording"; "Image capture size", "Frame rate", "Max bit rate", "Image quality", and "Refresh interval" will be read from the settings in "H.264(2)". When "2s", "3s", "4s" or "5s" is selected for "Refresh interval" of "H.264(2)", "Refresh interval" for "H.264 recording" will be set to "1s" after changing "Recording format" to "H.264".
- When the setting value of "Recording format" is changed to "H.264", the setting value of "Save logs" on the [Log] tab (☞ page 43) of the "Basic" page will automatically be changed.
- When the setting value of "Recording format" is changed to "H.264", the setting value of "Save logs" on the [Log] tab (☞ page 43) of the "Basic" page will automatically be changed.
- When "H.264" is selected for "Recording format", alarm images are saved in accordance with the settings of "Pre alarm" and "Post alarm (Recording) duration" on the [Alarm] tab of the "Alarm" page.
- When "H.264" is selected for "Recording format", the name of the saved file will be given automatically.

■ Common

[Remaining capacity notification]

When the mail notification function or the Panasonic alarm protocol function is used to provide notification of the remaining capacity of the SD memory card, select a level to be notified at from the following.

50%/ 20%/ 10%/ 5%/ 2%

Default: 50%

Note:

- Notification will be provided each time the remaining capacity of the SD memory card reached the values above.

For example, notification will be provided each time the remaining capacity reaches 50%, 20%, 10%, 5% and 2% when "50%" is selected. Notification may not always be made at the very moment when the remaining capacity of the SD memory card has reached each value.

[Save trigger]

Select a trigger to save images on the SD memory card from the following.

FTP error: Saves images when images have failed to transmit to the FTP server by the FTP periodic image transmission function. (Available only for JPEG images)

Alarm input: Saves images at an alarm occurrence.

Manual: Saves images manually.

Schedule: Saves images in accordance with the settings for "Schedule" (☞ page 120). (Available only for H.264 images)

Default: FTP error

Note:

- When "H.264" is selected for "Recording format", "FTP error" is unavailable.
- Select "FTP error" when images are to be transmitted to the FTP server at an alarm occurrence.
- When "JPEG" is selected for "Recording format", "Schedule" is unavailable.

[Overwrite]

Determine whether or not to overwrite when the remaining capacity of the SD memory card becomes insufficient.

This setting is available only when "Manual" or "Schedule" is selected for "Save trigger".

On: Overwrites when the remaining capacity of the SD memory card becomes insufficient. (The oldest image is the first to be overwritten.)

Off: Stops saving images on the SD memory card when the SD memory card becomes full.

Default: Off

Note:

The overwrite setting will be as follows according to the "Save trigger" setting.

FTP error: Will not be overwritten.

Alarm input: Will be overwritten.

Manual, Schedule: Can be determined by selecting "On" or "Off" for "Overwrite".

■ JPEG recording

This setting is available only when "JPEG" is selected for "Recording format" of the SD memory card.

[File name]

Enter the file name used for the image to be saved on the SD memory card. The file name will be as follows.

File name: ["Entered file name" + "Time and date (year/ month/ day/ hour/ minute/ second)"] + "Serial number"

Available number of characters: 1 - 8 characters

Note:

- When "H.264" is selected for "Recording format", the name of the saved file will be given automatically.
- When "FTP error" is selected for "Save trigger", the file name entered for "File name" on the [FTP img. trans.] tab of the "Network" page will be used for the file name of the image saved on the SD memory card.

[Image saving interval/Number of images to be saved - Image saving interval]

When "Alarm input" or "Manual" is selected for "Save trigger", select an interval (frame rate) of saving images on the SD memory card from the following.

0.1fps/ 0.2fps/ 0.33fps/ 0.5fps/ 1fps

Default: 1fps

[Image saving interval/Number of images to be saved - Number of images to be saved]

Select a number of alarm images to be saved on the SD memory card from the following.

10pics/ 20pics/ 30pics/ 50pics/ 100pics/ 200pics/ 300pics/ 500pics/ 1000pics/ 2000pics/ 3000pics

Default: 100pics

Note:

- When "H.264" is selected for "Recording format", Pre alarm and Post alarm can be set on "H.264 recording" of [Alarm] tab.
- "Number of images to be saved" can be configured only when "Alarm input" is selected for "Save trigger".

[Image capture size]

When "Manual" is selected for "Save trigger" and "JPEG" is selected for "Recording format", select the image capture size of the images to be saved on the SD memory card from the following.

When "4:3(VGA)" is selected for "Aspect ratio"

QVGA/ VGA/ 1280x960

When "4:3(800x600)" is selected for "Aspect ratio"

SW395 **SC385**

QVGA/ 800x600/ 1280x960

When "16:9" is selected for "Aspect ratio"

320x180/ 640x360/ 1280x720

Default: VGA

Note:

- When "FTP error" is selected for "Save trigger", images will be saved with the image capture size selected on the [FTP img. trans.] tab of the "Network" page.
- When "H.264" is selected for "Recording format", select the image capture size for "H.264 recording" - "Image capture size" on the [SD memory card] tab.
- When "Alarm input" is selected for "Save trigger", images will be saved with the image capture size selected on the [Alarm] tab of the "Alarm" page.

■ H.264 recording

This setting is available only when "H.264" is selected for "Recording format" of the SD memory card.

When the second [Set] button on the setup page is clicked, the settings for "H.264 recording" will be displayed on the bottom of the tab.

[Image capture size]

Select the image capture size from the following.

When "4:3(VGA)" is selected for "Aspect ratio"

QVGA/ VGA **SC384**

QVGA/ VGA/ 1280x960 **SW395** **SC385**

When "4:3(800x600)" is selected for "Aspect ratio"

SW395 **SC385**

QVGA/ 800x600/ 1280x960

When "16:9" is selected for "Aspect ratio"

320x180/ 640x360 **SC384**

320x180/ 640x360/ 1280x720 **SW395** **SC385**

Default: VGA

[Recording priority]

Select "Constant bit rate" or "Frame rate" for the H.264 recording mode.

Constant bit rate: H.264 images will be recorded with the bit rate selected for "Max. bit rate".

Frame rate: H.264 images will be recorded with the frame rate selected for "Frame rate*".

Default: Frame rate

[Frame rate*]

Select the frame rate for images to be recorded from the following.

1fps/ 3fps/ 5fps*/ 7.5fps*/ 10fps*/ 12 fps*(PAL model)/ 15fps*/ 20fps*/ 30fps*

Default: 30fps*

Note:

- When "Frame rate" is selected for "Recording priority", this setting is available.
- "Frame rate*" is limited by "Max bit rate". For this reason, the frame rate may be lower than the specified value when any value marked with an asterisk (*) is selected.

[Max bit rate]

Select the bit rate for images to be recorded from the following.

64kbps/ 128kbps/ 256kbps/ 384kbps/ 512kbps/ 768kbps/ 1024kbps/ 1536kbps/ 2048kbps/ 3072kbps/ 4096kbps

Default: 1536kbps

[Image quality]

Select the quality for H.264 images to be recorded from the following.

Low(Motion priority)/ Normal/ Fine(Image quality priority)

Default: Normal

Note:

- When "Constant bit rate" is selected for "Recording priority", this setting is available.

[Refresh interval]

Select an interval (I-frame interval; 0.2 - 1 second) to refresh the H.264 images to be recorded from the following.

0.2s/ 0.25s/ 0.33s/ 0.5s/ 1s

Default: 1s

■ SD memory card information

[Remaining capacity]

Total capacity and remaining capacity of the SD memory card will be displayed.

Depending on the status of the SD memory card, the size indications will differ as follows.

Indication	Description
-----KB/-----KB	No SD memory card is inserted. Failed to obtain available capacity due to error, etc.
*****KB/*****KB	The SD card memory is unformatted, or locked, etc.

Note:

- When "Off" is selected for "Overwrite" and the available size of the SD memory card has reached "0 KB", images will not be saved on the SD memory card. When the notification function is on, a notification mail will be sent to the registered addresses when the SD memory card becomes full. (☞ Pages 83 and 84)

[Format]

To format the SD memory card, click the [Execute] button.

Important:

- Before formatting the SD memory card, it is necessary to select "Use" for "SD memory card" on the [SD memory card] tab of the "Basic" page (☞ page 33) and "Off" for "FTP periodic image transmission" on the [FTP img. trans.] tab of the "Network" page (☞ page 117).
- Use the SD memory card after formatting it using the [SD memory card] tab. If using the SD memory card that has not been formatted on the [SD memory card] tab, the following functions may not work correctly.
 - Save/obtain images that failed to transmit to the FTP server using the FTP periodic image transmission function
 - Save/obtain alarm images
 - Save/obtain images saved manually
 - Save/obtain images in accordance with the schedule settings
 - Save/obtain the alarm logs, the manual/schedule logs, the FTP error logs and the system logs

-
- Save/obtain images recorded using the SD memory recording function of Panasonic's network disk recorder.
 - Play/download images on the SD memory card
 - When an SD memory card is formatted while another user is in operation, the operation will be canceled.
 - It is impossible to access the SD memory card during the process of formatting.
 - All data saved on the SD memory card will be deleted when the SD memory card is formatted.
 - Do not turn off the power of the camera during the process of formatting.
 - When the setting of "Recording format" has been changed, it is recommended to format the SD memory card.
 - After formatting the SD memory card, available size may be smaller than the total size since the default directory is automatically created in the SD memory card.
 - Recommended SD memory card
Manufactured by Panasonic (option)
SDHC memory card: 4 GB, 8 GB, 16 GB, 32 GB
SD memory card: 256 MB, 512 MB, 1 GB, 2 GB
(except miniSD card and microSD card)
 - Use a SD memory card formatted compliant with the SD memory card standard at the default.
-

■ SD memory card images

[Access img.]

Images on the SD memory card can be obtained. Click the [Execute] button. Refer to page 38 for how to access images.

Access copy images saved on the SD memory card onto the PC [SD memory card images]

Click the [SD memory card] tab on the "Basic" page. (☞ Pages 26 and 27: How to display/operate the setup menu)
The following are descriptions of how to copy images saved on the SD memory card onto the PC. It is necessary in advance to select "Allow" for "FTP access to camera" on the [Network] tab of the "Network" page. (☞ Page 97)

Important:

- It may sometimes be impossible to operate when another user is accessing images on the SD memory card. In this case, retry later.
 - Depending on the settings of a proxy server or a firewall, images may not be obtained via a network. In this case, refer to the network administrator.
-

Step 1

Click the [Execute] button of "Access img."
→ The user authentication window will be displayed.

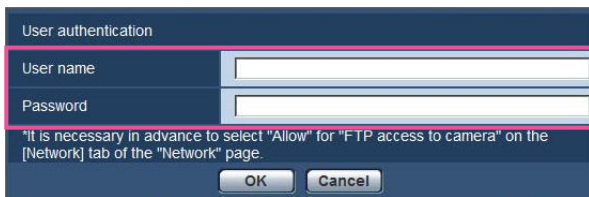

Step 2

Click the [OK] button after entering the user name and the password of the camera administrator.
→ The folder in which images are to be saved will be displayed.

Note:

- When logging in the FTP server of the camera to access images, the SD memory card will be allocated to the drive B.
Images are saved in different directories according to "Save trigger".
Move to the directory corresponding to the desired images and copy them.
Refer to page 141 for further information about the directory structure.
-

Possible number of images that can be saved on the SD memory card (as indications)

For JPEG images

Important:

- The numbers on the following table are just indications. They are not actual numbers of images that can be saved on the SD memory card. Numbers will differ according to photographic subject to the SD memory card.

Image capture size: 1 280 x 960

Capacity of SD/ SDHC memory card	Image quality				
	0(Super fine)	1(Fine)	2	3	4
32 GB	Approx. 64 000 pics	Approx. 80 000 pics	Approx. 96 000 pics	Approx. 112 000 pics	Approx. 128 000 pics
16 GB	Approx. 32 000 pics	Approx. 40 000 pics	Approx. 48 000 pics	Approx. 56 000 pics	Approx. 64 000 pics
8 GB	Approx. 16 000 pics	Approx. 20 000 pics	Approx. 24 000 pics	Approx. 28 000 pics	Approx. 32 000 pics
4 GB	Approx. 8 000 pics	Approx. 10 000 pics	Approx. 12 000 pics	Approx. 14 000 pics	Approx. 16 000 pics
2 GB	Approx. 4 000 pics	Approx. 5 000 pics	Approx. 6 000 pics	Approx. 7 000 pics	Approx. 8 000 pics
1 GB	Approx. 2 000 pics	Approx. 2 500 pics	Approx. 3 000 pics	Approx. 3 500 pics	Approx. 4 000 pics
512 MB	Approx. 1 000 pics	Approx. 1 250 pics	Approx. 1 500 pics	Approx. 1 750 pics	Approx. 2 000 pics
256 MB	Approx. 500 pics	Approx. 625 pics	Approx. 750 pics	Approx. 875 pics	Approx. 1 000 pics
Capacity of SD/ SDHC memory card	Image quality				
	5(Normal)	6	7	8	9(Low)
32 GB	Approx. 160 000 pics	Approx. 224 000 pics	Approx. 256 000 pics	Approx. 288 000 pics	Approx. 320 000 pics
16 GB	Approx. 80 000 pics	Approx. 112 000 pics	Approx. 128 000 pics	Approx. 144 000 pics	Approx. 160 000 pics
8 GB	Approx. 40 000 pics	Approx. 56 000 pics	Approx. 64 000 pics	Approx. 72 000 pics	Approx. 80 000 pics
4 GB	Approx. 20 000 pics	Approx. 28 000 pics	Approx. 32 000 pics	Approx. 36 000 pics	Approx. 40 000 pics
2 GB	Approx. 10 000 pics	Approx. 14 000 pics	Approx. 16 000 pics	Approx. 18 000 pics	Approx. 20 000 pics
1 GB	Approx. 5 000 pics	Approx. 7 000 pics	Approx. 8 000 pics	Approx. 9 000 pics	Approx. 10 000 pics
512 MB	Approx. 2 500 pics	Approx. 3 500 pics	Approx. 4 000 pics	Approx. 4 500 pics	Approx. 5 000 pics
256 MB	Approx. 1 250 pics	Approx. 1 750 pics	Approx. 2 000 pics	Approx. 2 250 pics	Approx. 2 500 pics

Image capture size: 1 280 x 720

Capacity of SD/ SDHC memory card	Image quality				
	0(Super fine)	1(Fine)	2	3	4
32 GB	Approx. 76 800 pics	Approx. 102 400 pics	Approx. 128 000 pics	Approx. 140 800 pics	Approx. 166 400 pics
16 GB	Approx. 38 400 pics	Approx. 51 200 pics	Approx. 64 000 pics	Approx. 70 400 pics	Approx. 83 200 pics
8 GB	Approx. 19 200 pics	Approx. 25 600 pics	Approx. 32 000 pics	Approx. 35 200 pics	Approx. 41 600 pics
4 GB	Approx. 9 600 pics	Approx. 12 800 pics	Approx. 16 000 pics	Approx. 17 600 pics	Approx. 20 800 pics
2 GB	Approx. 4 800 pics	Approx. 6 400 pics	Approx. 8 000 pics	Approx. 8 800 pics	Approx. 10 400 pics
1 GB	Approx. 2 400 pics	Approx. 3 200 pics	Approx. 4 000 pics	Approx. 4 400 pics	Approx. 5 200 pics
512 MB	Approx. 1 200 pics	Approx. 1 600 pics	Approx. 2 000 pics	Approx. 2 200 pics	Approx. 2 600 pics
256 MB	Approx. 600 pics	Approx. 800 pics	Approx. 1 000 pics	Approx. 1 100 pics	Approx. 1 300 pics
Capacity of SD/ SDHC memory card	Image quality				
	5(Normal)	6	7	8	9(Low)
32 GB	Approx. 230 400 pics	Approx. 294 400 pics	Approx. 358 400 pics	Approx. 384 000 pics	Approx. 409 600 pics
16 GB	Approx. 115 200 pics	Approx. 147 200 pics	Approx. 179 200 pics	Approx. 192 000 pics	Approx. 204 800 pics
8 GB	Approx. 57 600 pics	Approx. 73 600 pics	Approx. 89 600 pics	Approx. 96 000 pics	Approx. 102 400 pics
4 GB	Approx. 28 800 pics	Approx. 36 800 pics	Approx. 44 800 pics	Approx. 48 000 pics	Approx. 51 200 pics
2 GB	Approx. 14 400 pics	Approx. 18 400 pics	Approx. 22 400 pics	Approx. 24 000 pics	Approx. 25 600 pics
1 GB	Approx. 7 200 pics	Approx. 9 200 pics	Approx. 11 200 pics	Approx. 12 000 pics	Approx. 12 800 pics
512 MB	Approx. 3 600 pics	Approx. 4 600 pics	Approx. 5 600 pics	Approx. 6 000 pics	Approx. 6 400 pics
256 MB	Approx. 1 800 pics	Approx. 2 300 pics	Approx. 2 800 pics	Approx. 3 000 pics	Approx. 3 200 pics

Image capture size: 800 x 600 **SW395** **SC385**

Capacity of SD/SDHC memory card	Image quality				
	0(Super fine)	1(Fine)	2	3	4
32 GB	Approx. 102 400 pics	Approx. 160 000 pics	Approx. 192 000 pics	Approx. 243 200 pics	Approx. 281 600 pics
16 GB	Approx. 51 200 pics	Approx. 80 000 pics	Approx. 96 000 pics	Approx. 121 600 pics	Approx. 140 800 pics
8 GB	Approx. 25 600 pics	Approx. 40 000 pics	Approx. 48 000 pics	Approx. 60 800 pics	Approx. 70 400 pics
4 GB	Approx. 12 800 pics	Approx. 20 000 pics	Approx. 24 000 pics	Approx. 30 400 pics	Approx. 35 200 pics
2 GB	Approx. 6 400 pics	Approx. 10 000 pics	Approx. 12 000 pics	Approx. 15 200 pics	Approx. 17 600 pics
1 GB	Approx. 3 200 pics	Approx. 5 000 pics	Approx. 6 000 pics	Approx. 7 600 pics	Approx. 8 800 pics
512 MB	Approx. 1 600 pics	Approx. 2 500 pics	Approx. 3 000 pics	Approx. 3 800 pics	Approx. 4 400 pics
256 MB	Approx. 800 pics	Approx. 1 250 pics	Approx. 1 500 pics	Approx. 1 900 pics	Approx. 2 200 pics
Capacity of SD/SDHC memory card	Image quality				
	5(Normal)	6	7	8	9(Low)
32 GB	Approx. 320 000 pics	Approx. 384 000 pics	Approx. 422 400 pics	Approx. 460 800 pics	Approx. 480 000 pics
16 GB	Approx. 160 000 pics	Approx. 192 000 pics	Approx. 211 200 pics	Approx. 230 400 pics	Approx. 240 000 pics
8 GB	Approx. 80 000 pics	Approx. 96 000 pics	Approx. 105 600 pics	Approx. 115 200 pics	Approx. 120 000 pics
4 GB	Approx. 40 000 pics	Approx. 48 000 pics	Approx. 52 800 pics	Approx. 57 600 pics	Approx. 60 000 pics
2 GB	Approx. 20 000 pics	Approx. 24 000 pics	Approx. 26 400 pics	Approx. 28 800 pics	Approx. 30 000 pics
1 GB	Approx. 10 000 pics	Approx. 12 000 pics	Approx. 13 200 pics	Approx. 14 400 pics	Approx. 15 000 pics
512 MB	Approx. 5 000 pics	Approx. 6 000 pics	Approx. 6 600 pics	Approx. 7 200 pics	Approx. 7 500 pics
256 MB	Approx. 2 500 pics	Approx. 3 000 pics	Approx. 3 300 pics	Approx. 3 600 pics	Approx. 3 750 pics

Image capture size: VGA

Capacity of SD/SDHC memory card	Image quality				
	0(Super fine)	1(Fine)	2	3	4
32 GB	Approx. 160 000 pics	Approx. 224 000 pics	Approx. 256 000 pics	Approx. 288 000 pics	Approx. 320 000 pics
16 GB	Approx. 80 000 pics	Approx. 112 000 pics	Approx. 128 000 pics	Approx. 144 000 pics	Approx. 160 000 pics
8 GB	Approx. 40 000 pics	Approx. 56 000 pics	Approx. 64 000 pics	Approx. 72 000 pics	Approx. 80 000 pics
4 GB	Approx. 20 000 pics	Approx. 28 000 pics	Approx. 32 000 pics	Approx. 36 000 pics	Approx. 40 000 pics
2 GB	Approx. 10 000 pics	Approx. 14 000 pics	Approx. 16 000 pics	Approx. 18 000 pics	Approx. 20 000 pics
1 GB	Approx. 5 000 pics	Approx. 7 000 pics	Approx. 8 000 pics	Approx. 9 000 pics	Approx. 10 000 pics
512 MB	Approx. 2 500 pics	Approx. 3 500 pics	Approx. 4 000 pics	Approx. 4 500 pics	Approx. 5 000 pics
256 MB	Approx. 1 250 pics	Approx. 1 750 pics	Approx. 2 000 pics	Approx. 2 250 pics	Approx. 2 500 pics
Capacity of SD/SDHC memory card	Image quality				
	5(Normal)	6	7	8	9(Low)
32 GB	Approx. 352 000 pics	Approx. 416 000 pics	Approx. 448 000 pics	Approx. 480 000 pics	Approx. 512 000 pics
16 GB	Approx. 176 000 pics	Approx. 208 000 pics	Approx. 224 000 pics	Approx. 240 000 pics	Approx. 256 000 pics
8 GB	Approx. 88 000 pics	Approx. 104 000 pics	Approx. 112 000 pics	Approx. 120 000 pics	Approx. 128 000 pics
4 GB	Approx. 44 000 pics	Approx. 52 000 pics	Approx. 56 000 pics	Approx. 60 000 pics	Approx. 64 000 pics
2 GB	Approx. 22 000 pics	Approx. 26 000 pics	Approx. 28 000 pics	Approx. 30 000 pics	Approx. 32 000 pics
1 GB	Approx. 11 000 pics	Approx. 13 000 pics	Approx. 14 000 pics	Approx. 15 000 pics	Approx. 16 000 pics
512 MB	Approx. 5 500 pics	Approx. 6 500 pics	Approx. 7 000 pics	Approx. 7 500 pics	Approx. 8 000 pics
256 MB	Approx. 2 750 pics	Approx. 3 250 pics	Approx. 3 500 pics	Approx. 3 750 pics	Approx. 4 000 pics

Image capture size: 640 x 360

Capacity of SD/ SDHC memory card	Image quality				
	0(Super fine)	1(Fine)	2	3	4
32 GB	Approx. 192 000 pics	Approx. 281 600 pics	Approx. 332 800 pics	Approx. 358 400 pics	Approx. 409 600 pics
16 GB	Approx. 96 000 pics	Approx. 140 800 pics	Approx. 166 400 pics	Approx. 179 200 pics	Approx. 204 800 pics
8 GB	Approx. 48 000 pics	Approx. 70 400 pics	Approx. 83 200 pics	Approx. 89 600 pics	Approx. 102 400 pics
4 GB	Approx. 24 000 pics	Approx. 35 200 pics	Approx. 41 600 pics	Approx. 44 800 pics	Approx. 51 200 pics
2 GB	Approx. 12 000 pics	Approx. 17 600 pics	Approx. 20 800 pics	Approx. 22 400 pics	Approx. 25 600 pics
1 GB	Approx. 6 000 pics	Approx. 8 800 pics	Approx. 10 400 pics	Approx. 11 200 pics	Approx. 12 800 pics
512 MB	Approx. 3 000 pics	Approx. 4 400 pics	Approx. 5 200 pics	Approx. 5 600 pics	Approx. 6 400 pics
256 MB	Approx. 1 500 pics	Approx. 2 200 pics	Approx. 2 600 pics	Approx. 2 800 pics	Approx. 3 200 pics
Capacity of SD/ SDHC memory card	Image quality				
	5(Normal)	6	7	8	9(Low)
32 GB	Approx. 499 200 pics	Approx. 537 600 pics	Approx. 627 200 pics	Approx. 640 000 pics	Approx. 652 800 pics
16 GB	Approx. 249 600 pics	Approx. 268 800 pics	Approx. 313 600 pics	Approx. 320 000 pics	Approx. 326 400 pics
8 GB	Approx. 124 800 pics	Approx. 134 400 pics	Approx. 156 800 pics	Approx. 160 000 pics	Approx. 163 200 pics
4 GB	Approx. 62 400 pics	Approx. 67 200 pics	Approx. 78 400 pics	Approx. 80 000 pics	Approx. 81 600 pics
2 GB	Approx. 31 200 pics	Approx. 33 600 pics	Approx. 39 200 pics	Approx. 40 000 pics	Approx. 40 800 pics
1 GB	Approx. 15 600 pics	Approx. 16 800 pics	Approx. 19 600 pics	Approx. 20 000 pics	Approx. 20 400 pics
512 MB	Approx. 7 800 pics	Approx. 8 400 pics	Approx. 9 800 pics	Approx. 10 000 pics	Approx. 10 200 pics
256 MB	Approx. 3 900 pics	Approx. 4 200 pics	Approx. 4 900 pics	Approx. 5 000 pics	Approx. 5 100 pics

Image capture size: QVGA

Capacity of SD/ SDHC memory card	Image quality				
	0(Super fine)	1(Fine)	2	3	4
32 GB	Approx. 384 000 pics	Approx. 416 000 pics	Approx. 432 000 pics	Approx. 448 000 pics	Approx. 480 000 pics
16 GB	Approx. 192 000 pics	Approx. 208 000 pics	Approx. 216 000 pics	Approx. 224 000 pics	Approx. 240 000 pics
8 GB	Approx. 96 000 pics	Approx. 104 000 pics	Approx. 108 000 pics	Approx. 112 000 pics	Approx. 120 000 pics
4 GB	Approx. 48 000 pics	Approx. 52 000 pics	Approx. 54 000 pics	Approx. 56 000 pics	Approx. 60 000 pics
2 GB	Approx. 24 000 pics	Approx. 26 000 pics	Approx. 27 000 pics	Approx. 28 000 pics	Approx. 30 000 pics
1 GB	Approx. 12 000 pics	Approx. 13 000 pics	Approx. 13 500 pics	Approx. 14 000 pics	Approx. 15 000 pics
512 MB	Approx. 6 000 pics	Approx. 6 500 pics	Approx. 6 750 pics	Approx. 7 000 pics	Approx. 7 500 pics
256 MB	Approx. 3 000 pics	Approx. 3 250 pics	Approx. 3 375 pics	Approx. 3 500 pics	Approx. 3 750 pics
Capacity of SD/ SDHC memory card	Image quality				
	5(Normal)	6	7	8	9(Low)
32 GB	Approx. 512 000 pics	Approx. 576 000 pics	Approx. 608 000 pics	Approx. 640 000 pics	Approx. 672 000 pics
16 GB	Approx. 256 000 pics	Approx. 288 000 pics	Approx. 304 000 pics	Approx. 320 000 pics	Approx. 336 000 pics
8 GB	Approx. 128 000 pics	Approx. 144 000 pics	Approx. 152 000 pics	Approx. 160 000 pics	Approx. 168 000 pics
4 GB	Approx. 64 000 pics	Approx. 72 000 pics	Approx. 76 000 pics	Approx. 80 000 pics	Approx. 84 000 pics
2 GB	Approx. 32 000 pics	Approx. 36 000 pics	Approx. 38 000 pics	Approx. 40 000 pics	Approx. 42 000 pics
1 GB	Approx. 16 000 pics	Approx. 18 000 pics	Approx. 19 000 pics	Approx. 20 000 pics	Approx. 21 000 pics
512 MB	Approx. 8 000 pics	Approx. 9 000 pics	Approx. 9 500 pics	Approx. 10 000 pics	Approx. 10 500 pics
256 MB	Approx. 4 000 pics	Approx. 4 500 pics	Approx. 4 750 pics	Approx. 5 000 pics	Approx. 5 250 pics

Image capture size: 320 x 180

Capacity of SD/ SDHC memory card	Image quality				
	0(Super fine)	1(Fine)	2	3	4
32 GB	Approx. 460 800 pics	Approx. 524 800 pics	Approx. 563 200 pics	Approx. 576 000 pics	Approx. 614 400 pics
16 GB	Approx. 230 400 pics	Approx. 262 400 pics	Approx. 281 600 pics	Approx. 288 000 pics	Approx. 307 200 pics
8 GB	Approx. 115 200 pics	Approx. 131 200 pics	Approx. 140 800 pics	Approx. 144 000 pics	Approx. 153 600 pics
4 GB	Approx. 57 600 pics	Approx. 65 600 pics	Approx. 70 400 pics	Approx. 72 000 pics	Approx. 76 800 pics
2 GB	Approx. 28 800 pics	Approx. 32 800 pics	Approx. 35 200 pics	Approx. 36 000 pics	Approx. 38 400 pics
1 GB	Approx. 14 400 pics	Approx. 16 400 pics	Approx. 17 600 pics	Approx. 18 000 pics	Approx. 19 200 pics
512 MB	Approx. 7 200 pics	Approx. 8 200 pics	Approx. 8 800 pics	Approx. 9 000 pics	Approx. 9 600 pics
256 MB	Approx. 3 600 pics	Approx. 4 100 pics	Approx. 4 400 pics	Approx. 4 500 pics	Approx. 4 800 pics
Capacity of SD/ SDHC memory card	Image quality				
	5(Normal)	6	7	8	9(Low)
32 GB	Approx. 729 600 pics	Approx. 755 200 pics	Approx. 793 600 pics	Approx. 844 800 pics	Approx. 857 600 pics
16 GB	Approx. 364 800 pics	Approx. 377 600 pics	Approx. 396 800 pics	Approx. 422 400 pics	Approx. 428 800 pics
8 GB	Approx. 182 400 pics	Approx. 188 800 pics	Approx. 198 400 pics	Approx. 211 200 pics	Approx. 214 400 pics
4 GB	Approx. 91 200 pics	Approx. 94 400 pics	Approx. 99 200 pics	Approx. 105 600 pics	Approx. 107 200 pics
2 GB	Approx. 45 600 pics	Approx. 47 200 pics	Approx. 49 600 pics	Approx. 52 800 pics	Approx. 53 600 pics
1 GB	Approx. 22 800 pics	Approx. 23 600 pics	Approx. 24 800 pics	Approx. 26 400 pics	Approx. 26 800 pics
512 MB	Approx. 11 400 pics	Approx. 11 800 pics	Approx. 12 400 pics	Approx. 13 200 pics	Approx. 13 400 pics
256 MB	Approx. 5 700 pics	Approx. 5 900 pics	Approx. 6 200 pics	Approx. 6 600 pics	Approx. 6 700 pics

Configure the settings relating to the logs [Log]

Click the [Log] tab on the "Basic" page. (☞ Pages 26 and 27: How to display/operate the setup menu)
The settings relating to the log list can be configured in this section.

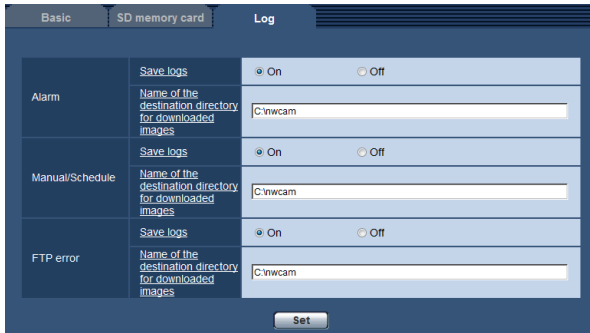

■ Alarm

Settings for the alarm log list can be performed.

[Save logs]

Select "On" or "Off" to determine whether to save the alarm logs.

On: Alarm logs will be saved.

Off: Alarm logs will not be saved.

Default: On

Note:

- When "H.264" is selected for "Recording format", "On" or "Off" will automatically be selected for "Save logs" according to the setting of "Save trigger".
- When "H.264" is selected for "Recording format" and when "Manual" or "Schedule" is selected for "Save trigger", alarm logs will not be saved.

[Name of the destination directory for downloaded images]

Enter the name of the destination directory to which images associated with the logs are to be downloaded. For example, enter "C:\alarm" to designate the folder "alarm" under drive C.

Available number of characters: 3 - 128 characters

Available characters: Alphanumeric characters, the slash (/), the backslash (\), the colon (:), and the underscore (_).

■ Manual/Schedule

Configure the settings relating to manual saving or schedule saving of the log list.

Select "On" or "Off" and designate the destination folder in the same manner as for "Alarm".

Note:

- When "H.264" is selected for "Recording format", "On" or "Off" will automatically be selected for "Save logs" according to the setting of "Save trigger".
- Schedule saving is available only when "H.264" is selected for "Recording format".

■ FTP error

Perform the settings for the FTP error log list. Select "On" or "Off" and designate the destination folder in the same manner as for "Alarm".

Important:

- When "Name w/o time&date" is selected for "File name" on the [FTP img. trans.] tab on the "Network" page, FTP error log and associated images will not be saved. To save them, select "Name w/ time&date". (☞ Page 117)

Note:

- When "H.264" is selected for "Recording format", "FTP error" is unavailable.

How the logs and images are saved depending on the settings for "Alarm"

[Log] tab	[SD memory card] tab		Logs and associated images
Alarm: Save logs	SD memory card	Save trigger	
On	Use	Alarm input	<p>Logs: Up to 5 000 logs will be kept. When more than 5 000 event logs are filed, the older event logs will be overwritten by the newer event logs.</p> <p>Images: Will be saved. When the remaining capacity of the SD memory card becomes insufficient, the older images will be overwritten by the newer images.</p>
		Other than "Alarm input"	<p>Logs: Up to 5 000 logs will be kept. When more than 5 000 logs are filed, the older logs will be overwritten by the newer logs. In this case, the oldest log is the first to be overwritten.</p> <p>Images: Will not be saved.</p>
	Not use	–	<p>Logs: Up to 1 000 logs will be kept. When more than 1 000 logs are filed, the older logs will be overwritten by the newer logs. In this case, the oldest log is the first to be overwritten. When the power of the camera is turned off, logs will be deleted.</p> <p>Images: Will not be saved.</p>
Off	Use	Alarm input	<p>Logs: Will not be saved.</p> <p>Images: Will be saved. When the remaining capacity of the SD memory card becomes insufficient, the older images will be overwritten by the newer images. * To display images on the SD memory card, it is necessary to copy them onto the PC first. (☞ Page 38)</p>
		Other than "Alarm input"	<p>Logs: Will not be saved.</p> <p>Images: Will not be saved.</p>
	Not use	–	<p>Logs: Will not be saved.</p> <p>Images: Will not be saved.</p>

How the logs and images are saved depending on the settings for "Manual/Schedule"

[Log] tab	[SD memory card] tab			Logs and associated images
Manual/ Schedule: Save logs	SD memory card	Save trigger	Overwrite	
On	Use	Manual/ Schedule	On	<p>Logs: Up to 5 000 logs will be kept. When more than 5 000 logs are filed, the older logs will be overwritten by the newer logs. In this case, the oldest log is the first to be overwritten.</p> <p>Images: Will be saved. When the remaining capacity of the SD memory card becomes insufficient, the older images will be overwritten by the newer images.</p>
			Off	<p>Logs: Up to 5 000 logs will be kept. When more than 5 000 logs are filed, no log will be filed newly anymore. Even when available capacity of the SD memory card ran out and it is not enough to save images, logs will be kept on being filed until it reaches 5 000 logs.</p> <p>Images: Will be saved. When available capacity of the SD memory card ran out, saving of images will become impossible. Even when available capacity of the SD memory card is enough, images associated with logs will be kept on being saved until number of filed logs reaches 5 000.</p>
		Other than "Manual/Schedule"	–	<p>Logs: Will not be saved.</p> <p>Images: Will not be saved.</p>
	Not use	–	–	<p>Logs: Will not be saved.</p> <p>Images: Will not be saved.</p>
Off	Use	Manual/ Schedule	On	<p>Logs: Will not be saved.</p> <p>Images: Will be saved. When the remaining capacity of the SD memory card becomes insufficient, the older images will be overwritten by the newer images. * To display images on the SD memory card, it is necessary to copy them onto the PC first. (Page 38)</p>
			Off	<p>Logs: Will not be saved.</p> <p>Images: Will be saved. When available capacity of the SD memory card ran out, saving of images will become impossible. * To display images on the SD memory card, it is necessary to copy them onto the PC first. (Page 38)</p>
		Other than "Manual/Schedule"	–	<p>Logs: Will not be saved.</p> <p>Images: Will not be saved.</p>
	Not use	–	–	<p>Logs: Will not be saved.</p> <p>Images: Will not be saved.</p>

How the logs and images are saved depending on the settings for "FTP error"

[Log] tab	[SD memory card] tab		Logs and associated images
FTP error: Save logs	SD memory card	Save trigger	
On	Use	FTP error	<p>Logs: Up to 5 000 logs will be kept. When more than 5 000 logs are filed, no log will be filed newly anymore. Even when available capacity of the SD memory card ran out and it is not enough to save images, logs will be kept on being filed until it reaches 5 000 logs.</p> <p>Images: Will be saved. When available capacity of the SD memory card ran out, saving of images will become impossible.</p>
		Other than "FTP error"	<p>Logs: Will not be saved.</p> <p>Images: Will not be saved.</p>
	Not use	–	<p>Logs: Will not be saved.</p> <p>Images: Will not be saved.</p>
Off	Use	FTP error	<p>Logs: Will not be saved.</p> <p>Images: Will be saved. When available capacity of the SD memory card ran out, saving of images will become impossible. * To display images on the SD memory card, it is necessary to copy them onto the PC first. (Page 38)</p>
		Other than "FTP error"	<p>Logs: Will not be saved.</p> <p>Images: Will not be saved.</p>
	Not use	–	<p>Logs: Will not be saved.</p> <p>Images: Will not be saved.</p>

Configure the settings relating to images and audio [Image/Audio]

The settings relating to JPEG, H.264 and MPEG-4 images such as the settings of image quality, audio, etc. can be configured on this page.

The "Image/Audio" page has 4 tabs; the [JPEG/H.264] tab (or [JPEG/MPEG-4] tab), the [Cam. Function] tab, the [Image/Position] tab and the [Audio] tab.

Configure the settings relating to the aspect ratio [JPEG/H.264]

Click the [JPEG/H.264] tab on the "Image/Audio" page. (☞ Pages 26 and 27: How to display/operate the setup menu)



[Aspect ratio]

Select the aspect ratio. It is impossible to activate "VGA" and "800x600" simultaneously. Select "VGA" or "800x600" when the aspect ratio is 4:3.

- 4:3 (VGA)
- 4:3 (800 x 600) **SW395** **SC385**
- 16:9

Default: 4:3 (VGA)

Note:

- When "4:3 (800x600)"* or "16:9" is selected, MPEG-4 transmission is unavailable.
* **SW395** **SC385**
- i-PRO Series does not support aspect ratio of "16:9". (As of October, 2010)
- When selecting "4:3 (800x600)"* or "16:9" for "Aspect ratio", "H.264" is automatically set for "Video encoding format".
* **SW395** **SC385**
- Image adjustment functions are activated for the angle of view in the aspect ratio of 4:3 even while "16:9" is being selected for "Aspect ratio". When setting the mask area for the back light compensation (BLC) function, it is recommended to configure the setting after selecting "4:3" for "Aspect ratio".

Configure the settings relating to JPEG images [JPEG/H.264] (or [JPEG/MPEG-4])

Click the [JPEG/H.264] tab (or [JPEG/MPEG-4] tab) on the "Image/Audio" page. (☞ Pages 26 and 27: How to display/operate the setup menu)



■ JPEG

Configure the settings such as "Refresh interval (JPEG)*", "Image capture size" and "Image quality" on this section. Refer to page 49 and 53 for further information about the settings relating to H.264 (or MPEG-4) images.

"Live" page (Initial display)

Configure the settings relating to the JPEG images displayed on the "Live" page.

[Refresh interval (JPEG)*]

Select an interval to refresh the displayed JPEG image from the following.

SW395

SC385

0.1 fps / 0.2 fps / 0.33 fps / 0.5 fps / 1 fps / 2 fps /
3 fps / 5 fps / 6 fps / 10 fps / 12 fps *(PAL only) /
15 fps * / 30 fps *

Default: 10 fps

SC384

0.1 fps / 0.2 fps / 0.33 fps / 0.5 fps / 1 fps / 2 fps /
3 fps / 5 fps / 6 fps * / 10 fps * / 12 fps *(PAL only) /
15 fps * / 30 fps *

Default: 5 fps

Note:

- When "On" is selected for "H.264 transmission" (or "MPEG-4 transmission"), the refresh interval may be longer than the set value when any value with an asterisk (*) on the right is selected.
-

[Image capture size]

Select the image capture size to display the JPEG image on the "Live" page for the first time.

When "4:3(VGA)" is selected for "Aspect ratio"

QVGA / VGA / 1280x960

When "4:3(800x600)" is selected for "Aspect ratio"

SW395

SC385

QVGA / 800x600 / 1280x960

When "16:9" is selected for "Aspect ratio"

320x180 / 640x360 / 1280x720

Default: 1280x960

[Image quality]

Select the capture size of the JPEG image displayed initially on the "Live" page.

Default: Quality1

[Image quality setting]

Select two types of image quality of JPEG images for each image capture size.

0 Super fine / 1 Fine / 2 / 3 / 4 / 5 Normal / 6 / 7 / 8 / 9 Low

Default: Quality1: 5 Normal

Quality2: 8

The setting for "Quality1" is activated for FTP periodic image transmission, files attached to alarm mails and SD memory recording.

Configure the settings relating to H.264 images [JPEG/H.264]

Click the [JPEG/H.24] tab on the "Image/Audio" page. (☞ Pages 26 and 27: How to display/operate the setup menu)

[JPEG/H.264] tab will be displayed when "H.264" is selected for "Video encoding format".

Configure the settings relating to H.264 image such as "Max bit rate (per client)", "Image capture size", "Image quality", etc. in this section. Refer to page 53 and 47 for the settings relating to MPEG-4 images and JPEG images respectively.

The screenshot shows a web interface for configuring video encoding settings. At the top, there are two tabs: "H.264" (selected) and "MPEG-4". Below the tabs, there are two sections: "H.264(1)" and "H.264(2)". Each section contains a list of settings with radio buttons for "On" and "Off", and various input fields for numerical values and text.

Setting	H.264(1) Value	H.264(2) Value
H.264 transmission	On	On
Internet mode (over HTTP)	On	On
Image capture size	1280x960	VGA
Transmission priority	Frame rate	Frame rate
Frame rate	30fps	30fps
Max bit rate (per client)	Max: 4096kbps, Min: 4096kbps	Max: 1536kbps, Min: 1536kbps
Image quality	Normal	Normal
Refresh interval	1s	1s
Transmission type	Unicast port (AUTO)	Unicast port (AUTO)
Unicast port1 (image)	33004 (1024-50000)	33014 (1024-50000)
Unicast port2 (Audio)	33004 (1024-50000)	33014 (1024-50000)
Multicast address	239.182.0.20	239.182.0.21
Multicast port	37004 (1024-50000)	37004 (1024-50000)
Multicast TTL/NOPLimit	16 (1-254)	16 (1-254)

[Video encoding format]

Select "H.264" for the video encoding format.

H.264: H.264 will be set for the video encoding format.

The subsequent setting items will be for H.264. The tab name will be changed to [JPEG/H.264].

MPEG-4: MPEG-4 will be set for the video encoding format. The subsequent setting items will be for MPEG-4. (☞ Page 53)

The tab name will be changed to [JPEG/MPEG-4].

Default: H.264

■H.264 (1) · H.264 (2)

[H.264 transmission]

Select "On" or "Off" to determine whether or not to transmit H.264 images.

On: Transmits H.264 images.

Off: Does not transmit H.264 images.

Default: On

Note:

- When "On" is selected for "H.264 transmission" in "H.264(1)" or "H.264(2)", displaying of H.264 images or JPEG images on the "Live" page will become available.
- When "On" is selected for "H.264 transmission" in "H.264(1)" and "H.264(2)", H.264 images are viewable using other devices with each setting.
- When "On" is selected for "H.264 transmission" in "H.264(1)" or "H.264(2)", the transmission interval of JPEG images may sometimes become longer.
- When "H.264" is selected for "Recording format", it is impossible to transmit H.264 images with the settings for "H.264(2)". In this case, the settings for "H.264(2)" are invalidated.

[Internet mode (over HTTP)]

Select "On" when transmitting H.264 images via the Internet. It is possible to transmit H.264 images without changing the broadband router settings configured for JPEG image transmission.

On: H.264 images and audio will be transmitted using the HTTP port. Refer to page 94 for further information about the HTTP port number settings.

Off: H.264 images and audio will be transmitted using the UDP port.

Default: Off

Note:

- When "On" is selected, only "Unicast port (AUTO)" will be available for "Transmission type".
- When "On" is selected, it may take time to start displaying H.264 images.

- When "On" is selected, H.264 images may not be displayed depending on the number of the concurrent access user and audio data availability, etc.
- When "On" is selected, only IPv4 access is available.

[Image capture size]

Select the image capture size from the following.

When "4:3(VGA)" is selected for "Aspect ratio"

H.264(1): QVGA/ VGA/ 1280x960

H.264(2): QVGA/ VGA

When "4:3(800x600)" is selected for "Aspect ratio"

SW395 **SC385**

H.264(1): QVGA/ 800x600/ 1280x960

H.264(2): QVGA/ 800x600

When "16:9" is selected for "Aspect ratio"

H.264(1): 320x180/ 640x360/ 1280x720

H.264(2): 320x180/ 640x360

Default: H.264(1): 1280x960

H.264(2): VGA

[Transmission priority]

Select a transmission priority for H.264 images from the following.

Constant bit rate: H.264 images will be transmitted with the bit rate selected for "Max bit rate (per client)".

Frame rate: H.264 images will be transmitted with the frame rate selected for "Frame rate".

Best effort: In accordance with the network bandwidth, H.264 images will be transmitted with the bit rate varying between the maximum and minimum bit rates that are set for "Max bit rate (per client)".

Default: Frame rate

Note:

- When "Frame rate" is selected for "Transmission priority", number of users who can access the camera may be limited more (may become less than 10).

[Frame rate*]

Select a frame rate for H.264 images from the following.

1fps/ 3fps/ 5fps*/ 7.5fps*/ 10fps*/ 12 fps* (PAL model)/ 15fps*/ 20fps*/ 30fps*

Default: 30fps*

Note:

- When "Frame rate" is selected for "Transmission priority", this setting is available.
- "Frame rate*" is limited by "Max bit rate". For this reason, the frame rate may be lower than the specified value when any value marked with an asterisk (*) is selected.

[Max bit rate (per client)*]

Select a H.264 bit rate per a client from the following. When "Best effort" is selected for "Transmission priority", set the maximum and minimum bit rates.

64kbps/ 128 kbps*/ 256kbps*/ 384kbps*/ 512kbps*/ 768kbps*/ 1024kbps*/ 1536kbps*/ 2048kbps*/ 3072kbps*/ 4096kbps*/ 8192kbps*/ Unlimited*

Default: H.264(1): 4096kbps*

H.264(2): 1536kbps*

* "8192kbps*" is available only when the image capture size is "1280x960" or "1280x720".

* "128 kbps*" is available only when the image capture size is "QVGA", "VGA", "800x600"*1 or "320x180", "640x360".

*1 **SW395** **SC385**

* "64kbps" is available only when the image capture size is "QVGA", "VGA" or "320x180", "640x360".

* "Unlimited*" is available only when "Frame rate" is selected for "Transmission priority".

Note:

- The H.264 bit rate is limited by "Bandwidth control(bit rate)" on the [Network] tab of "Network" page (page 97). For this reason, the bit rate may be lower than the value when any value with an asterisk (*) on the right is selected.
- When "8192 kbps*" or "Unlimited*" is selected, the number of users who can access H.264 images will be limited to "1". (Only a single user can access H.264 images.)
- It is impossible to select "Unlimited*" for both "H.264(1)" and "H.264(2)".

[Image quality]

Select the image quality of H.264 images from the following.

Low(Motion priority)/ Normal/ Fine(Image quality priority)

Default: Normal

Note:

- When "Constant bit rate" or "Best effort" is selected for "Transmission priority", this setting is available.
-

[Refresh interval]

Select an interval (I-frame interval; 0.2 - 5 seconds) to refresh the displayed H.264 images.

If using under a network environment with frequent error occurrences, shorten the refresh interval for H.264 to diminish image distortions. However, the refresh interval may be longer than the set value.

0.2s/ 0.25s/ 0.33s/ 0.5s/ 1s/ 2s/ 3s/ 4s/ 5s

Default: 1s

[Transmission type]

Select the transmission type of H.264 images from the following.

Unicast port (AUTO): Up to 14 users can access a single camera concurrently. "Unicast port1(Image)" and "Unicast port2(Audio)" will automatically be selected when transmitting images and audio from the camera. When it is unnecessary to fix the port number for H.264 image transmission such as when using in a particular LAN environment, it is recommended to select "Unicast port (AUTO)".

Unicast port (MANUAL): Up to 14 users can access a single camera concurrently. It is necessary to select "Unicast port1(Image)" and "Unicast port2(Audio)" manually to transmit images and audio from the camera.

It is possible to fix the port number of the router used for H.264 image transmission via the Internet by setting "Unicast port (MANUAL)" (☞ page 98). Refer to the operating instructions of the router in use.

Multicast: Unlimited number of users can access a single camera concurrently. Complete the entry field of "Multicast address", "Multicast port" and "Multicast TTL/HOPLimit" when transmitting H.264 images with multicast.

Refer to page 7 for further information about the maximum concurrent access number.

Default: Unicast port (AUTO)

[Unicast port1(Image)]*1

Enter the unicast port number (used to transmit images from the camera).

Available port number: 1024 - 50000 (Only even numbers are available.)

Default: H.264(1): 32004
H.264(2): 32014

[Unicast port2(Audio)]*1

Enter the unicast port number (used to transmit audio from the camera).

Available port number: 1024 - 50000 (Only even numbers are available.)

Default: H.264(1): 33004
H.264(2): 33014

[Multicast address]*2

Enter the multicast IP address.

Images and audio will be transmitted to the designated IP address.

Available IPv4 address: 224.0.0.0 - 239.255.255.255

Available IPv6 address: Multicast address starting with "FF"

Default: H.264(1): 239.192.0.20
H.264(2): 239.192.0.21

Note:

- Enter a multicast IP address after checking available multicast address.
-

[Multicast port]*2

Enter the multicast port number (used to transmit images from the camera).

Available port number: 1024 - 50000 (Only even numbers are available.)

Default: 37004

Note:

- When audio is transmitted from the unit, the port number to be used will be the multicast port number plus "1000".
-

[Multicast TTL/HOPLimit]*2

Enter a value for "Multicast TTL/HOPLimit".

Available value: 1-254

Default: 16

Important:

- When transmitting an H.264 image via a network, the transmitted image sometimes may not be displayed depending on the settings of a proxy server or a firewall. In this case, refer to the network administrator.
 - When two or more network interface cards are installed on the PC in use, the network interface card(s) not used for receiving images should be invalidated when displaying images using the multicast port.
-

*1 It is necessary to designate the unicast port number when "Unicast port (MANUAL)" is selected for "Transmission type".

*2 It is necessary to designate the multicast IP address when "Multicast" is selected for "Transmission type".

Configure the settings relating to MPEG-4 images [JPEG/MPEG-4]

Click the [JPEG/MPEG-4] tab on the "Image/Audio" page. (☞ Pages 26 and 27: How to display/operate the setup menu)

The [JPEG/MPEG-4] tab will be displayed when "MPEG-4" is selected for "Video encoding format". (☞ Page 49) Configure the settings relating to MPEG-4 image such as "Max bit rate (per client)*", "Image capture size", "Image quality", etc. in this section. Refer to page 47 and 49 for the settings relating to JPEG images and H.264 images respectively.

The screenshot shows a configuration page for video encoding. At the top, 'Video encoding format' is set to 'MPEG-4'. Below this are two sections, 'MPEG-4(1)' and 'MPEG-4(2)', each with a 'Set' button. Each section contains the following settings:

- MPEG-4 transmission: On Off
- Internet mode (over HTTP): On Off
- Image capture size: VGA
- Transmission priority: Frame rate
- Frame rate*: 30fps
- Max bit rate (per client)*: Max 2048kbps, Min 2048kbps
- Image quality: Normal
- Refresh interval: 1s
- Transmission type: Unicast port (AUTO)
- Unicast port1 (image): 32004 (1024-50000)
- Unicast port2 (Audio): 33004 (1024-50000)
- Multicast address: 239.192.0.20
- Multicast port: 37004 (1024-50000)
- Multicast TTL (HOPLimit): 16 (1-254)

[Video encoding format]

Select "MPEG-4" for the video encoding format.

■ MPEG-4 (1) · MPEG-4 (2)

[MPEG-4 transmission]

Select "On" or "Off" to determine whether or not to transmit MPEG-4 images.

On: Transmits MPEG-4 images.

Off: Does not transmit MPEG-4 images.

Default: On

Important:

- When "4:3(800x600)** or "16:9" is selected for "Aspect ratio", MPEG-4 transmission is unavailable.
* **SW395** **SC385**
- When "H.264" is selected for "Recording format", MPEG-4 transmission is unavailable.

Note:

- When "On" is selected for "MPEG-4 transmission" in "MPEG-4(1)" or "MPEG-4(2)", displaying of MPEG-4 images or JPEG images on the "Live" page will be available.
- When "On" is selected for "MPEG-4 transmission" in "MPEG-4(1)" and "MPEG-4(2)", MPEG-4 images are viewable using other devices with each setting.
- When "On" is selected for "MPEG-4 transmission" in "MPEG-4(1)" or "MPEG-4(2)", the transmission interval of JPEG images may be longer.

[Internet mode (over HTTP)]

Select "On" when transmitting MPEG-4 images via the Internet. It is possible to transmit MPEG-4 images without changing the broadband router settings configured for JPEG image transmission.

On: MPEG-4 images and audio will be transmitted using the HTTP port. Refer to page 94 for further information about the HTTP port number settings.

Off: MPEG-4 images and audio will be transmitted using the UDP port.

Default: Off

Note:

- When "On" is selected, only "Unicast port (AUTO)" will be available for "Transmission type".
 - When "On" is selected, it may take seconds to start displaying MPEG-4 images.
 - When "On" is selected, MPEG-4 images may not be displayed depending on the number of the concurrent access users and audio data availability, etc.
 - When "On" is selected, only IPv4 access is available.
-

[Image capture size]

Select "QVGA" or "VGA" for the image capture size of MPEG-4 images.

Default: MPEG-4(1): VGA
MPEG-4(2): VGA

[Transmission priority]

Select a transmission priority for MPEG-4 images from the following.

Constant bit rate: MPEG-4 images will be transmitted with the bit rate selected for "Max bit rate (per client)*".

Frame rate: MPEG-4 images will be transmitted with the frame rate selected for "Frame rate*".

Best effort: In accordance with the network bandwidth, MPEG-4 images will be transmitted with the bit rate varying between the maximum and minimum bit rates that are set for "Max bit rate (per client)*".

Default: Frame rate

Note:

- When "Frame rate" is set for "Transmission priority", number of users who can access the camera may be limited more (may become less than 10).
-

[Frame rate*]

Select a frame rate for MPEG-4 images from the following.

1fps/ 3fps/ 5fps*/ 7.5fps*/ 10fps*/ 12 fps*(PAL model)/ 15fps*/ 20fps*/ 30fps*

Default: 30fps*

Note:

- When "Frame rate" is selected for "Transmission priority", this setting is available.
 - "Frame rate*" is limited by "Max bit rate (per client)*". For this reason, the frame rate may be lower than the specified value when any value marked with an asterisk (*) is selected.
-

[Max bit rate (per client)*]

Select a MPEG-4 bit rate per a client from the following. When "Best effort" is selected for "Transmission priority", set the maximum and minimum bit rates.

64kbps/ 128kbps*/ 256kbps*/ 384kbps*/ 512kbps*/ 768kbps*/ 1024kbps*/ 1536kbps*/ 2048kbps*/ 3072kbps*/ 4096kbps*/ Unlimited*

Default:

MPEG-4(1): 2048kbps*
MPEG-4(2): 2048kbps*

* "Unlimited*" is available only when "Frame rate" is selected for "Transmission priority".

Note:

- The MPEG-4 bit rate is limited by "Bandwidth control(bit rate)" on the [Network] tab of "Network" page (page 97). For this reason, the bit rate may be lower than the value when any value with an asterisk (*) on the right is selected.
 - When "Unlimited*" is selected, the number of users who can access MPEG-4 images will be limited to "1".
(Only a single user can access MPEG-4images.)
 - It is impossible to select "Unlimited*" for both "MPEG-4(1)" and "MPEG-4(2)".
-

[Image quality]

Select the image quality of MPEG-4 images from the following.

Low(Motion priority)/ Normal/ Fine(Image quality priority)

Default: Normal

Note:

- When "Constant bit rate" or "Best effort" is selected for "Transmission priority", this setting is available.
-

[Refresh interval]

Select an interval (I-frame interval; 0.2 - 5 seconds) to refresh the displayed MPEG-4 images.

If using under a network environment with frequent error occurrences, shorten the refresh interval for MPEG-4 to diminish image distortions. However, the refresh interval may be longer than the set value.
0.2s/ 0.25s/ 0.33s/ 0.5s/ 1s/ 2s/ 3s/ 4s/ 5s

Default: 1s

[Transmission type]

Select the transmission type of MPEG-4 images from the following.

Unicast port (AUTO): Up to 14 users can access a single camera concurrently. "Unicast port1 (Image)" and "Unicast port2 (Audio)" will automatically be selected when transmitting images and audio from the camera. When it is unnecessary to fix the port number for MPEG-4 image transmission such as when using in a particular LAN environment, it is recommended to select "Unicast port (AUTO)".

Unicast port (MANUAL): Up to 14 users can access a single camera concurrently. It is necessary to select "Unicast port1 (Image)" and "Unicast port2 (Audio)" manually to transmit images and audio from the camera.

It is possible to fix the port number of the router used for MPEG-4 image transmission via the Internet by setting "Unicast port (MANUAL)" (page 98). Refer to the operating instructions of the router in use.

Multicast: Unlimited number of users can access a single camera concurrently. Complete the entry field of "Multicast address", "Multicast port" and "Multicast TTL/HOPLimit" when transmitting MPEG-4 images with multicast.

* Refer to page 7 for further information about the maximum concurrent access number.

Default: Unicast port (AUTO)

[Unicast port1 (Image)]*¹

Enter the unicast port number (used to transmit images from the camera).

Available port number: 1024-50000 (Only even numbers are available.)

Default: MPEG-4(1): 32004
MPEG-4(2): 32014

[Unicast port2 (Audio)]*¹

Enter the unicast port number (used to transmit audio from the camera).

Available port number: 1024-50000 (Only even numbers are available.)

Default: MPEG-4(1): 33004
MPEG-4(2): 33014

[Multicast address]*²

Enter the multicast IP address.

Images and audio will be transmitted to the designated IP address.

Available IPv4 address: 224.0.0.0 - 239.255.255.255

Available IPv6 address: Multicast address starting with "FF"

Default: MPEG-4(1): 239.192.0.20
MPEG-4(2): 239.192.0.21

Note:

- Enter a multicast IP address after checking available multicast address.

[Multicast port]*²

Enter the multicast port number (used to transmit images from the camera).

Available port number: 1024 - 50000 (Only even numbers are available.)

Default: 37004

Note:

- When audio is transmitted from the camera, the port number to be used will be the multicast port number plus "1000".

[Multicast TTL/HOPLimit]*²

Enter the multicast TTL/HOPLimit value.

Available value: 1 - 254

Default: 16

Important:

- When transmitting an MPEG-4 image via a network, the transmitted image sometimes may not be displayed depending on the settings of a proxy server or a firewall. In this case, refer to the network administrator.
- When two or more network interface cards are installed on the PC in use, the network interface card(s) not used for receiving images should be invalidated when displaying images using the multicast port.

- *1 It is necessary to designate the unicast port number when "Unicast port (MANUAL)" is selected for "Transmission type".
- *2 It is necessary to designate the multicast IP address when "Multicast" is selected for "Transmission type".

Configure the settings relating to the camera operations [Cam. Function]

Click the [Cam. Function] tab on the "Image/Audio" page. (☞ Pages 26 and 27: How to display/operate the setup menu)

Configure the settings relating to camera operations.



[Home position]

A preset position (☞ page 67) can be set as the home position.

When a preset position is set as the home position, "H" will be displayed next to the preset position number.

Default: Off

Note:

- To move the camera to the home position when the power of the camera is turned on, select "Home position" for "Self return".

[Self return]

When the time set for "Self return time" has passed after manual operations of the camera, the camera will automatically be in the selected mode.

Off: Self return is not performed.

Home position: When the set time has passed, the camera will move to the home position automatically.

Auto track **SW395** **SC385**: When the set time has passed, the camera will move to the home position and will start the auto track function. The camera will repeat this action (moving to the home position and starting the auto track function) afterward.

Auto pan: When the set time has passed, the camera will start the auto pan function.

Preset sequence: When the set time has passed, the camera will start the sequence display.

Default: Off

Note:

- This function is also useful to automatically set the camera in a specific mode when the power of the camera is turned on.
- The self return function works even when the setup menu is displayed.

[Self return time]

Select a waiting time (amount of time until the camera starts the selected operation after the end of the manual operations) from the following.

10s/ 20s/ 30s/ 1min/ 2min/ 3min/ 5min/ 10min/ 20min/ 30min/ 60min

Default: 1min

[Image hold]

Select "On" or "Off" to determine whether or not to hold the still image on the screen (that is displayed at the last moment before the camera started to move to a preset position) until the camera has moved to the preset position.

On: A still image will be held on the screen until the camera has moved to the preset position.

Off: Images from the camera will be displayed even when the camera is moving to the preset position.

Default: Off

[Upside-down] **SW395** **SC385**

Select "On (desktop)" or "Off (ceiling)" to determine how the camera is to be installed.

On (desktop): Select this when the camera is to be installed with the dome side up.

Off (ceiling): Select this when the camera is to be installed with the dome side down.

Default: Off (ceiling)

[Extra optical zoom]

Select the extra optical zoom setting from the following.

On (Max X36): Images can be zoomed in on with the optical zoom (1x - 18x) and the extra optical zoom (higher zoom factors, up to 36x).

Off (Max X18): Does not use the extra optical zoom.

Default: On (Max X36)

About extra optical zoom

Among approx. 1.3 megapixel image capture area of the MOS image sensor, the central part of approx. 0.31 megapixels is extracted for shooting. That enables the shooting with a higher zooming effect. When the image capture size under "VGA" is applied, the zoom factor can be adjusted up to 36x.

[Digital zoom]

Select the digital zoom setting from the following.

On (Max X288) **SC384 :** Images can be zoomed in on with the optical zoom (1x - 18x), extra optical zoom (up to 36x) and the electronic zoom (higher zoom factors, up to 288x).

On (Max X432) **SW395 **SC385** :** Images can be zoomed in on with the optical zoom (1x - 18x), extra optical zoom (up to 36x) and the electronic zoom (higher zoom factors, up to 432x).

Off: Does not use the digital zoom.

Default: Off

Note:

- When "On (Max X288)" **SC384** or "On (Max X432)" **SW395** **SC385** is selected, digital zooming will stop when the zoom factor has reached 36x.
- When the zoom factor is 36x or more, the setting of the preset positions will become unavailable.

[Pan-Tilt degree/Zoom ratio display]

Select "On" or "Off" to determine whether or not to display the current panning/tilting degree and the zoom factor on images when the camera is being operated manually.

On: Displays the current panning/tilting degree and the zoom factor.

Off: Does not display the current panning/tilting degree and the zoom factor.

Default: On

Note:

- When "On" is selected, the panning/tilting degree and the zoom factor will be displayed at the position selected for "OSD Position" on the [Basic] tab of the "Basic setup" page. (Page 31)

[Tilt Angle]

Select the maximum degree for tilting from the following.

(Level = 0°)

10°/ 5°/ 3°/ 0°/ -3°/ -5°/ -10°/ -15°/ -20°/ -25°/ -30°

Default: 0°

Note:

- When using an inner cover (WV-Q157 or an accessory of optional mount bracket), upper side of images will be hidden (become black) when the tilt angle of the camera is almost level. (When "-5°" is selected for "Tilt Angle" on the setup menu, upper half of images will be hidden.) In this case, images will also be washed out depending on the object when "On" is selected for "AGC" on the setup menu (page 60). **SC384** **SC385**
- If "-20°", "-25°" or "-30°" is selected, the area hidden by the camera housing may increase when the tilt angle of the camera is almost level. **SW395**

[Pan/tilt-flip]

Select the pan/tilt-flip setting from the following.

On: When the camera reaches the panning or tilting end during manual operation, the camera pans or tilts at high speed to the reverse direction. In this way, it is possible to control the camera without having to stop panning/tilting and displaying images in proper orientation.

Off: Pan/tilt-flip does not work.

Default: On

Note:

- The pan/tilt-flip function cannot be activated by clicking live images.
 - When the zoom ratio is adjusted to the "TELE" side, images will be partially hidden even if the pan/tilt-flip function is activated.
-

Configure the settings relating to images and the preset positions [Image/Position]

Click the [Image/Position] tab on the "Image/Audio" page. (☞ Pages 26 and 27: How to display/operate the setup menu)

When the [Setup>>] button of each setting item is clicked, the detailed settings menu will be displayed in a newly opened window. The detailed settings can be configured while monitoring images displayed on the [Image/Position] tab.

The following are descriptions of how to configure the settings relating to image quality, preset positions, auto pan function, privacy zone, etc.

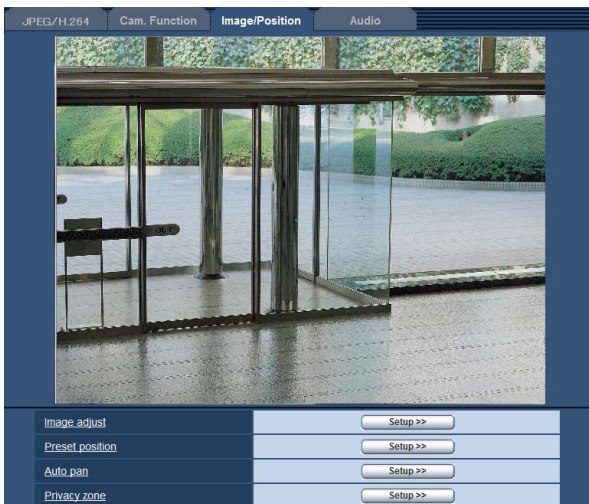

[Auto pan]

Click the [Setup>>] button to display the setup menu that can configure the settings relating to the auto pan function. The setup menu will be displayed in a newly opened window. (☞ Page 70)

[Privacy zone]

Click the [Setup>>] button to display the setup menu that can configure the settings relating to the privacy zone. The setup menu will be displayed in a newly opened window. (☞ Page 71)

[Image adjust]

Click the [Setup>>] button to display the setup menu that can configure the settings relating to image quality. The setup menu will be displayed in a newly opened window.

(☞ Page 59) **SW395** **SC385**

(☞ Page 63) **SC384**

[Preset position]

Click the [Setup>>] button to display the setup menu that can configure the settings relating to the preset positions. The setup menu will be displayed in a newly opened window. (☞ Page 67)

Configure the settings relating to image quality ("Image adjust" setup menu) SW395 SC385

Click the [Setup >>] button of "Image adjust" on the [Image/Position] tab of the "Image/Audio" page. (Page 58)
The settings relating to image quality can be configured with the setup menu displayed in a newly displayed window. When the values are changed, the changed values will be applied to the currently displayed image on the [Image/Position] tab.

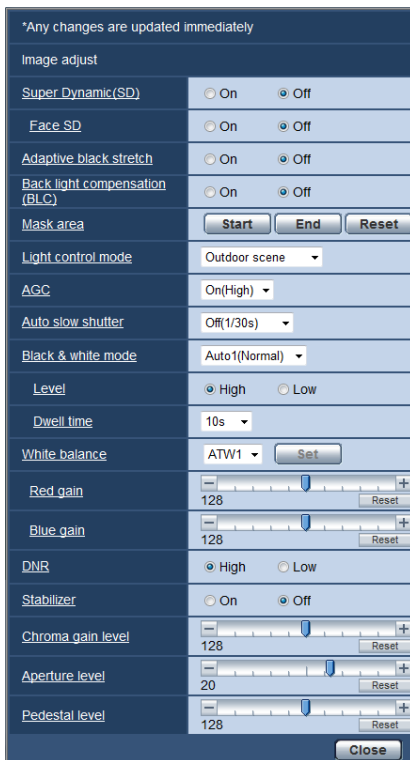

[Super Dynamic(SD)]

Select "On" or "Off" to determine whether or not to activate the super dynamic function.

Refer to the description "Super Dynamic function" about the super dynamic function.

On: The super dynamic function will work.

Off: The super dynamic function will not work.

Default: Off

Note:

- When the following are observed depending on the light condition, select "Off" for "Super Dynamic(SD)".
- When flickering appears or the color changes on the screen
- When noise appears in the brighter area on the screen
- When "Outdoor scene" or "Indoor scene" is selected for "Light control mode", this setting is available.

Super Dynamic function

When there is wide variation between the illumination of light and dark areas of the location being monitored, the camera adjusts the lens iris in accordance with the brighter areas. This causes loss of detail in darker areas. Conversely, adjusting the lens brightness for the darker areas causes the brighter areas to become washed out.

Super Dynamic digitally combines an image that is set up for a clear view of the brighter areas with an image that is set up for a clear view of the darker areas, creating a final image that preserves overall detail.

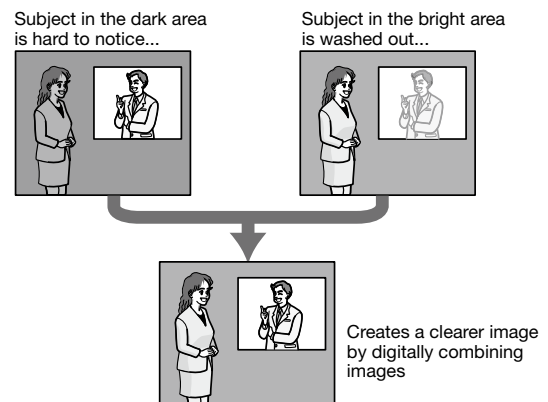

[Face SD]

Select "On" or "Off" to determine whether or not to interact with the Super Dynamic function.

On: The interactive control with face detection will work.

Off: The interactive control with face detection will not work.

Default: Off

Note:

- When "Off" is selected for "Super Dynamic(SD)", the interactive control with face detection is deactivated.

[Adaptive black stretch]

Select "On" or "Off" to determine whether or not to activate the darkness compensation function. The darkness compensation function can make darker parts of images brighter by digital image processing.

On: Activates the darkness compensation function.

Off: Deactivates the darkness compensation function.

Default: Off

Important:

- When "On" is selected for "Adaptive black stretch", noise in the darker parts may be increased, and parts around borders between the darker parts and the brighter parts may become darker/brighter than the other darker/brighter parts.

[Back light compensation (BLC)]

Select "On" or "Off" to determine whether or not to activate the back light compensation (BLC) function. When "On" is selected for "Super Dynamic(SD)", this setting is unavailable.

The back light compensation function can compensate back light by setting mask areas on brighter parts of images brighter.

On: Mask areas will be set automatically.

Off: Mask areas will not be set automatically. It is necessary to set them manually.

Default: Off

[Mask area]

When "Off" is selected for "Super Dynamic(SD)" and "Back light compensation(BLC)", it is possible to compensate for backlight by masking brighter areas.

Refer to page 66 for information on how to set the mask area.

[Light control mode]

Select the light control mode from the following.

Outdoor scene: Depending on the brightness level (illuminance), the iris will automatically be controlled together with the shutter speed adjustment to control light. When shooting a bright subject such as outdoor, etc., select this parameter. Be aware that flicker may occur when a subject is under fluorescent lighting.

Indoor scene (50 Hz)

Indoor scene (60 Hz): The shutter speed will automatically be adjusted to prevent flicker caused by fluorescent light.

Select 50 Hz or 60 Hz corresponding to the location where the camera is in use.

Fix shutter: The selected value will be set as the fixed shutter speed.

1/30 fix, 3/100 fix, 3/120 fix, 2/100 fix, 2/120 fix, 1/100 fix, 1/120 fix, 1/250 fix, 1/500 fix, 1/1000 fix, 1/2000 fix, 1/4000 fix, 1/10000 fix

Default: Outdoor scene

Note:

- When a faster shutter speed is selected (up to 1/10000), it is possible to capture a fast moving object with less blur.
- When a faster shutter speed is selected, the sensitivity will become lower. Smear also may appear under bright light condition.
- When "On" is selected for "Super Dynamic(SD)", only "Outdoor scene" and "Indoor scene" are available.

[AGC]

Select a method of gain adjustment from the following.

On(High)/ On(Mid)/ On(Low): When the luminance of the subject becomes darker, gain will be automatically incremented and screen will become brighter. "High", "Mid" and "Low" are indications of gain level.

Off: Images will be captured with the fixed gain level.

Default: On(High)

[Auto slow shutter]

The electronic sensitivity enhancement (sensitivity up) can be carried out by adjusting the storage time of the sensor.

The following are available for the recording duration.

Off(1/30s), Max.2/30s, Max.4/30s, Max.6/30s, Max.10/30s, Max.16/30s

Default: Off(1/30s)

Important:

- When "On" is selected for "Auto slow shutter", frame rate may become lower. Noise or white dots (blemishes) may sometimes appear.

Note:

- When "Max.16/30s" is selected, for example, sensitivity will automatically be increased up to x16. When "Off" is selected for "AGC", this setting is unavailable.
-

[Black & white mode]

Select switching between the color mode and the black & white mode from the following.

Off: The color mode is selected.

On: The black & white mode is selected.

Auto1(Normal): The camera automatically switches between the color mode and the black & white mode in accordance with picture brightness (luminance). The black & white mode will automatically be selected when the lighting condition becomes darker, while the color mode will automatically be selected when it becomes brighter.

Auto2(IR Light): Suitable when using near-infrared light source at night.

Auto3(Super Chrome Compensation(SCC)): Suitable to keep the color mode even under darker light condition.

The color mode will be carried on by the Super Chrome Compensation (SCC) function even under illumination that is lower than Auto 1.

Default: Auto1(Normal)

Super Chrome Compensation (SCC) function

This function achieves faithful color images using the proprietary color compensation technology that reproduce images even under low illumination where it is usually difficult to capture objects faithfully.

Note:

- The operating sound might be heard when changing to black-and-white mode, however it does not indicate any malfunction.
 - Since the color compensation technology is used for Auto 3, some colors may look different from the actual objects depending on the light condition.
-

[Level]

Select the threshold illuminance level (brightness) to switch between the color mode and the black & white mode.

The descriptions about the following threshold illuminance levels are given when "Off" is selected for "Super Dynamic(SD)".

- **When "Black & white mode" is set to "Auto1" or "Auto2"**

High: Switches from the color mode to the black & white mode when the ambient brightness (illuminance) of the camera is approx. 6 lx or less.

Low: Switches from the color mode to the black & white mode when the ambient brightness (illuminance) of the camera is approx. 2 lx or less.

- **When "Black & white mode" is set to "Auto3".**

High: Carries on the color mode by activating the super chroma compensation function when the ambient brightness (illuminance) of the camera is approx. 6 lx or less.

When the color temperature of the object becomes approx. 3 500 K or lower, the color mode will be switched to the black & white mode.

Low: Carries on the color mode by activating the super chroma compensation function when the ambient brightness (illuminance) of the camera is approx. 2 lx or less.

When the color temperature of the object becomes approx. 3 500 K or lower, the color mode will be switched to the black & white mode.

Default: High

[Dwell time]

Select a wait time for switching between the color mode and the black & white mode from the following.
2s/ 10s/ 30s/ 1min

Default: 10s

[White balance]

Select a method of white balance adjustment from the following.

White color can be adjusted by "Red gain" and "Blue gain".

ATW1: Selects the automatic tracing white balance mode. The camera will constantly check the color temperature of the light source and adjust the white balance automatically. Operating color temperature range is approx. 2 700 K to 6 000 K.

ATW2: Selects the automatic tracing white balance mode under a sodium lamp. The camera will adjust the white balance automatically under a sodium lamp. Operating color temperature range is approx. 2 000 K to 6 000 K.

AWC: Selects the automatic white balance control mode. This adjustment is suitable for a location where a light source is stable. Operating color temperature range is approx. 2 000 K to 10 000 K.

Default: ATW1

Note:

- Under the following conditions, color may not be faithfully processed. In these cases, select "AWC".
 - When shooting a subject whose major part is a thick color
 - When shooting blue sky or sun at sunset
 - When shooting a subject whose luminance is too low
 - When "AWC" is selected, click the [Set] button.
-

[Red gain]

Adjust the red color of images.

When the cursor is moved in the "+" direction, the red color will become thicker. When the cursor is moved in the "-" direction, the red color will be thinner. Click the [Reset] button to reset the color to the default.

Default: 128

[Blue gain]

Adjust the blue color of images.

When the cursor is moved in the "+" direction, the blue color will become thicker. When the cursor is moved in the "-" direction, the blue color will be thinner. Click the [Reset] button to reset the color to the default.

Default: 128

[DNR]

The digital noise reduction function reduces noise automatically under the condition of low illuminance. Select an effect level "High" or "Low" for the digital noise reduction.

High: High DNR, afterimage remains

Low: Low DNR, reduces afterimage

Default: High

[Stabilizer]

Select "On" or "Off" to determine whether or not to activate the image stabilizer.

Default: Off

Important:

- If "On" is selected for the image stabilizer, the view angle will become narrower and the resolution becomes lower. When "On" is selected, check the view angle and resolution at camera installation. The image stabilizer function may not work for the following photographic subjects:
 - Dark subject
 - Less contrast subject (e.g. white wall)

- Short cycled image shaking such as mechanical vibration
 - Large amplitude image shaking
 - Image stabilization may not be effective in the following case.
 - Image stabilization may not be effective in the following case.
 - When a parameter other than "Off(1/30s)" is selected for "Auto slow shutter"
-

[Chroma gain level]

Adjusts the chroma level (color density).

When the cursor is moved in the "+" direction, the colors will become thicker. When the cursor is moved in the "-" direction, the colors will be thinner. Click the [Reset] button to reset the color to the default.

Default: 128

[Aperture level]

Adjust the aperture level (outline compensation).

Images will be sharper when the cursor is moved in the "+" direction, and will be softer when the cursor is moved in the "-" direction. Click the [Reset] button to reset the color to the default.

Default: 20

[Pedestal level]

Adjust the black level of images by moving the cursor.

When the cursor is moved to the "+" direction, images will become brighter. When the cursor is moved to the "-" direction, images will be darker. Click the [Reset] button to reset the color to the default.

Default: 128

[Close] button

Click this button to quit the "Image adjust" setup menu.

Configure the settings relating to image quality ("Image adjust" setup menu) SC384

Click the [Setup >>] button of "Image adjust" on the [Image/Position] tab of the "Image/Audio" page. (☞ page 58)
 The settings relating to image quality can be configured with the setup menu displayed in a newly displayed window. When the values are changed, the changed values will be applied to the currently displayed image on the [Image/Position] tab.

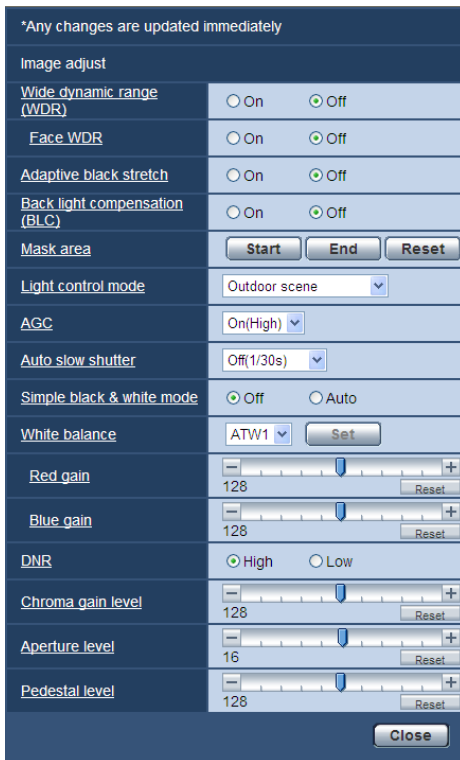

[Wide dynamic range(WDR)]

Select "On" or "Off" to determine whether or not to activate the wide dynamic range function. This function compensates brightness so that it produces clearer images even if objects have various illumination intensities.
On: The wide dynamic range function will work.
Off: The wide dynamic range function will not work.
Default: Off

Note:

- When the wide dynamic range function is activated, noise may be increased in the dark area of the object.
- When "Outdoor scene" or "Indoor scene" is selected for "Light control mode", this setting is available.

[Face WDR]

The "Face WDR" setting can calibrate the illuminance level of people's faces on images to improve the visibility by synchronizing the face detection function with the wide dynamic range function when their faces are too dark to recognize.

Select "On" or "Off" to determine whether or not to interact with the face detection function.

On: The interactive control with face detection will work. The wide dynamic range controls over around face.

Off: The interactive control with face detection will not work.

Default: Off

Note:

- When "Off" is selected for "Wide dynamic range", it is impossible to activate the "Face WDR" setting.
- There may be some cases that the effect is not distinct when the faces are too dark to recognize due to strong backlight.

[Adaptive black stretch]

Select "On" or "Off" to determine whether or not to activate the darkness compensation function. The darkness compensation function can make darker parts of images brighter by digital image processing.

On: Activates the darkness compensation function.

Off: Deactivates the darkness compensation function.

Default: Off

Important:

- When "On" is selected for "Adaptive black stretch", noise in the darker parts may be increased, and parts around borders between the darker parts and the brighter parts may become darker/brighter than the other darker/brighter parts.

Note:

- When "On" is selected for "Wide dynamic range", the "Adaptive black stretch" setting is unavailable.

[Back light compensation(BLC)]

Select "On" or "Off" to determine whether or not to activate the back light compensation (BLC) function. When "On" is selected for "Wide dynamic range", this setting is unavailable.

The back light compensation function can compensate back light by setting mask areas on brighter parts of images brighter.

On: Mask areas will be set automatically.

Off: Mask areas will not be set automatically. It is necessary to set them manually.

Default: Off

[Mask area]

When "Off" is selected for "Wide dynamic range" and "Back light compensation(BLC)", it is possible to compensate for backlight by masking brighter areas.

Refer to page 66 for information on how to set the mask area.

[Light control mode]

Select the light control mode from the following.

Outdoor scene: Depending on the brightness level (illuminance), the iris will automatically be controlled together with the shutter speed adjustment to control light. When shooting a bright subject such as outdoor, etc., select this parameter. Be aware that flicker may occur when a subject is under fluorescent lighting.

Indoor scene (60 Hz)

Indoor scene (50 Hz): The shutter speed will automatically be adjusted to prevent flicker caused by fluorescent light.

Select 50 Hz or 60 Hz corresponding to the location where the camera is in use.

Fix shutter: The selected value will be set as the fixed shutter speed.

1/30 fix, 3/100 fix, 3/120 fix, 2/100 fix, 2/120 fix, 1/100 fix, 1/120 fix, 1/250 fix, 1/500 fix, 1/1000 fix, 1/2000 fix, 1/4000 fix, 1/10000 fix

Default: Outdoor scene

Note:

- When a faster shutter speed is selected (up to 1/10000), it is possible to capture a fast moving object with less blur.
 - When a faster shutter speed is selected, the sensitivity will become lower. Smear also may appear under bright light condition.
 - When "On" is selected for "Wide dynamic range", only "Outdoor scene", "Indoor scene (60Hz)" and "Indoor scene (50Hz)" are available.
-

[AGC]

Select a method of gain adjustment from the following.

On(High)/ On(Mid)/ On(Low): When the luminance of the subject becomes darker, gain will be automatically incremented and screen will become brighter. "High", "Mid" and "Low" are indications of gain level.

Off: Images will be captured with the fixed gain level.

Default: On(High)

[Auto slow shutter]

The electronic sensitivity enhancement (sensitivity up) can be carried out by adjusting the storage time of the sensor.

The following are available for the recording duration.

Off(1/30s), Max.2/30s, Max.4/30s, Max.6/30s, Max.10/30s, Max.16/30s

Default: Off(1/30s)

Important:

- When "On" is selected for "Auto slow shutter", frame rate may become lower. Noise or white dots (blemishes) may sometimes appear.
-

Note:

- When "Max.16/30s" is selected, for example, sensitivity will automatically be increased up to x16. When "Off" is selected for "AGC", this setting is unavailable.
-

[Simple Black & white mode]

Select switching between the color mode and the black & white mode from the following.

Off: The color mode is selected.

Auto: Switches from color to black-and-white images when the ambient brightness (illuminance) of the camera is approx.0.2 lx or less.

Default: Off

[White balance]

Select a method of white balance adjustment from the following.

White color can be adjusted by "Red gain" and "Blue gain".

ATW1: Selects the automatic tracing white balance mode. The camera will constantly check the color temperature of the light source and adjust the white balance automatically. Operating color temperature range is approx. 2700 K - 6000 K.

ATW2: Selects the automatic tracing white balance mode under a sodium lamp. The camera will adjust the white balance automatically under a sodium lamp. Operating color temperature range is approx. 2000 K - 6000 K.

AWC: Selects the automatic white balance control mode. This adjustment is suitable for a location where a light source is stable. Operating color temperature range is approx. 2000 K - 10000 K.

Default: ATW1

Note:

- Under the following conditions, color may not be faithfully processed. In these cases, select "AWC".
 - When shooting a subject whose major part is a thick color
 - When shooting blue sky or sun at sunset
 - When shooting a subject whose luminance is too low
- When "AWC" is selected, click the [Set] button.

[Red gain]

Adjust the red color of images.

When the cursor is moved in the "+" direction, the red color will become thicker.

When the cursor is moved in the "-" direction, the red color will be thinner.

Click the [Reset] button to reset the color to the default.

Default: 128

[Blue gain]

Adjust the blue color of images.

When the cursor is moved in the "+" direction, the blue color will become thicker.

When the cursor is moved in the "-" direction, the blue color will be thinner.

Click the [Reset] button to reset the color to the default.

Default: 128

[DNR]

The digital noise reduction function reduces noise automatically under the condition of low illuminance. Select an effect level "High" or "Low" for the digital noise reduction.

High: High DNR, afterimage remains

Low: Low DNR, reduces afterimage

Default: High

[Chroma gain level]

Adjusts the chroma level (color density).

When the cursor is moved in the "+" direction, the colors will become thicker. When the cursor is moved in the "-" direction, the colors will be thinner. Click the [Reset] button to reset the color to the default.

Default: 128

[Aperture level]

Adjust the aperture level (outline compensation).

Images will be sharper when the cursor is moved in the "+" direction, and will be softer when the cursor is moved in the "-" direction.

Click the [Reset] button to reset the color to the default.

Default: 16

[Pedestal level]

Adjust the black level of images by moving the cursor.

When the cursor is moved to the "+" direction, images will become brighter. When the cursor is moved to the "-" direction, images will be darker. Click the [Reset] button to reset the color to the default.

Default: 128

[Close] button

Click this button to quit the "Image adjust" setup menu.

Set mask areas

When "Off" is selected for "Wide dynamic range (WDR)" **SC384**, or "Super Dynamic(SD)" **SW395** **SC385** and "Back light compensation(BLC)", it is possible to compensate for backlight by masking brighter areas.

Step 1

Display the "Image adjust" setup menu. (☞ Page 58)

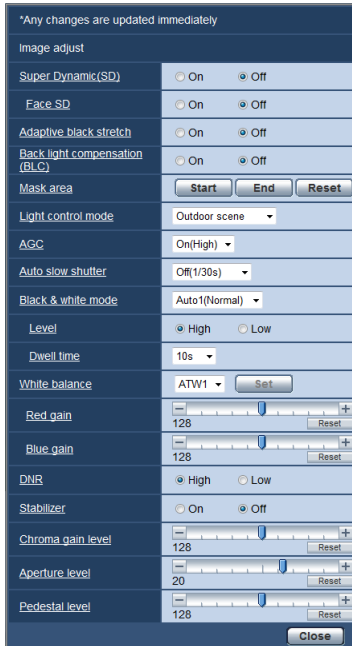

SW395 **SC385**

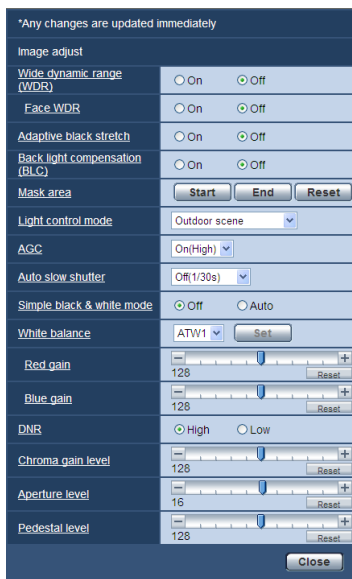

SC384

Step 2

Click the [Start] button of "Mask area".

→ Borders will appear and the image displayed on the [Image/Position] tab will be divided into 48 (6x8).

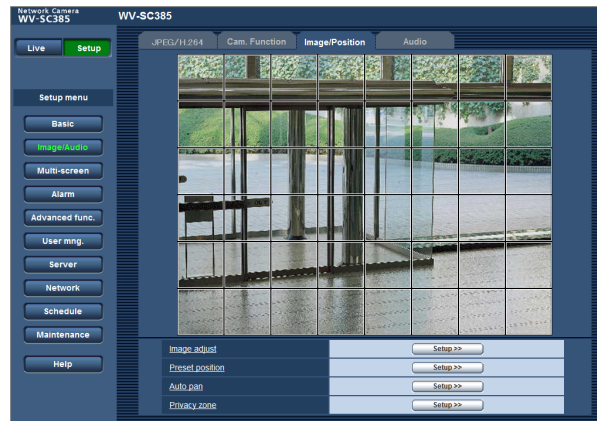

Step 3

Click the divided areas to be masked.

→ The clicked areas will be masked and will become white. To cancel masking, click the area again.

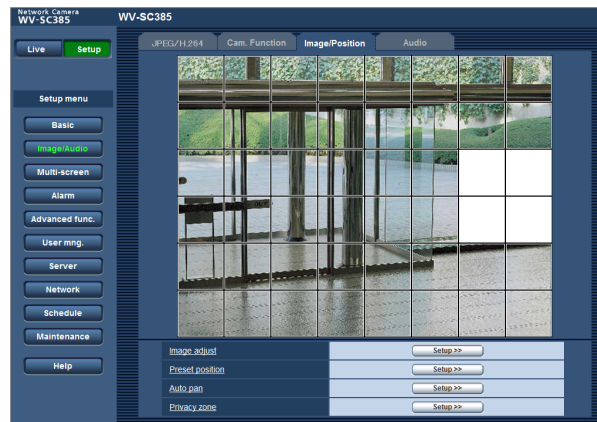

Step 4

Click the [End] button after completing masking areas.

→ The borders on the image displayed on the [Image/Position] tab will disappear.

Important:

- When "16:9" is selected for the aspect ratio of JPEG/H.264, the image will be displayed clipped from the image of "4:3". Therefore even when "16:9" is set, the brightness of the masked area will affect the image. It is recommended that the aspect ratio should be once set to "4:3" before masking.

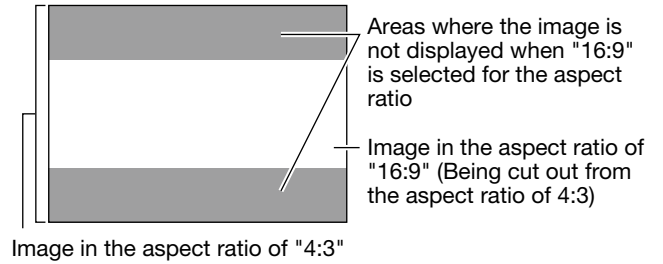

Note:

- When the [Reset] button is clicked, masking for all the masked areas will be canceled.

Configure the settings relating to the preset positions ("Preset position" setup menu)

Click the [Setup>>] button of "Preset position" on the [Image/Position] tab of the "Image/Audio" page (page 58). It is possible to register, edit and delete the preset positions on this page.

When the focus, brightness, zoom factor are adjusted, the adjustment will be applied immediately to the currently displayed image on the [Image/Position] tab.



SW395 SC385

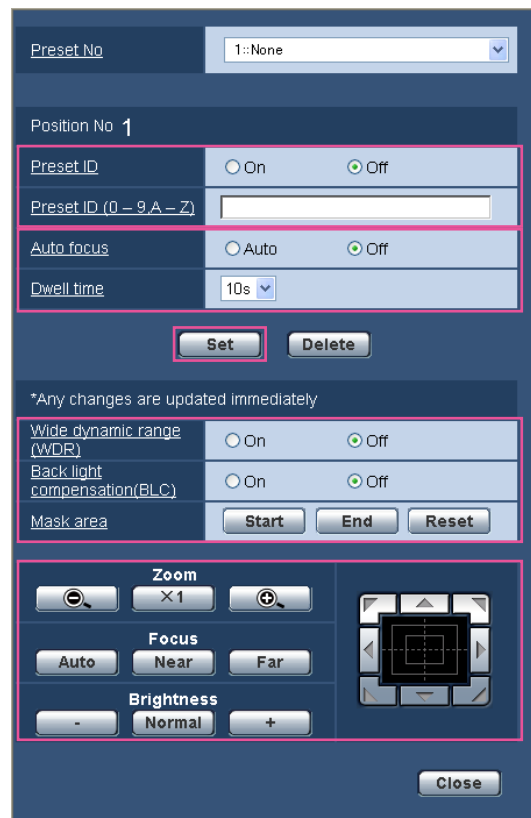

SC384

Important:

- When the zoom factor is 36x or more, the setting of the preset positions will become unavailable.
-

Note:

- Depending on the environment (such as when the temperature is below 5° C (41 °F), for example), the moving speed of the camera to the preset position may become slower.
-

Register the preset positions

Step 1

Select a preset position number.

- The selected preset position number will be displayed in the "Position No" area.
When the selected number has already been registered, the camera will move to the selected preset position.

Step 2

Move the camera to the desired direction.

Step 3

To display the preset ID on the "Live" page, select "On" for "Preset ID" and enter the desired position title to be displayed.

Step 4

The settings for "Auto focus" and "Dwell time" can be configured for each position independently.

Step 5

Click the [Set] button.

Step 6

The settings for each item such as "Super Dynamic" can be configured for each position independently. The settings for "Super Dynamic" (Wide dynamic range **SC384**), "Back light compensation(BLC)" and "Mask area" are updated immediately.

■ Position No

[Preset ID]

Select "On" or "Off" to determine whether to enable or disable the preset ID display. This function can be applied to each preset position.

On: Displays the preset ID.

Off: Does not display the preset ID.

Default: Off

Important:

- When "Preset ID (0-9, A-Z)" or "Preset ID" is configured, it is necessary to click the [Set] button to apply them.
-

Note:

- When "On" is selected, the entered preset ID will be displayed at the position selected for "OSD Position" on the [Basic] tab of the "Basic" page. (Page 31)
-

[Preset ID (0-9, A-Z)]

Enter the preset ID to be displayed on images. This function can be applied to each preset position.

Available characters: 0-9, A-Z and the following marks. ! " # \$ % & ' () * + - , . / ; : = ?

Available number of characters: 0 - 20 characters

Default: None (blank)

Note:

- The entered preset ID will be displayed next to the preset position number on the pull-down menu.
When "On" is selected for "Preset ID", the preset ID will be displayed on images.
-

[Auto focus]

Select "Auto" or "Off" to determine whether to enable or disable the auto focus function after the camera has moved to a preset position. This function can be applied to each preset position.

Auto: The auto focus function will be activated after moving to a preset position.

Off: Does not activate the auto focus function after moving to a preset position.

Default: Off

Note:

- When the preset position is set to shoot the following objects, it is recommended to select "Off", and adjust the focus before registering the preset positions.

An object whose contrast is low

An object whose depth never changes

An object with high luminance such as a spotlight

[Dwell time]

Select a dwell time (duration the camera stops for at each preset position) for the preset sequence operation.

5s/ 10s/ 20s/ 30s

Default: 10s

[Wide dynamic range] **SC384**

Select "On" or "Off" to determine whether or not to activate the wide dynamic range. This function can be applied to each preset position.

On: The wide dynamic function will work.

Off: The wide dynamic function will not work.

Default: Off

[Super Dynamic] **SW395** **SC385**

Select "On" or "Off" to determine whether to turn on or off the Super Dynamic function. This function can be applied to each preset position.

On: The Super Dynamic function will work.

Off: The Super Dynamic function will not work.

Default: Off

[Back light compensation(BLC)]

Select "On" or "Off" to determine whether or not to activate the back light compensation (BLC) function. When "On" is selected for "Super Dynamic" (Wide dynamic range **SC384**), this setting is unavailable. The back light compensation function can compensate back light by setting mask areas on brighter parts of images brighter.

On: Mask areas will be set automatically.

Off: Mask areas will not be set automatically. It is necessary to set them manually.

Default: Off

[Mask area]

When "Off" is selected for "Super Dynamic" (Wide dynamic range **SC384**) and "Back light compensation(BLC)", it is possible to compensate for backlight by masking brighter areas.

Refer to page 66 for descriptions of how to mask.

[Zoom] buttons, [Focus] buttons, [Brightness] buttons, Control pad/buttons

Refer to pages 9 and 11 for descriptions of how to operate these buttons/pad.

[Set] button

Registers the preset positions.

[Delete] button

Deletes the preset position specified by the position number.

[Close] button

Click this button to close the "Preset position" setup menu.

Configure the settings relating to the auto pan function ("Auto pan" setup menu)

Click the [Setup>>] button of "Auto pan" on the [Image/Position] tab of the "Image/Audio" page (page 58). The settings relating to the auto pan function can be configured with the setup menu displayed in a newly displayed window.

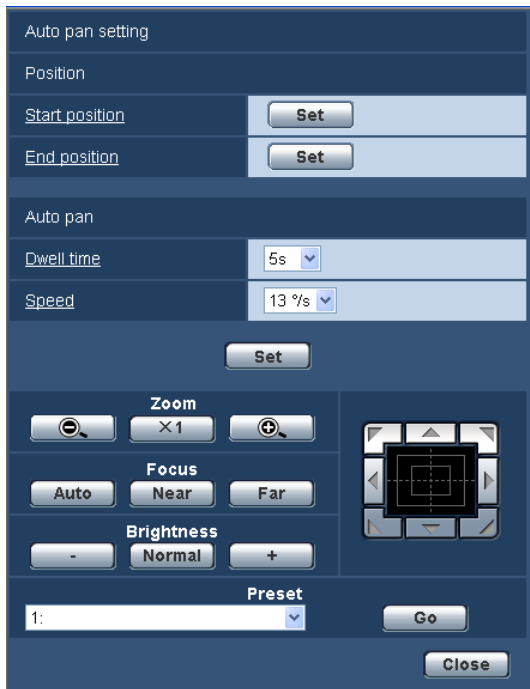

■ Position

[Start position]

Move the camera to the desired point to be set as the start point of the auto panning using the control pad/buttons and adjust the image using the [Zoom] buttons and the [Focus] buttons.

The zoom and focus settings are set together with the start point.

Note:

- Panning, tilting and zooming operations can also be carried out on the [Image/Position] tab.
- Adjusted zoom and focus position for the auto pan function will be applied when [Set] button of "Start position" is clicked.

[End position]

Move the camera to the desired point to be set as the end point of the auto panning using the control pad/buttons, and then click the [Set] button to register the position as the end position.

■ Auto pan

[Dwell time]

Select a dwell time at the start point and the end point from the following.

5s/ 10s/ 20s/ 30s

Default: 5s

[Speed]

Select a speed for the auto panning from the following.

3°/s, 4°/s, 5°/s, 7°/s, 10°/s, 13°/s, 18°/s, 24°/s

Default: 13°/s

Important:

- When "Dwell time" or "Speed" is edited, it is necessary to click the [Set] button to apply them.

Note:

- Even when the selected zoom factor is higher than 36x, the camera will start panning with 36x zoom factor.

[Zoom] buttons, [Focus] buttons, [Brightness] buttons, [Control pad/buttons] and [Go] button

Refer to pages 9 and 11 for descriptions of how to operate these buttons/pad.

[Close] button

Click this button to close the "Auto pan" setup menu.

Configure the settings relating to the privacy zone ("Privacy zone" setup menu)

Click the [Setup>>] button of "Privacy zone" on the [Image/Position] tab of the "Image/Audio" page (☞ page 58). When there is a zone that is not to be displayed, set the zone as a privacy zone to not to display. Up to 8 privacy zones (2 privacy zones (SC384)) can be set.

Note:

- Depending on the panning/tilting direction (especially when the tilting degree is 45° - 90°) and the zooming factor, the area set as the privacy zone may become visible. Make sure that each of the set privacy zone is not visible after setting it.
- The privacy zone function does not work when the camera is in the process of warming-up just after turning on the power, or in the process of refreshing the position.

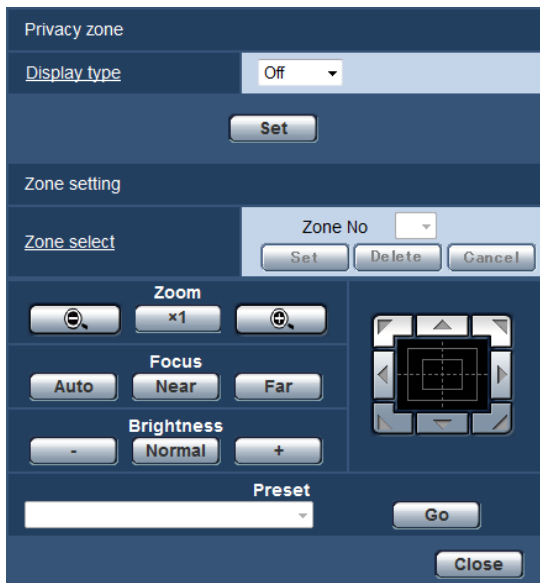

■ Privacy zone

[Display type]

Select a display type of the privacy zone from the following.

Gray: The privacy zones will be displayed in gray.

Mosaic: The privacy zones will be displayed with a mosaic effect. (SW395) (SC385)

Off: Does not display the privacy zones.

Default: Off

■ Zone setting

[Zone select]

Click [▼] of "Zone No" and select a zone number (1-8) (1, 2 (SC384)) from the pull-down menu.

An asterisk (*) next to the zone number indicates that the privacy zone has already been set for the number. A blinking mask will be displayed at the center of the image displayed on the [Image/Position] tab.

Operate the camera with the panning/tilting/zooming operations to cover the area to be covered by the blinking mask.

Click the [Set] button after determining the position of the camera.

To delete the registered zone, click the [Delete] button after designating the desired zone number to be deleted.

Click the [Cancel] button to cancel the application or to delete the setting.

Note:

- Set the privacy zone larger than the size of an object to be hidden.
To raise the precision of the privacy zone placement especially when the zoom is on the "Wide" side, it is recommended to set the privacy zone with the zoom range between 1x and 3x.
- Panning, tilting and zooming operations can also be carried out on the [Image/Position] tab.
- When selecting "Zone No" after selecting "Gray" for "Display type", a mask will be displayed at the center of the image display area and will start blinking while changing its color as follows: Dark gray → Clear → Light gray
When the other mask that had already been set is on the same zone, the mask that had previously been set will blink as follows: Dark gray → Light gray
- When selecting "Zone No" after selecting "Mosaic" for "Display type", a mask will be displayed at the center of the image display area with a mosaic effect.
When the other mask that had already been set is on the same zone, the mask that had previously been set will be displayed in dark gray.

(SW395) (SC385)

[Zoom] buttons, [Focus] buttons, [Brightness] buttons, Control pad/buttons and [Go] button

Refer to pages 9 and 11 for descriptions of how to operate these buttons/pad.

[Close] button

Click this button to close the "Privacy zone" setup menu.

Configure the settings relating to audio [Audio]

Click the [Audio] tab on the "Image/Audio" page. (Pages 26 and 27: How to display/operate the setup menu)
The settings relating to audio can be configured on this page.

Note:

- Images and audio will not be synchronized. Therefore, images and audio may not always match.
- Audio may be interrupted depending on the network environment.

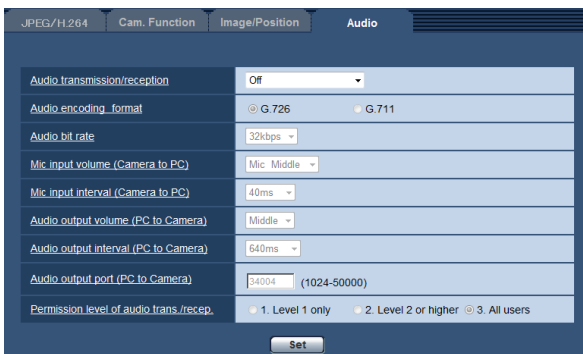

[Audio transmission/reception]

Select the communication mode used for audio data transmission/reception between the camera and the PC from the following.

Off: Does not receive/transmit audio between the camera and the PC. Therefore, the settings and controls relating to audio will be invalidated.

Mic input: The PC receives audio data from the camera. Audio can be heard with images on the PC. Images and audio will not be synchronized.

Audio output: Audio data from the PC will be transmitted to the camera. Audio can be heard from the speaker connected to the camera.

Interactive(Half-duplex): Both reception and transmission are available. However, audio data cannot simultaneously be transmitted and received.

Interactive(Full-duplex): Both reception and transmission are simultaneously available.

Default: Off

Note:

- Howling may be generated depending on usage conditions. If howling is generated, prevent sound generated by the PC from entering the PC microphone.
- When "Multicast" is selected for "Transmission type" on the [JPEG/H.264] (or [JPEG/MPEG-4]) tab of the "Image/Audio" page, audio transmission will become unavailable while monitoring H.264 (or MPEG-4) images. To transmit audio from a PC to the camera, click the [JPEG] button on the "Live" page.

[Audio encoding format]

Select the audio encoding format from G.726 and G.711.

Default: G.726

Note:

- i-PRO Series does not support aspect ratio of "G.711". (As of October, 2010)
- G.711 is available only when "Mic input" is selected for "Audio transmission/reception".

[Audio bit rate]

Select "16kbps" or "32kbps" for the audio bit rate used to transmit/receive audio data.

Default: 32kbps

Note:

- When selecting a smaller value for "Bandwidth control(bit rate)" (page 97) while putting a priority on the JPEG/H.264(MPEG-4) image transmission, select "16kbps" for "Audio bit rate".

- [Audio bit rate] is unavailable when "G.711" is selected for "Audio encoding format".

[Mic input volume (Camera to PC)]

Select a volume level on the PC to hear audio transmitted from the camera.

Mic High: The volume level will become high. This setting will be applied when audio is input to the camera using a microphone.

Mic Middle: The volume level will become middle. This setting will be applied when audio is input to the camera using a microphone.

Mic Low: The volume level will become low. This setting will be applied when audio is input to the camera using a microphone.

Line High: The volume level will become high. This setting will be applied when audio is input to the camera using the Line input.

Line Middle: The volume level will become middle. This setting will be applied when audio is input to the camera using the Line input.

Line Low: The volume level will become low. This setting will be applied when audio is input to the camera using the Line input.

Default: Mic Middle

[Mic input interval (Camera to PC)]

Select an interval for audio reception from the following.
20ms/ 40ms/ 80ms/ 160ms

Default: 40ms

Note:

- When a shorter interval is selected, the delay time will be shorter. When a longer interval is selected, audio interruption may be diminished even though the delay time will be longer. Select the interval according to the network environment.

[Audio output volume (PC to Camera)]

Select a volume level on the camera to hear audio transmitted from the PC.

High/ Middle/ Low

Default: Middle

[Audio output interval (PC to Camera)]

Select an interval for audio transmission from the following.

160ms/ 320ms/ 640ms/ 1280ms

Default: 640ms

Note:

- When a shorter interval is selected, the delay time will be shorter. When a longer interval is selected, audio interruption may be diminished even though the delay time will be longer. Select the interval according to the network environment.
- Audio may temporarily be interrupted or noise may be heard the camera, or when multiple users are accessing concurrently. It may be possible to diminish the interruption or noise by setting a longer interval for "Audio output interval (PC to Camera)".
- Audio may sometimes not be heard depending on the network environment.

[Audio output port (PC to Camera)]

Enter the transmission port number (the port number on the camera used to receive audio data transmitted from the PC).

Available port number: 1024-50000 (Only even numbers are available.)

Default: 34004

Note:

- The transmission port number entered for "Audio output port (PC to Camera)" will be used only when "Unicast port (MANUAL)" is selected for "Transmission type" (☞ page 51 and 55). When "Off" is selected for "H.264 transmission" (or "MPEG-4 transmission") (☞ pages 49 and 53) or when "Unicast port (AUTO)" or "Multicast" is selected for "Transmission type", it is not necessary to enter the transmission port number.

[Permission level of audio trans./recep.]

Select an access level for audio transmission/reception from the following.

1. Level 1 only/ 2. Level 2 or higher/ 3. All users

Default: 3. All users

Note:

- Refer to pages 87 and 88 for further information about the access level.

Configure the multi-screen settings [Multi-screen]

The cameras from which images are to be displayed on a multi-screen can be registered on the "Multi-screen" page. (☞ Pages 26 and 27: How to display/operate the setup menu)

Group A	IP address	Camera title
Cam. 1	<input type="text"/>	<input type="text"/>
Cam. 2	<input type="text"/>	<input type="text"/>
Cam. 3	<input type="text"/>	<input type="text"/>
Cam. 4	<input type="text"/>	<input type="text"/>

Group B	IP address	Camera title
Cam. 5	<input type="text"/>	<input type="text"/>
Cam. 6	<input type="text"/>	<input type="text"/>
Cam. 7	<input type="text"/>	<input type="text"/>
Cam. 8	<input type="text"/>	<input type="text"/>

Group C	IP address	Camera title
Cam. 9	<input type="text"/>	<input type="text"/>
Cam. 10	<input type="text"/>	<input type="text"/>
Cam. 11	<input type="text"/>	<input type="text"/>
Cam. 12	<input type="text"/>	<input type="text"/>

Group D	IP address	Camera title
Cam. 13	<input type="text"/>	<input type="text"/>
Cam. 14	<input type="text"/>	<input type="text"/>
Cam. 15	<input type="text"/>	<input type="text"/>
Cam. 16	<input type="text"/>	<input type="text"/>

Note:

- When using the host name, it is necessary to configure the DNS settings of the PC to be used for the multi-screen display. (☞ Page 94)

[Camera title]

Enter the title of the camera. The entered camera title will be displayed on a multi-screen.

Available number of characters: 0 - 20 characters

Unavailable characters: "&"

Note:

- When selecting a 16 split-screen, some characters of the camera title to be displayed may not be displayed.
- Even when "16:9" is selected for "Aspect ratio", the multi-screen is displayed in 4:3.

[IP address]

Enter the IP address or the host name of the camera to be used for the multi-screen. 4 cameras can be registered as a group and up to 4 groups (16 cameras) can be registered.

When the HTTP port number for the camera of which images are to be displayed had been changed, enter as follows:

Example of entry:

Example when entering an IPv4 address:

http://192.168.0.10:8080

Example when entering an IPv6 address:

http://[2001:db8:0:0:0:0:1]:8080

Available number of characters: 1 - 128 characters

To access the cameras using the HTTPS protocol, enter as follows:

Example of entry: https://192.168.0.10/

Important:

- When accessing the camera using the HTTPS protocol, install the security certificate of the camera to display images on the monitor. (☞ Page 106)

Configure the alarm settings [Alarm]

The settings relating to alarm occurrences such as settings for the alarm action at an alarm occurrence, the VMD area settings, and the alarm occurrence notification can be configured on this page.

The "Alarm" page has 3 tabs; the [Alarm] tab, the [VMD area] tab and the [Notification] tab.

Configure the settings relating to the alarm action [Alarm]

Click the [Alarm] tab on the "Alarm" page. (☞ Pages 26 and 27: How to display/operate the setup menu)

The settings relating to the alarm can be configured in this section. Refer to pages 77 and 79 for further information about the settings relating to the alarm images and the alarm output terminal.

Alarm	
Terminal 1	Off
Terminal 2	Off
Terminal 3	Off
VMD alarm	VMD >>
Command alarm	<input checked="" type="radio"/> On <input type="radio"/> Off
Originating port number	8181 (1-65535)

Set

■ Alarm

[Terminal 1]

Determine how to use terminal 1.

Off: Not used.

Alarm input: Receives alarms.

Black & white input: Receives the black & white switchover input. (When the input is set to On, the black & white mode is activated.) **SW395** **SC385**

Default: Off

[Terminal 2]

Determine how to use terminal 2.

Off: Not used.

Alarm input: Receives alarms.

Alarm output: Alarm output will be carried out according to the settings for "Alarm output terminal setup" (☞ page 79).

Default: Off

[Terminal 3]

Determine how to use terminal 3.

Off: Not used.

Alarm input: Receives alarms.

AUX output: AUX output will be supplied. The [AUX] buttons will be displayed on the "Live" page.

Default: Off

Note:

- AUX is a camera terminal that allows users to operate (Open/Close) arbitrarily from the "Live" page. For example, an operator can remotely control lights in a place where the camera is installed by connecting the terminal to the light controller.
- Refer to the installation guide for further information about input/output rating of each terminal.
- While "Alarm input" is being selected, an alarm is detected when the terminal status is changed to "On". (Default)

It is possible to configure the setting so that an alarm is detected when the terminal status is changed to "Off". Refer to the "Readme" file on the provided CD-ROM for further information about the setting. Or refer to our website (<http://panasonic.net/pss/security/support/info.html>) for further information about the supported software.

[VMD alarm]

When clicking "VMD >>", the [VMD area] tab of the "Alarm" page will be displayed.

[Command alarm]

Select "On" or "Off" to determine whether or not to receive the command alarm.

The command alarm is the function that provides notification of a Panasonic protocol alarm from the other cameras. When "On" is selected, alarm actions will be performed between multiple cameras.

Default: Off

[Originating port number]

Select a port number to be used to receive the command alarm.

Available range: 1-65535

Unavailable port number: Refer to the help window.

Default: 8181

Configure the settings relating to the camera action on alarm occurrence [Alarm]

Click the [Alarm] tab on the "Alarm" page. (☞ Pages 26 and 27: How to display/operate the setup menu)

The settings relating to the camera action at an alarm occurrence can be configured in this section. Refer to pages 75, 77 and 79 for further information about the settings relating to the alarm, the alarm image and the alarm output terminal.

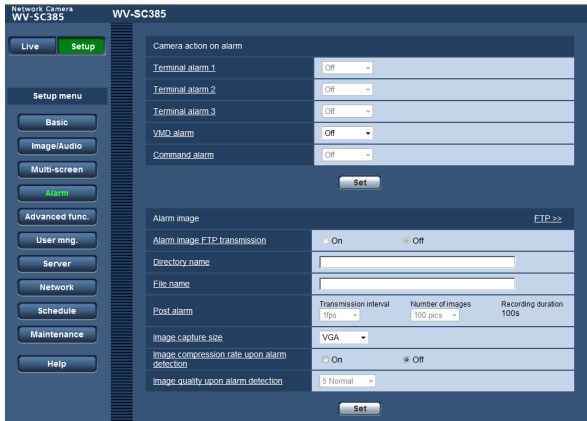

■ Camera action on alarm

[Terminal alarm 1]

Select an action to be taken when a terminal alarm 1 is detected from the following.

Off: Does not take any action even when a terminal alarm 1 is detected.

1-64: When the registered preset position is selected, the camera will move to the selected preset position when a terminal alarm 1 is detected.

Auto track **SW395** **SC385** : When a terminal alarm 1 is detected, the camera will start the auto tracking.

Default: Off

[Terminal alarm 2]

Select an action to be taken when a terminal alarm 2 is detected from the following.

Off: Does not take any action even when a terminal alarm 2 is detected.

1-64: When the registered preset position is selected, the camera will move to the selected preset position when a terminal alarm 2 is detected.

Auto track **SW395** **SC385** : When a terminal alarm 2 is detected, the camera will start the auto tracking.

Default: Off

[Terminal alarm 3]

Select an action to be taken when a terminal alarm 3 is detected from the following.

Off: Does not take any action even when a terminal alarm 3 is detected.

1-64: When the registered preset position is selected, the camera will move to the selected preset position when a terminal alarm 3 is detected.

Auto track **SW395** **SC385** : When a terminal alarm 3 is detected, the camera will start the auto tracking.

Default: Off

[VMD alarm]

Select an action to be taken when a VMD alarm is detected from the following.

Off: Does not take any action even when a VMD alarm is detected.

1-64: When the registered preset position is selected, the camera will move to the selected preset position when a VMD alarm is detected.

Auto track **SW395** **SC385** : When a VMD alarm is detected, the camera will start the auto tracking.

Default: Off

[Command alarm]

Select an action to be taken when a command alarm is detected from the following.

Off: Does not take any action even when a command alarm is detected.

1-64: When the registered preset position is selected, the camera will move to the selected preset position when a command alarm is detected.

Auto track **SW395** **SC385** : When a command alarm is detected, the camera will start the auto tracking.

Default: Off

Configure the settings relating to the alarm image [Alarm]

Click the [Alarm] tab on the "Alarm" page. (☞ Pages 26 and 27: How to display/operate the setup menu)
The settings relating to the alarm image to be transmitted to an FTP server can be configured in this section. The alarm image will be transmitted to an FTP server. To transmit alarm images to an FTP server, it is necessary to configure the settings in advance. (☞ Page 91)

Important:

- Depending on the network line speed or the network traffic, images may not be transmitted at the exact designated interval or period.
- When "Alarm input" or "Manual" is selected for "Save trigger" on the [SD memory card] tab, images will not be transmitted to the FTP server even when an alarm is detected. (☞ Page 34)

Alarm image FTP transmission	<input type="radio"/> On <input checked="" type="radio"/> Off
Directory name	<input type="text"/>
File name	<input type="text"/>
Post alarm	Transmission interval: 1fps, Number of images: 100 pics, Recording duration: 100s
Image capture size	VGA
Image compression rate upon alarm detection	<input type="radio"/> On <input checked="" type="radio"/> Off
Image quality upon alarm detection	5 Normal

Set

■ Alarm image

[FTP >>]

When "FTP >>" is clicked, the [FTP] tab of the "Server" page will be displayed. (☞ Page 91)

[Alarm image FTP transmission]

Select "On" or "Off" to determine whether or not to transmit the alarm image to the FTP server.

Default: Off

[Directory name]

Enter the directory name where the alarm images are to be saved.

For example, enter "/ALARM" to designate the directory "ALARM" under the root directory of the FTP server.

Available number of characters: 1 - 256 characters

[File name]

Enter the file name used for the alarm image to be transmitted to an FTP server. The file name will be as follows.

File name: ["Entered file name" + "Time and date (year/ month/ day/ hour/ minute/ second)"] + "Serial number"

Available number of characters: 1 - 32 characters

[Post alarm]

• Transmission interval

Select the transmission interval for the alarm image transmission to the FTP server from the following.

0.1fps/ 0.2fps/ 0.33fps/ 0.5fps/ 1fps

Default: 1fps

• Number of images

Select the number of images to be transmitted from the following.

1pic/ 2pics/ 3pics/ 4pics/ 5pics/ 6pics/ 7pics/ 8pics/ 9pics/ 10pics/ 20pics/ 30pics/ 50pics/ 100pics/ 200pics/ 300pics/ 500pics/ 1000pics/ 2000pics/ 3000pics

Default: 100pics

• Recording duration

Approximate time to be taken to save the set "Number of images" with the set "Transmission interval" will be displayed.

[Image capture size]

Select the capture size of images to be transmitted to the FTP server or of an image to be attached to the alarm mail.

When "4:3(VGA)" is selected for "Aspect ratio"

QVGA/ VGA/ 1280x960

When "4:3(800x600)" is selected for "Aspect ratio"

SW395 **SC385**

QVGA/ 800x600/ 1280x960

When "16:9" is selected for "Aspect ratio"

320x180/ 640x360/ 1280x720

Default: VGA

[Image compression rate upon alarm detection]

Select "On" or "Off" to determine whether or not to change the image quality of the quality 1 upon alarm detection.

On: Images will be transmitted with the image quality selected for "Image quality upon alarm detection".

Off: Does not change the image quality upon alarm detection.

Default: Off

[Image quality upon alarm detection]

Image quality can be changed upon an alarm occurrence. Select the image quality from the following.

0 Super fine/ 1 Fine/ 2/ 3/ 4/ 5 Normal/ 6/ 7/ 8/ 9 Low

Default: 5 Normal

Configure the settings relating to H.264 recording [Alarm]

Click the [Alarm] tab on the "Alarm" page. (☞ Pages 26 and 27: How to display/operate the setup menu)

The settings relating to the recording H.264 data on the SD memory card when an alarm is detected can be configured on this page. To operate recording, it is necessary to configure the settings relating to SD memory card and the moving picture data. (☞ Page 33)

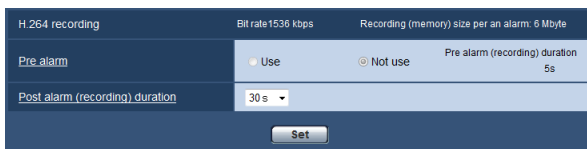

■ H.264 recording

[Pre alarm]

Determine whether or not to perform the pre-alarm recording. When "Use" is selected, 1 MB image data is always saved during the pre alarm recording.

Use/ Not use

Default: Not use

[Post alarm (recording) duration]

Set the duration to save image data on the SD memory card after an alarm occurrence.

10s/ 20s/ 30s/ 40s/ 50s/ 60s/ 120s/ 180s/ 240s/ 300s

Default: 30s

- * The actual recording time may sometimes be longer than the duration selected for this setting.

[Recording (memory) Size per an alarm]

The capacity of the SD memory card used to record video data upon an alarm occurrence. The actual capacity may be different.

Important:

- To record H.264 data, it is required to select "Use" for "SD memory card" on the [SD memory card] tab. In addition, it is select "H.264" for "Recording format". (☞ Page 33)
-

Configure the settings relating to the alarm output terminal

[Alarm]

Click the [Alarm] tab on the "Alarm" page. (☞ Pages 26 and 27: How to display/operate the setup menu)
The settings relating to the alarm output terminal can be configured in this section.

Alarm output terminal setup	
Alarm output trigger	<input type="radio"/> On <input type="radio"/> Off
Alarm output type	<input type="radio"/> Latch <input type="radio"/> Pulse
Trigger output	<input type="radio"/> Open <input type="radio"/> Close
Pulse width	<input type="text"/> s (1-120s)

[Pulse width]

When "Pulse" is selected for "Alarm output", select an alarm output terminal duration from the following.

Available range: 1-120s

Default: 1s

■ Alarm output terminal setup

[Alarm output trigger]

Select "On" or "Off" to determine whether or not to output the alarm signals to the alarm output terminal when an alarm is detected.

Default: Off

[Alarm output type]

Select "Latch" or "Pulse" for the alarm output terminal at an alarm occurrence.

Latch: When an alarm is detected, the alarm output terminal will be in the state selected for "Trigger output" until the alarm occurrence indication button is clicked.

Pulse: When an alarm is detected, the alarm output terminal will be in the state to the "Trigger output" setting for the period set for "Pulse width". When the alarm occurrence indication button is clicked, the alarm output terminal will return to the normal state.

Default: Latch

[Trigger output]

Select "Open" or "Close" to determine whether to open or close the alarm output terminal when outputting the alarm signals.

Open: The alarm output terminal will open when outputting the alarm signals. (Normally close)

Close: The alarm output terminal will close when outputting the alarm signals. (Normally open)

Default: Close

Note:

- When "Open" is selected, the alarm signal will be output for around 20 seconds when the power of the unit is turned on.
-

Change the AUX name [Alarm]

Click the [Alarm] tab on the "Alarm" page. (☞ Pages 26 and 27: How to display/operate the setup menu)
The names of "AUX", "Open" and "Close" on the "Live" page can be changed.

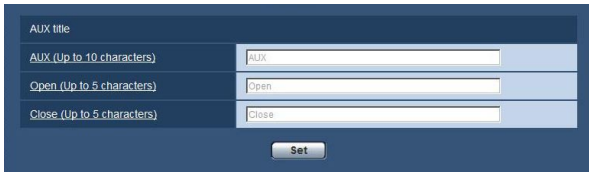

The screenshot shows a configuration window with a dark blue header and a light blue background. It contains three input fields with labels and a 'Set' button at the bottom. The first field is labeled 'AUX title' and contains the text 'AUX'. The second field is labeled 'Open (Up to 5 characters)' and contains the text 'Open'. The third field is labeled 'Close (Up to 5 characters)' and contains the text 'Close'.

■ AUX title

[AUX (Up to 10 characters)]

Enter the name for "AUX" on the "Live" page.

Default: AUX

[Open (Up to 5 characters)]

Enter the name for "Open" of "AUX" on the "Live" page.

Default: Open

[Close (Up to 5 characters)]

Enter the name for "Close" of "AUX" on the "Live" page.

Default: Close

Note:

- AUX is a camera terminal that allows users to operate (Open/Close) arbitrarily from the "Live" page. For example, an operator can remotely control lights in a place where the camera is installed by connecting the terminal to the light controller.
-

Configure the VMD settings [VMD area]

Click the [VMD area] tab on the "Alarm" page. (☞ Pages 26 and 27: How to display/operate the setup menu)
The video motion detection areas can be set on this page.

The VMD areas can be set for each preset position (up to 4 areas, 64 preset positions). When motion is detected in the set area, it will be regarded as an alarm. The camera can be configured to take an alarm action even when the camera is not at the preset position.

Important:

- The alarm occurrence indication button (☞ page 11) will be displayed when motion is detected by the VMD function.
 - The alarm occurrence indication button will be displayed when receiving an alarm input of a terminal alarm or a command alarm.
 - Depending on the network environment, notification may be delayed even when "Real time" is selected for "Alarm status update mode" on the [Basic] tab of the "Basic" page (☞ page 32).
 - The motion detection function is not the dedicated function to prevent thefts, fires, etc. We are not responsible for any accidents or damages occurring in case.
-

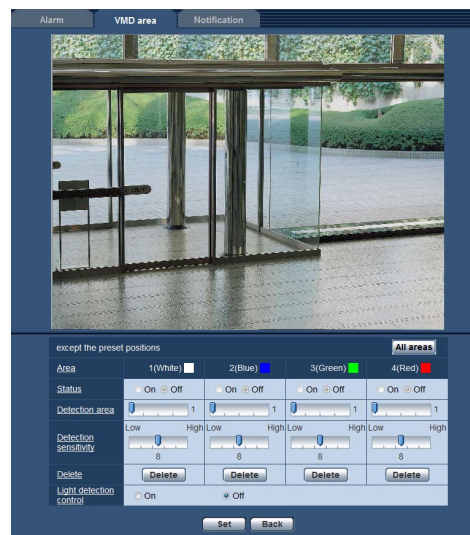
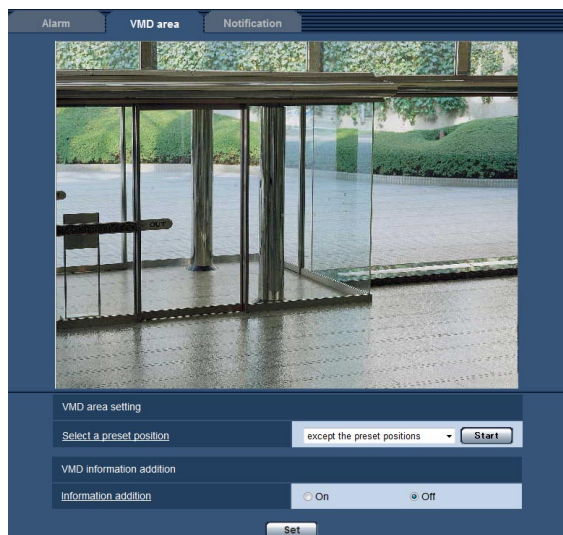

■ VMD area setting

[Select a preset position]

Select a preset position number to which the VMD area is to be set, and click the [Start] button. (Page 82)

When setting an area which is not at the preset position for the VMD area, select VMD activation in area "except the preset positions".

[Area]

When selecting a VMD area in the screen, it will be numbered as area 1. (Subsequent areas will be numbered in the order of selection.)

[All areas] button

When the [All areas] button is clicked, the whole area will become the VMD area, and "1 (White)" will be automatically applied to "Area".

[Status]

Select "On" or "Off" to determine whether or not to activate each VMD area.

On: Activates the respective VMD area.

Off: Inactivates the respective VMD area.

Default: Off

[Detection area]

Adjust the size of the VMD area using the slider. The smaller the selected value is, the higher the sensitivity of VMD area becomes. The current value (1-10) will be displayed on the right of the slider.

Default: 1

[Detection sensitivity]

Adjust the sensitivity of motion detection in the VMD

area using the slider. The settings can be configured for each area individually. The larger the value is set, the higher the sensitivity level becomes.

The current value (1 (low) - 15 (high)) will be displayed below the slider.

Default: 8

[Delete] button

Click the [Delete] button corresponding to the area to be deleted. The outline of the selected area will be deleted.

[Light detection control]

Select "On" or "Off" to determine whether or not to detect video motion affected by brightness change such by a dimming level control.

Default: Off

Important:

- "Light detection control" may not work when brightness change is too small.
 - When "On" is selected for "Light detection control", the video motion detection may not be performed even when detecting a subject moving over the whole screen.
-

■ VMD information addition

[Information addition]

Select "On" or "Off" to determine whether or not to add VMD information to superimposed image data.

The VMD information can be searched by some Panasonic network disk recorders. Refer to the operating instructions of the connected devices for further information about the functions and settings.

Default: Off

Set the VMD areas [VMD area]

Set the areas to activate the VMD function.

Important:

- When the settings are being configured on the setup menu, sometimes the VMD function may not work correctly.

Step 1

Set the video motion detection area by dragging the mouse on the screen.

When the [All areas] button is clicked, the whole area will become the VMD area, and "1 (White)" will be automatically applied to "Area".

- The designated area will become the VMD area "1(White)" and the outline will be displayed. When 2 - 4 VMD areas are set, each area will be numbered in order. The areas will be identified by the respective outline colors. The "Status" of the outline to be set for the area will become "On".

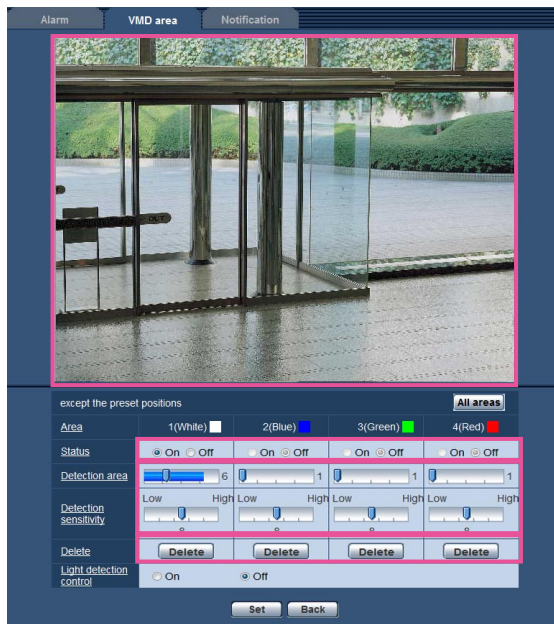

Step 2

Adjust "Detection area" and "Detection sensitivity" using the slider.

"Detection area" can be adjusted by moving the slider between the left end position and the center position.

"Detection sensitivity" can be adjusted by moving the slider between the left end position and the right end position.

Refer to page 81 for further information about the "Detection sensitivity" and "Detection area".

The status bar will be indicated in the "Detection area" section to show the motion detection status of the currently displayed area.

When the status bar exceeds the setting position of slider, the alarm action will be performed.

Note:

- When "Detection area" cannot be adjusted properly by moving the slider, adjust "Detection sensitivity" while checking the motion detection status.

Step 3

Click the [Set] button after completing the settings.

Important:

- The setting will not be applied unless the [Set] button is clicked.

Step 4

To invalidate the VMD area, click the [Set] button after selecting "Off" for "Status" of the VMD area to be invalidated.

- The outline of the invalidated VMD area will turn to a dotted line. When the VMD area is invalidated, no alarm will occur even when a motion can be recognized in the area.

Step 5

To delete the VMD area, click the [Delete] button corresponding to the area to be deleted.

- The outline of the respective VMD area will disappear.

Step 6

Click the [Set] button.

- The edited settings will be applied.

Step 7

Click the [Back] button to return to the screen to select a preset position.

Configuration of the settings relating to the mail notification

[Notification]

Click the [Notification] tab on the "Alarm" page. (☞ Pages 26 and 27: How to display/operate the setup menu)
The settings relating to the alarm mail can be configured. It is necessary to configure the settings of the mail server to perform the mail notification. (☞ Page 90)

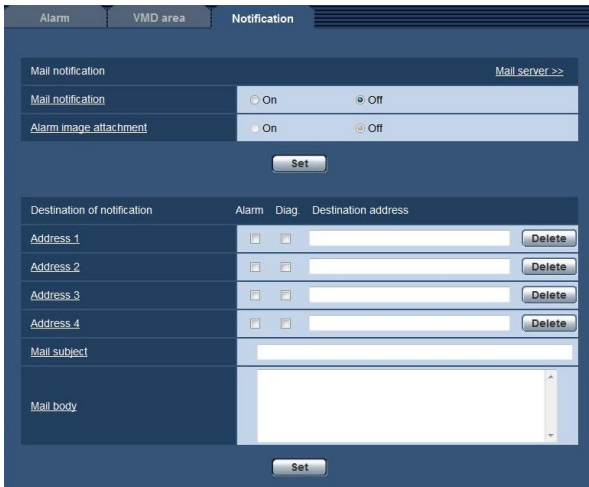

■ Mail notification

[Mail server >>]

When "Mail server >>" is clicked, the [Mail] tab of the "Server" page will be displayed. (☞ Page 90)

[Mail notification]

Select "On" or "Off" to determine whether or not to provide notification by e-mail according to the settings for the "Alarm" and "Diag." checkboxes of "Destination of notification" below.

- When an alarm is detected ("Alarm")
- When a notification of the remaining capacity of the SD memory card has been provided ("Diag.")
- When the SD memory card has become full ("Diag.")
- When the SD memory card cannot be recognized ("Diag.")

Default: Off

[Alarm image attachment]

Select "On" or "Off" to determine whether or not to attach an image to the mail to be sent when an alarm is detected.

Default: Off

Note:

- The settings for "Image capture size" of the "Alarm image" section on the [Alarm] tab (☞ page 77) will be applied to the size of the image to be attached.

■ Destination of notification

[Address 1] - [Address 4]

Enter the destination mail address. Up to 4 destination addresses can be registered.

"Alarm" checkbox: When the checkbox is checked, the mail notification will be performed upon an alarm occurrence.

"Diag." checkbox: When the checkbox is checked, the mail notification will be provided in the following cases.

- When notification of the remaining capacity of the SD memory card has been provided
- When the SD memory card has become full
- When the SD memory card cannot be recognized

"Destination address": Enter the destination address.

Available number of characters: 3 - 128 characters

To delete the registered address, click the [Delete] button respective to the desired address.

[Mail subject]

Enter the mail subject.

Available number of characters: 0 - 50 characters

[Mail body]

Enter the mail body.

Available number of characters: 0 - 200 characters

Note:

- Notification mail will be sent with the message "The capacity of the SD memory card is full." when the SD memory card becomes full, or "The SD memory card cannot be detected." when mounting of the SD memory card failed.

Configure the settings relating to Panasonic alarm protocol [Notification]

Click the [Notification] tab on the "Alarm" page. (☞ Pages 26 and 27: How to display/operate the setup menu)
The settings relating to Panasonic alarm protocol can be configured in this section.

Destination of notification	Alarm	Diag.	Destination IP address
Address 1	<input type="checkbox"/>	<input type="checkbox"/>	<input type="text"/> <input type="button" value="Delete"/>
Address 2	<input type="checkbox"/>	<input type="checkbox"/>	<input type="text"/> <input type="button" value="Delete"/>
Address 3	<input type="checkbox"/>	<input type="checkbox"/>	<input type="text"/> <input type="button" value="Delete"/>
Address 4	<input type="checkbox"/>	<input type="checkbox"/>	<input type="text"/> <input type="button" value="Delete"/>
Address 5	<input type="checkbox"/>	<input type="checkbox"/>	<input type="text"/> <input type="button" value="Delete"/>
Address 6	<input type="checkbox"/>	<input type="checkbox"/>	<input type="text"/> <input type="button" value="Delete"/>
Address 7	<input type="checkbox"/>	<input type="checkbox"/>	<input type="text"/> <input type="button" value="Delete"/>
Address 8	<input type="checkbox"/>	<input type="checkbox"/>	<input type="text"/> <input type="button" value="Delete"/>

■ Panasonic alarm protocol notification

[Panasonic alarm protocol]

Select "On" or "Off" to determine whether or not to provide notification by Panasonic alarm protocol according to the settings for the "Alarm" and "Diag." checkboxes of "Destination of notification" below.

- When an alarm is detected ("Alarm")
- When a notification of the remaining capacity of the SD memory card has been provided ("Diag.")
- When the SD memory card has become full ("Diag.")
- When the SD memory card cannot be recognized ("Diag.")

Default: Off

Note:

- When "On" is selected, notification of the alarm occurrence will be provided to the registered destination addresses in order (to IP address 1 first, to IP address 8 last).

[Destination port]

Select a destination port for the Panasonic alarm protocol from the following.

Available range: 1 - 65535

Unavailable port number: Refer to the help window.

Default: 1818

[Retry times]

Select a retry time for the Panasonic alarm protocol.

Available range: 0-30

Default: 2

■ Destination of notification

[Address 1] - [Address 8]

Enter the destination IP address of the Panasonic alarm protocol from the following. Host name is unavailable for the IP address. Up to 8 destination addresses can be registered.

"Alarm" checkbox: When the checkbox is checked, the Panasonic alarm notification will be provided upon an alarm occurrence.

"Diag." checkbox: When the checkbox is checked, notification using Panasonic alarm protocol will be provided in the following cases.

- When notification of the remaining capacity of the SD memory card has been provided
- When the SD memory card has become full
- The SD memory card cannot be recognized

"Destination IP address": Enter the destination address.

To delete the registered IP address, click the [Delete] button respective to the desired IP address.

Important:

- Confirm that the destination IP addresses are registered correctly. When a registered destination does not exist, notification may be delayed.

Configure the setting relating to the image recognition [Advanced func.]

The setting relating to the XML notification, destinations of information about the face detection and the settings relating to the face detection can be configure on the "Advanced func." page.

The "Advanced func." page has 2 tabs; the [XML notification] tab and the [Face detection] tab.

Configure the settings relating to the XML notification [XML notification]

Click the [XML notification] tab on the "Advanced func." page.

The settings relating to the XML notification can be configured in this section.

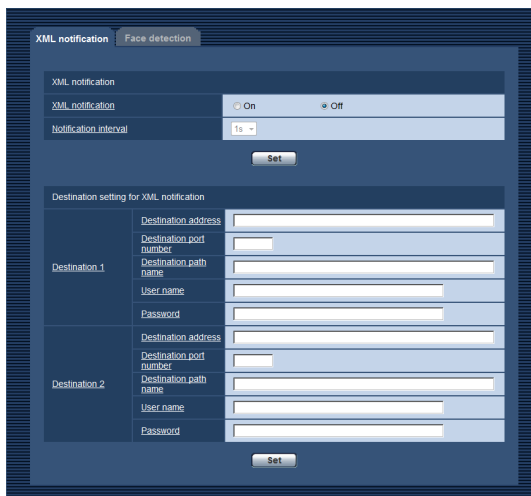

■ XML notification

[XML notification]

Select "On" or "Off" to determine whether or not to notify face detection information using XML.

Default: Off

[Notification interval]

Select "1s" or "2s" for the notification interval.

Default: 1s

Configuration of the destination settings of the face detection [XML notification]

Click the [XML notification] tab on the "Advanced func." page.

The destination settings of the face detection information can be configured.

The XML notification notifies the server of face detection information in XML format.

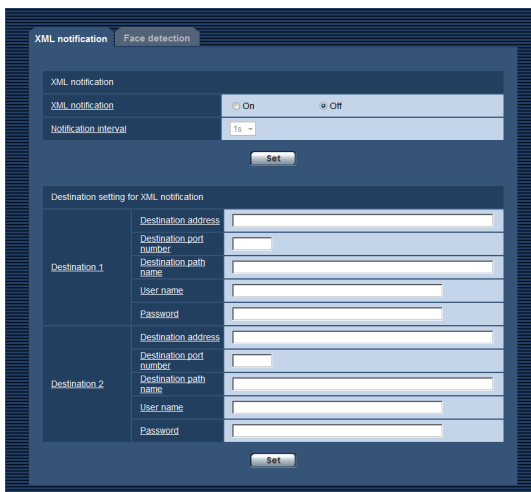

■ Destination setting for XML notification

[Destination address]

Configure the IP address or the host name of the destination for XML notification of the face detection information.

Available number of characters: 1 - 128 characters

[Destination port number]

Configure the port number settings for XML notification of the face detection information.

Refer to the help window for information about the unavailable port number.

[Destination path name]

Configure the settings for the destination directory to be used for the XML notification of the face detection.

[User name]

Enter a user name.

Available number of characters: 0 - 32 characters

Default: None (blank)

[Password]

Enter a password.

Available number of characters: 0 - 32 characters

Default: None (blank)

Configuration of the settings relating to the face detection

[Face detection]

Click the [Face detection] tab on the "Advanced func." page.

The settings relating to displaying the frame to be used for the face detection and the settings relating to the face detection information attached to the image can be configured.

Important:

- The face detection function shall not guarantee the detection of faces in an image. The face detection accuracy varies with imaging conditions.

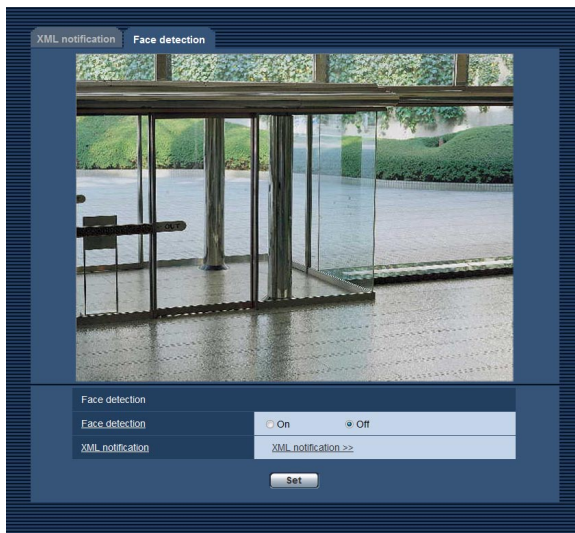
**Important:**

- When "Mosaic" is selected for "Display type" of "Privacy zone", the face detection function may sometimes be triggered (the face detection frame will be displayed). **SW395** **SC385**

[XML notification]

The destination settings of the face detection information can be configured.

When clicking "XML notification >>", the [XML notification] tab will be displayed. (☞ Page 85)

■ Face detection

[Face detection]

Determine whether or not to enable the face detection function.

On: Information about the face detection frame will be attached and the test frame will be displayed on the image of this page.

Off: Information about the face detection frame will not be attached. No face detection frame will be displayed on the image of this page.

Default: Off

Configure the settings relating to the authentication [User mng.]

The settings relating to the authentication such as users and PCs restrictions for accessing the camera can be configured on the "User mng." page.

The "User mng." page has 3 tabs; the [User auth.] tab, the [Host auth.] tab and the [System] tab.

Configure the settings relating to the user authentication [User auth.]

Click the [User auth.] tab on the "User mng." page. (☞ Pages 26 and 27: How to display/operate the setup menu)

The settings relating to the authentication of users who can access this camera from the PC or a cellular phone can be configured on this page. Up to 18 users can be registered.

Note:

- When user authentication (authentication error) has failed to pass 8 times within 30 seconds using the same IP address (PC), access to the unit will be denied for a while.

[User auth.]

Select "On" or "Off" to determine whether or not to authenticate the users.

Default: Off

[User name]

Enter a user name.

Available number of characters: 1 - 32 characters

Default: None (blank)

[Password] [Retype password]

Enter a password.

Available number of characters: 4 - 32 characters

Default: None (blank)

Note:

- When the user name already in use is entered and the [Set] button is clicked, the respective user information will be overwritten.

[Access level]

Select the access level of the user from the following.

- 1. Administrator:** Allowed all available operations of the camera.
- 2. Camera control:** Allowed to display images from the camera and to control the camera. The camera setting configuration is unavailable.
- 3. Live only:** Only displaying live images is available. The camera setting configuration and camera control are unavailable.

Default: 3. Live only

[User check]

By clicking [▼] of "User check", the registered user can be selected and the selected user's information can be checked.

The registered user will be displayed with the access level.

(Example: admin [1])

To delete the registered user, click the [Delete] button after selecting the user to be deleted.

Configure the settings relating to the host authentication

[Host auth.]

Click the [Host auth.] tab on the "User mng." page. (☞ Pages 26 and 27: How to display/operate the setup menu)
The restriction settings of PCs (IP address) from accessing the camera can be configured on this page.

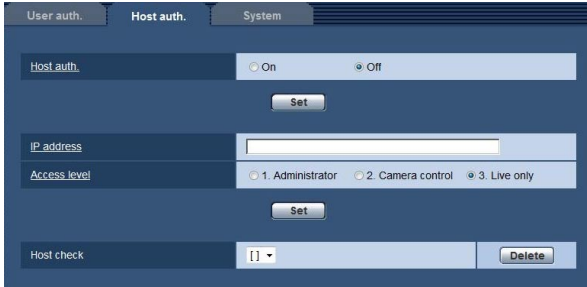

[Host check]

By clicking [▼] of "Host check", the registered host can be selected and the selected host's IP address can be checked.

The registered IP address will be displayed with the access level.

(Example: 192.168.0.21 [1])

To delete the registered host, click the [Delete] button after selecting the IP address to be deleted.

[Host auth.]

Select "On" or "Off" to determine whether or not to authenticate the host.

Default: Off

[IP address]

Enter the IP address of the PC to be allowed to access the camera. Host name cannot be entered for the IP address.

Note:

- When "IP address/subnet mask" is entered, it is possible to restrict PCs in each subnet.
For example, when "192.168.0.1/24" is entered and "2. Camera control" is selected for the access level, the PCs whose IP address is between "192.168.0.0" - "192.168.0.255" can access the camera with the access level "2. Camera control".
 - When the IP address already in use is entered and the [Set] button is clicked, the respective host information will be overwritten.
-

[Access level]

Select the access level of the host from the following.

1. Administrator/ 2. Camera control/ 3. Live only

Refer to page 87 for further information about the access level.

Default: 3. Live only

Configure the settings relating to the priority stream [System]

Click the [System] tab on the "User mng." page. (☞ Pages 26 and 27: How to display/operate the setup menu)
The description below is the configuration of the priority stream that can transmit images without deteriorating the image quality and refresh interval even when multiple users access concurrently.

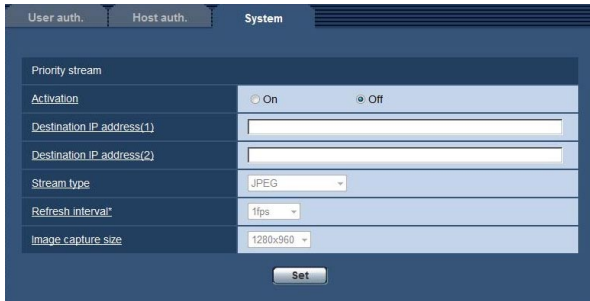

■ Priority stream

[Activation]

Select "On" or "Off" to determine whether or not to use the priority stream.

Default: Off

Note:

- When "On" is selected for "Activation" of "Priority stream", number of users who can access the camera may be limited.

[Destination IP address (1)]

Enter the first destination IP address.

[Destination IP address (2)]

Enter the second destination IP address.

[Stream type]

Select either "JPEG", "H.264/MPEG-4(1)" or "H.264/MPEG-4(2)".

JPEG: JPEG images will be transmitted.

H.264/MPEG-4(1): H.264 (1) (or MPEG-4(1)) images will be transmitted.

H.264/MPEG-4(2): H.264 (2) (or MPEG-4(2)) images will be transmitted.

Default: JPEG

Note:

- When "H.264" is selected for "Recording format", it is impossible to transmit H.264 (2) images. In this case, "H.264/MPEG-4(2)" is invalidated.

- When "Best effort" is selected for "Transmission priority" of "H.264 (MPEG-4)", bit rate will vary between the maximum and minimum rates while images are being transmitted.

[Refresh interval*]

Select the refresh interval from the following.

This setting is validated only when "JPEG" is selected for "Stream type".

SW395 **SC385**

0.1 fps / 0.2 fps / 0.33 fps / 0.5 fps / 1 fps / 2 fps / 3 fps / 5 fps / 6 fps / 10 fps / 12 fps *(PAL only) / 15 fps * / 30 fps *

SC384

0.1 fps / 0.2 fps / 0.33 fps / 0.5 fps / 1 fps / 2 fps / 3 fps / 5 fps / 6 fps * / 10 fps * / 12 fps *(PAL only) / 15 fps * / 30 fps *

Default: 1 fps

Note:

- When "On" is selected for "H.264 (MPEG-4) transmission", the transmission interval may be longer than the set value when any value with an asterisk (*) on the right is selected.

[Image capture size]

Select the image capture size from the following.

When "4:3(VGA)" is selected for "Aspect ratio"

QVGA/ VGA/ 1280x960

When "4:3(800x600)" is selected for "Aspect ratio"

SW395 **SC385**

QVGA/ 800x600/ 1280x960

When "16:9" is selected for "Aspect ratio"

320x180/ 640x360/ 1280x720

This setting is validated only when "JPEG" is selected for "Stream type".

Default: 1280x960

Configure the settings of the servers [Server]

The settings relating to the mail server, the FTP server and the NTP server can be configured on this page. The "Server" page has 3 tabs; the [Mail] tab, the [FTP] tab and the [NTP] tab.

Configure the settings relating to the mail server [Mail]

Click the [Mail] tab on the "Server" page. (☞ Pages 26 and 27: How to display/operate the setup menu)
The settings relating to the mail server used to send the alarm mail can be configured on this page.

Important:

- When a terminal that receives e-mails is not compatible with UTF-8 encode, it is impossible to receive alarm mails correctly.
-



[SMTP server address]

Enter the IP address or the host name of the SMTP server used to send e-mails.

Available number of characters: 1 - 128 characters

[SMTP port]

Enter the port number to which e-mails are sent.

Available port number: 1-65535

Unavailable port number: Refer to the help window.

Default: 25

[POP server address]

When "POP before SMTP" is selected for "Type", enter the IP address or the host name of the POP server.

Available number of characters: 1 - 128 characters

Important:

- When entering the host name for "SMTP server address" or "POP server address", it is necessary to configure the DNS settings on the [Network] tab of the "Network" page. (☞ Page 94)
-

[Authentication]

• Type

Select the authentication method to send e-mails from the following.

None: It is not necessary to clear any authentication to send e-mails.

POP before SMTP: It is necessary to first clear the POP server authentication to use the SMTP server to send e-mails.

SMTP: It is necessary to clear the SMTP server authentication to send e-mails.

Default: None

Note:

- When you don't know the authentication method to send e-mails, refer to the network administrator.
-

• User name

Enter the user name to access the server.

Available number of characters: 0 - 32 characters

• Password

Enter the password to access the server.

Available number of characters: 0 - 32 characters

[Sender's mail address]

Enter the mail address of a sender.

The entered mail address will be displayed in the "From" (sender) line of the sent mails.

Available number of characters: 3 - 128 characters

Configure the settings relating to the FTP server [FTP]

Click the [FTP] tab on the "Server" page. (☞ Pages 26 and 27: How to display/operate the setup menu)
The settings relating to the FTP server used to transmit the alarm images can be configured on this page.



[FTP server address]

Enter the IP address or the host name of the FTP server.

Available number of characters: 1 - 128 characters

Important:

- When entering the host name for "FTP server address", it is necessary to configure the DNS settings on the [Network] tab of the "Network" page. (☞ Page 94)

[User name]

Enter the user name (login name) to access the FTP server.

Available number of characters: 1 - 32 characters

[Password]

Enter the password to access the FTP server.

Available number of characters: 0 - 32 characters

[Control port]

Enter a control port number to be used for the FTP server.

Available port number: 1-65535

Unavailable port number: Refer to the help window.

Default: 21

[FTP mode]

Select "Passive" or "Active" for the FTP mode.

Normally, select "Passive". When it is impossible to connect after select "Passive", try to connect after selecting "Active".

Default: Passive

Configure the settings relating to the NTP server [NTP]

Click the [NTP] tab on the "Server" page. (☞ Pages 26 and 27: How to display/operate the setup menu)
The settings relating to the NTP server such as the NTP server address, port number, etc. can be configured on this page.

Important:

- Use an NTP server when the more accurate time & date setting is required for the system operation.
-



[Time adjustment]

Select the time adjustment method from the following. Time adjusted by the selected method will be used as the standard time of the camera.

Manual: Time set on the [Basic] tab on the "Basic" page will be used as the standard time of the camera.

Synchronization with NTP server: Time automatically adjusted by synchronizing with the NTP server will be used as the standard time of the camera.

Default: Manual

[NTP server address setting]

When "Synchronization with NTP server" is selected for "Time adjustment", select the method of how to obtain the NTP server address from the following.

Auto: Obtains the NTP server address from the DHCP server.

Manual: The NTP server address will be entered manually on "NTP server address".

Default: Manual

Important:

- When obtaining the NTP server address from the DHCP server, it is necessary to select "DHCP" or "Auto" for "Network Settings" on the [Network] tab of the "Network" page. (☞ Page 93)
-

[NTP server address]

When "Manual" is selected for "NTP server address setting", enter the IP address or the host name of the NTP server.

Available number of characters: 1 - 128 characters

Default: None (blank)

Important:

- When entering the host name for "NTP server address", it is necessary to configure the DNS settings on the [Network] tab of the "Network" page. (☞ Page 94)
-

[NTP port]

Enter a port number of the NTP server.

Available port number: 1 - 65535

Unavailable port number: Refer to the help window.

Default: 123

[Time adjustment interval]

Select an interval (1 - 24 hours: in 1 hour intervals) of synchronization with the NTP server.

Default: 1h

[Time zone]

Select a time zone corresponding to the location where the camera is in use.

Default: (GMT) Greenwich Mean Time: Dublin, Edinburgh, Lisbon, London

Configuring the network settings [Network]

The network settings and the settings relating to DDNS (Dynamic DNS) and SNMP (Simple Network management Protocol) can be configured on the "Network" page.

The "Network" page has 4 tabs; the [Network] tab, the [DDNS] tab, the [SNMP] tab and the [FTP img. trans.] tab.

Configure the network settings [Network]

Click the [Network] tab on the "Network" page. (Pages 26 and 27: How to display/operate the setup menu)

The following information is required to configure the network settings.

Contact the network administrator or your Internet service provider.

- IP address
- Subnet mask
- Default gateway (when using the gateway server/router)
- HTTP port
- Primary DNS address, Secondary DNS address (when using DNS)

The screenshot shows the 'Network' configuration page with the following settings:

- IPv4 network:** Network Settings: Static; IP address(IPv4): 192.168.0.10; Subnet mask: 255.255.255.0; Default gateway: 192.168.0.1; DNS: Auto; Primary server address: 0.0.0.0; Secondary server address: 0.0.0.0.
- IPv6 network:** Manual: Off; IP address(IPv6): ; DHCPv6: Off; Primary DNS server address: ; Secondary DNS server address: .
- Common:** HTTP port: 80; Line speed: Auto; Max RTP packet size: Unlimited(1500byte); HTTP max segment size(MSS): Unlimited(1460byte).
- UPnP:** Auto port forwarding: Off; Camera short cut: Off.
- HTTPS:** CRT key generate: Execute; Self-signed Certificate: Generate: Execute, Information: Not generated; CA Certificate: CA Certificate install: Invalid.
- FTP access to camera:** Allow/Forbid: Forbid.
- Bandwidth control (bit rate):** Unlimited.
- Easy IP Setup accommodate period:** 20min.

■ IPv4 network

[Network Settings]

Select the method of how to configure the IP address from the following.

Static: The IP address is configured by entering manually on "IP address(IPv4)".

DHCP: The IP address is configured using the DHCP function.

Auto: The IP address is configured using the DHCP function. When the DHCP server is not found, the IP address is automatically configured.

Configure the DHCP server not to assign the same IP addresses used for the other network cameras and PCs whose IP address is unique. Refer to the network administrator for further information about the settings of the server.

Default: Static

Note:

- When "Auto" is selected and the IP address cannot be obtained from the DHCP server, an IP address not used in the same network will be searched within 169.254.1.0 - 169.254.254.255.

[IP address(IPv4)]

When not using the DHCP function, enter the IP address of the camera. Do not enter an IP address already in use (for the PCs and the other network cameras).

Default: 192.168.0.10

Note:

- Multiple IP addresses are unavailable even when using the DHCP function. Refer to the network administrator for further information about the settings of the DHCP server.
-

[Subnet mask]

When not using the DHCP function, enter the subnet mask of the camera.

Default: 255.255.255.0

[Default gateway]

When not using the DHCP function, enter the default gateway of the camera.

Default: 192.168.0.1

Note:

- Multiple IP addresses for the default gateway are unavailable even when using the DHCP function. Refer to the network administrator for further information about the settings of the DHCP server.
-

[DNS]

Determine how to set the address of the DNS server by selecting "Auto" (obtain the address automatically) or "Manual" (enter the address of the DNS server). When "Manual" is selected, it is necessary to configure the settings for the DNS.

When using the DHCP function, it is possible to obtain the DNS address automatically by selecting "Auto". Refer to the network administrator for further information about the settings.

Default: Manual

[Primary server address], [Secondary server address]

When "Manual" is selected for "DNS", enter the IP address of the DNS server.

Refer to the network administrator about the IP address of the DNS server.

■ IPv6 network**[Manual]**

Select "On" or "Off" to determine whether or not to manually configure the IP address for IPv6 network (IPv6 address).

On: Enter an IPv6 address manually.

Off: Manual entry of an IPv6 address will become unavailable.

Default: Off

[IP address(IPv6)]

When "On" is selected for "Manual", manual entry of the IPv6 address is required.

Do not enter an address already in use.

Note:

- When connecting to the manually configured IPv6 address beyond the router, use an IPv6 compatible router and turn on the automatic IPv6 address assignment function. In this case, it is necessary to configure IPv6 address including prefix information provided from the IPv6 compatible router. Refer to the manuals provided with the router for further information.
-

[DHCPv6]

Select "On" or "Off" to determine whether or not to use the IPv6 DHCP function.

Configure the DHCP server not to assign the same IP addresses used for the other network cameras and PCs whose IP address is unique. Refer to the network administrator for further information about the settings of the server.

Default: Off

[Primary DNS server address], [Secondary DNS server address]

Enter the IPv6 address of the DNS server. Refer to the network administrator about the IPv6 address of the DNS server.

■ Common**[HTTP port]**

Assign the port numbers independently.

The following port numbers are unavailable since they are already in use.

Available port number: 1 - 65535

Default: 80

<Port numbers already in use>

20, 21, 23, 25, 42, 53, 67, 68, 69, 110, 123, 161, 162, 443, 554, 995, 10669, 10670, 59000 - 61000

[Line speed]

Select the line speed for data transmission from the following. It is recommended to use with the default "Auto".

Auto: Line speed will be applied automatically.

100M-Full: 100 Mbps full-duplex

100M-Half: 100 Mbps half-duplex

10M-Full: 10 Mbps full-duplex

10M-Half: 10 Mbps half-duplex

Default: Auto

[Max RTP packet size]

Select "Unlimited(1500byte)" or "Limited(1280byte)" to determine whether or not to restrict the RTP packet size when viewing images from the camera using the RTP protocol. It is recommended to use with the default "Unlimited(1500byte)".

When the RTP packet size is restricted in the network line in use, select "Limited(1280byte)". Refer to the network administrator for further information about the maximum packet size in the network line.

Default: Unlimited(1500byte)

[HTTP max segment size(MSS)]

Select "Unlimited(1460byte)" or "Limited(1024byte)" to determine whether or not to restrict the maximum segment size (MSS) when viewing images from the camera using the HTTP protocol. It is recommended to use with the default "Unlimited(1460byte)".

When the MSS is restricted in the network line in use, select "Limited(1024byte)". Refer to the network administrator for further information about the MSS in the network line.

Default: Unlimited(1460byte)

■ UPnP

This camera support UPnP (Universal Plug and Play). By using the UPnP function, it becomes possible to configure the following automatically.

- Configuration of the port forwarding function of the router(However, a router supporting UPnP is required.) This configuration is useful when accessing the camera via the Internet or from a cellular phone.
- Automatic refreshment of the shortcut to the camera that is created on the "My Network Places" folder ("Network" folder when using Windows Vista or Windows 7) of the PC even when the IP address of the camera changes

[Auto port forwarding]

Select "On" or "Off" to determine whether or not to use the port forwarding function of the router.

To use the port forwarding function, the router in use must support UPnP and the UPnP must be enabled.

Default: Off

Note:

- Due to port forwarding, the port number may sometimes be changed. When the number is changed, it is necessary to change the port numbers registered in the PC and recorders, etc.
- The UPnP function is available when the camera is connected to the IPv4 network. IPv6 is not supported.
- To check if auto port forwarding is properly configured, click the [Status] tab on the "Maintenance" page, and check that the "Enable" is displayed for "Status" of "UPnP". (☞ Page 124)
When "Enable" is not displayed, refer to "Cannot access the camera via the Internet." in the "Troubleshooting" section. (☞ Page 132)

[Camera short cut]

Select whether or not to create the shortcut to the camera on the "My Network Places" folder ("Network" folder when using Windows Vista or Windows 7) of the PC. When creating the shortcut, select "On".

To use the shortcut function to the camera, enable the UPnP function on the PC in advance.

Default: Off

Note:

- To display the shortcut to the camera on the "My Network Places" folder ("Network" folder when using Windows Vista or Windows 7) of the PC, it is necessary to add the Windows component. Refer to the following to enable the UPnP function.

For Windows XP

"Start" → "Settings" → "Control Panel" → "Add or Remove Programs" → "Add/Remove Windows Components" → select "Networking Services" → "Details" → check "Internet Gateway Device Discovery and Control Client" and "UPnP User Interface" → [OK] → [Next] → Complete

For Windows Vista

"Start" → "Control Panel" → "Network and Internet" → "Network and Sharing Center" → expand the section of "Network discovery" of "Sharing and Discovery" → select "Turn on network discovery" → click "Apply" → Complete

For Windows 7

"Start" → "Control Panel" → "Network and Internet" → "Network and Sharing Center" → select "Turn on network discovery" of "Network discovery" of "Change advanced sharing settings" → click "Save changes" → Complete

■ HTTPS

It is possible to enhance the network security by encrypting the access to cameras using the HTTPS function.

Refer to page 99 for how to configure the HTTPS settings.

[CRT key generate]

CRT key (SSL encryption key) used for the HTTPS protocol is generated.

To generate the CRT key, click the [Execute] button to display "CRT key generate" dialog box.

[Self-signed Certificate - Generate]

The camera itself generates the security certificate used for the HTTPS protocol. (Self-signed certificate)

To generate the self-signed certificate, click the [Execute] button to display the "Self-signed Certificate - Generate" dialog box.

[Self-signed Certificate - Information]

Displays the information of the self-signed certificate.

When the [Confirm] button is clicked, the registered information of the self-signed certificate will be displayed in the "Self-signed Certificate - Confirm" dialog box.

When the [Delete] button is clicked, the generated self-signed certificate will be deleted.

[CA Certificate - Generate Certificate Signing Request]

When using the security certificate issued by CA (Certificate Authority) as the security certificate used for the HTTPS protocol, the CSR (Certificate Signing Request) will be generated.

To generate the CSR, click the [Execute] button to display the "CA Certificate - Generate Certificate Signing Request" dialog window.

[CA Certificate - CA Certificate install]

Installs the server certificate (security certificate) issued by CA (Certificate Authority) and displays the information of the installed server certificate.

To install the server certificate, click the [Browse...] button to display the Open dialog box, and select the file of the server certificate issued by CA, and click the [Execute] button.

If the server certificate is already installed, the file name of the installed server certificate will be displayed.

[CA Certificate - Information]

Displays the information of the server certificate.

When the [Confirm] button is clicked, the registered information of the installed server certificate will be displayed in the "CA Certificate - Confirm" dialog box. If the server certificate is not installed, the content of the generated CSR file will be displayed.

When the [Delete] button is clicked, the installed server certificate will be deleted.

Important:

- Before deleting the valid server certificate (security certificate), confirm that there is a backup file on the PC or another media. The backup file will be required when installing the server certificate again.
-

[Connection]

Select the protocol used to connect the camera.

HTTP: Only the HTTP connection is available.

HTTPS: Only the HTTPS connection is available.

Default: HTTP

[HTTPS port]

Designate the HTTPS port number to be used.

Available port number: 1 - 65535

Default: 443

Note:

- This camera will restart after the connection setting is changed.
- Notation when using the self-signed certificate
If the camera is accessed using the HTTPS protocol for the first time, the warning window will be displayed. In this case, follow the instructions of the wizard to install the self-signed certificate.
(☞ Page 106)
- Notation when using the server certificate
In advance, install the root certificate and intermediate certificate on the browser in use. Follow the instructions of CA for how to obtain and install these certificates.
- When the camera is accessed using the HTTPS protocol, the refresh interval and frame rate of images may be lower.
- When the camera is accessed using the HTTPS protocol, it may take time to display images.
- When the camera is accessed using the HTTPS protocol, the images may be distorted or audio may be interrupted.

-
- The maximum number of concurrent access user varies depending on the maximum image size and transmission format.
-

[FTP access to camera]

Select "Allow" or "Forbid" to determine whether to allow or forbid the FTP access to camera.

Default: Forbid

[Bandwidth control(bit rate)]

Select the total bit rate for data transmission from the following.

Unlimited/ 64kbps/ 128kbps/ 256kbps/ 384kbps/
512kbps/ 768kbps/ 1024kbps/ 2048kbps/ 4096kbps/
8192kbps

Default: Unlimited

Note:

- When selecting "64kbps", select "Off" for "Audio transmission/reception" on the [Audio] tab.
( Page 72)
 - Select "128kbps" or a faster rate to carry out the live transmission of JPEG images and the FTP periodic image transmission simultaneously.
 - When "Bandwidth control(bit rate)" is set low, taking a picture using the snap shot button may not function depending on the use environment.
In this case, select "QVGA" for "Image capture size" of "JPEG" on the [JPEG/H.264] (or [JPEG/MPEG-4]) tab or set "Image quality setting" of "JPEG" lower.
-

[Easy IP Setup accommodate period]

Select "20min" or "Unlimited" to determine how long the network setting operation using the Panasonic IP setting software can be allowed.

20min: The camera information display and the network setting operation using the Panasonic IP setting software are allowed for 20 minutes since the camera starts up.

Unlimited: The camera information display and the network setting operation using the Panasonic IP setting software are allowed without time limitation.

Default: 20min

Note:

- Refer to the network administrator for the addresses of each server.
- The port forwarding function changes a global IP address to a private IP address, and "Static IP masquerade" and "Network Address Translation (NAT)" have this function. This function is to be set in a router.
- To access the camera via the Internet by connecting the camera to a router, it is necessary to assign a respective HTTP port number for each camera and address translation by using the port forwarding function of the router. For further information, refer to the operating instructions of the router in use.

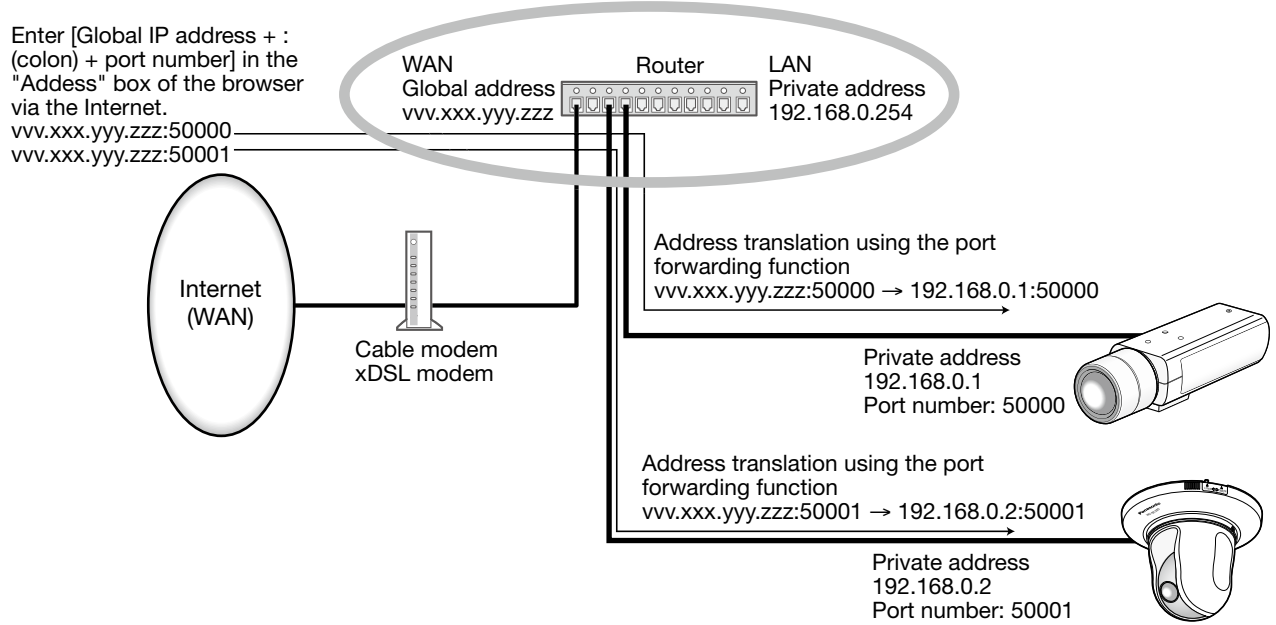

Configure the HTTPS settings

Click the [Network] tab on the "Network" page. (☞ Pages 26 and 27: How to display/operate the setup menu)
 The settings relating to the HTTPS protocol that can enhance the network security by encrypting the access to cameras on this page.

The HTTPS settings will be configured in the following procedure.

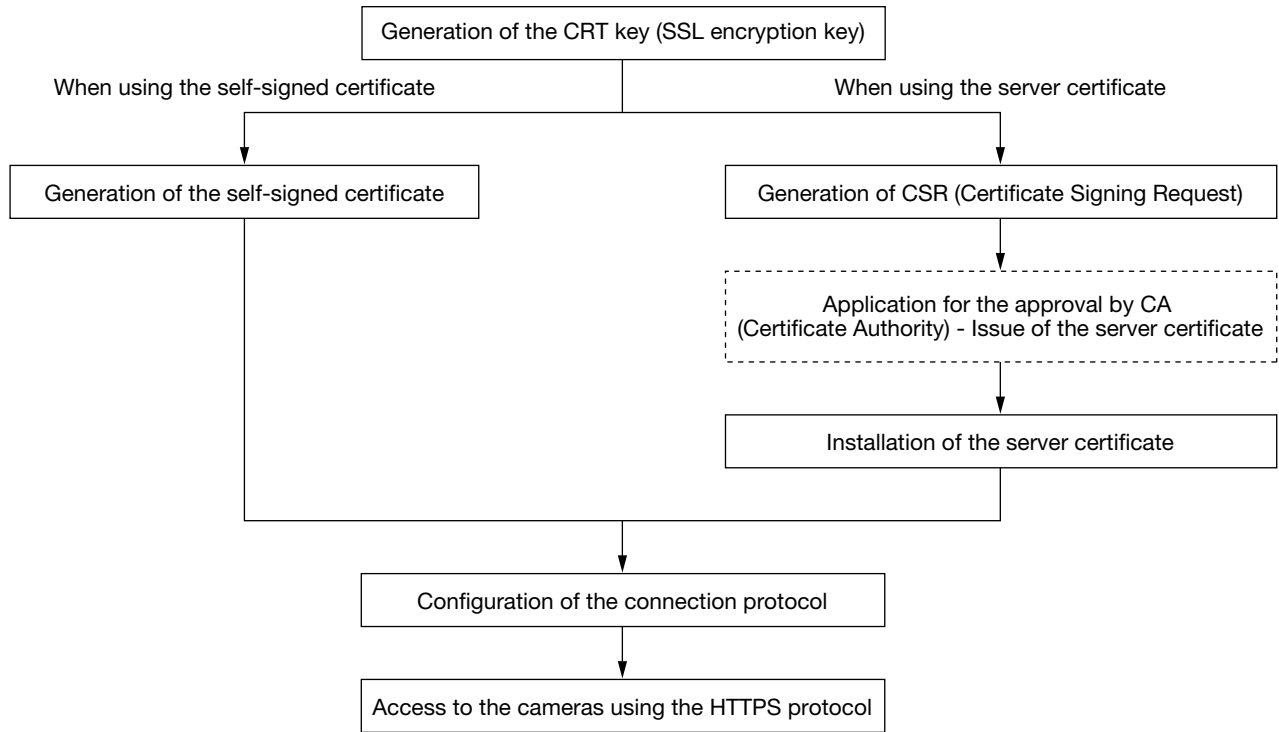

HTTPS	
CRT_key generate	<input type="button" value="Execute"/>
Self-signed Certificate	Generate <input type="button" value="Execute"/>
	Information Not generated <input type="button" value="Confirm"/> <input type="button" value="Delete"/>
CA Certificate	Generate Certificate Signing Request <input type="button" value="Execute"/>
	CA Certificate install <input type="text"/> <input type="button" value="Browse"/> <input type="button" value="Execute"/>
	Information Invalid <input type="button" value="Confirm"/> <input type="button" value="Delete"/>
Connection	HTTP <input type="button" value="Set"/>
HTTPS port	443 (1-65535)

- └─ Generation of the CRT key (SSL encryption key) (☞ page 100)
- └─ Generation of the self-signed certificate (☞ page 101)
- └─ Generation of CSR (Certificate Signing Request) (☞ page 103)
- └─ Installation of the server certificate (☞ page 104)
- └─ Configuration of the connection protocol (☞ page 105)

Note:

- To use the server certificate, you need to apply for the approval and the issue of server certificate by CA.
- Either of the self-signed certificate or the server certificate is available. If both of them are installed, the server certificate will be used prior to the self-signed certificate.

Generation of the CRT key (SSL encryption key)

Important:

- When the self-signed certificate or server certificate is valid, it is impossible to generate the CRT key.
- When the server certification is used, the available key size varies depending on the Caches the available key size in advance.
- To generate the CRT key, it may take around 1 minute when the key size is 1024 bit and around 2 minutes when the key size is 2048 bit. Do not operate the web browser until the generation of CRT key is complete. While the CRT key is being generated, the refresh interval and line speed may be lower.

Current CRT key	
CRT key	
RSA key size	
Last modified	Not generated
History	

CRT key generate

RSA key size 1024bit 2048bit [Execute](#)

*Generating a CRT key takes about 2 minutes.

[Close](#)

Step 1

Click the [Execute] button of "CRT key generate".
→ The "CRT key generate" dialog box will be displayed.

Step 2

Select "1024 bit" or "2048 bit" for the length of the CRT to generate for "CRT key generate" - "RSA key size".

Note:

- To use the server certificate, follow the requests from the CA about the RSA key size.

Step 3

Click the [Execute] button.
→ The generation of CRT key will be started.
When the generation is finished, the key size and generation time & date of the generated key will be displayed on "Current CRT key".

Note:

- To change (or update) the generated CRT key, perform Step 1 to 3. The CRT key, self-signed certificate and server certification are valid in a set. When the CRT key is changed, it is necessary to re-generate the self-signed certificate or re-apply for the server certificate.
- When the CRT key is updated, the log of the previous CRT key is saved. When the [History] button of "Current CRT key" on the "CRT key generate" dialog box is clicked, the "Previous CRT key" dialog box will be displayed, and it is possible to check the key size and generation time & date of the previous key.

Previous CRT key	
History	
RSA key size	2048bit
Last modified	2010/01/01 12:00:00
Apply	
Close	

When the [Apply] button is clicked on the "Previous CRT key" dialog box, it is possible to replace the current CRT key with the previous one.

Generation of the self-signed certificate (security certificate)

Important:

- If the CRT key is not generated, it is impossible to generate the self-signed certificate.

Step 1

Click the [Execute] button of "Self-signed Certificate - Generate".

→ The "Self-signed Certificate - Generate" dialog box will be displayed.

Step 2

Enter the information of the certificate to be generated.

Item	Description	Available number of characters
[Common Name]	Enter the camera address or host name.	64 characters
[Country]	Enter the country name. (Omission is OK.)	2 characters (Country code)
[State]	Enter the state name. (Omission is OK.)	128 characters
[Locality]	Enter the locality name. (Omission is OK.)	128 characters
[Organization]	Enter the organization name. (Omission is OK.)	64 characters
[Organizational Unit]	Enter the unit name of the organization. (Omission is OK.)	64 characters
[CRT key]	Displays the key size and generation time & date of the current key.	

Note:

- When the camera is connected to the Internet, enter the address name or host name to access via the Internet for "Common Name". In this case, the security alert window will be displayed each time the camera is locally accessed, even if the security certificate is installed.
- When entering the IPv6 address for "Common Name", put the address in brackets [].
Example: [2001:db8::10]
- The available characters for [Common Name], [State], [Locality], [Organization], [Organizational Unit] are 0-9, A-Z, a-z and the following marks.
- . _ , + / ()

Step 3

Click the [OK] button after entering the items.

→ The self-signed certificate will be generated.

Note:

- The information of the generated self-signed certificate will be displayed on "Self-signed Certificate" - "Information".
Depending on the status of the self-signed certificate, the following are displayed.

Indication	Description
Not generated	The self-signed certificate are not generated.
Invalid (Reason: CA Certificate installed)	The self-signed certificate has already been generated, and the server certificate has been installed. • In this case, the server certificate is validated.
Common name of the self-signed certificate	The self-signed certificate has already been generated and validated.

- When the [Confirm] button is clicked, the registered information of the self-signed certificate (security certificate) will be displayed in the "Self-signed Certificate - Confirm" dialog box.

Self-signed Certificate - Confirm		
Common Name	MOCAM	
Country		
State		
Locality		
Organization		
Organizational Unit		
CRT key	RSA key size	2048bit
	Last modified	2010/01/01 12:00:00

- When the [Delete] button is clicked, the generated self-signed certificate (security certificate) will be deleted.
 - When "HTTPS" is selected for "Connection", it is impossible to delete the self-signed certificate.
-

Generation of CSR (Certificate Signing Request)

Important:

- If the CRT key is not generated, it is impossible to generate the CSR.
- Before generating the CSR file, configure the following settings on "Internet Options" of the web browser in advance. (Click "Internet Options..." under "Tools" of the menu bar of Internet Explorer®, and then click the [Security] tab.)
 - Register the camera for "Trusted sites".
 - Click the [Custom Level...] button to open the "Security Setting" window, and check the [Enable] radio button of "File Download" under "Downloads".
 - Click the [Custom Level...] button to open the "Security Setting" window, and check the [Enable] radio button of "Automatic prompting for file downloads" under "Downloads".

Step 1

Click the [Execute] button of "CA Certificate - Generate Certificate Signing Request".

→ The "CA Certificate - Generate Certificate Signing Request" dialog box will be displayed.

Step 2

Enter the information of the certificate to be generated.

Item	Description	Available number of characters
[Common Name]	Enter the camera address or host name.	64 characters
[Country]	Enter the country name.	2 characters (Country code)
[State]	Enter the state name.	128 characters
[Locality]	Enter the locality name.	128 characters
[Organization]	Enter the organization name.	64 characters
[Organizational Unit]	Enter the unit name of the organization.	64 characters
[CRT key]	Displays the key size and generation time & date of the current key.	

Note:

- To use the server certificate, follow the requests from the CA about the information to be entered.

Step 3

Click the [OK] button after entering the items.

→ The "Save As" dialog box will be displayed.

Step 4

Enter a file name for the CSR in the "Save As" dialog box to save on the PC.

→ The saved CSR file will be applied to the CA.

Important:

- The server certificate will be issued for the set of the generated CSR and CRT key. If the CRT key is re-generated or updated after applying to the CA, the issued server certificate will be invalidated.

Note:

- This camera generates the CSR file in the PEM format.

Installation of the server certificate

Important:

- If the CSR file is not generated, it is impossible to install the server certificate (security certificate). For the installation, the server certificate issued by CA is required.

Step 1

Click the [Browse...] button of "CA Certificate - CA Certificate install".

→ The Open dialog box will be displayed.

Step 2

Select the server certification file and click the [Open] button. Then, click the [Execute] button.

→ The server certification will be installed.

Note:

- The host name registered in the installed server certificate will be displayed on "CA Certificate - Information". Depending on the status of the server certificate, the following are displayed.

Indication	Description
Invalid	The server certification is not installed.
Common name of the server certificate	The server certificate has already been installed and validated.
Expired	The server certification has already expired.

- When the [Confirm] button is clicked, the registered information of the installed server certificate will be displayed in the "CA Certificate - Confirm" dialog box. (Only "Organizational Unit" will be displayed with an asterisk (*).)

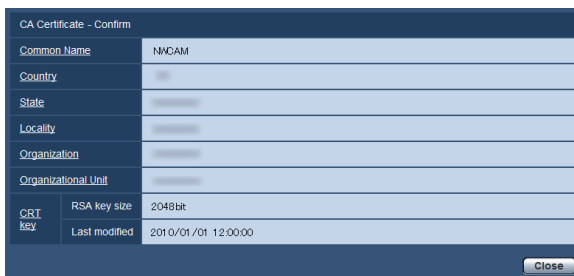

- When the [Delete] button is clicked, the installed server certificate will be deleted.
- When "HTTPS" is selected for "Connection", it is impossible to delete the server certificate.
- To change (or update) the server certificate, perform Step 1 and 2.

Important:

- Before deleting the valid server certificate (security certificate), confirm that there is a backup file on the PC or another media. The backup file will be required when installing the server certificate again.
- When the server certificate has expired, the HTTPS function will become unavailable. When the camera is restarted, the connection protocol will be changed to HTTP. Update the server certificate before it expires.
- The expiration date of the server certificate can be checked by double-clicking the server certification file issued by CA.

Configuration of the connection protocol

Step 1

Select "HTTP" or "HTTPS" for "Connection" to determine the protocol used to access the camera.

HTTP: Only the HTTP connection is available.

HTTPS: Only the HTTPS connection is available.

Step 2

Designate the HTTPS port number to be used for "HTTPS port".

Available port number: 1 - 65535

Default: 443

The following port numbers are unavailable since they are already in use.

<Port numbers already in use>

20, 21, 23, 25, 42, 53, 67, 68, 69, 80, 110, 123, 161, 162, 554, 995, 10669, 10670, 59000 - 61000

Step 3

Click the [Set] button.

→ The camera will restart, and it will become possible to access to the cameras using the HTTPS protocol.

(☞ Page 6: Monitor images on a PC, page 14: Monitor images on a cellular phone)

Note:

- This camera will restart after the connection setting is changed.
 - Notation when using the self-signed certificate: If the camera is accessed using the HTTPS protocol for the first time, the warning window will be displayed. In this case, follow the instructions of the wizard to install the self-signed certificate. (☞ Page 106)
 - Notation when using the server certificate: In advance, install the root certificate and intermediate certificate on the browser in use. Follow the instructions of CA for how to obtain and install these certificates.
 - When the camera is accessed using the HTTPS protocol, the refresh interval and frame rate of images may be lower.
 - When the camera is accessed using the HTTPS protocol, it may take time to display images.
 - When the camera is accessed using the HTTPS protocol, the images may be distorted or audio may be interrupted.
 - The maximum number of concurrent access user varies depending on the maximum image size and transmission format.
-

Access the camera using the HTTPS protocol

Step 1

Start up the web browser.

Step 2

Enter the IP address of the camera in the address box of the browser.

Example of entry: https://192.168.0.10/

Important:

- When the HTTPS port number is changed from "443", enter "https://IP address of the camera + : (colon) + port number" in the address box of the browser.
(Example: https://192.168.0.11:61443)
 - When the PC is in a local network, configure the proxy server setting of the web browser (under "Internet Options..." under "Tools" of the menu bar) to bypass the proxy server for the local address.
-

Step 3

Press the [Enter] key on the keyboard.

- The "Live" page will be displayed.
When the security alert window is displayed, install the security certificate. (☞ Pages 107 - 110)
When "On" is selected for "User auth.", the authentication window will be displayed before displaying live images for the user name and password entries.

Important:

- When the camera is accessed using the HTTPS protocol, the refresh interval and frame rate of images may be lower.
-

Install the self-signed certificate (security certificate)

When using the security certificate as the security certificate used for the HTTPS protocol and when the security certificate of the camera to access is not installed on the PC, the security alert window will be displayed each time the camera is accessed using the HTTPS protocol. To have the security alert window not displayed, it is necessary to install the security certificate in the following procedure. If the certificate is not installed, the alert window will be displayed each time the camera is accessed.

Note:

- The security certificate is installed on the PC with the information registered for "Common Name". Therefore, the information registered for "Common Name" must be same as the address or host name for the camera access. If the certificate is not the same, the security alert window will be displayed each time the camera is accessed.
 - When the address or host name of the camera is changed, the security alert window will be displayed each time the camera is accessed even if the security certificate is installed. Install the security certificate again.
 - When the camera access is open to the Internet, enter the address name or host name to access via the Internet for "Common Name". In this case, the security alert window will be displayed each time the camera is locally accessed, even if the security certificate is installed.
 - When the security certificate is properly installed, a key icon is displayed in the address box of the web browser that has accessed the camera.(When using Internet Explorer 7, Internet Explorer 8)
-

OS: Windows 7, Windows Vista, Windows XP

Web browser: When using Internet Explorer 7, Internet Explorer 8

When using Internet Explorer 7 or Windows XP Internet Explorer 8 with Windows XP, note that some of the displayed windows may differ from the following descriptions.

Step 1

Access the camera using the HTTPS protocol.

Step 2

When the security alert window is displayed, click "Continue to this website (not recommended)."

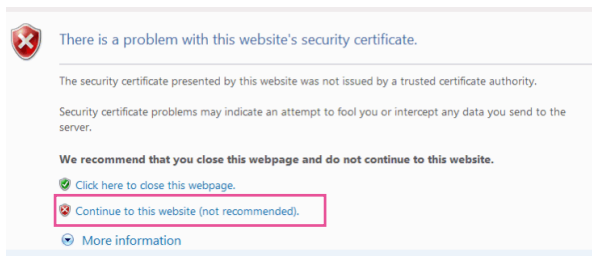

→ The "Live" page will be displayed. If the authentication window is displayed, enter the user name and password.

Note:

- If this window is displayed when accessing a device other than the camera or a website, a security problem may have occurred. In this case, check the system status.

Step 3

Click "Certificate Error" over the URL, and click "View Certificates".

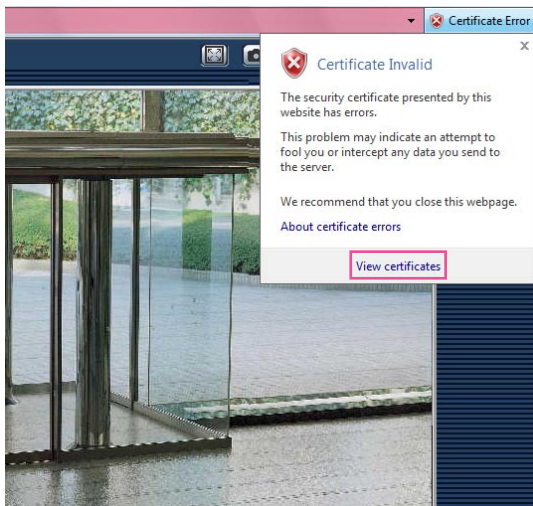

Step 4

Click "Install Certificate...".

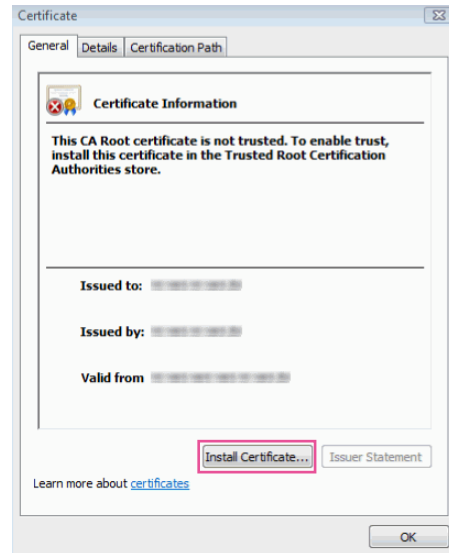

Note:

- If "Install Certificate..." is not displayed, close Internet Explorer once, and select "Run as Administrator" to launch Internet Explorer again. Click "Start" → "Programs" → right click "Internet Explorer" → click "Run as Administrator".

Step 5

Click "Next" displayed on "Certificate Import Wizard".



Step 6

Select "Place all certificates in the following store", and click "Browse...".

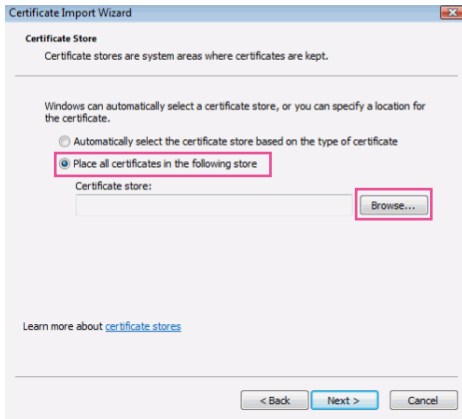

Step 9

Click "Finish".

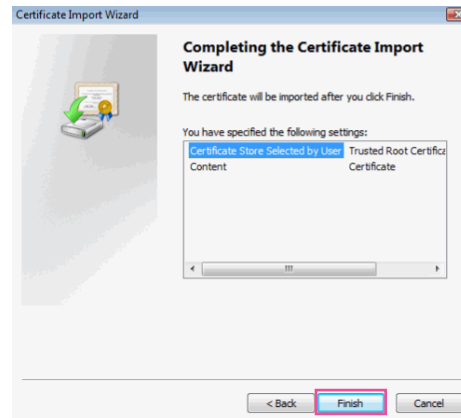

Step 7

Select "Trusted Root Certificate Authorities", and click "OK".

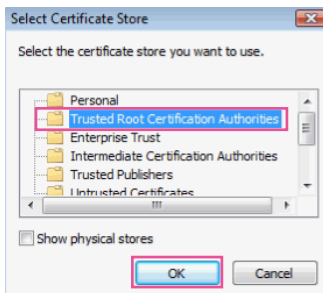

Step 10

Click "Yes".

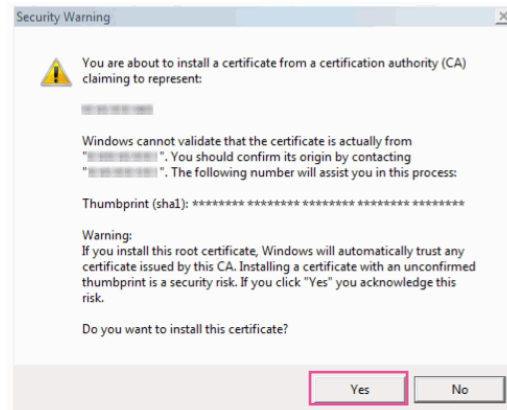

Step 8

Click "Next".

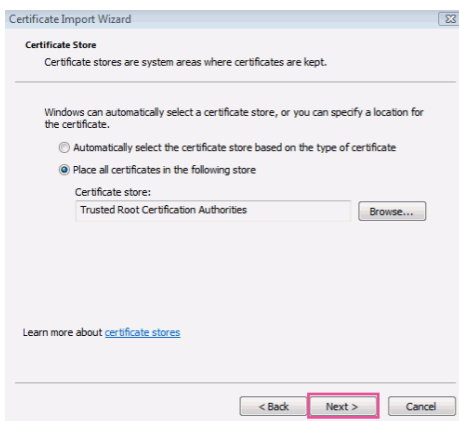

→ When the import is successfully completed, the screen "The import was successful." will be displayed.

Step 11

Click "OK".

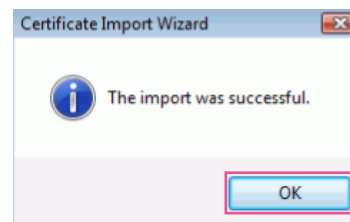

→ When the browser is restarted after the certificate is imported, "Certificate Error" will not be displayed.

OS: Windows XP

Web browser: When using Internet Explorer 6

Step 1

Access the camera using the HTTPS protocol.

Step 2

Click "View Certificate".



Note:

- If this window is displayed when accessing a device other than the camera or a website, a security problem may have occurred. In this case, check the system status.

Step 3

Click "Install Certificate...".

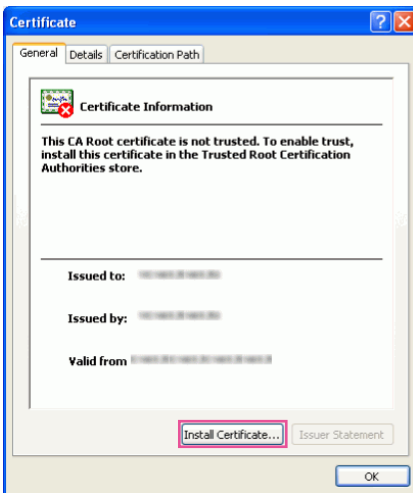

Step 4

Click "Next >" according to the procedures displayed on the displayed on "Certificate Import Wizard".

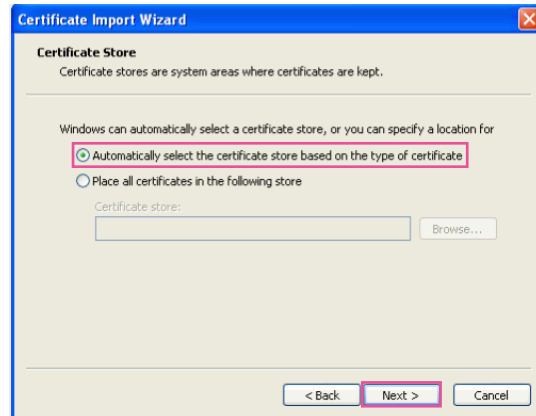
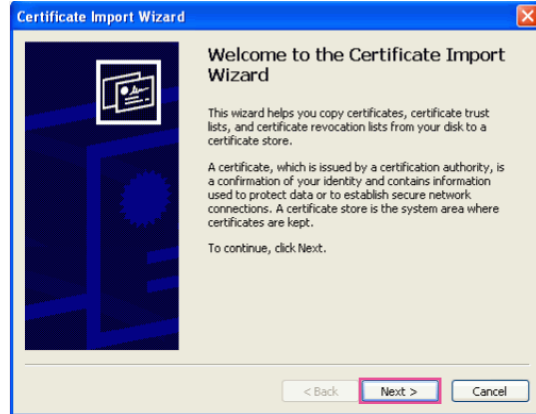

Step 5

Click "Finish".

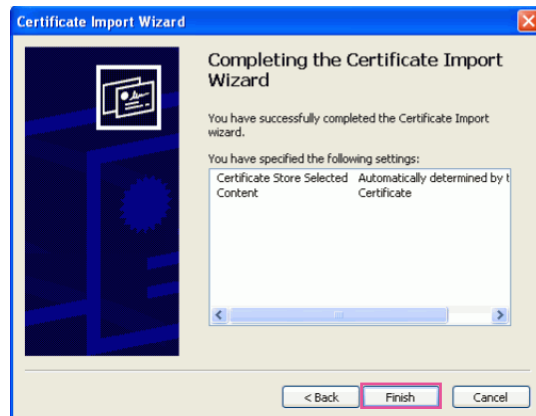

Step 6

When the security alert window is displayed, click "Yes".

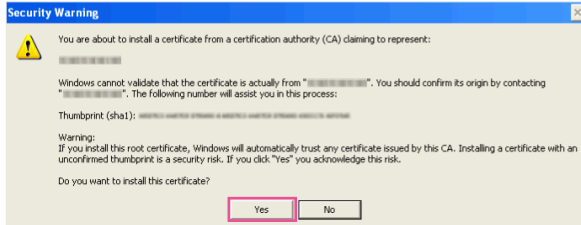

→ When the import is successfully completed, the screen "The import was successful." will be displayed.

Step 7

Click "OK".



→ When the browser is restarted after the certificate is imported, "Certificate Error" will not be displayed.

Configure the settings relating to DDNS [DDNS]

Click the [DDNS] tab on the "Network" page. (☞ Pages 26 and 27: How to display/operate the setup menu)

To access this camera via the Internet, it is necessary to configure the settings for the DDNS function.

When activating the DDNS function using the camera, either of the following DDNS services is available.

- Viewnetcam
- Dynamic DNS Update (RFC2136 compliant)

Important:

- Before using the DDNS service, it is necessary to perform the port forwarding setting for the router.
- About Dynamic DNS Update (RFC2136 compliant)
Operation using DDNS services other than the "Viewnetcam" service is not guaranteed. We are not responsible for any troubles or accidents on the circumstances where the camera is used arising out of such services. Refer to the DDNS service providers for the selection and configuration of the DDNS services other than the "Viewnetcam" service.

Note:

- "Viewnetcam" is a Dynamic DNS service designed for use with Panasonic Network Cameras. Refer to the "Viewnetcam" website (<http://www.viewnetcam.com/>) for further information about the service.
-

About DDNS services (IPv4/IPv6)

By using a DDNS service, it becomes possible to view camera images via the Internet

The DDNS service associates dynamic global addresses and domain names.

It is possible to configure the settings for the "Viewnetcam"* or Dynamic DNS Update (RFC2136 compliant).

In most of the DNS services offered by providers, global addresses are not static but dynamic. Therefore, access to the camera via an old global address may be invalidated after a certain period of time. Either of the following services is required when accessing a camera whose global address is not static via the Internet.

- DDNS service (such as "Viewnetcam")
It is possible to access via a registered and static domain name (example: *****.viewnetcam.com) even after the global address is changed. Enrollment in a domain name service is required even when using the IPv6 connection.
Refer to the "Viewnetcam" website (<http://www.viewnetcam.com/>) for further information about the service.
- Static IP address service (such as a service offered by a contracted provider)
In this service, global addresses are static (not changed).

Configuration of the DDNS service (Example of the "Viewnetcam" service)

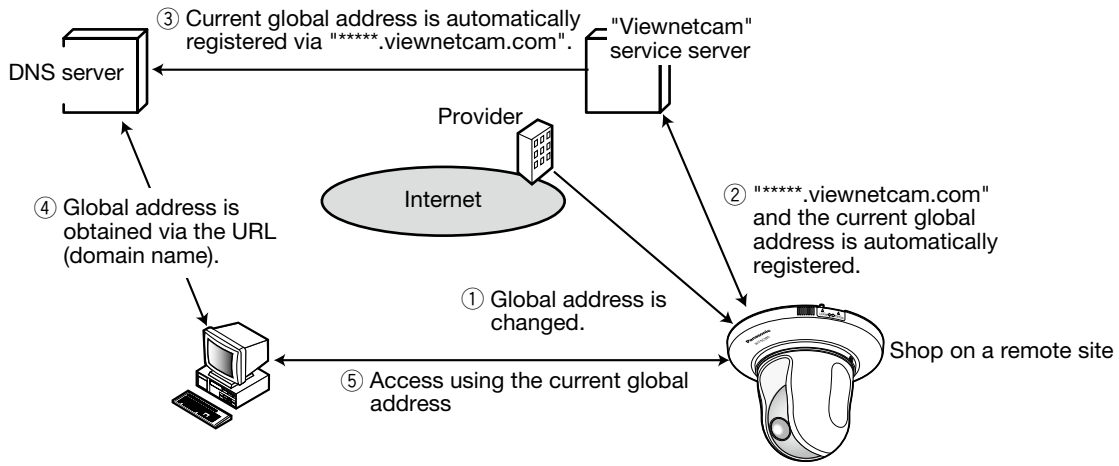

1. The contracted provider allocates a global address to the router (or the camera). The global address is not static but dynamic.
2. If you are enrolled in "Viewnetcam", the unique "domain name" (example: *****.viewnetcam.com) will be allocated. The "Viewnetcam" service server automatically manages the domain name of camera and the global address of router (or camera) when a camera automatically notifies the service server of the global address.
3. The "Viewnetcam" service server registers the global address and the domain name of router (or camera) in the DNS server.
4. By entering the URL (including the domain name) on the web browser when accessing the camera via the Internet, the DNS server identifies the registered global address of router (or camera).
5. The identified global address is used for accessing the router (or camera) to monitor images.

Note:

- Refer to the contracted provider whether the current IP address is static or not.
- Depending on the provider, local addresses may be allocated. In this case, the DDNS service is unavailable. Refer to the contract provider for further information.

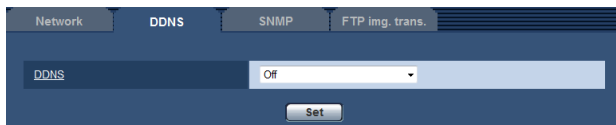

[DDNS]

Select the DDNS service to determine whether or not to use DDNS.

Off: Does not use the DDNS function.

Viewnetcam: Uses the "Viewnetcam" service.

Dynamic DNS Update: Uses Dynamic DNS Update (RFC2136 compliant) without the DHCP cooperation.

Dynamic DNS Update(DHCP): Uses Dynamic DNS Update (RFC2136 compliant) with the DHCP cooperation.

Default: Off

Note:

- When using Dynamic DNS Update (RFC2136 compliant), Refer to the network administrator for whether or not to cooperate with the DHCP.

When using the "Viewnetcam" service

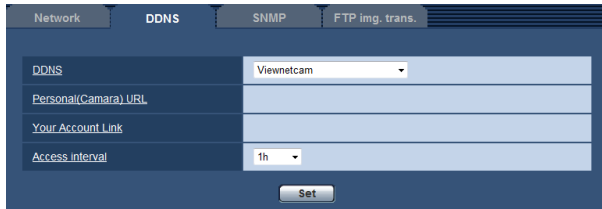

The screenshot shows a configuration page with tabs for Network, DDNS, SNMP, and FTP img. trans. The DDNS tab is active. It contains a dropdown menu for DDNS set to 'Viewnetcam', a text input field for 'Personal(Camera) URL', a text input field for 'Your Account Link', and a dropdown menu for 'Access interval' set to '1h'. A 'Set' button is located at the bottom right of the form.

[Personal(Camera) URL]

The URL of the camera registered for "Viewnetcam".
When performing the initial settings, the temporary URL will be displayed by clicking the [Set] button.

[Your Account Link]

When the displayed URL is clicked, the registration window for the "Viewnetcam" service will be displayed in a newly opened window.
Register the information in the registration window to enroll in the "Viewnetcam" service.

[Access interval]

Select the interval to access the "Viewnetcam" service server to check the IP address and the host name from the following.

10min/ 20min/ 30min/ 40min/ 50min/ 1h

Default: 1h

Procedure to register information for the "Viewnetcam" service

Step 1

Click the displayed URL "https://*****" of "Your Account Link".

→ The registration window for "Viewnetcam" will be displayed in a newly opened window.

Step 2

Register the information for "Viewnetcam" by following the instructions of the wizard.

→ When the registration window is not displayed, check that the PC is being connected to the Internet, and click the reload button of the browser. When the message "The new camera is successfully registered to Viewnetcam.com" is displayed, close the registration window.

The URL selected at the time of registration can be used for camera access. However, this URL is unavailable when accessing the camera from the PC connected to the same network (LAN).

Note:

- When the registration for the "Viewnetcam" service is completed, the URL of the camera registered for "Personal(Camera) URL". It may take up to around 30 minutes until the URL of the registered camera is validated.
- To cancel the enrollment in the "Viewnetcam" service, access the "Viewnetcam" website (<http://www.viewnetcam.com/>) later.
- It is possible to check the information registered for the "Viewnetcam" service by accessing the URL displayed beside "Your Account Link". When the URL is not displayed, check that the PC is being connected to the Internet, and click the [Set] button.
- If access often fails due to the change in the global address of router, set a smaller value for "Access interval".

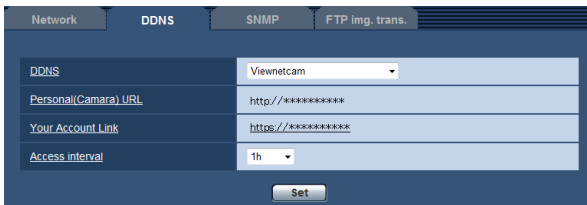

The screenshot shows a configuration interface with tabs for Network, DDNS, SNMP, and FTP img. trans. The DDNS tab is active. It contains the following fields:

DDNS	Viewnetcam
Personal(Camera) URL	http://*****
Your Account Link	https://*****
Access interval	1h

A "Set" button is located at the bottom of the form.

Checking the information registered for the "Viewnetcam" service

It is possible to check if the camera has been registered for the "Viewnetcam" service. (Page 124)

When using "Dynamic DNS Update"

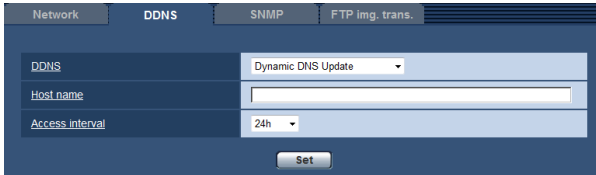

The screenshot shows a configuration page with tabs for Network, DDNS, SNMP, and FTP img. trans. The DDNS tab is active. A dropdown menu is set to 'Dynamic DNS Update'. Below it, there is a text input field for 'Host name' and a dropdown menu for 'Access interval' set to '24h'. A 'Set' button is at the bottom.

[Access interval]

Select the interval to access the Dynamic DNS Update service server to check the IP address and the host name from the following.

10min/ 20min/ 30min/ 40min/ 50min/ 1h/ 6h/ 24h

Default: 24h

[Host name]

Enter the host name to be used for the Dynamic DNS Update service.

Available number of characters: 3 - 250

Enter in the form of "(host name). (domain name)".

Default: None (blank)

Note:

- Refer to the network administrator for further information about the available host names.
-

When using "Dynamic DNS Update(DHCP)"

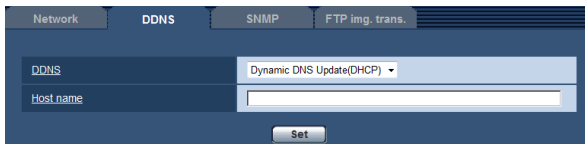

The screenshot shows a configuration page with tabs for Network, DDNS, SNMP, and FTP img. trans. The DDNS tab is active. A dropdown menu is set to 'Dynamic DNS Update(DHCP)'. Below it, there is a text input field for 'Host name'. A 'Set' button is at the bottom.

[Host name]

Enter the host name to be used for the Dynamic DNS Update service.

Available number of characters: 3 - 250

Enter in the form of "(host name). (domain name)".

Default: None (blank)

Note:

- Refer to the network administrator for further information about the available host names.
-

Configure the settings relating to SNMP [SNMP]

Click the [SNMP] tab on the "Network" page. (☞ Pages 26 and 27: How to display/operate the setup menu)
The settings relating to SNMP can be configured on this page. It is possible to check the status of the camera by connecting to the SNMP manager. When using the SNMP function, contact the network administrator.

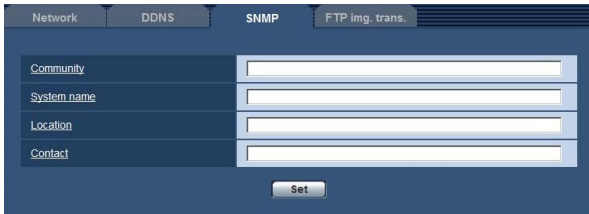

[Community]

Enter the community name to be monitored.

Available number of characters: 0 - 32 characters

Default: None (blank)

Important:

- When using the SNMP function, it is necessary to enter the community name. When no community name is entered, the SNMP function will not work.

[System name]

Enter a system name to be used to manage the camera with the SNMP function.

Available number of characters: 0 - 32 characters

Default: None (blank)

[Location]

Enter the name of the location where the camera is installed.

Available number of characters: 0 - 32 characters

Default: None (blank)

[Contact]

Enter the mail address or the phone number of the SNMP manager.

Available number of characters: 0 - 255 characters

Default: None (blank)

Configure the settings relating to the FTP periodic image transmission [FTP img. trans.]

Click the [FTP img. trans.] tab on the "Network" page. (☞ Pages 26 and 27: How to display/operate the setup menu)

The settings relating to the periodic transmission of images to an FTP server can be configured on this page. To transmit images to an FTP server periodically, it is necessary to configure the settings of the FTP server in advance (☞ page 91). Refer to page 118 for descriptions of how to configure schedules of image transmission.

Important:

- Depending on the network line speed or the network traffic, images may not be transmitted at the exact designated interval or period.
- Select "FTP error" for "Save trigger" on the [SD memory card] tab when using the FTP periodic transmission function.
- When "On" is selected for both of the alarm image transmission function and the FTP periodic image transmission function, the alarm image transmission function will be given priority over the FTP periodic image transmission function. For this reason, images may not be transmitted at the exact designated interval or period if alarms occur frequently.

Note:

- When "FTP error" is selected for "Save trigger" on the [SD memory card] tab, images that have failed to transmit using the FTP periodic image transmission can be saved automatically on the SD memory card.

(☞ Page 19)



■ FTP periodic image transmission

[FTP >>]

When "FTP >>" is clicked, the [FTP] tab of the "Server" page will be displayed. (☞ Page 91)

[FTP periodic image transmission]

Select "On" or "Off" to determine whether or not to transmit images using the FTP periodic image transmission function.

When "On" is selected, it is necessary to configure the settings of the FTP server. (☞ Page 91)

Default: Off

[Directory name]

Enter the directory name where the images are to be saved.

For example, enter "/img" to designate the directory "img" under the root directory of the FTP server.

Available number of characters: 1 - 256 characters

Default: None (blank)

[File name]

Enter the file name (name of the image file to be transmitted) and select the naming option from the following.

Name w/time&date: File name will be ["Entered file name" + "Time and date (year/ month/ day/ hour/ minute/ second)" + "Serial number (starting from 00)"].

Name w/o time&date: File name will be the characters entered for "File name" only. When "Name w/o time&date" is selected, the file will be overwritten each time a file is newly transmitted.

Available number of characters: 1 - 32 characters

Default: None (blank)

Note:

- When "Name w/time&date" is selected, the file name will be ["Entered file name" + "Time and date (year/ month/ day/ hour/ minute/ second)" + "Serial number (starting from 00)"] + "s" during summer time.
-

[Transmission interval]

Select the interval for the FTP periodic image transmission from the following.

1s/ 2s/ 3s/ 4s/ 5s/ 6s/ 10s/ 15s/ 20s/ 30s/ 1min/ 2min/ 3min/ 4min/ 5min/ 6min/ 10min/ 15min/ 20min/ 30min/ 1h/ 1.5 h/ 2h/ 3h/ 4h/ 6h/ 12h/ 24 h

Default: 1s

[Image capture size]

Select the capture size of images to be transmitted from the following.

When "4:3(VGA)" is selected for "Aspect ratio"

QVGA/ VGA/ 1280x960

When "4:3(800x600)" is selected for "Aspect ratio"

SW395 SC385

QVGA/ 800x600/ 1280x960

When "16:9" is selected for "Aspect ratio"

320x180/ 640x360/ 1280x720

Default: VGA

Configure the schedule settings of the FTP periodic image transmission [FTP img. trans.]

Click the [FTP img. trans.] tab on the "Network" page. (☞ Pages 26 and 27: How to display/operate the setup menu)

The schedule settings of the FTP periodic image transmission can be configured in this section. Refer to page 117 for further information about the settings relating to the FTP periodic image transmission.

How to set the schedules

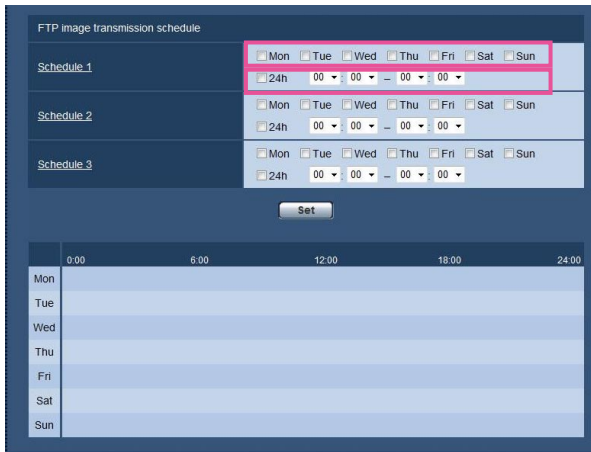

Step 1

Check the check box of the desired day of the week of "FTP image transmission schedule".

→ The selected day of the week will be validated for the schedule.

Step 2

To designate time, click [▼] and select the desired "hour" and "minute".

When not designating time, check the checkbox of "24h".

Step 3

Click the [Set] button after completing the settings.

→ The result will be displayed at the bottom of the window.

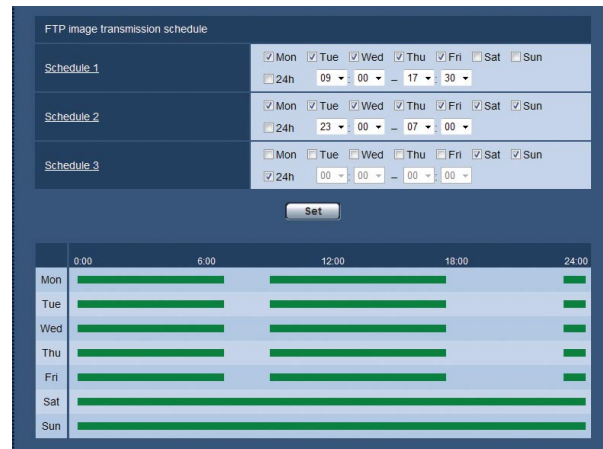

How to delete the set schedule



Step 1

Uncheck the check box of the set day of the week.

Step 2

Click the [Set] button after completing the settings.
→ The schedule of the selected day of the week is deleted.



Configure the settings relating to the schedules [Schedule]

On the "Schedule" page, it is possible to configure the settings relating to schedules as follows.

- Alarm permission (Alarm input will be received only in the specified schedule.)
- VMD permission (Video motion detection will be active only in the specified schedule.)
- Access permission (Access to the camera will be allowed only in the specified schedule.)
- H.264 recording (SD recording will be performed only in the specified schedule.)
- Position refresh (Camera position will be refreshed only in the specified schedule.)

The "Schedule" page has only the [Schedule] tab.

Up to 5 schedules can be set.



Step 1

Select an action to be assigned to the schedule from "Schedule mode".

"Off" is selected at the default.

Off: No action will be taken for the respective schedule.

Alarm permission: Alarm input (terminal alarm) will be received during the period of the schedule.

VMD permission: The video motion detection (VMD) function will be active during the period of the schedule.

Access permission: Users whose access level is set to 2 and 3 on the "User auth." tab (page 87) can access the camera only in the period of schedule.

H.264 recording: The SD recording will be performed at the designated time in the schedule.

Position refresh: The camera position will be refreshed at the designated time in the schedule.

1-64: The camera will move to the designated preset position at the designated time in the schedule.

Note:

- Select "On" for "User auth." on the [User auth.] tab of "User mng." page (page 87) and "Off" for "Host auth." on the "Host auth." page (page 88) to validate "Access permission".
- When selecting "H.264 recording", select "H.264" for "Recording format" on the [SD memory card] tab and select "Schedule" for "Save trigger". (Page 34)

Step 2

Select days of a week by checking the respective checkboxes.

Step 3

Click [▼] to select the start time and the end time of the schedule.

When not designating time, check the checkbox of "24h".

Step 4

Click the [Set] button after completing the settings.

→ The result will be displayed at the bottom of the window.

Note:

- The schedules displayed at the bottom of the window can be identified by colors assigned to each schedule.

Maintenance of the camera [Maintenance]

System log check, firmware upgrade, status check and initialization of the setup menu can be performed on this page.

The "Maintenance" page has 4 tabs; the [System log] tab, the [Upgrade] tab, [Status] tab and the [Default reset] tab.

Check the system log [System log]

Click the [System log] tab of the "Maintenance" page. (☞ Pages 26 and 27: How to display/operate the setup menu)

Up to 4 000 system logs can be saved on the SD memory card when the SD memory card is inserted after selecting "Use" for "SD memory card" on the [SD memory card] tab (☞ page 33).

When "Not use" is selected for "SD memory card", up to 100 system logs can be saved on the built-in memory of the camera.

When the saved system logs have reached the maximum number, the newer logs will overwrite the older system logs. In this case, the oldest log is the first to be overwritten.

The system logs will be displayed in group of 100 logs each.

When using the SD memory card, the logs will be saved even when the power of the camera is turned off. When not using the SD memory card, the logs will be deleted when the power of the camera is turned off.

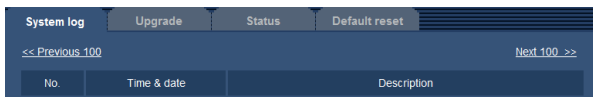

[Next 100 >>]

When clicking "Next 100 >>", the next 100 system logs will be displayed.

[<< Previous 100]

When clicking "<< Previous 100", the previous 100 system logs will be displayed.

[No.]

The serial number of the system log will be displayed.

[Time & date]

Time and date at the error occurrence will be displayed.

Note:

- When "Off" is selected for "Time display format" on the [Basic] tab (☞ page 30), time & date of logs will be displayed in 24-hour format.
-

[Description]

The descriptions about the system log will be displayed.

Refer to page 127 for further information about the system logs.

Upgrade the firmware [Upgrade]

Click the [Upgrade] tab of the "Maintenance" page. (Pages 26 and 27: How to display/operate the setup menu)
The current firmware can be checked and upgraded to the latest version on this page. Contact the dealer for further information about the firmware upgrade.

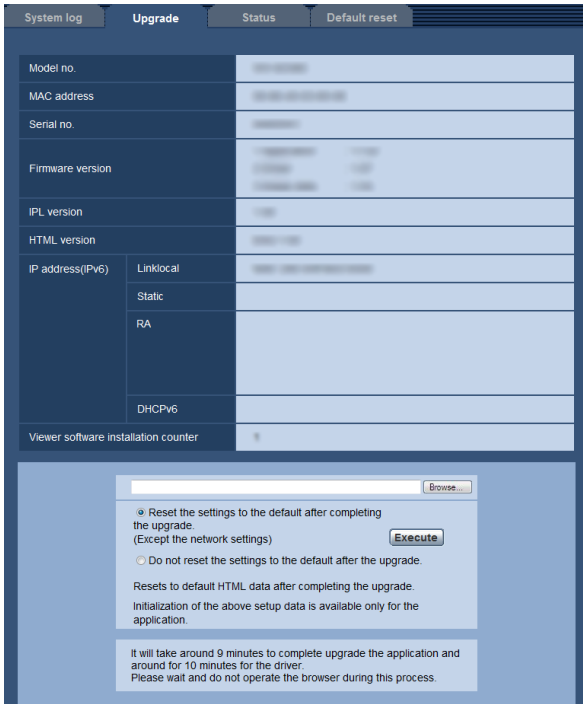

[Model no.], [MAC address], [Serial no.],
[Firmware version], [IPL version], [HTML version],
[IP address(IPv6)], [Viewer software installation
counter]

Information of each item will be displayed.

Step 1

Contact the dealer and download the latest firmware onto a PC.

Important:

- A blank (space) cannot be used for the name of the directory where the downloaded firmware to be saved.

Step 2

Click the [Browse...] button and designate the downloaded firmware.

Step 3

Click the radio button respective to the desired option to determine whether or not to initialize the settings after completing the firmware upgrade.

Note:

- Note that the settings cannot be restored after an initialization is operated.

Step 4

Click the [Execute] button.

- The confirmation window will be displayed. When "Do not reset the settings to the default after the upgrade." is selected, the confirmation window will not be displayed.

Important:

- After completing the upgrade, delete temporary internet files. (☞ Page 137)
 - Upgrade the firmware using a PC in the same subnet as the unit.
 - Follow the instructions from the dealer when upgrading the firmware.
 - Application software upgrade
Use the designated file (extension: img) for the firmware upgrade.
The name of the firmware to be used for the upgrade should be "model name (Use small letters. "WV" is not required.)_xxxxx.img".
* ("xxxxx" indicates the version of the firmware.)
 - Driver software upgrade
Use the designated file (extension: bin) for the firmware upgrade.
The name of the firmware to be used for the upgrade should be "model name (Use small letters. "WV" is not required.)_xxxxx.bin".
* ("xxxxx" indicates the version of the firmware.)
 - Do not turn off the power of the camera during the upgrade process.
 - Do not perform any operation during upgrading and wait until it completes.
 - The following network settings will not be reset when upgrading the firmware after selecting "Reset the settings to the default after completing the upgrade. (Except the network settings)".
On/Off for DHCP, IP address, subnet mask, default gateway, HTTP port, HTTPS port, connection protocol (HTTP/HTTPS), CRT key, server certificate, UPnP setting, line speed, bandwidth control (bit rate), time & date
 - The preset position settings will not be reset when upgrading the firmware after selecting "Reset the settings to the default after completing the upgrade. (Except the network settings)".
 - The viewer software used on each PC should be licensed individually. Refer to your dealer for the software licensing.
-

Check the status [Status]

Click the [Status] tab of the "Maintenance" page. (☞ Pages 26 and 27: How to display/operate the setup menu)
The status of this camera can be checked on this page.

Viewnetcam	
Server	192.168.0.100
Status	OK
Personal(Camera) URL	http://192.168.0.100/

UPnP	
Port number(HTTP)	80
Status	OK
Port number(HTTPS)	443
Status	OK
Router global address	192.168.0.1

Self check	
Hardware1	OK
Hardware2	OK

Hardware information	
Status	OK

[Hardware information]

Information such as how many times the camera has been panning/tilting.

Note:

- Refer to the "Readme" file on the provided CD-ROM for further information about the contents of the displayed statuses (relating to the "Viewnetcam" service, the UPnP function, or the self check). Or refer to our website (<http://panasonic.net/pss/security/support/info.html>) for further information about the supported software.
-

[Viewnetcam]

Server: The URL of the "Viewnetcam" service server will be displayed.

Status: The registration status for the "Viewnetcam" will be displayed.

Personal(Camera) URL: The URL of the camera registered for "Viewnetcam" will be displayed.

[UPnP]

Port number(HTTP), Port number(HTTPS): The port number that is set for UPnP port forwarding will be displayed.

Status: The port forwarding status will be displayed.

Router global address: The global address of router will be displayed.

[Self check]

The self check result of the hardware will be displayed.

Reset the settings/Reboot the camera [Default reset]

Click the [Default reset] tab of the "Maintenance" page. (☞ Pages 26 and 27: How to display/operate the setup menu)

The settings and the HTML data of the camera can be initialized and reboot of the camera can be performed on this page.

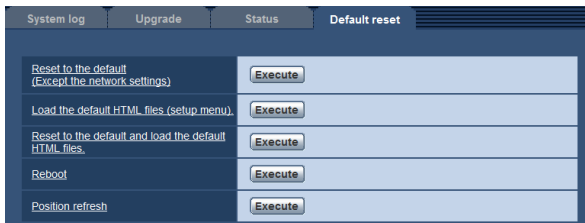

[Reset to the default(Except the network settings)]

Click the [Execute] button to reset the settings to the default. Note that the network settings and preset position settings will not be reset.

It is impossible to operate the camera for around 3 minutes after the initialization.

[Load the default HTML files(setup menu).]

Click the [Execute] button to reset the HTML files to the default.

It is impossible to operate the camera for around 3 minutes after the initialization.

[Reset to the default and load the default HTML files.]

Click the [Execute] button to reset the settings of the camera and the HTML files to the default. Note that the network settings and preset position settings will not be reset.

It is impossible to operate the camera for around 3 minutes after the initialization.

[Reboot]

Click the [Execute] button to reboot the camera. It is impossible to operate the camera for around 2 minutes after rebooting the camera.

[Position refresh]

The camera position can be refreshed. When the camera has moved from the correct home/preset position during normal use, or when it has been inadvertently moved while turning on the power of the camera, use this function to correct the camera position.

It is impossible to operate the camera during the position refresh process (for around 2 minute).

Important:

- The camera position may inadvertently be changed when installing the camera. It is recommended to carry out the position refresh when registering the preset positions after the installation.

Note:

- To initialize the network settings (☞ page 93), turn off the power of the camera, then turn on the power again while holding down the [INITIAL SET] button on the unit for 5 seconds. Wait around 3 minutes after releasing the button. The camera will start up and the settings including the network settings will be initialized. Do not turn off the power of the unit around 3 minutes just after turning on the power.

SW395

- To initialize the network settings (☞ page 93), do the following. Turn off the power of the camera. Turn on the power of the camera after setting the [INITIAL SET] switch to ON, and wait around 3 minutes. The camera will start up and all the settings including the network settings will be initialized. After initialization, turn off the power of the camera again and set the [INITIAL SET] switch to OFF. Do not turn off the power of the camera around 3 minutes just after turning on the power. (SC385) (SC384)
 - The notification function allows users to provide the notification of the error to the specified destination address and an original alarm destination when an error such as no SD memory card insertion after the reboot or a locked SD memory card insertion occurs. (☞ Pages 83 and 84)
-

Viewing Help

If you want to know anything about operation or setup methods on screen, display the "Help" screen.

Displaying the Help screen

Step 1

Click the [Setup] button.

→ The setup screen is displayed.

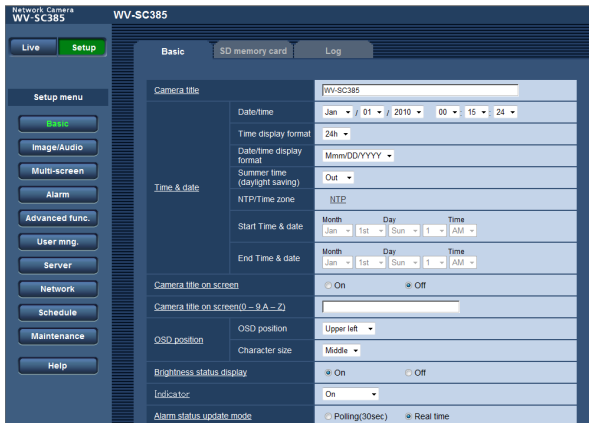

Step 2

Click the [Help] button.

→ The "Help" screen is displayed.



Clicking an underlined item will display the "Help" pop-up window. It is possible to configure the settings while displaying the "Help" pop-up menu.

Step 3

When clicking an item, descriptions corresponding to the clicked item will be displayed.

About the displayed system log

Error indications relating to SMTP

Category	Indication	Description
POP3 server error	Authentication error.	<ul style="list-style-type: none">Entered user name or password may be incorrect. Check if the mail settings are configured correctly.
	Failed to find the POP3 server.	<ul style="list-style-type: none">The IP address of the server may be incorrect. Check if the IP address of the server is configured correctly.The POP3 server may be down. Ask the network administrator.
SMTP server error	Authentication error.	<ul style="list-style-type: none">Entered user name or password may be incorrect. Check if the mail settings are configured correctly.
	Failed to resolve the mail server address from DNS.	<ul style="list-style-type: none">The designated IP address of the DNS may be incorrect. Check if the DNS settings are configured correctly.The DNS server may be down. Ask the network administrator.
	Failed to find the SMTP server.	<ul style="list-style-type: none">The IP address of the server may be incorrect. Check if the IP address of the server is configured correctly.The SMTP server may be down. Ask the network administrator.
Internal error	Undefined error.	<ul style="list-style-type: none">An error occurred in the mail function. Check if the mail settings are configured correctly.

Error indications relating to FTP

Category	Indication	Description
FTP server error	Failed to resolve the FTP server address from DNS.	<ul style="list-style-type: none">The FTP server may be down. Ask the network administrator.
	Failed to find the FTP server.	<ul style="list-style-type: none">The IP address of the server may be incorrect. Check if the IP address of the server is configured correctly.
Connection error	File transfer error.	<ul style="list-style-type: none">The FTP server settings may be incorrect. Check if the FTP settings are configured correctly.
	Passive mode error.	<ul style="list-style-type: none">The settings relating to the indicated item may be incorrect. Check if the FTP settings are configured correctly.
	Log out failed.	<ul style="list-style-type: none">The settings relating to the indicated item may be incorrect. Check if the FTP settings are configured correctly.
	Failed to change the directory.	<ul style="list-style-type: none">The settings relating to the indicated item may be incorrect. Check if the FTP settings are configured correctly.
	User name or password isn't correct.	<ul style="list-style-type: none">The settings relating to the indicated item may be incorrect. Check if the FTP settings are configured correctly.
Internal error	Undefined error.	<ul style="list-style-type: none">An error occurred in the FTP function. Check if the FTP settings are configured correctly.

Error indications relating to "Viewnetcam"

Category	Indication	Description
Viewnetcam server error	Failed to resolve the Viewnetcam server address from DNS.	<ul style="list-style-type: none">• The designated IP address of the DNS may be incorrect. Check if the DNS settings are configured correctly.• The DNS server may be down. Ask the network administrator.
Connection error	No response from the Viewnetcam server. File transfer error.	<ul style="list-style-type: none">• The "Viewnetcam" server may be down. Ask the network administrator.
Internal error	Undefined error.	<ul style="list-style-type: none">• An error relating to the "Viewnetcam" function occurred. Check if the "Viewnetcam" settings are configured correctly.

Error indications relating to Dynamic DNS Update

Category	Indication	Description
DDNS server error	Failed to resolve the DDNS server address from DNS.	<ul style="list-style-type: none">• The designated IP address of the DNS may be incorrect. Check if the DNS settings are configured correctly.• The DNS server may be down. Ask the network administrator.
Connection error	No response from the DDNS server. Same host name has registered.	<ul style="list-style-type: none">• The DDNS server may be down. Ask the network administrator.• The same host name has already been registered in the DDNS server. Check if the DDNS Update settings are configured correctly.
Internal error	Undefined error.	<ul style="list-style-type: none">• An error occurred in the DDNS function. Check if the DDNS Update settings are configured correctly.

Error indications relating to NTP

Category	Indication	Description
Connection error	No response from the NTP server.	<ul style="list-style-type: none">• The IP address of the server may be incorrect. Check if the IP address of the server is configured correctly.• The NTP server may be down. Ask the network administrator.
Internal error	Undefined error.	<ul style="list-style-type: none">• An error occurred in the NTP function. Check if the NTP settings are configured correctly.
Synchronizing with NTP succeeded.	NTP update succeeded.	<ul style="list-style-type: none">• Time correction succeeded.

Log indications relating to HTTPS

Category	Indication	Description
HTTPS	Self-signed Certificate - Generated	<ul style="list-style-type: none">• Generation of the self-signed certificate is complete.
	Self-signed Certificate - Deleted	<ul style="list-style-type: none">• Deletion of the self-signed certificate is complete.
	Certificate Signing Request - Generated	<ul style="list-style-type: none">• Generation of the CSR (Certificate Signing Request) is complete.
	CA Certificate - Installed	<ul style="list-style-type: none">• Installation of the server certificate is complete.
	CA Certificate - Deleted	<ul style="list-style-type: none">• Deletion of the server certificate is complete.
	Previous CRT key - Applied	<ul style="list-style-type: none">• Previous CRT key is applied.
	CRT key - Generated	<ul style="list-style-type: none">• Generation of the CRT key is complete.

Log indications relating to login

Category	Indication	Description
Login	User name or IP address	<ul style="list-style-type: none">• The login user name will be displayed when "On" is selected for "User auth."• The IP address of the PC currently accessing to the camera will be displayed when "On" is selected for "Host auth."

Troubleshooting

Before asking for repairs, check the symptoms with the following table.

Contact your dealer if a problem cannot be solved even after checking and trying the solution in the table or a problem is not described below.

Symptom	Cause/solution	Reference pages
Cannot access from the web browser.	<ul style="list-style-type: none"> Is the LAN cable (category 5 or better, STP*) firmly connected to the network connector of the camera? *PAL model only 	Installation Guide
	<ul style="list-style-type: none"> Is the link indicator lit? When it is not lit, connection to a LAN may not be established or a network may be not working correctly. Check if the cables have any contact failure or if the wiring is correct or not. 	Installation Guide
	<ul style="list-style-type: none"> Is the power of the camera on? Check if the power of the camera is turned on. 	Installation Guide
	<ul style="list-style-type: none"> Are the set IP addresses valid? 	93
	<ul style="list-style-type: none"> Are you accessing the wrong IP address? Check the connection as follows With the Windows command prompt, > ping "IP address of the camera" If there is reply from the camera, the connection is normal. If not, proceed either of the following. <ul style="list-style-type: none"> Reboot the camera and change the IP address by using the Panasonic IP setup software within 20 minutes after the restart. Reboot the camera while holding down the [INITIAL SET] button (or switch) on the camera. The camera will be initialized and the IP address will return to the default setting "192.168.0.10". After the camera is initialized, access the camera and set the IP address again. (When the camera is initialized, all the settings of the camera previously configured on the setup menus will be initialized.) 	–
	<ul style="list-style-type: none"> Is "554" selected for the HTTP port number? For the HTTP port number, select a port number other than the following port numbers used by the camera. The number used by the camera: 20, 21, 23, 25, 42, 53, 67, 68, 69, 110, 123, 161, 162, 443, 554, 995, 10669, 10670, 59000 - 61000 	93

Symptom	Cause/solution	Reference pages
<p>Cannot access from the web browser.</p>	<ul style="list-style-type: none"> • Is the same IP address provided to other devices? Are there contradictions between the address and the network subnet to be accessed? <When the camera and the PC are connected in the same subnet> Are the IP addresses of the camera and the PC set in a common subnet? Or is "Use Proxy Server" for the settings of the web browser checked? When accessing the camera in the same subnet, it is recommended to enter the address of the camera in the "Don't Use Proxy For These Addresses" box. <When the camera and the PC are connected in the different subnet> Is the IP address of the default gateway set for the camera correct? 	-
	<ul style="list-style-type: none"> • Is the name currently used to access the camera different from the name registered for the "Viewnetcam" service? Access the camera again with the registered name. 	113
	<ul style="list-style-type: none"> • Did you access "http://" while using the HTTPS function? To use the HTTPS function, access "https://". It is also necessary to enter the port number. 	106

Symptom	Cause/solution	Reference pages
<p>Cannot access the camera via the Internet.</p>	<ul style="list-style-type: none"> • Are the network settings of the camera correct? Set the default gateway or DNS server address correctly. To use the DDNS service, check that the settings are correct. • Is the setting for "Default gateway" on the "Network" page configured? Or is the setting correct? When communicating using IPv4 Configure the setting for "Default gateway" of "IPv4 network" on the [Network] tab of the setup menu. 	94
	<ul style="list-style-type: none"> • Is the setting of port forwarding configured for the router? To enable the access to the camera via the Internet, it is necessary to perform the port forwarding setting when the router in use does not support the UPnP function. Refer to the manuals provided with the router for further information. • Is UPnP function of the router disabled? Refer to the manuals provided with the router in use to enable the UPnP function. • Is packet filtering set for the router to forbid the access via the Internet? Configure the settings of the router in use to enable the access via the Internet. Refer to the manuals provided with the router for further information about the settings. 	95
	<ul style="list-style-type: none"> • Are you accessing the camera using the local address (the IP address used in a local network)? When accessing the camera, use the global address (or the URL registered in the DDNS service) and the port number of the camera as the IP address to be used in the Internet. 	94, 95, 111
<p>Cannot access the camera via the URL of the "Viewnetcam" service.</p>	<ul style="list-style-type: none"> • Is the global address of camera (or router) notified to the "Viewnetcam" service server? Log into the "My Account" page of "Viewnetcam" website (http://www.viewnetcam.com/) to check the information of the registered camera. If the global address is not displayed for the IP address field, access the camera, and register the user information for the "Viewnetcam" service on the [DDNS] tab on the "Network" page of the setup menu. In addition, check the "Status" of "Viewnetcam" (on the [Status] tab) and the system log (on the [System log] tab) of the "Maintenance" page of the setup menu. 	113, 124

Symptom	Cause/solution	Reference pages
Authentication window is displayed repeatedly.	<ul style="list-style-type: none"> Is the user name and password changed? While accessing the camera, when changing the user name and password of another user logging into the camera on another web browser, the authentication window will be displayed each time the screen is changed or refreshed. 	-
It takes time to display the screen.	<ul style="list-style-type: none"> Are you accessing the camera in the HTTPS mode? In this mode, the refresh interval becomes slower due to decode procession. 	-
	<ul style="list-style-type: none"> Are you accessing another camera in the same local network via a proxy server? Configure the web browser to not use the proxy server. 	-
	<ul style="list-style-type: none"> Are two or more users browsing the camera images simultaneously? It may take time to display the screen or refresh interval may become slower when two or more users browse the camera images simultaneously. 	-
Cannot access the camera from a cellular phone.	<ul style="list-style-type: none"> Is the URL correct? Or is "/mobile" missing at the end of the URL? Check if the URL is entered correctly. When accessing the camera from a cellular phone, it is necessary to enter "/mobile" at the end of the URL that is used for the camera access from a PC. 	14
	<ul style="list-style-type: none"> Is the SSL encryption method different from that of the camera? Select "HTTP" (Do not select "HTTPS") for "HTTPS" - "Connection" on the "Network" page - the [Network] tab, and access the camera again. 	96
	<ul style="list-style-type: none"> Did you access "http://" while using the HTTPS function? To use the HTTPS function, access "https://". It is also necessary to enter the port number. 	106
User registration for the "Viewnetcam" service fails.	<ul style="list-style-type: none"> Is the registered e-mail address correct? When an e-mail with the "Viewnetcam" website link is not received, the registered e-mail address may be incorrect. Visit the "Viewnetcam" website (http://www.viewnetcam.com/) to register the correct e-mail address. 	-

Symptom	Cause/solution	Reference pages
Cannot obtain images on the SD memory card.	<ul style="list-style-type: none"> Is "Allow" selected for "FTP access to camera" on the [Network] tab of "Network" page? It is necessary in advance to select "Allow" for "FTP access to camera" on the [Network] tab of the "Network" page. 	97
	<ul style="list-style-type: none"> Is the entered password correct? Restart the web browser and enter the password again. 	38
	<ul style="list-style-type: none"> Access to the SD memory card may be failed. Restart the web browser and retry to obtain images. 	-
No image is displayed.	<ul style="list-style-type: none"> Is the viewer software installed on the PC? Install the viewer software on a PC. 	5
	<ul style="list-style-type: none"> Is the version of DirectX 9.0c or later? Check the version of DirectX as follows. (1) Select "Run..." from the start menu of Windows®. (2) Enter "dxdiag" in the displayed dialog box and click the [OK] button. If the version of DirectX is older than 9.0c, upgrade it. 	-
	<ul style="list-style-type: none"> Is the cellular phone in use support the 320×240 resolution? Or is the image data size too big to display images on the cellular phone? Refer to the manuals provided with the cellular phone in use for the restrictions of image data sizes. 	-
No image is displayed. / Older images or logs are displayed.	<ul style="list-style-type: none"> When "Every time I visit the webpage" is not selected for "Check for newer versions of stored pages:" in the "Temporary Internet Files" section, images sometimes may not be displayed on the "Live" page. In this case, do the following. (1) Select "Internet Options..." from "Tools" on the menu bar of Internet Explorer®. The "Internet Options" window will be displayed. (2) When using Internet Explorer 7.0, Internet Explorer 8.0 Click the [Settings] button in the "Browsing history" section on the [General] tab, and then select "Every time I visit the webpage" for "Check for newer versions of stored pages:" in the "Temporary Internet Files" section on the "Temporary Internet Files and History Settings" window. When using Internet Explorer 6.0 Click the [Settings...] button in the "Temporary Internet files" section on the [General] tab, and then select "Every visit to the page" for "Check for newer versions of stored pages:" on the "Settings" window. 	-

Symptom	Cause/solution	Reference pages
Images are displayed blurry.	<ul style="list-style-type: none"> Is there dust or dirt on the dome section? Check if there is no dust or dirt on the dome section. When defocusing is caused by the camera position being moved, carry out the position refresh to correct the focus. 	Installation Guide
When using an optional inner cover, upper side of images are hidden (become black) when the tilt angle of the camera is almost level.	<ul style="list-style-type: none"> This is not malfunction. (This is caused by the shape of the inner cover WV-Q157 or an inner cover provided to an optional bracket.) In this case, images may also be washed out depending on the photographic subject when "On" is selected for "AGC" on the setup menu. 	Installation Guide
Cannot adjust the focus correctly.	<ul style="list-style-type: none"> Is there dust or dirt on the dome section? Clean the dome section. 	Installation Guide
	<ul style="list-style-type: none"> Are photographic subjects hard to focus on with the auto focus function? Adjust the focus manually. 	9
The image is not being refreshed.	<ul style="list-style-type: none"> Depending on the version of your browser, there might be difficulties refreshing the picture, etc. 	Installation Guide
	<ul style="list-style-type: none"> Depending on the traffic of the network or the concentration of access to the camera, there might be difficulties displaying the camera picture. Request the camera picture using the web browser such as by pressing the [F5] key, etc. 	–
No image is displayed (or too dark).	<ul style="list-style-type: none"> Is the brightness setting set at an appropriate level? Click the [Normal] button of [Brightness]. 	11
Images are displayed washed out.	<ul style="list-style-type: none"> Is the brightness setting set at an appropriate level? Click the [Normal] button of [Brightness]. 	11
Flicker appears on the screen.	<ul style="list-style-type: none"> When flicker occurs frequently, select "Indoor scene" for "Light control mode". 	60, 64
The camera does not move onto the preset position exactly.	<ul style="list-style-type: none"> When the camera position is moved from the preset position after turning on the power of the camera, execute the position refresh function from the [Default reset] tab of the "Maintenance" page. When "Position refresh" is set for the created schedule, the camera position will be corrected periodically. 	120,125
	<ul style="list-style-type: none"> Is any part of the camera worn out? When the camera does not move to the exact position frequently, the driving parts may be worn out. Contact the dealer for assistance. 	–

Symptom	Cause/solution	Reference pages
The camera does not automatically move to the previous position when turning on the power of the camera.	<ul style="list-style-type: none"> If the camera always moves to a specific position after turning on the power of the camera, register that position as the home position when convenient. The camera will automatically move to the registered position using the self return function when turning on the power of the camera. 	56
The AUTO MODE (Off, home position, auto track, auto pan, preset sequence) of the camera changes.	<ul style="list-style-type: none"> Check the settings for the self return function. 	56
Images cannot be saved on the SD memory card. Failed to write/read data on the SD memory card.	<ul style="list-style-type: none"> Is the SD memory card inserted correctly? Check if the SD memory card is inserted correctly. 	Installation Guide
	<ul style="list-style-type: none"> Is the SD memory card formatted? Format the SD memory card. 	36
	<ul style="list-style-type: none"> Isn't the write protect switch set to "LOCK"? When the write protect switch is set to "LOCK", available size/total size indication of the SD memory card to be displayed on the [SD memory card] tab will be "*****KB/*****KB". 	-
	<ul style="list-style-type: none"> Is "-----KB/-----KB" displayed on "Remaining capacity" of the [SD memory card] tab? Format the SD memory card. 	36
	<ul style="list-style-type: none"> Is any recognition error received when the "Diag." of "Mail notification" or "Panasonic alarm protocol notification" is used? Format the SD memory card. 	36, 83, 84
	<ul style="list-style-type: none"> Isn't the SD memory card out of order? There are limited times to overwrite on an SD memory card. When frequently overwritten, it may be at the end of product life. It is recommended to replace the SD memory card. 	-
Cannot transmit audio to the camera.	<ul style="list-style-type: none"> Are the microphone and the speaker connected correctly and firmly? Confirm that they are connected correctly and firmly. 	Installation Guide
	<ul style="list-style-type: none"> Is the viewer software installed on the PC? Confirm that the viewer software "Network Camera View 4S" is installed. 	5
Audio is not output from other i-PRO Series products (such as a network disk recorder or PC software package).	<ul style="list-style-type: none"> Some of these i-PRO Series products may not support "G.711". Set the audio encoding format of the products to "G.726 (32 kbps)." 	72

Symptom	Cause/solution	Reference pages
The alarm occurrence indication button, the [AUX] buttons and the SD recording status indicator on the "Live" page do not display the current status in real time.	<ul style="list-style-type: none"> Is the viewer software installed on the PC? Confirm that the viewer software "Network Camera View 4S" is installed. 	5
	<ul style="list-style-type: none"> Is "Real time" selected for "Alarm status update mode"? 	32
No image is displayed on the "Live" page.	<ul style="list-style-type: none"> Press the [F5] key on the keyboard of the PC or click the [Live] button. 	8
Shortcut icon of the camera is not displayed on "My Network Places" of the PC.	<ul style="list-style-type: none"> Is the Windows component of UPnP added? Add the component to the PC in use. 	95
Cannot download the log list.	<ul style="list-style-type: none"> Download of files using Internet Explorer may be disabled. Click "Internet Options" on the Tool menu of Internet Explorer, and [Security] tab. Then, click the [Custom Level...] button to open the "Security Setting" window. Under "Download", select "Enable" for "Automatic prompting for file downloads". Click the [OK] button. The "Warning" window will be displayed. Click the [Yes] button. 	-
Images are not displayed or not refreshed smoothly.	<ul style="list-style-type: none"> Delete temporary internet files as follows. (1) Select "Internet Options..." under "Tools" on the menu bar of Internet Explorer. The "Internet Options" window will be displayed. (2) Click the [Delete Files...] button in the "Temporary Internet files" section on the [General] tab. 	-
	<ul style="list-style-type: none"> The firewall function of the anti-virus software may be filtering the port of the camera. Exclude the port number of the camera from the list of the port numbers to be filtered by the anti-virus software. 	-
No indicator lights.	<ul style="list-style-type: none"> Is "Off" selected for "Indicator" on the "Basic" page? Select "On" for "Indicator". 	31
H.264 (or MPEG-4) images are not displayed.	<ul style="list-style-type: none"> When "Network Camera View 4S" is deleted from a PC on which both the viewer software "Network Camera View 3" and "Network Camera View 4" are installed, H.264 (or MPEG-4) images may not be displayed. In this case, delete "Network Camera View 3" from the PC and then install "Network Camera View 4S". 	5

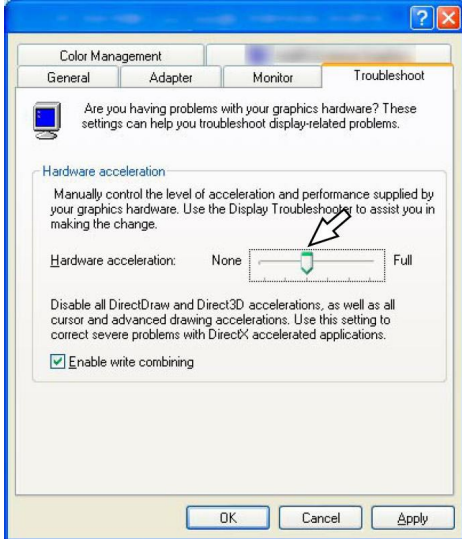
Symptom	Cause/solution	Reference pages
<p>When displaying H.264 (or MPEG-4) images on two or more web browser windows, images from two or more cameras are displayed in sequence on a single browser window.</p>	<ul style="list-style-type: none"> • This may occur due to the display adapter and driver combination. <p>When this has occurred, first update the driver of the display adapter to the latest version.</p> <p>If updating the driver does not solve the problem, adjust the hardware acceleration as follows.</p> <p>The following are descriptions for when Windows XP is installed on the PC in use.</p> <ol style="list-style-type: none"> (1) Right-click on the desktop and select "Properties" from the displayed pop-up menu. (2) Select "Settings" from "Display Properties", and then click the [Advanced] button. (3) Click the [Troubleshoot] tab and disable the DirectDraw acceleration by adjusting the level of Hardware acceleration.  <p>The screenshot shows the 'Troubleshoot' tab of the Windows XP Display Properties dialog box. It features a 'Hardware acceleration' slider set to 'None'. A mouse cursor is positioned over the slider. Below the slider, there is a checkbox for 'Enable write combining' which is checked. The dialog box also includes 'OK', 'Cancel', and 'Apply' buttons at the bottom.</p>	<p>-</p>

Depending on the OS installed on the PC, the following may occur. Follow the instructions below when the following has occurred. By performing the following solutions, other applications and the security level may not be affected.

The "Information Bar" expressed in the following symptom and solutions will be displayed just below the address bar only when there is information to communicate.



Symptom	Cause/solution	Reference pages
<p>The following message is displayed on the information bar. "Pop-up blocked. To see this pop-up or additional options, click here..."</p>	<ul style="list-style-type: none"> Click the information bar and select "Always Allow Pop-ups from This Site...". The dialog window saying "Allow pop-ups from this site?" will be displayed. Click the [Yes] button. 	<p>–</p>
<p>The following message is displayed on the information bar. "This site might require the following Active X control 'nwc4Ssetup.exe' from 'Panasonic System Networks Co.,Ltd.'. Click here to install..."</p>	<ul style="list-style-type: none"> Click the information bar and select "Install Active X Control". The "Security Warning" window will be displayed. Click the "Install" button on the displayed "Security Warning" window. 	<p>–</p>

Symptom	Cause/solution	Reference pages
<p>An unnecessary status bar or scroll bar is displayed on the pop-up window.</p>	<ul style="list-style-type: none"> Click "Internet Options..." under "Tools" of the menu bar of Internet Explorer, and then click the [Security] tab. Click "Internet" in the "Select a Web content zone to specify its security settings:" section. Then, click the [Custom Level...] button to open the "Security Setting" window. Under "Miscellaneous", select "Enable" for "Allow script-initiated windows without size or position constraints". Click the [OK] button. When the warning window is displayed, click the [Yes] button. 	<p>–</p>
<p>Images are not fit in the frames.</p>	<ul style="list-style-type: none"> When "120 DPI" is not selected for "DPI setting", they may not be displayed correctly. Click the "Settings" tab on the "Properties" window of "Screen" (in the control panel), and then click the [Advanced] button. Change the "DPI setting" to "Large size (120 DPI)". 	<p>–</p>

Directory structure of drive B

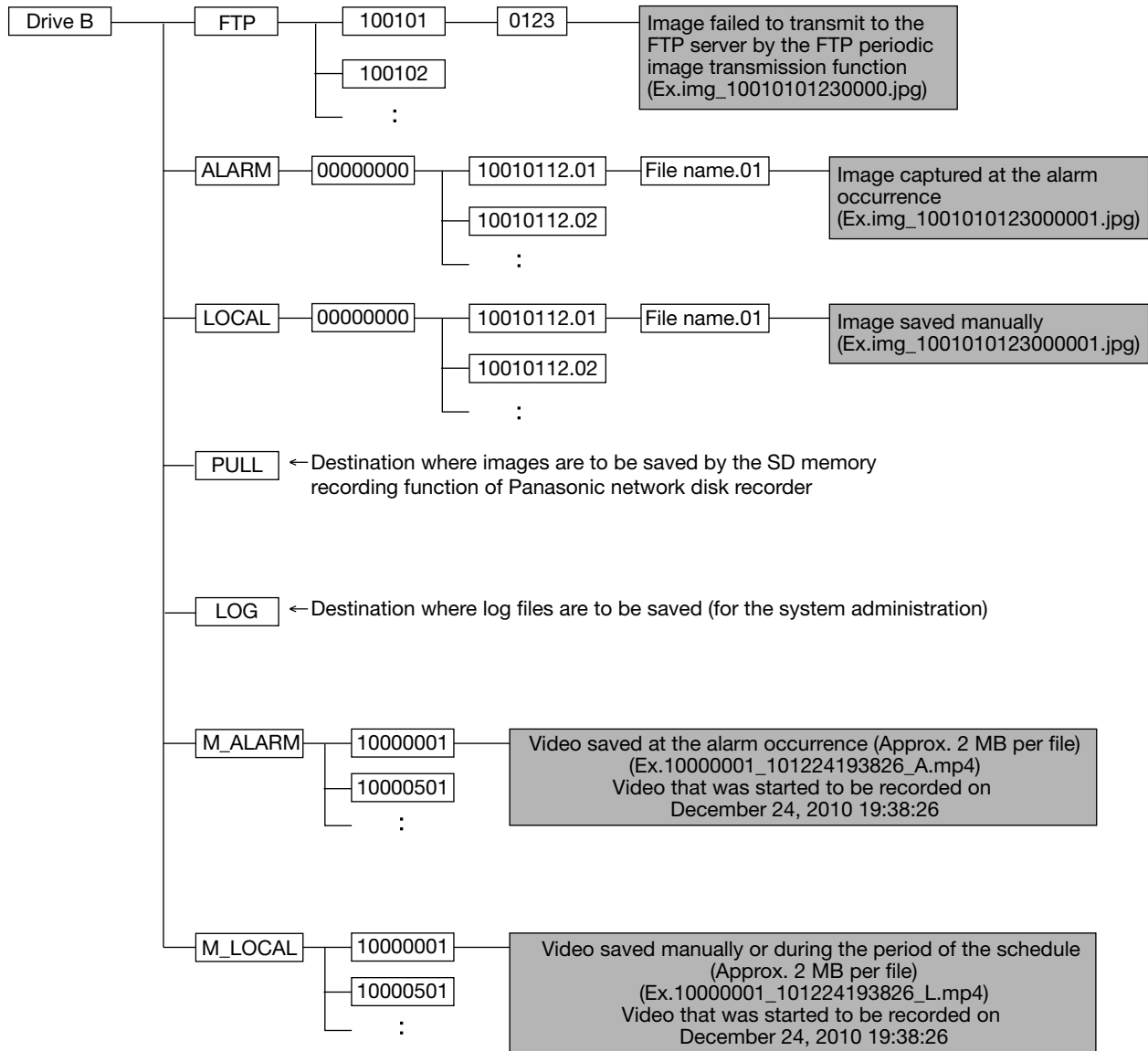

For U.S. and Canada:

**Panasonic System Networks Company of America,
Unit of Panasonic Corporation of North America**

www.panasonic.com/business/
For customer support, call 1.800.528.6747
Three Panasonic Way, Secaucus, New Jersey 07094 U.S.A.

Panasonic Canada Inc.

5770 Ambler Drive, Mississauga, Ontario, L4W 2T3 Canada
(905)624-5010
www.panasonic.ca

For Europe and other countries:

Panasonic Corporation

<http://panasonic.net>

Importer's name and address to follow EU rules:

Panasonic Testing Centre
Panasonic Marketing Europe GmbH
Winsbergring 15, 22525 Hamburg F.R.Germany