

# Isolated RS485/232 Interface Board for S7-200 SMART

## SB CM01+ User Manual

SB CM01+ is an isolated RS485/232 interface board developed for Siemens S7-200 SMART PLC. It adopts the most advanced magnetic isolators to isolate RS485 and RS232 signals, and is designed with lightning protection devices and PTC overcurrent protective device, solving the grounding interference and interface burning problem of various RS485/232 nodes resulting from different ground potential. It's a good choice to improve reliability and stability of the communication (particularly noticeable when communicating with the inverter) and extend the communication distance.

Isolated SB CM01+ interface board is completely compatible to Siemens non-isolated interface board SB CM01 and can be directly replaced. Its built-in terminal resistance and biasing resistor make it easier for wiring. The following table shows the differences between these two interface boards.

Interface board	Siemens non-isolated SB CM01	Isolated SB CM01+
Performance comparison		
RS232 maximum communication distance	10m	30m
RS485 maximum communication distance (187.5Ks)	50m	1000m
RS485 terminal resistance and biasing resistor	No, external connection required	Yes, switch to enable
RS485 lightning protection and overcurrent protection	No	Yes
Number of terminal	6 cores with 5V bias voltage output for external terminal resistance and biasing resistor	5 cores without bias voltage output and built-in terminal resistance and biasing resistor.
Plastic casing	Yes	No, use the plastic casing of CPU body
Power consumption	0.5W	0.7W

### Main technical parameters of SB CM01+:

- Isolation voltage: 1000VDC.
- RS232 port with surge protection.
- RS485 port with lightning protective device. Repeatable surge capacity:  $I_{pp}=100A$  (10/700us, 4KV)  
Standard complied: ITU-TK20/21, VDE 0433.  $\pm 15KV$  ESD (static electricity) protection.
- Recoverable overcurrent protection: RS485 port can withstand the sustained overcurrent caused by voltage up to 60V.
- Maximum communication distance of RS232: 30m, maximum communication distance of RS485 (187.5K): 1000m.
- Built-in RS485 terminal resistance and biasing resistor, switch to enable
- Power consumption: 0.7W. Operating temperature:  $-40\sim+85^{\circ}C$ . Dimension W\*H\*D(mm): 35\*52.2\*16(in casing).

## SB CM01+ configuration and functional blocks diagram:

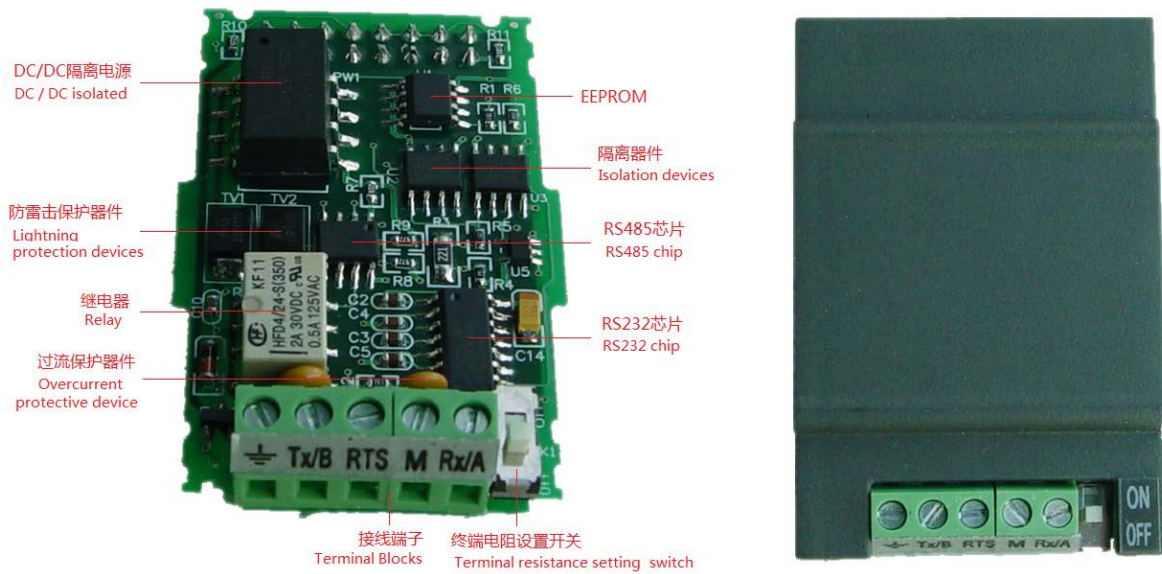

Connect S7-200 SMART PLC and the computer with network cables before using SB CM01+, and set the interface type, address, baud rate and other parameters of the signal interface board SB CM01+ in STEP 7-MicroWIN SMART software.

When configuring SB CM01+ as the RS232 interface, terminal resistance setting switch is invalid.

When configuring SB CM01+ as RS485 interface, there is no terminal resistance and biasing resistor if the switch is "off". If it's "on", a 220  $\Omega$  terminal resistance and two 390  $\Omega$  biasing resistor will be connected internally.

Terminal signal definition on SB CM01+ interface board

Appearance	Terminal number	Signal name	Description
	1	Shield grounding	Case earthing
	2	Tx/B	RS232-Tx (out) /RS485-B (signal positive)
	3	RTS	Request to send (TTL electrical level)
	4	M	Signal earthing
	5	Rx/A	RS232-Rx (in) /RS485-A (signal negative)

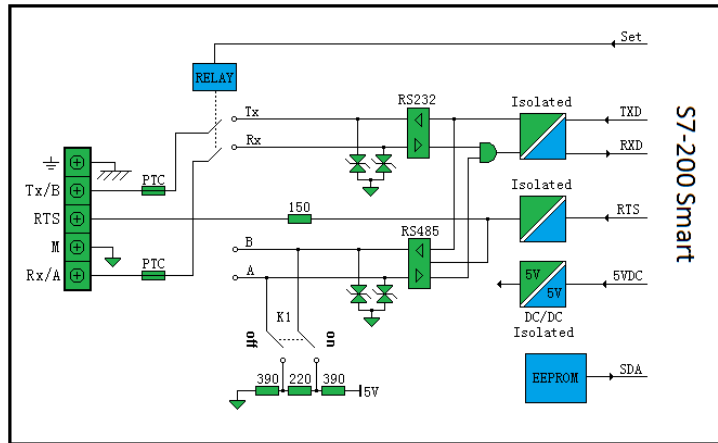

SB CM01+ functional block diagram

**SB CM01+ installation:**

SB CM01+ is not supplied with casing, it needs to use the supplied of S7-200 SMART CPU body. Switch off PLC power, remove the supplied SB CM01 casing of CPU, insert the SB CM01+ interface board on the casing and then insert it to the CPU. After hearing a clicking sound, the SB CM01+ is connected correctly with CPU.

The installation and software programming of isolated SB CM01+ are completely identical with those of Siemens non-isolated SB CM01. When it's located on the two terminal nodes of RS485 network segment and the terminal resistance setting switch is "on", it avoids the trouble to externally connect the terminal resistance and biasing resistor with Siemens SB CM01 as the terminal node.

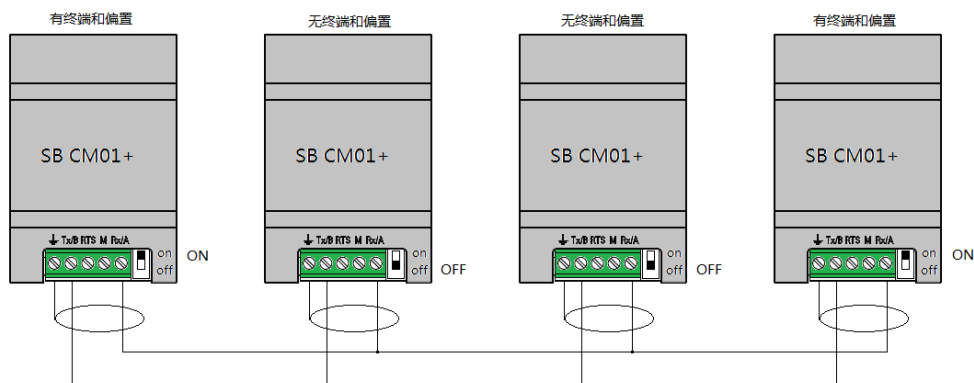

For the detailed application method of SB CM01+, please refer to the SB CM01 part in Siemens S7-200 SMART System Manual.