

63FBHD-T product information sheet

Product Specifications

Fits most: 37" to 63" flat panels

Supports up to: 200 lbs (90.7 kg)

Tilts: -5° to +15°

Mounting profile: 2.9" (74 mm)

Mounting: double-stud

Universal & VESA compliant: 75x75, 100x100, 100x200, 200x200, 200x300, 300x400, 400x400, 400x600, 400x800, 600x800

Color: Black and Silver

Product Benefits

- Universal rails for greater panel compatibility
- Includes cable management cover for routing wires
- Tension adjustment for variable tilt
- Sliding lateral on-wall adjustment
- Open architecture for trim out
- Lift n' Lock™ for easy installation
- Locking system for added safety
- Anti-theft security feature
- Includes installation template
- Includes complete Grade 5 hardware kit
- Includes extension rods and rails



All Fastback HD mounts come with an installation template to ensure a quick, easy and accurate installation.



Series



17FBHD-T



37FBHD-T

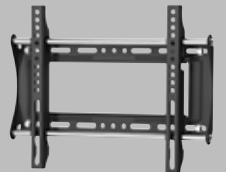

37FBHD-F

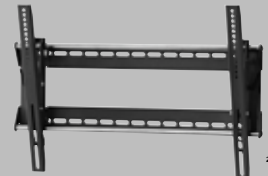

63FBHD-T



54FBHD-F



Recipient of the 2004 CEDIA
Manufacturers' Excellence Award



Dedicated to being a one-stop-shop for professional products, OmniMount remains on the cutting edge of product innovation. That's why we're the natural choice for any professional, industrial or commercial application. As a step-up from the Fastbacks, the Fastback HD Series is a full line of fixed and tilt mounts offering simple and reliable universal mounting solutions for quick and easy installs. The 63FBHD-T is a solid choice for high-volume jobs requiring a heavy-duty universal large/extra large tilt mount.



63FBHD-T technical data sheet



Dedicated to being a one-stop-shop for professional products, OmniMount remains on the cutting edge of product innovation. That's why we're the natural choice for any professional, industrial or commercial application. As a step-up from the Fastbacks, the Fastback HD Series is a full line of fixed and tilt mounts offering simple and reliable universal mounting solutions for quick and easy installs. The 63FBHD-T is a solid choice for high-volume jobs requiring a heavy-duty universal large/extra large tilt mount.

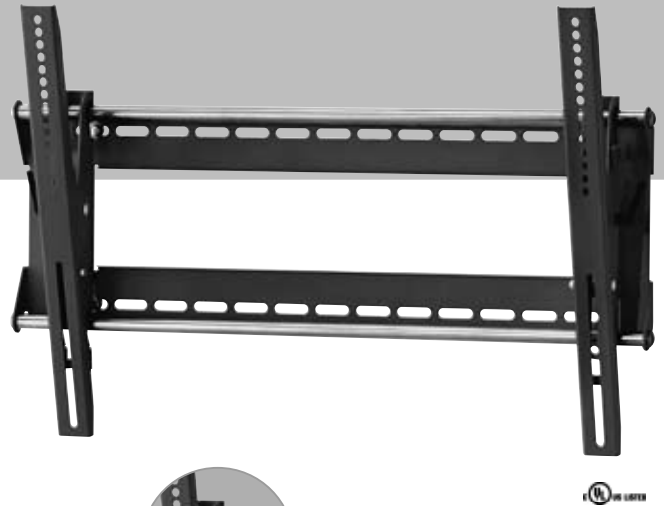

Black

Silver

Product Specifications

Fits most: 37" to 63" flat panels

Supports up to: 200 lbs (90.7 kg)

Tilts: -5° to +15°

Mounting profile: 2.9" (74 mm)

Mounting: double-stud

Universal & VESA compliant: 75x75, 100x100, 100x200, 200x200, 200x300, 300x400, 400x400, 400x600, 400x800, 600x800

Color: Black and Silver

Product Benefits

- Universal rails for greater panel compatibility
- Includes cable management cover for routing wires
- Tension adjustment for variable tilt
- Sliding lateral on-wall adjustment
- Open architecture for trim out
- Lift n' Lock™ for easy installation
- Locking system for added safety
- Anti-theft security feature
- Includes installation template
- Includes complete Grade 5 hardware kit
- Includes extension rods and rails

	Color	Stock Code	Packaging UPC	MC UPC
Americas	Black	1002801PRO	728901016271	NA
International	Black	NA	NA	NA
Americas	Silver	1002555PRO	728901016288	NA
International	Silver	NA	NA	NA

Box Contents	Qty
Wall plate	1
Vertical tilt rail	2
Cable management cover	1
Horizontal extension rail	4
Vertical extension rail	2

	Dimensions WxDxH inches (mm)	Wt lbs (kg)
Product Box	11.9 x 32.8 x 5.4 (302x832x137)	25.7 (11.7)
Master Carton	NA	NA

Box Contents	Qty
Installation template	1
Complete mount installation hardware kit	1
Complete panel attachment hardware kit	1
Instruction manual	1
Flat panel compatibility chart	1

63FBHD-T line drawing

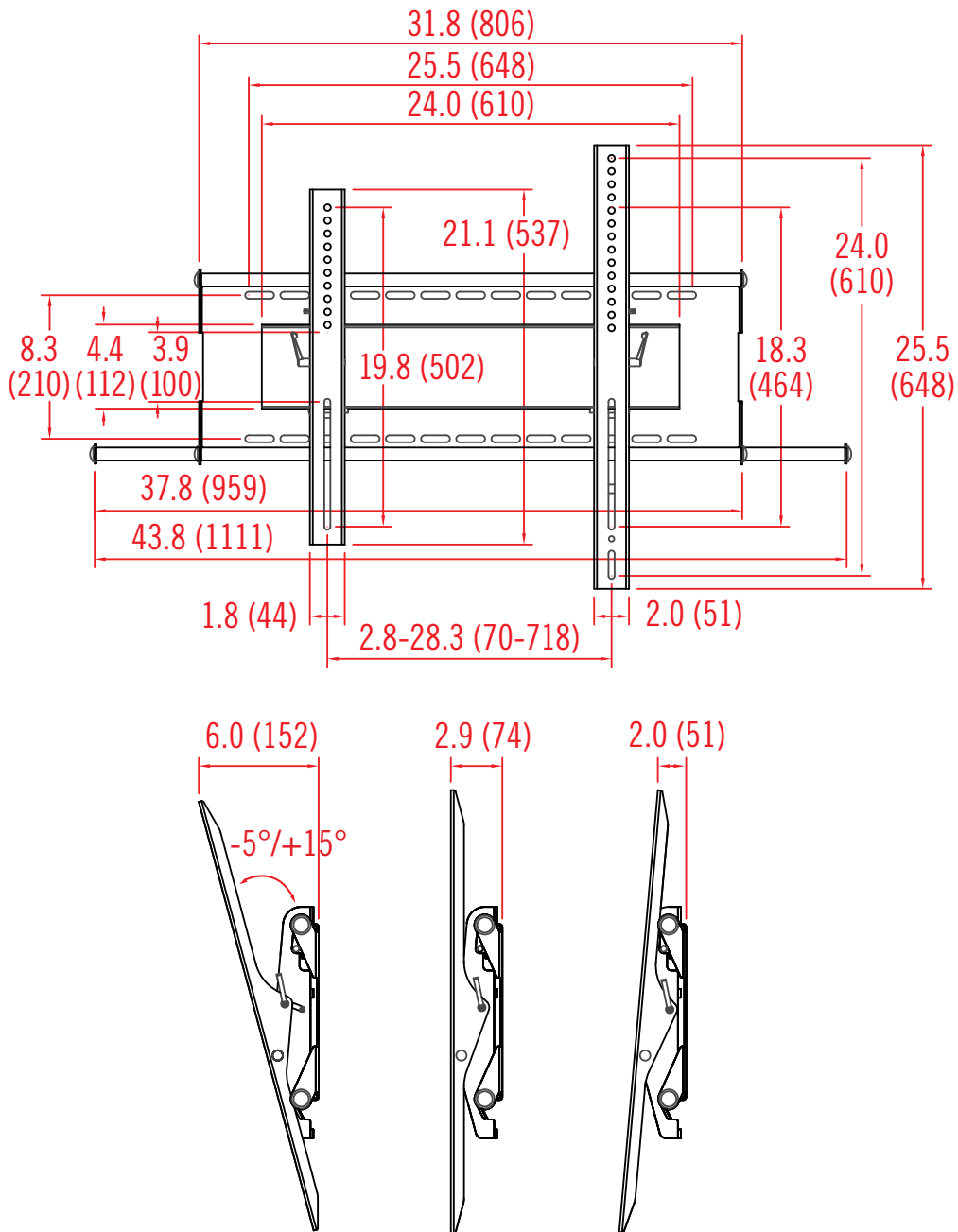

inches (mm)

Architects Specifications

The flat panel wall mount shall be an OmniMount model 63FBHD-T and shall be located where indicated on the plans. It shall be constructed of sheet metal with $-5/+15^{\circ}$ adjustable forward tilt. Assembly and installation shall be done according to instructions provided by the manufacturer.