

54FB-T product information sheet

Product Specifications

Fits most: 37" to 60" flat panels

Supports up to: 175 lbs (79.4 kg)

Tilt: 0 to +15°

Mounting profile: 2.7" (69mm)

Universal & VESA compliant: 75x75, 100x100, 100x200, 200x200, 200x300, 300x400, 400x400, 400x600

Mounting: Double-stud

Color: Platinum and Black

Product Benefits

- Universal rails for greater panel compatibility
- Low profile design
- Sliding lateral on-wall adjustment
- Tension adjustment for variable tilt
- Open architecture for easy trim out
- Lift n' Lock™ for quick installation
- Locking system for added safety
- Anti-theft security feature
- Includes complete Grade 5 hardware kit

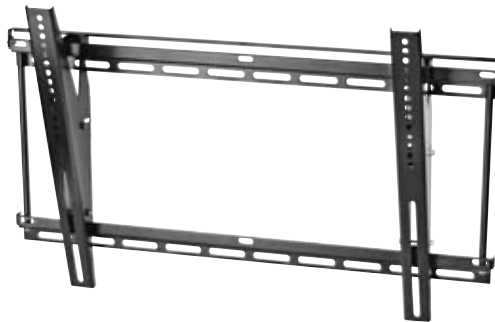

Keeping ease of installation in mind, the 54FB-T was designed to be installed in a few simple steps.

Series



37FB-T



37FB-F



54FB-T



54FB-F

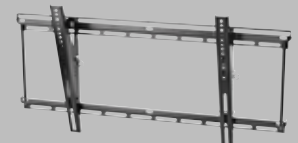

63FB-T

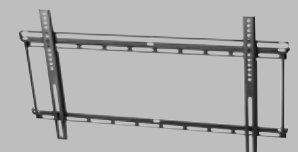

63FB-F



Dedicated to being a one-stop-shop for professional products, OmniMount remains on the cutting edge of product innovation. That's why we're the natural choice for any professional, industrial or commercial application. The Fastback Series offers both fixed and tilt universal mounting solutions that are designed for quick and easy installs. The 54FB-T is the ideal mount for budget-conscious customers or high-volume jobs requiring a dependable large tilt mount.



54FB-T technical data sheet



Dedicated to being a one-stop-shop for professional products, OmniMount remains on the cutting edge of product innovation. That's why we're the natural choice for any professional, industrial or commercial application. The Fastback Series offers both fixed and tilt universal mounting solutions that are designed for quick and easy installs. The 54FB-T is the ideal mount for budget-conscious customers or high-volume jobs requiring a dependable large tilt mount.

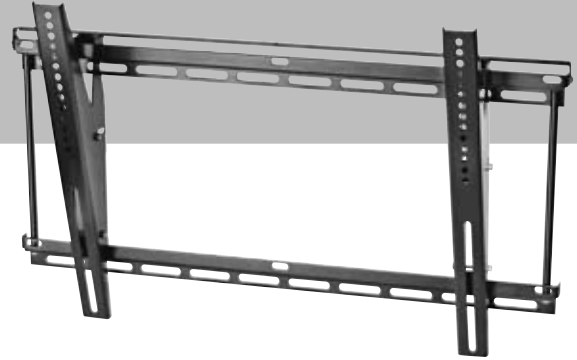

Product Specifications

Fits most: 37" to 60" flat panels

Supports up to: 175 lbs (79.4 kg)

Tilt: 0 to +15°

Mounting profile: 2.7" (69mm)

Universal & VESA Compliant: 75x75, 100x100, 100x200, 200x200, 200x300, 300x400, 400x400, 400x600

Mounting: Double-stud

Color: Black and Silver



Product Benefits

- Universal rails for greater panel compatibility
- Low profile design
- Sliding lateral on-wall adjustment
- Tension adjustment for variable tilt
- Open architecture for easy trim out
- Lift n' Lock™ for quick installation
- Locking system for added safety
- Anti-theft security feature
- Includes complete Grade 5 hardware kit

	Color	Stock Code	Packaging UPC	MC UPC
Americas	Black	1002889PRO	728901015014	728901708312
International	Black	NA	NA	NA
Americas	Silver	1002888PRO	728901014284	728901707452
International	Silver	NA	NA	NA

	Dimensions WxDxH Inches (mm)	Wt lbs (kg)
Product Box	32.3 x 21 x 2.6 (846x368x70)	18.9 (8.6)
Master Carton	34.5 x 15.3 x 6.6 (876x387x167)	37.7 (17.1)

Box Contents	Qty
Wall plate	1
Tilt rail	2
Locking bar	1
Complete mount installation hardware kit	1
Complete panel attachment hardware kit	1
Instruction manual	1
Flat panel compatibility chart	1

54FB-T line drawing

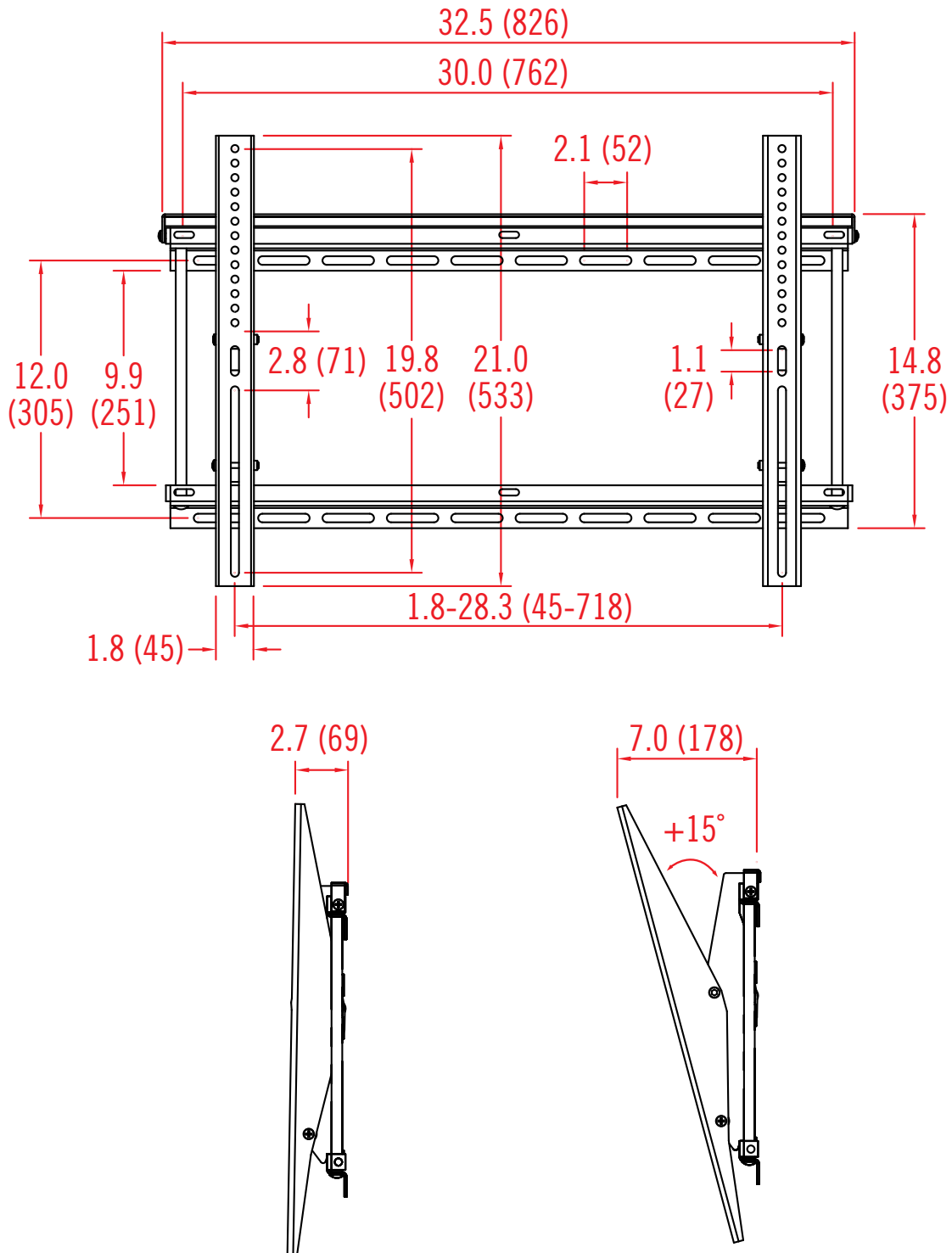

inches (mm)

Architects Specifications

The flat panel wall mount shall be an OmniMount model 54FB-T and shall be located where indicated on the plans. It shall be constructed of sheet metal with +15° adjustable forward tilt. Assembly and installation shall be done according to instructions provided by the manufacturer.