



INSTALLATION INSTRUCTIONS FOR PARTS 95-3305 or 99-3305

APPLICATIONS

See application list inside

GM multi-kit 2006-up 95-3305 or 99-3305

KIT FEATURES

95-3305:

- Double DIN radio provision
- Stacked ISO radio provision

99-3305:

- DIN radio provision with pocket
- ISO radio provision with pocket



KIT COMPONENTS

95-3305: • A1) Double DIN trim plate • B1) Double DIN bracket

99-3305: • A2) Radio housing • B2) ISO brackets • C2) Trim plate

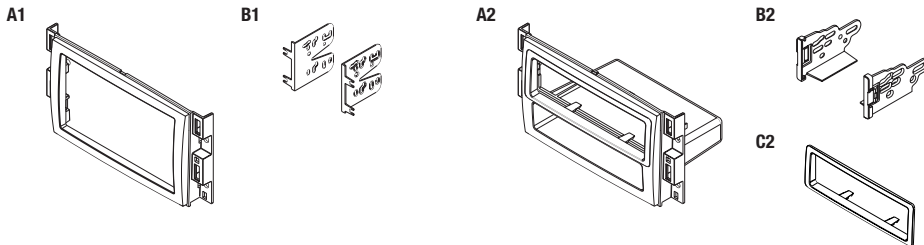

WIRING & ANTENNA CONNECTIONS (sold separately)

Wiring Harness:

- GMOS-LAN-01 - GM LAN 29 interface 2006-up
- GMOS-LAN-02 - GM LAN 29 amplified OnStar interface 2006-up
- GMOS-LAN-07 - GM LAN amplified OnStar interface 2012-up (equipped with factory NAV)

Antenna Adapter:

- 40-CR10 - Chrysler/GM antenna adapter 2002-up

TOOLS REQUIRED

- Small flat blade screwdriver • Panel removal tool
- Phillips screwdriver • Socket set • Torx driver
- Allen wrench

CAUTION: Metra recommends disconnecting the negative battery terminal before beginning any installation. All accessories, switches, and especially air bag indicator lights must be plugged in before reconnecting the battery or cycling the ignition.

NOTE: Refer to the instructions included with the aftermarket radio.



95-3305 or 99-3305

Applications

Buick		GMC	
Enclave	2008-2012	Acadia	2007-2012
Lucerne	2006-2011	Savanna	2008-up
Chevrolet		Sierra**	2007-up
Avalanche	2007-up	Yukon XL Denali	2007-up
Equinox	2007-2009	Yukon/XL	2007-up
Express Van	2008-up	Hummer	
Impala	2006-up	H2	2008-2009
Monte Carlo	2006-2007	Pontiac	
Silverado**	2007-up	Torrent	2007-2009
Suburban	2007-up	Saturn	
Tahoe	2007-up	Outlook	2007-2010
Traverse	2009-up	Vue	2008-2010
Captiva Sport	2012	Suzuki	
		XL-7	2007-2009

**Excluding classic models

Table of Contents

Dash Disassembly	
- Buick Enclave 2008-2012	6
- Buick Lucerne 2006-2011	3
- Chevrolet Avalanche 2007-up	3

Table of Contents

- Chevrolet Captiva Sport 2012	7
- Chevrolet Equinox 2007-2009	5-6
- Chevrolet Express Van (full size) 2008-up	4
- Chevrolet Impala 2006-up	3
- Chevrolet Monte Carlo 2006-2007	3
- Chevrolet Silverado Pickup (excluding classic models) 2007-up	3
- Chevrolet Suburban 2007-up	3
- Chevrolet Tahoe 2007-up	3
- Chevrolet Traverse 2009-up	6
- GMC Acadia 2007-2012	6
- GMC Savanna Van (full size) 2008-2010	4
- GMC Sierra (excluding classic models) 2007-up	3
- GMC Yukon/Yukon XL/Yukon XL Denali 2007-up	3
- Hummer H2 2008-2009	7
- Pontiac Torrent 2007-2009	5-6
- Saturn Outlook 2007-2010	6
- Saturn Vue 2008-2010	7
- Suzuki XL-7 2007-2009	4-5
Kit Assembly	
- Double DIN radio provision	8
- Stacked ISO radio provision	9
- DIN radio provision with pocket	10
- ISO radio provision with pocket	11



Dash Disassembly

Buick Lucerne 2006-2011, Chevy Impala 2006-up, Monte Carlo 2006-2007

1. Unclip and remove the trim panel around radio and A/C control. (Figure A)
2. Remove (6) 9/32" screws to extract radio and A/C control from sub dash. (Figure B)

Continue to kit assembly



(Figure A)

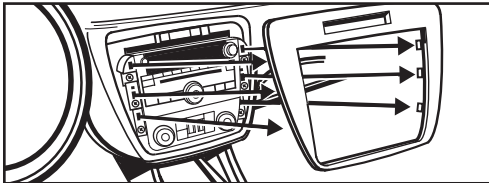

(Figure B)

Chevy Avalanche/Tahoe/Suburban/Silverado (excluding classic models) 2007-up, GMC Yukon/Sierra (excluding classic models) 2007-up

1. Unclip and remove radio trim panel. (Figure A)
2. Remove (2) 8 mm screws securing switch panel below climate controls. Unplug and remove switch panel. (Figure B)
3. Remove (2) 8 mm screws securing climate controls. Unplug and remove climate controls. (Figure B)
4. Remove (4) 9/32" screws securing radio. Unplug and remove the radio. (Figure C)

Continue to kit assembly

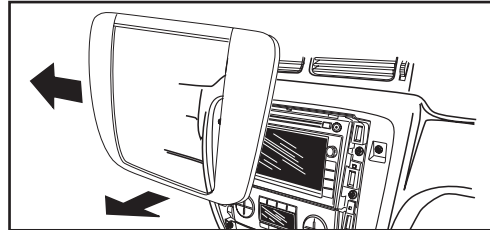

(Figure A)

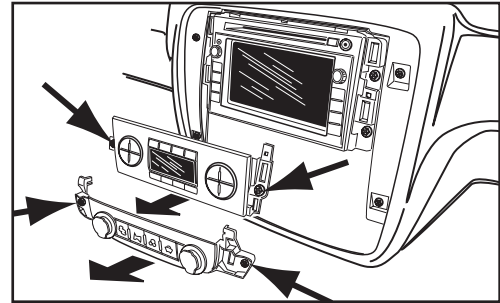

(Figure B)

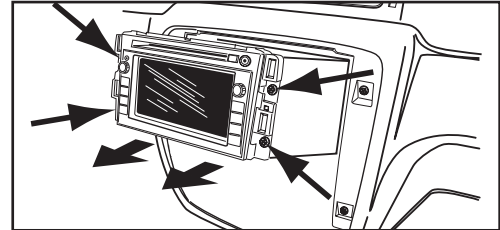

(Figure C)



Dash Disassembly

Chevy Express Van/GMC Savanna 2008-up

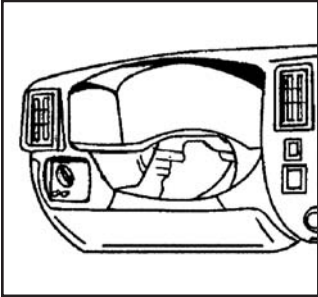

(Figure A)

1. Remove (2) 10 mm bolts from below knee bolster under steering column and remove panel.
2. Remove (2) 10 mm bolts from panel below passenger dash airbag and remove panel.
3. Unsnap and remove radio and instrument cluster panel.

Note: To access radio it may not be necessary to completely remove radio and instrument cluster panel.

4. Remove (4) 9/32" bolts to remove radio.

Continue to kit assembly

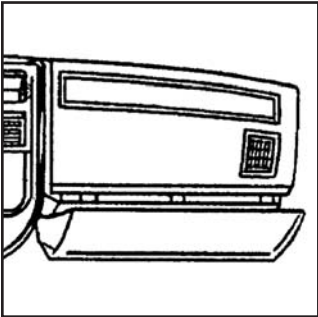

(Figure B)

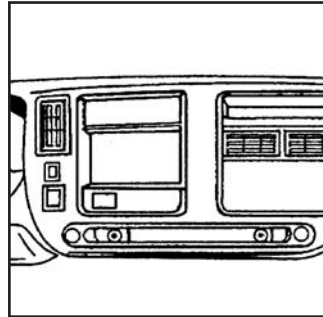

(Figure C)

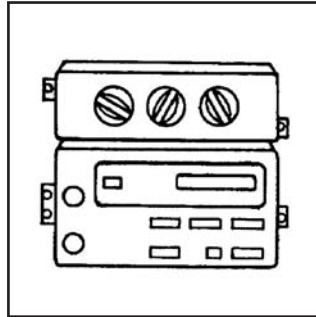

(Figure D)

Suzuki XL-7 2007-2009

1. Press in on sides of the shifter boot to release it from the shifter trim panel. (Figure A)
2. Lift the boot up to access the Allen screw securing the shifter knob to the shifter lever. Loosen the Allen screw and remove the shifter knob. (Figure B)
3. Remove (1) Torx screw from the shifter trim panel

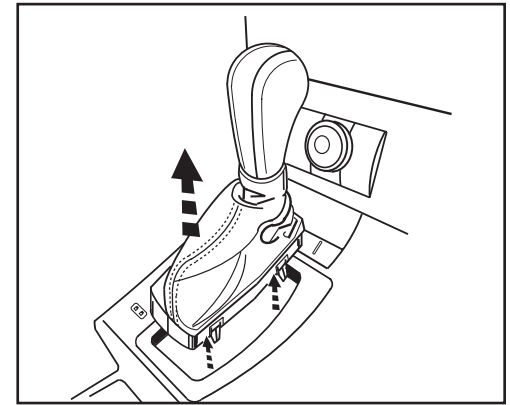

(Figure A)



Dash Disassembly

Suzuki XL-7 2007-2009

(Figure C), then using the panel removal tool unsnap the shifter trim panel. Unplug and remove the panel. (Figure D)

- Using a panel removal tool unsnap the radio trim panel. Unplug and remove the panel. (Figure E)
- Remove (4) 9/32" screws securing the radio. Unplug and remove the radio.

Continue to kit assembly

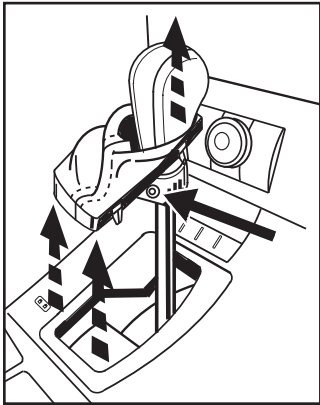

(Figure B)

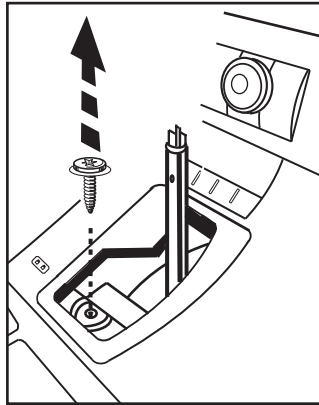

(Figure C)

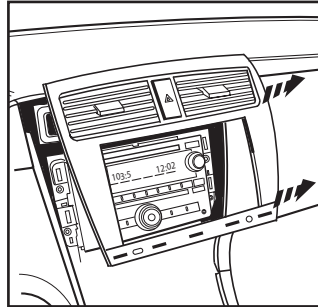

(Figure E)

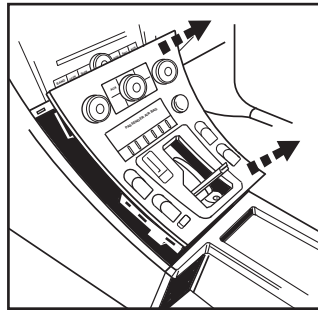

(Figure D)

Chevy Equinox/Pontiac Torrent 2007-2009

- Unsnap panel below power window switch and remove. (Figure A)

Note: This allows you to unplug the window switch easier.

- Unsnap and remove entire panel surrounding radio and shifter. (Figure B, next page)
- Remove (4) 9/32" screws securing radio. Unplug and remove the radio. (Figure C, next page)

Continue to kit assembly

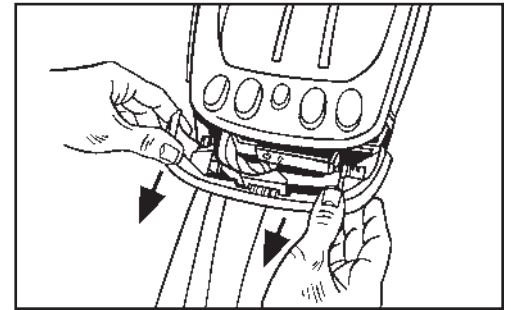

(Figure A)



Dash Disassembly

Chevy Equinox/Pontiac Torrent 2007-2009

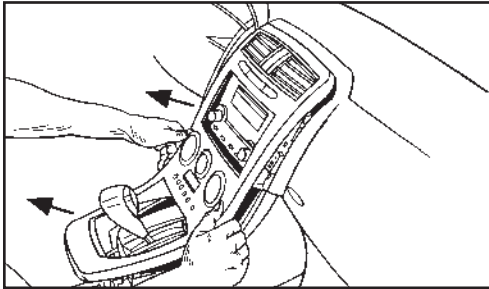

(Figure B)

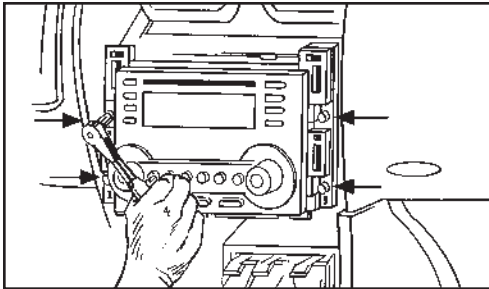

(Figure C)

Buick Enclave 2008-2012/GMC Acadia 2007-2012, Saturn Outlook 2007-2010, Chevy Traverse 2009-up

1. Unclip the radio trim panel including the climate controls.
2. Unplug the climate controls and remove the panel.
3. Remove (4) 9/32" screws securing the radio. Unplug and remove the radio.

Continue to kit assembly

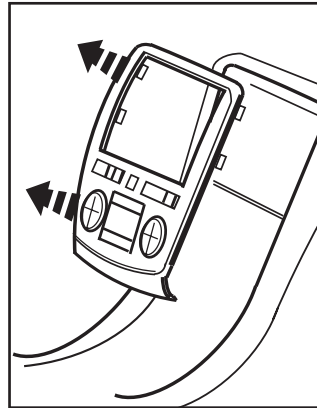

Buick Enclave/Chevy Traverse

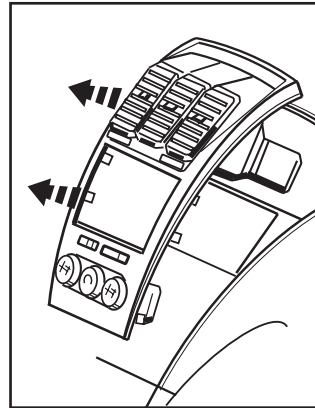

GMC Acadia

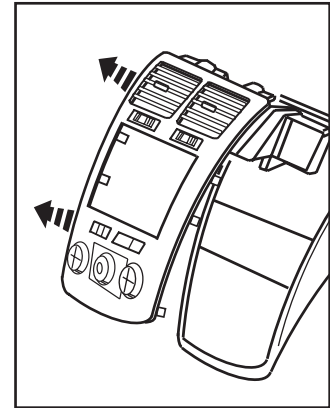

Saturn Outlook



Dash Disassembly

Hummer H2 2008-2009

1. Unclip the radio trim panel including the A/C vents.
2. Unplug any harnesses connected to the panel and remove the panel. (Figure A)
3. Remove (4) 9/32" screws securing the climate controls.
4. Unplug and remove the climate controls.
5. Remove (4) 9/32" screws securing the radio. Unplug and remove the radio.

Continue to kit assembly

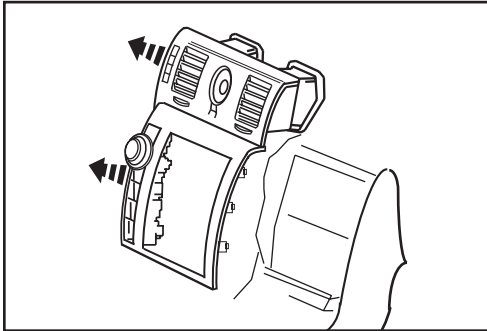

(Figure A)

Saturn Vue 2008-2010/Chevrolet Captiva 2012

1. Unclip and remove the trim panel on top of the radio trim panel. (Figure A)
2. Remove (2) Phillips screws exposed under panel previously removed. (Figure B)
3. Unclip and remove the radio trim panel including the A/C vents. (Figure B)
4. Unclip and remove the trim panel surrounding the shifter including the climate controls. (Figure C)
5. Remove (4) 9/32" screws securing the radio. Unplug and remove the radio.

Continue to kit assembly

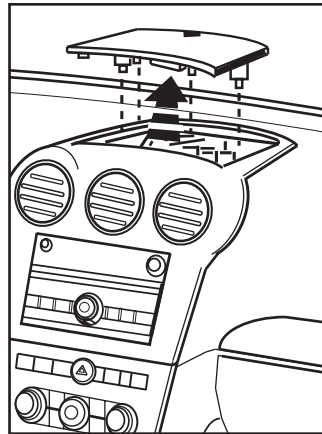

(Figure A)

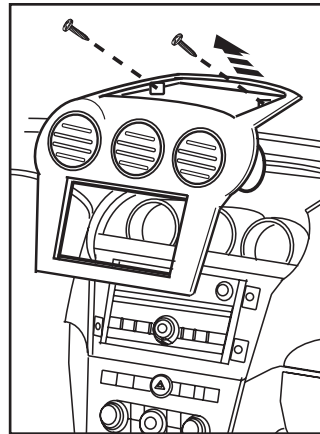

(Figure B)

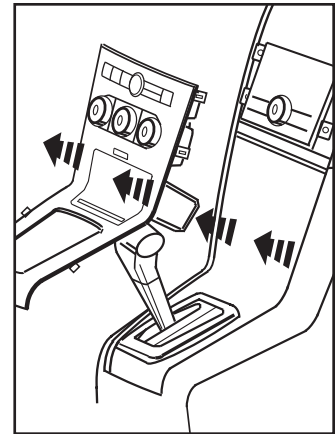

(Figure C)



Kit Assembly 95-3305

Double DIN radio provision

1. Slide the double DIN bracket into the trim plate aligning the holes in the trim plate to the clips on the bracket. (Figure B)
2. Slide the double DIN radio unit into the trim plate bracket assembly and secure the unit to the kit using the screws supplied with the head unit. (Figure C)
3. Locate the factory wiring harness in the dash. Metra recommends using the proper mating adapter from Metra or AXCESS. Re-connect the negative battery terminal and test the unit for proper operation.
4. Reassemble dash in reverse order of disassembly.

Note XL-7 ONLY: Trim top corners of radio housing. (Figure A)

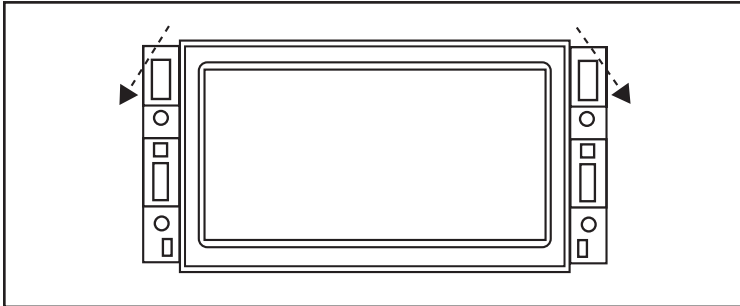

(Figure A)

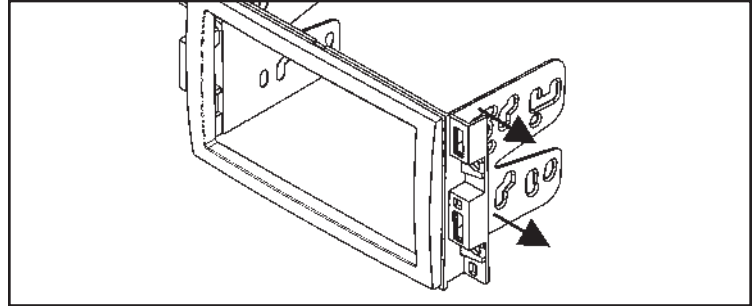

(Figure B)

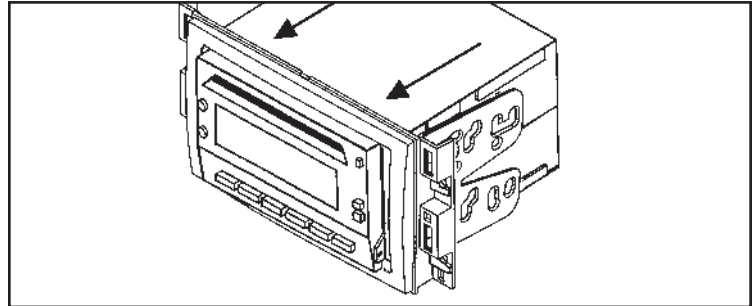

(Figure C)



Kit Assembly 95-3305

Stacked ISO radio provision

1. Slide the double DIN bracket into the trim plate aligning the holes in the trim plate to the clips on the bracket. (Figure B)
2. Slide the stacked ISO DIN units into the trim plate bracket assembly and secure the units to the kit using the screws supplied with the head unit. (Figure C)
3. Locate the factory wiring harness in the dash. Metra recommends using the proper mating adapter from Metra or AXCESS. Re-connect the negative battery terminal and test the unit for proper operation.
4. Reassemble dash in reverse order of disassembly.

Note XL-7 ONLY: Trim top corners of radio housing. (Figure A)

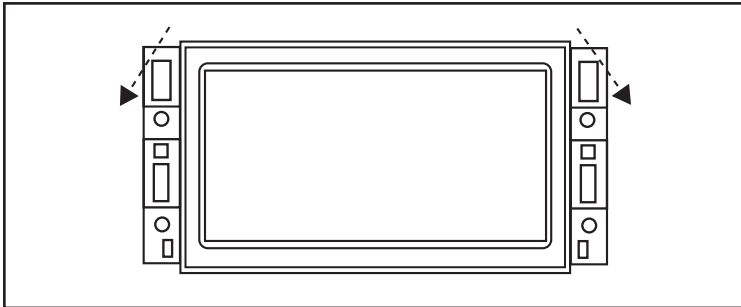

(Figure A)

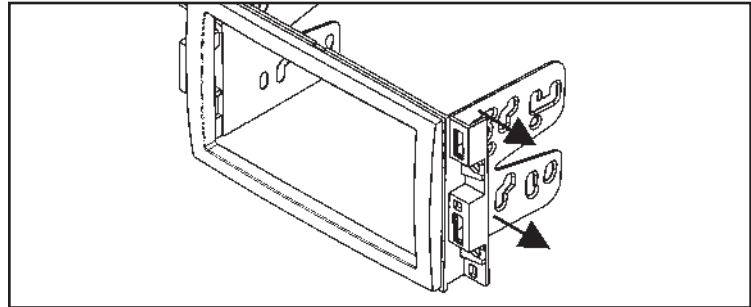

(Figure B)

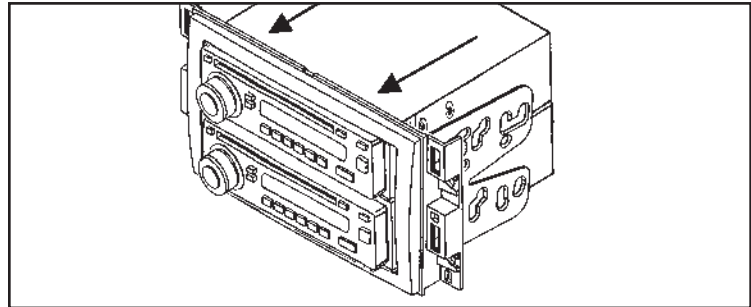

(Figure C)



Kit Assembly 99-3305

DIN radio provision with pocket

1. Slide the DIN cage into the radio housing and secure by bending the metal locking tabs down. (Figure B)

Note XL-7 ONLY: Trim top corners of radio housing. (Figure A)

2. Slide the aftermarket radio into the cage and secure. (Figure C)
3. Locate the factory wiring harness in the dash. Metra recommends using the proper mating adapter from Metra or AXXESS. Re-connect the negative battery terminal and test the unit for proper operation.
4. Reassemble dash in reverse order of disassembly.

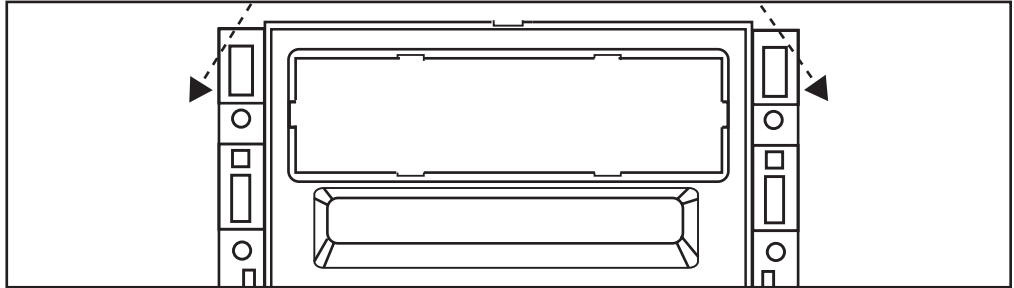

(Figure A)

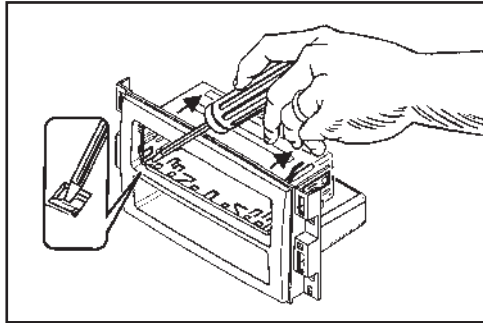

(Figure B)

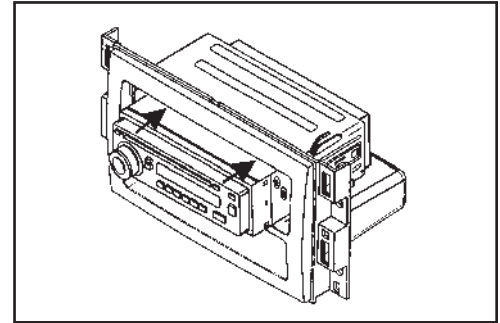

(Figure C)



Kit Assembly 99-3305

ISO radio provision with pocket

1. Mount the ISO brackets to the radio with the screws supplied with the unit. (Figure B)
Note XL-7 ONLY: Trim top corners of radio housing. (Figure A)
2. Slide the radio into the radio opening until the side clips engage. (Figure C)
3. Snap the trim plate into the radio housing. (Figure C)
4. Locate the factory wiring harness in the dash. Metra recommends using the proper mating adapter from Metra or AXCESS. Re-connect the negative battery terminal and test the unit for proper operation.
5. Reassemble dash in reverse order of disassembly.

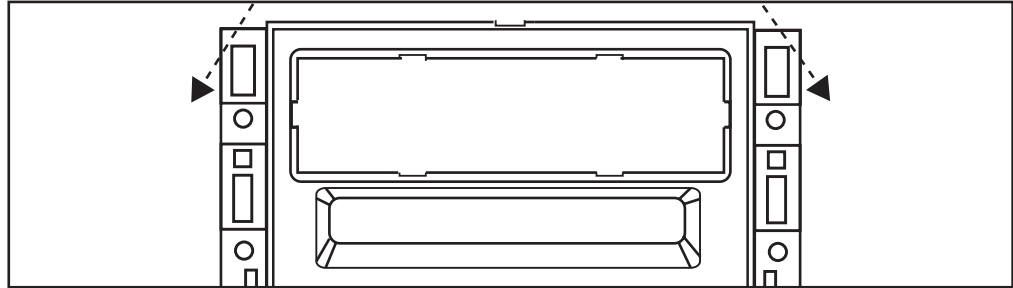

(Figure A)

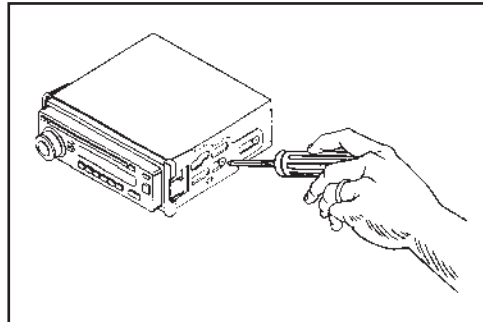

(Figure B)

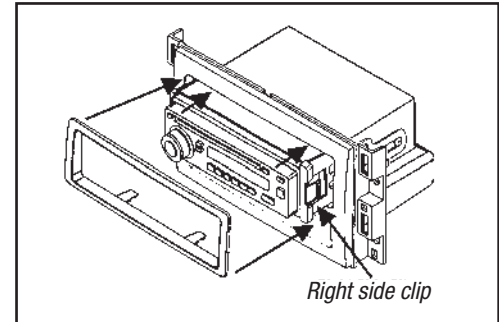

(Figure C)



INSTALLATION INSTRUCTIONS FOR PARTS 95-3305 or 99-3305



REV. 9/19/2013 INST-3305



KNOWLEDGE IS POWER

Enhance your installation and fabrication skills by enrolling in the most recognized and respected mobile electronics school in our industry. Log onto www.installerinstitute.com or call 800-354-6782 for more information and take steps toward a better tomorrow.

**Metra recommends MECP
certified technicians**

METRA. The World's best kits.™

1-800-221-0932

metraonline.com

© COPYRIGHT 2004-2011 METRA ELECTRONICS CORPORATION



INSTRUCCIONES DE INSTALACIÓN PARA LA PIEZA 95-3305 o 99-3305

APLICACIONES

Lista de aplicaciones dentro

GM multi-kit 2006 y mas 95-3305 o 99-3305

CARACTERÍSTICAS DEL KIT

95-3305:

- Provisión de radio doble DIN
- Provisión de radio ISO vertical

99-3305:

- Provisión de radio DIN con bolsillo
- Provisión de radio ISO vertical con bolsillo



COMPONENTES DEL KIT

95-3305: • A1) Placa de terminación DIN doble • B1) Soportes DIN dobles

99-3305: • A2) Alojamiento del radio • B2) Soportes ISO • C2) Placa de moldura

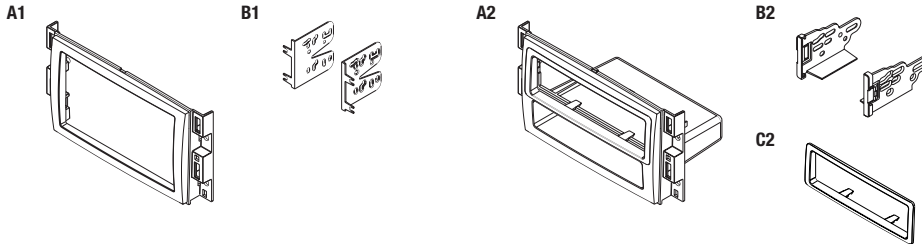

CABLEADO Y CONEXIONES DE ANTENA

Arnés del cableado: (se venden por separado)

- GMOS-LAN-01 - GM interfaz 29 LAN 2006 y mas
- GMOS-LAN-02 - GM interfaz 29 LAN amplificada 2006 y mas
- GMOS-LAN-07 - GM interfaz LAN amplificada 2012 y mas (equipado con NAV fábrica)

Adaptador de antena:

- 40-CR10 - Adaptador de antena Chrysler/GM 2002 y mas

HERRAMIENTAS REQUERIDAS

- Destornillador de hoja plana pequeño
- Herramienta para retirar paneles
- Destornillador Phillips
- Juego de soportes
- Destornillador Torx
- Llave Allen

PRECAUCIÓN: Metra recomienda desconectar el terminal negativo de la batería antes de comenzar cualquier instalación. Todos los accesorios, interruptores y, especialmente, las luces indicadoras de airbag deben estar enchufados antes de volver a conectar la batería a comenzar el ciclo de ignición.

NOTA: Remítase a las instrucciones incluidas con el radio de postventa.



95-3305 o 99-3305

Applications

Buick

Enclave	2008-2012
Lucerne	2006-2011

Chevrolet

Avalanche	2007 y mas
Equinox	2007-2009
Express Van	2008 y mas
Impala	2006 y mas
Monte Carlo	2006-2007
Silverado**	2007 y mas
Suburban	2007 y mas
Tahoe	2007 y mas
Traverse	2009 y mas
Captiva Sport.....	2012

GMC

Acadia	2007-2012
Savanna	2008 y mas
Sierra**	2007 y mas
Yukon XL Denali.....	2007 y mas
Yukon/XL	2007 y mas

Hummer

H2	2008-2009
----------	-----------

Pontiac

Torrent	2007-2009
---------------	-----------

Saturn

Outlook	2007-2010
Vue	2008-2010

Suzuki

XL-7	2007-2009
------------	-----------

***No incluye los modelos clásicos*

Indice

Desmontaje del tablero

- Buick Enclave 2008-2012	6
- Buick Lucerne 2006-2011.....	3
- Chevrolet Avalanche 2007 y mas.....	3

Indice

- Chevrolet Captiva Sport 2012.....	7
- Chevrolet Equinox 2007-2009.....	5-6
- Chevrolet Express Van (<i>full size</i>) 2008 y mas.....	4
- Chevrolet Impala 2006 y mas.....	3
- Chevrolet Monte Carlo 2006-2007.....	3
- Chevrolet Silverado Pickup (<i>No incluye los modelos clásicos</i>) 2007 y mas.....	3
- Chevrolet Suburban 2007 y mas.....	3
- Chevrolet Tahoe 2007 y mas	3
- Chevrolet Traverse 2009 y mas	6
- GMC Acadia 2007-2012	6
- GMC Savanna Van (<i>full size</i>) 2008-2010.....	4
- GMC Sierra (<i>No incluye los modelos clásicos</i>) 2007 y mas	3
- GMC Yukon/Yukon XL/Yukon XL Denali 2007 y mas	3
- Hummer H2 2008-2009	7
- Pontiac Torrent 2007-2009.....	5-6
- Saturn Outlook 2007-2010.....	6
- Saturn Vue 2008-2010	7
- Suzuki XL-7 2007-2009	4-5

Ensamble del kit

- Provisión de radio doble DIN.....	8
- Provisión de radio ISO vertical	9
- Provisión de radio DIN con bolsillo.....	10
- Provisión de radio ISO vertical con bolsillo.....	11



Desmontaje del tablero

Buick Lucerne 2006-2011, Chevy Impala 2006 y mas, Monte Carlo 2006-2007

1. Desenganche y retire el panel de terminación que rodea el control del radio y del aire acondicionado. (Figura A)
2. Retire (6) tornillos de 9/32" in para extraer el control del radio y del aire acondicionado del subtablero. (Figura B)

Continuará al ensamble del kit



(Figura A)

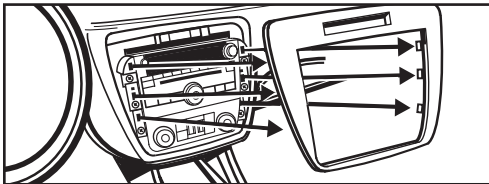

(Figura B)

Chevy Avalanche/Tahoe/Suburban/Silverado (No incluye los modelos clásicos) 2007 y mas, GMC Yukon/Sierra (No incluye los modelos clásicos) 2007 y mas

1. Desenganche y retire el panel de terminación del radio. (Figura A)
2. Retire (2) tornillos de 8 mm que sujetan el panel de interruptores debajo de los controles de clima. Desenchufe y retire el panel de interruptores. (Figura B)
3. Retire (2) tornillos de 8 mm que sujetan los controles de clima. Desenchufe y retire los controles de clima. (Figura B)
4. Retire (4) tornillos de 9/32" in que sujetan el radio. Desenchufe y retire el radio. (Figura C)

Continuará al ensamble del kit

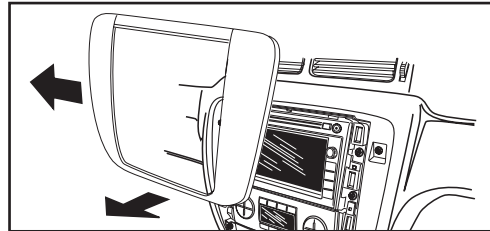

(Figura A)

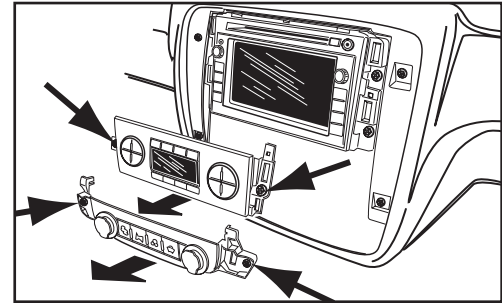

(Figura B)

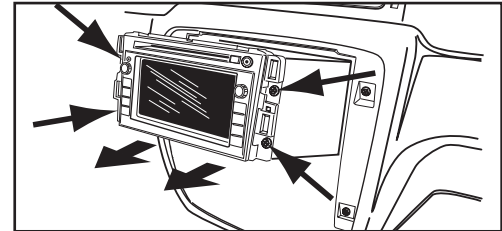

(Figura C)



Desmontaje del tablero

Chevy Express Van/GMC Savanna 2008 y mas

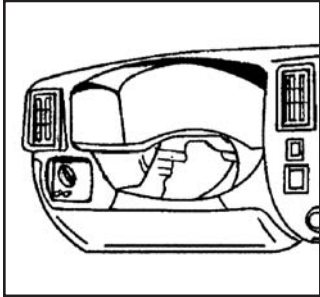

(Figura A)

1. Retire (2) pernos de 10 mm de la parte de abajo del amortiguador para las rodillas que se encuentra debajo de la columna de la dirección y retire el panel. (Figura A)
2. Retire (2) pernos de 10 mm del panel que se encuentra debajo del airbag del tablero del pasajero y retire el panel. (Figura B)
3. Quite a presión y retire el panel del radio y del grupo de instrumentos. (Figura C)

Nota: Es posible que no sea necesario retirar completamente el panel del radio y del grupo de instrumentos para tener acceso al radio.

4. Retire (4) pernos de 9/32" in para retirar el radio. (Figura D)

Continuará al ensamble del kit

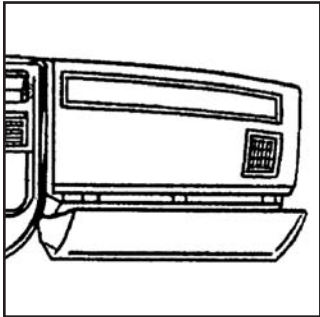

(Figura B)

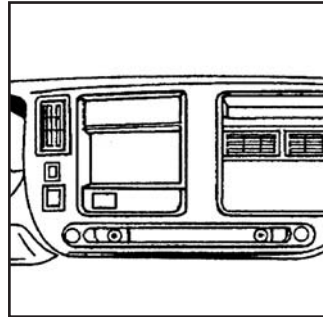

(Figura C)

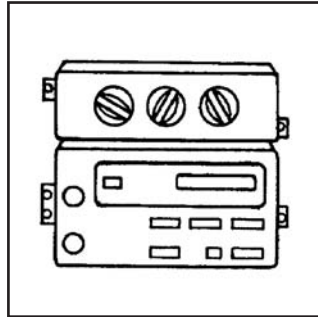

(Figura D)

Suzuki XL-7 2007-2009

1. Presione los lados de la cubierta de protección de la palanca de velocidades para liberarla del panel de terminación de la palanca de velocidades. (Figura A)
2. Levante la cubierta de protección para poder acceder al tornillo Allen, que sujeta la perilla de la palanca de velocidades a la palanca de velocidades. Afloje el tornillo Allen y retire la perilla de la palanca de velocidades. (Figura B)
3. Retire (1) tornillo Torx del panel de terminación

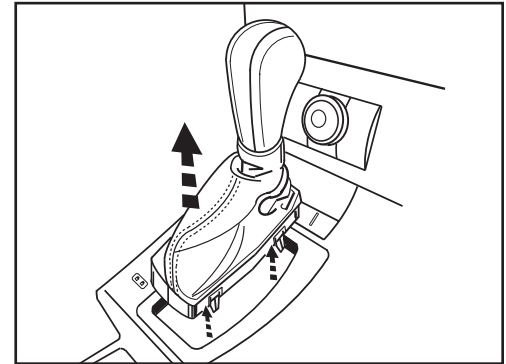

(Figura A)



Desmontaje del tablero

Suzuki XL-7 2007-2009

de la palanca de velocidades (Figura C), y luego use una herramienta para retirar paneles para quitar a presión el panel de terminación de la palanca de velocidades. Desenchufe y retire el panel. (Figura D)

4. Con una herramienta para retirar paneles, quite a presión el panel de terminación del radio. Desenchufe y retire el panel. (Figura E)
5. Retire (4) tornillos de 9/32" in que sujetan el radio. Desenchufe y retire el radio.

Continuará al ensamble del kit

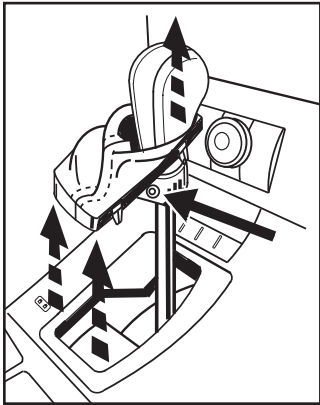

(Figura B)

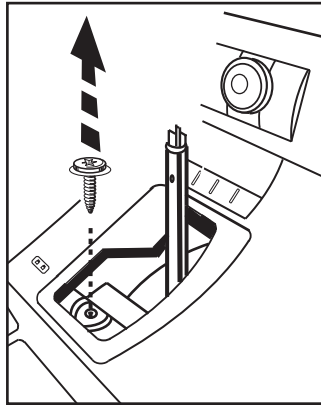

(Figura C)

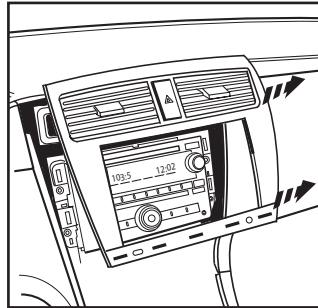

(Figura E)

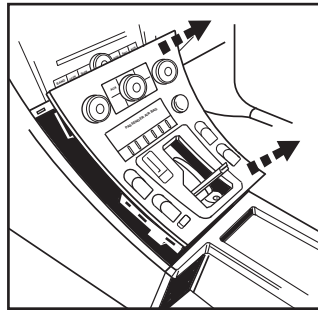

(Figura D)

Chevy Equinox/Pontiac Torrent 2007-2009

1. Quite a presión el panel que se encuentra debajo del interruptor del alzacristales y retírelo. (Figura A)

Nota: Esto le permite desenchufar el interruptor de las ventanas con mayor facilidad.

2. Quite a presión y retire el panel completo que rodea el radio y la palanca de velocidades. (Figura B, página siguiente)
3. Retire (4) tornillos de 9/32" in que sujetan el radio. Desenchufe y retire el radio. (Figura C, página siguiente)

Continuará al ensamble del kit

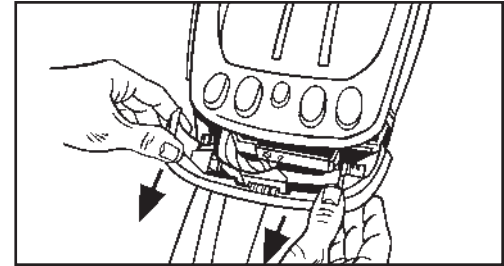

(Figura A)



Desmontaje del tablero

Chevy Equinox/Pontiac Torrent 2007-2009

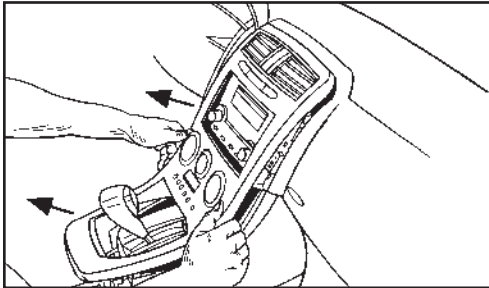

(Figura B)

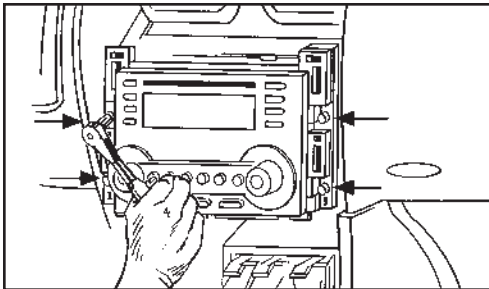

(Figura C)

Buick Enclave 2008-2012/GMC Acadia 2007-2012, Saturn Outlook 2007-2010, Chevy Traverse 2009 y mas

1. Desenganche el panel de terminación del radio, incluidos los controles de clima.
2. Desenchufe los controles de clima y retire el panel (vea los dibujos).
3. Retire (4) tornillos de 9/32" in que sujetan el radio. Desenchufe y retire el radio.

Continuará al ensamble del kit

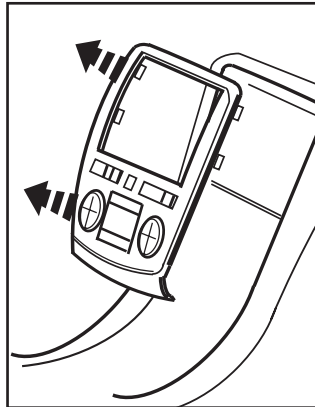

Buick Enclave/Chevy Traverse

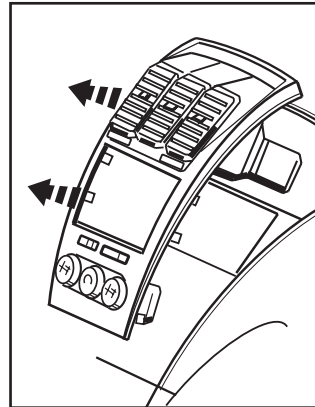

GMC Acadia

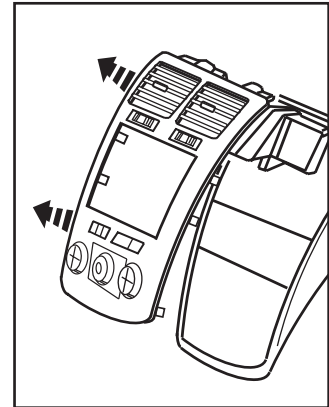

Saturn Outlook



Desmontaje del tablero

Hummer H2 2008-2009

1. Desenganche el panel de terminación del radio, incluidas las rejillas de ventilación del aire acondicionado. (Figura A)
2. Desenchufe cualquier arnés que esté conectado al panel y retire el panel. (Figura A)
3. Retire (4) tornillos de 9/32" in que sujetan los controles de clima. (Figura B)
4. Desenchufe y retire los controles de clima. (Figura B)
5. Retire (4) tornillos de 9/32" in que sujetan el radio. Desenchufe y retire el radio. (Figura C)

Continuará al ensamble del kit

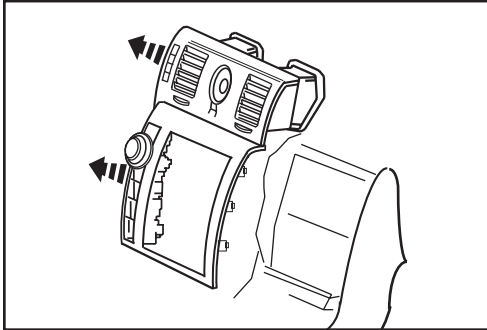

(Figura A)

Saturn Vue 2008-2010/Chevrolet Captiva 2012

1. Desenganche y retire el panel de terminación que está en la parte superior del panel de terminación del radio. (Figura A)
2. Retire (2) tornillos Phillips expuestos que se encuentran debajo del panel que se retiró. (Figura B)
3. Desenganche y retire el panel de terminación del radio, incluidas las rejillas de ventilación del

aire acondicionado. (Figura B)

4. Desenganche y retire el panel de terminación que rodea la palanca de velocidades, incluidos los controles de clima. (Figura C)
5. Retire (4) tornillos de 9/32" in que sujetan el radio. Desenchufe y retire el radio.

Continuará al ensamble del kit

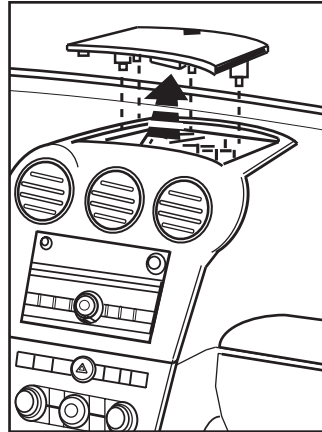

(Figura A)

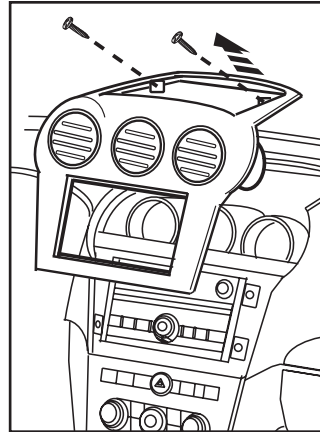

(Figura B)

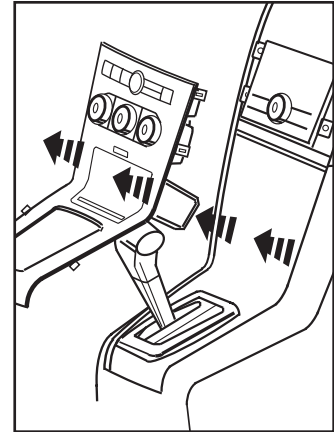

(Figura C)



Ensamble del kit 95-3305

Provisión de radio doble DIN

1. Deslice el soporte doble DIN en la placa de montaje de la alineación de los agujeros en la placa de montaje de los clips en el soporte. (Figura B)

Nota XL-7 solamente: Recorte las esquinas superiores de la carcasa de la radio. (Figura A)

2. Deslice la unidad de doble DIN radio en el conjunto de la placa soporte del asiento y fije la unidad al equipo con los tornillos suministrados con

la unidad principal. (Figura C)

3. Ubique el arnés del cableado de fábrica en el tablero. Metra recomienda usar el adaptador de acoplamiento adecuado de Metra o AXCESS. Vuelva a conectar el terminal negativo de la batería y pruebe la unidad para verificar que funcione correctamente.
4. Vuelva a montar el tablero en forma inversa al desmontaje.

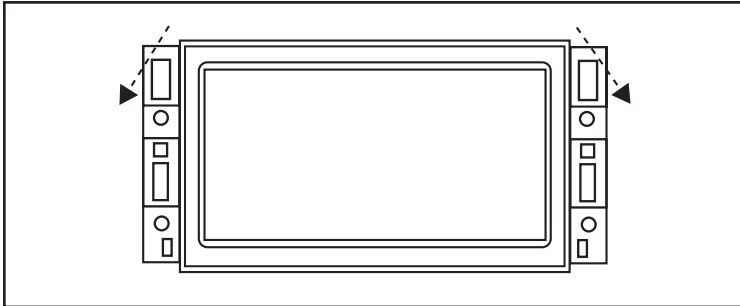

(Figura A)

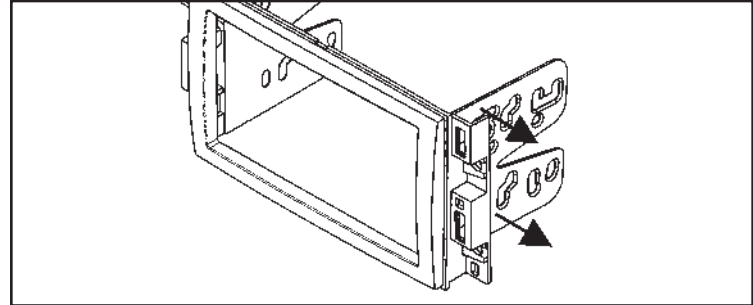

(Figura B)

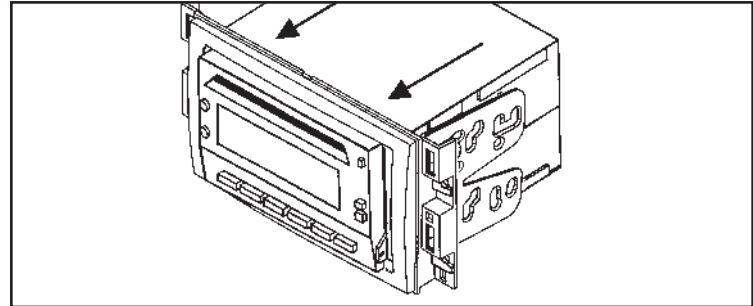

(Figura C)



Ensamble del kit 95-3305

Provisión de radio ISO vertical

1. Deslice el soporte de doble DIN en la placa de montaje de la alineación de los orificios de la placa de montaje de los clips en el soporte. (Figura B)

Nota XL-7 solamente: Recorte las esquinas superiores de la carcasa de la radio. (Figura A)

2. Deslice las unidades apiladas ISO DIN en el conjunto de la placa soporte del asiento y fijar las unidades al equipo con los tornillos

3. Ubique el arnés del cableado de fábrica en el tablero. Metra recomienda usar el adaptador de acoplamiento adecuado de Metra o AXCESS. Vuelva a conectar el terminal negativo de la batería y pruebe la unidad para verificar que funcione correctamente.
4. Vuelva a montar el tablero en forma inversa al desmontaje.

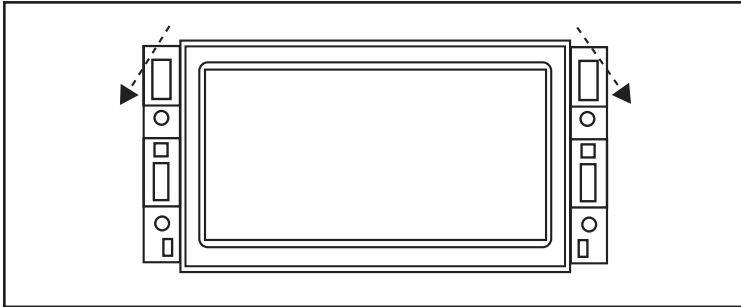

(Figura A)

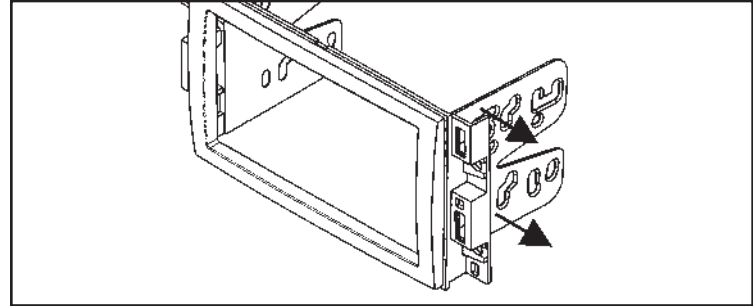

(Figura B)

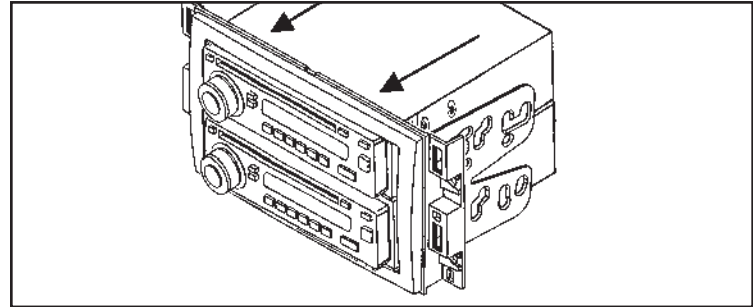

(Figura C)



Ensamble del kit 99-3305

Provisión de radio DIN con bolsillo

1. Deslice la jaula DIN en la caja de la radio y asegurar doblando las lengüetas de fijación de metal hacia abajo. (Figura B)

Nota XL-7 solamente: Recorte las esquinas superiores de la carcasa de la radio. (Figura A)

2. Deslice el radio no original en la jaula y seguro. (Figura C)

3. Ubique el arnés del cableado de fábrica en el tablero. Metra recomienda usar el adaptador de acoplamiento adecuado de Metra o AXCESS. Vuelva a conectar el terminal negativo de la batería y pruebe la unidad para verificar que funcione correctamente.

4. Vuelva a montar el tablero en forma inversa al desmontaje.

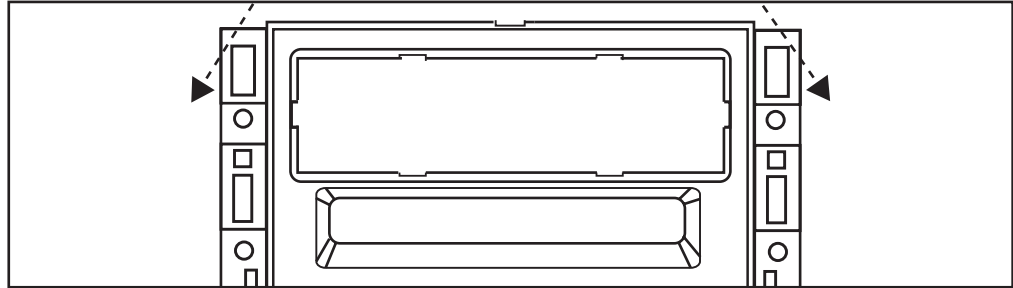

(Figura A)

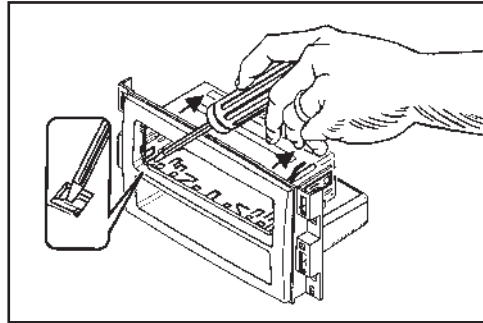

(Figura B)

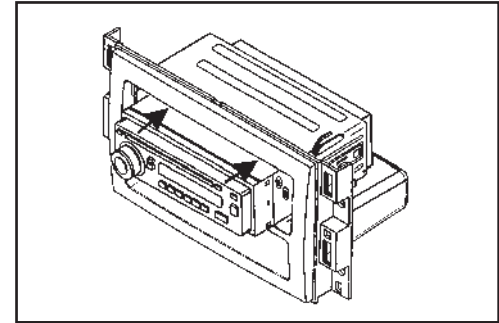

(Figura C)



Ensamble del kit 99-3305

Provisión de radio ISO vertical con bolsillo

1. Montar los soportes de la ISO a la radio con los tornillos suministrados con la unidad. (Figura B)

Nota XL-7 solamente: Recorte las esquinas superiores de la carcasa de la radio. (Figura A)

2. Deslice la radio en la apertura de la radio hasta que los clips secundarios participen. (Figura C)
3. Coloque la placa de montaje en la carcasa de la radio. (Figura C)
4. Ubique el arnés del cableado de fábrica en el tablero. Metra recomienda usar el adaptador de acoplamiento adecuado de Metra o AXCESS. Vuelva a conectar el terminal negativo de la batería y pruebe la unidad para verificar que funcione correctamente.
5. Vuelva a montar el tablero en forma inversa al desmontaje.

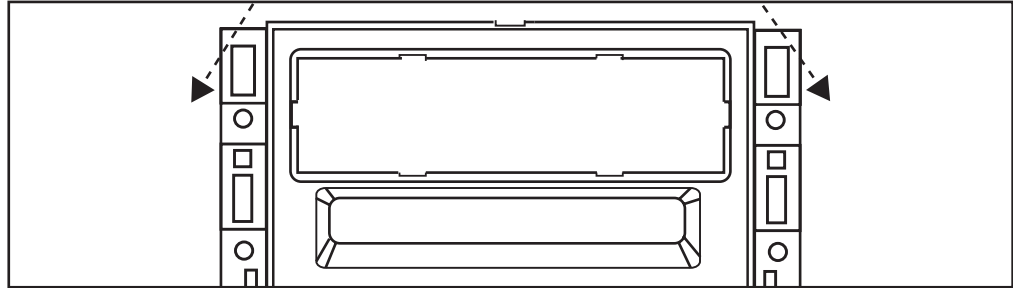

(Figura A)

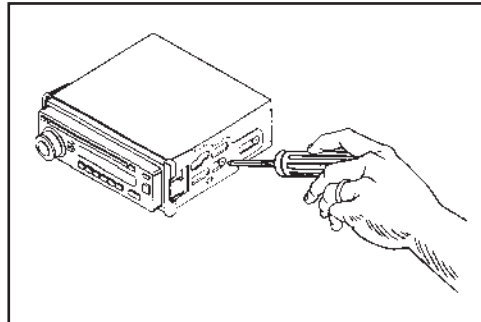

(Figura B)

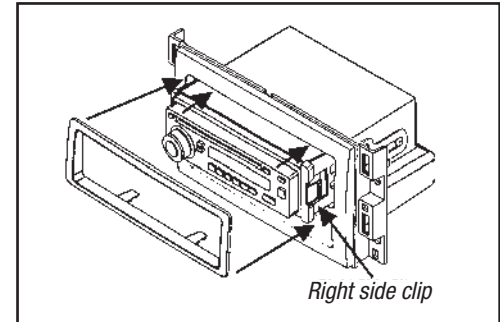

(Figura C)



INSTRUCCIONES DE INSTALACIÓN PARA LA PIEZA 95-3305 o 99-3305



REV.9/19/2013 INST-3305



EL CONOCIMIENTO ES PODER
Mejore sus habilidades de instalación y fabricación inscribiéndose en la escuela de dispositivos electrónicos móviles más reconocida y respetada de nuestra industria. Regístrese en www.installerinstitute.com o llame al 800-354-6782 para obtener más información y avance hacia un futuro mejor.



Metra recomienda técnicos con certificación del Programa de Certificación en Electrónica Móvil (Mobile Electronics Certification Program, MECP).