



INSTALLATION INSTRUCTIONS FOR PART 99-7505

APPLICATIONS

MAZDA

2001-2002 626 / 1998-2005 Miata

1995-2002 Millennia

2001-2004 Protege / 2001-2004 Protege 5

2001-2006 Tribute / 1996-1999 MPV

99-7505



KIT FEATURES

- DIN Head Unit Provisions with Pocket
- Double DIN Head Unit Provisions
- Stacked ISO DIN Head Unit Provisions

KIT COMPONENTS

A) Radio Housing (Single DIN w/ Pocket) | B) Double DIN Trim Plate | C) Double DIN Brackets | D) Rear Support

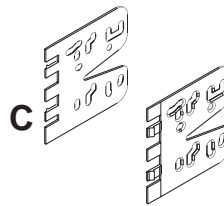
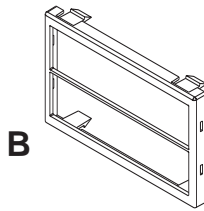
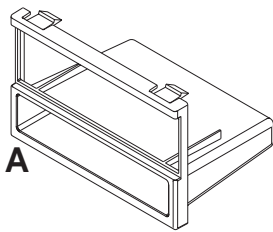

TOOLS REQUIRED:

Ford Radio Removal Keys | Cutting Tool | Small Flathead Screwdriver | Phillips Screwdriver
(2 Sets) 86-5618

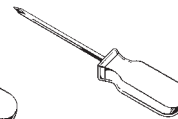
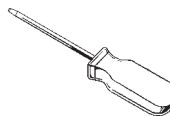
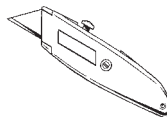
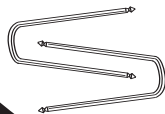

1-800-221-0932



www.metraonline.com

© COPYRIGHT 2004-07 METRA ELECTRONICS CORPORATION



99-7505

TABLE OF CONTENTS

<i>Dash Disassembly</i>	1
<i><u>Kit Assembly</u></i>	
<i>DIN Head Unit Provisions</i>	2
<i>Double DIN Head Unit Provisions</i>	3
<i>Stacked ISO DIN Head Unit Provisions</i>	4
<i>Final Assembly</i>	5

ALL VEHICLES

- 1 Disconnect the negative battery terminal to prevent an accidental short circuit.
- 2 Using small flathead screwdriver, carefully remove the trim covers from both sides of the radio. (Figure A)
- 3 Insert 2 sets of Ford radio removal keys into the sides of the radio until they snap in. (Figure B)
- 4 Gripping both sets of removal keys, pull keys outward away from the radio then slide radio out. (Figure C)

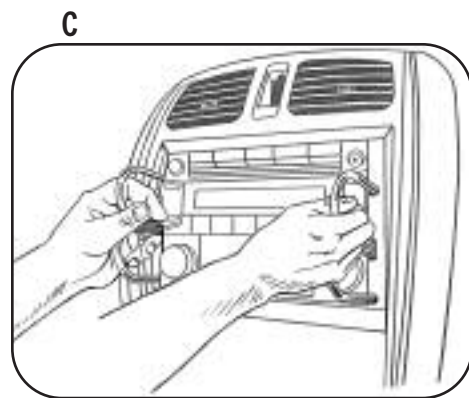
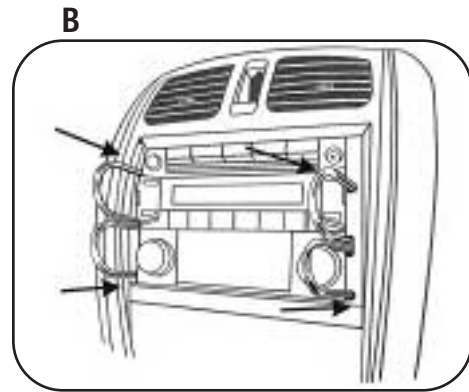
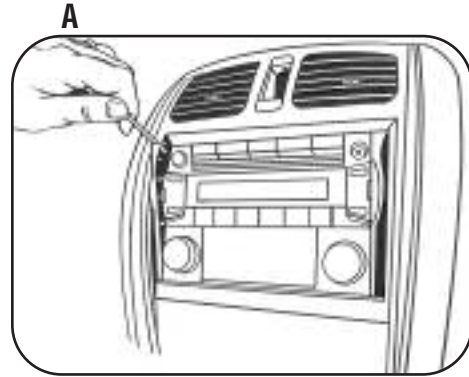

DASH DISASSEMBLY

DIN HEAD UNIT PROVISIONS

- 1 Slide the DIN cage into the Radio Housing and secure by bending the metal locking tabs down. (Figure A)
- 2 Slide the aftermarket head unit into the cage and secure. (Figure B)
- 3 Using the hardware that came with the aftermarket radio secure the rear support to the back of the aftermarket radio. (Figure C)

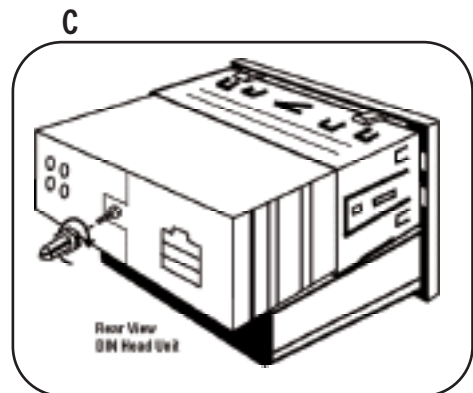
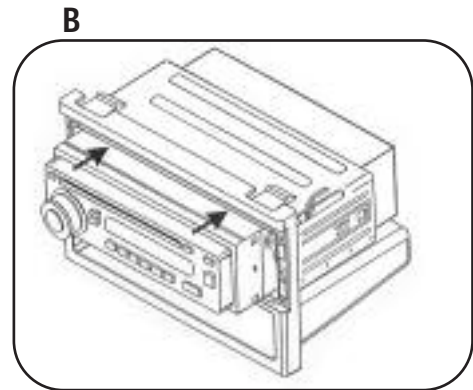
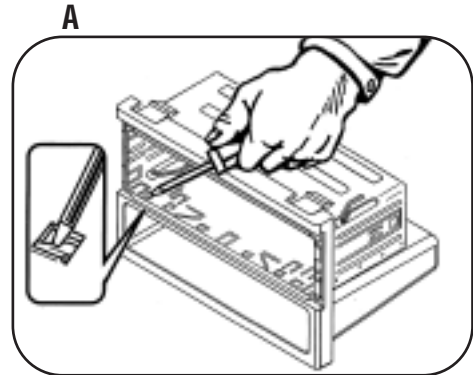

DOUBLE DIN HEAD UNIT PROVISIONS

- 1 Using a cutting tool remove the center bar from the Double DIN trim plate. (Figure A)
- 2 Slide the appropriate side bracket into the Double DIN trim plate aligning the holes in the trim plate to the clips on the bracket. (Figure B)
- 3 Slide the DDIN radio unit into the trim plate bracket assembly and secure the unit to the kit using the screws supplied with the head unit. (Figure C)
- 4 Using the hardware that came with the aftermarket radio secure the rear support to the back of the aftermarket radio. (Figure D)

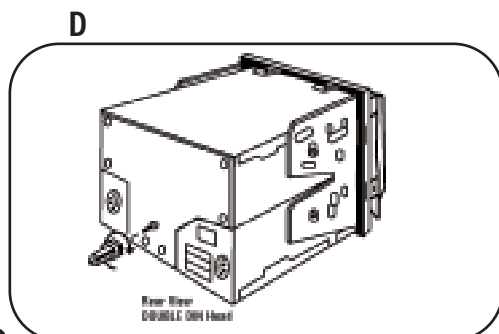
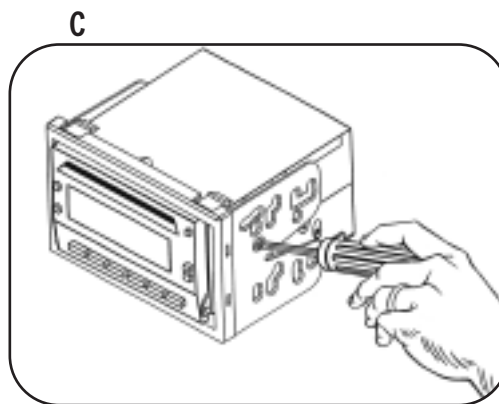
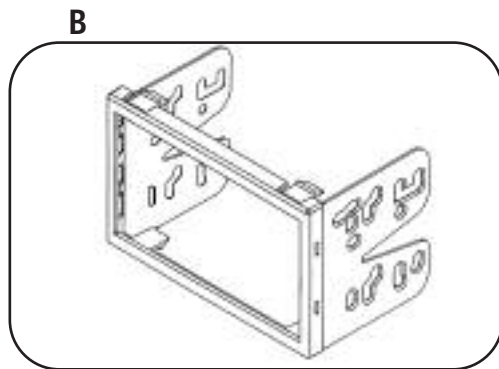
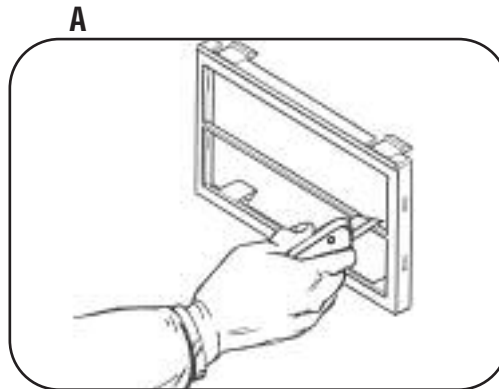

KIT ASSEMBLY

STACKED ISO DIN HEAD UNIT PROVISIONS

- 1 Slide the appropriate side bracket into the Double DIN trim plate aligning the holes in the trim plate to the clips on the bracket.
- 2 Slide the stacked ISO DIN units into the trim plate bracket assembly and secure the units to the kit using the screws supplied with the head units. (Figure A)
- 3 Using the hardware that came with the aftermarket radio secure the rear support to the back of the aftermarket radio. (Figure B)

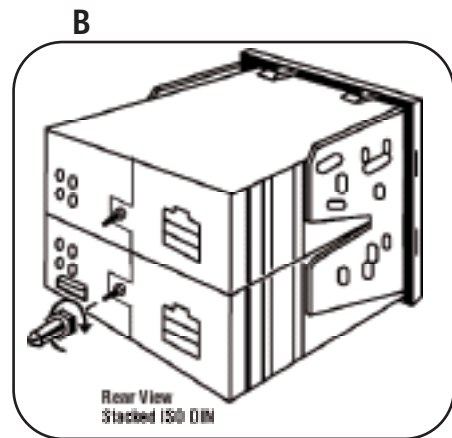
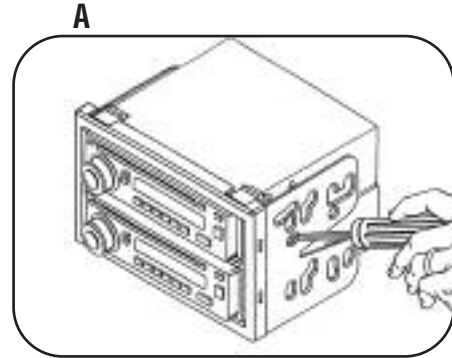

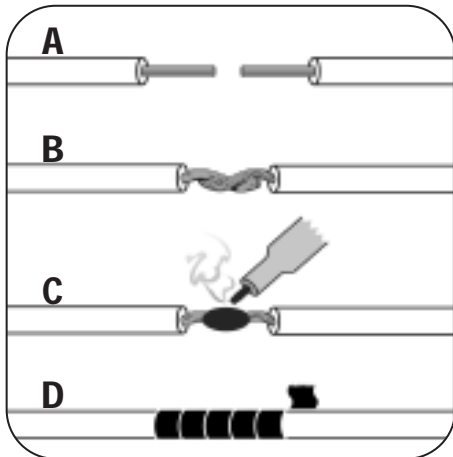

- A) Strip wire ends back 1/2"**
- B) Twist ends together**
- C) Solder**
- D) Tape**

FINAL ASSEMBLY

- 1** Locate the factory wiring harness in the dash. Metra recommends using the proper mating adapter and making the connections as shown. (Isolate and individually tape off the ends of any unused wires to prevent electrical short circuit)

- 2** Re-connect the negative battery terminal and test the unit for proper operation.

- 3** Reassemble radio and dash assemblies in reverse order of disassembly.

INST99-7505



1-800-221-0932



www.metraonline.com

Rev. 06-20-07

© COPYRIGHT 2004-07 METRA ELECTRONICS CORPORATION

INST99-7505