

# Intel<sup>®</sup> RAID Expander Card RES3FV288 Hardware User's Guide

---

Intel Order Number: H34798-003

## DISCLAIMER

INFORMATION IN THIS DOCUMENT IS PROVIDED IN CONNECTION WITH INTEL PRODUCTS. NO LICENSE, EXPRESS OR IMPLIED, BY ESTOPPEL OR OTHERWISE, TO ANY INTELLECTUAL PROPERTY RIGHTS IS GRANTED BY THIS DOCUMENT. EXCEPT AS PROVIDED IN INTEL'S TERMS AND CONDITIONS OF SALE FOR SUCH PRODUCTS, INTEL ASSUMES NO LIABILITY WHATSOEVER AND INTEL DISCLAIMS ANY EXPRESS OR IMPLIED WARRANTY, RELATING TO SALE AND/OR USE OF INTEL PRODUCTS INCLUDING LIABILITY OR WARRANTIES RELATING TO FITNESS FOR A PARTICULAR PURPOSE, MERCHANTABILITY, OR INFRINGEMENT OF ANY PATENT, COPYRIGHT OR OTHER INTELLECTUAL PROPERTY RIGHT.

A "Mission Critical Application" is any application in which failure of the Intel Product could result, directly or indirectly, in personal injury or death. SHOULD YOU PURCHASE OR USE INTEL'S PRODUCTS FOR ANY SUCH MISSION CRITICAL APPLICATION, YOU SHALL INDEMNIFY AND HOLD INTEL AND ITS SUBSIDIARIES, SUBCONTRACTORS AND AFFILIATES, AND THE DIRECTORS, OFFICERS, AND EMPLOYEES OF EACH, HARMLESS AGAINST ALL CLAIMS COSTS, DAMAGES, AND EXPENSES AND REASONABLE ATTORNEYS' FEES ARISING OUT OF, DIRECTLY OR INDIRECTLY, ANY CLAIM OF PRODUCT LIABILITY, PERSONAL INJURY, OR DEATH ARISING IN ANY WAY OUT OF SUCH MISSION CRITICAL APPLICATION, WHETHER OR NOT INTEL OR ITS SUBCONTRACTOR WAS NEGLIGENT IN THE DESIGN, MANUFACTURE, OR WARNING OF THE INTEL PRODUCT OR ANY OF ITS PARTS.

Intel may make changes to specifications and product descriptions at any time, without notice. Designers must not rely on the absence or characteristics of any features or instructions marked "reserved" or "undefined". Intel reserves these for future definition and shall have no responsibility whatsoever for conflicts or incompatibilities arising from future changes to them. The information here is subject to change without notice. Do not finalize a design with this information.

The products described in this document may contain design defects or errors known as errata which may cause the product to deviate from published specifications. Current characterized errata are available on request.

Copies of documents which have an order number and are referenced in this document, or other Intel literature, may be obtained by calling 1-800-548-4725, or go to:  
<http://www.intel.com/design/literature.htm>.

Intel warrants that this product will perform to its published specifications. However, all computer systems are inherently subject to unpredictable system behavior under various environmental and other conditions.

This product is not intended to be the sole source for any critical data and the user must maintain a verified backup. Failure to do so or to comply with other user notices in the product user guide and specification documents may result in loss of or access to data.

# Regulatory Compliance Statements

---

## Federal Communications Commission Radio Frequency Interference Statement

**Attention:** Changes or modifications to this unit not expressly approved by the party responsible for compliance could void the user's authority to operate the equipment.

This equipment has been tested and found to comply with the limits for a Class B digital device, pursuant to Part 15 of the FCC rules. These limits are designed to provide reasonable protection against harmful interference in a residential installation. This equipment generates, uses, and can radiate radio frequency energy, and if not installed and used in accordance with the instruction manual, may cause harmful interference to radio communications. However, there is no guarantee that interference will not occur in a particular installation. However, if this equipment does cause interference to radio or television equipment reception, which can be determined by turning the equipment off and on, the user is encouraged to try to correct the interference by one or more of the following measures:

- Reorient or relocate the receiving antenna.
- Increase the separation between equipment and receiver.
- Connect the equipment to an outlet on a circuit different from that to which the receiver is connected.
- Consult the dealer or an experienced radio/television technician for help.
- Use a shielded and properly grounded I/O cable and power cable to ensure compliance of this unit to the specified limits of the rules.

This device complies with part 15 of the FCC rules. Operation is subject to the following two conditions: (1) this device may not cause harmful interference and (2) this device must accept any interference received, including interference that may cause undesired operation.

## UL Compliance Statement



Intel® products are tested and listed by Underwriters Laboratories, Inc. to UL 60950-1 Second Edition and IEC-60950-1 Second Edition standards, file numbers E175975. These products are for use only with UL listed ITE.

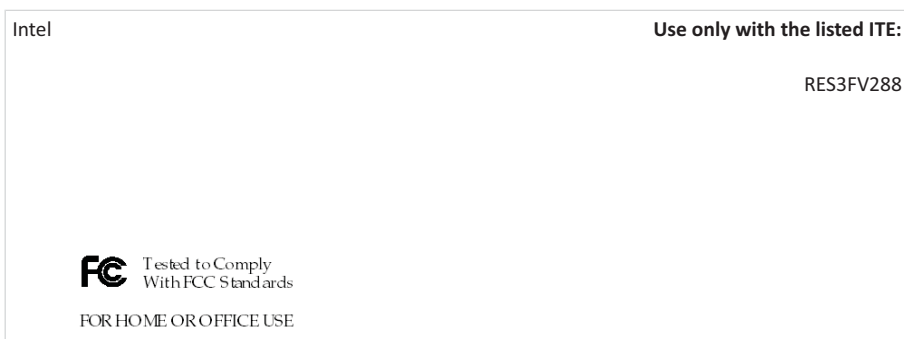

## Special International Committee on Radio Interference Compliance Statement (CISPR 22)

This product has been found to comply with the requirements of the Information Technology Equipment -- Radio Disturbance Characteristics -- Limits and Methods of Measurement (CISPR 22).

### European Union Compliance Statement



This Information Technology Equipment has been tested and found to comply with EMC Directive 89/336/EEC, as amended by 92/31/EEC and 93/68/EEC, in accordance with:

- EN55022 (1998+A1:2000+A2:2007) Emissions:
  - Class B ITE radiated and conducted emissions
- EN55024 (1998+A1:2001+A2:2010) Immunity:
  - EN61000-4-2 (2009) Electrostatic discharge:  $\pm 4$  kV contact,  $\pm 8$  kV air
  - EN61000-4-3 (2010) Radiated immunity: 3V/m
  - EN61000-4-4 (2004) Electrical fast transients/burst:  $\pm 1$  kV AC,  $\pm 0.5$  kV I/O
  - EN61000-4-5 (2006) Surges:  $\pm 1$  kV differential mode,  $\pm 2$  kV common mode
  - EN61000-4-6 (2009) Conducted immunity: 3 V
  - EN61000-4-11 (2004) Supply dips and variations: 30% and 100%
- EN50581 (2012) Technical Documentation:
  - For the assessment of electrical and electronic products with respect to the restriction of hazardous substances

In addition, all equipment requiring U.L. listing has been found to comply with EMC Directive 73/23/EEC as amended by 93/68/EEC in accordance with EN60950 with amendments A1, A2, A3, A4, A11.

### Australian/New Zealand Compliance Statement



This device has been tested and found to comply with the limits for a Class B digital device, pursuant to the Australian/New Zealand standard AS/NZS 3548 set out by the Spectrum Management Agency.

### Canadian Compliance Statement



This Class B digital apparatus meets all requirements of the Canadian Interference-Causing Equipment Regulations (ICES-003).

Cet appareil numérique de la classe B respecte toutes les exigences du Règlement sur le matériel brouilleur du Canada (ICES-003).

### Japanese Compliance (Voluntary Control Council Initiative)



This equipment complies to class B Information Technology equipment based on VCCI (Voluntary Control Council for Interface). This equipment is designed for home use but it may causes radio frequency interference problem if used too near to a television or radio. Please handle it correctly per this documentation.

### Korean Compliance (KCC) Statement



Intel® products are tested and certified by KCC:  
RES3FV288

B급 기기  
(가정용 방송통신기자재)  
Class B Equipment  
(For Home Use Broadcasting & Communication Equipment)  
이 기기는 가정용(B급) 전자파적합기기로서 주로 가정에서 사용하는 것을 목적으로 하며, 모든 지역에서 사용할 수 있습니다.

This equipment is home use (Class B) electromagnetic wave suitability equipment and to be used mainly at home and it can be used in all areas.

### Taiwan Compliance



This equipment complies to class B Information Technology equipment based on VCCI (Voluntary Control Council for Interface). This equipment is designed for home use but it may causes radio frequency interference problem if used too near to a television or radio. Please handle it correctly per this documentation.

# Table of Contents

---

<b>Regulatory Compliance Statements</b> .....	<b>iii</b>
<b>About This Guide</b> .....	<b>1</b>
What You Need to Know Before You Begin .....	1
Terminology Used in this Guide .....	1
<b>Kit Contents and System Requirements</b> .....	<b>2</b>
Kit Contents .....	2
System Requirements .....	2
<b>About Your RAID Expander</b> .....	<b>3</b>
Standard RAID Expander Features .....	3
Major Components .....	4
Compatible Devices .....	4
Block Diagram .....	5
Board Dimensions .....	6
Mechanical Information .....	6
About the Intel® RAID Expander Card RES3FV288 .....	7
<b>Installing and Connecting the RAID Expander</b> .....	<b>8</b>
Before You Begin .....	8
Replacing the Full-Height Bracket with a Low-Profile Bracket .....	8
Selecting Disk Drives and Cables .....	11
Disk Drives .....	11
Cables .....	11
SAS Connectors .....	12
Installing the RAID Expander .....	13
<b>Configuring the RAID Expander</b> .....	<b>16</b>
<b>Solving Problems</b> .....	<b>17</b>
Troubleshooting Checklist .....	17
<b>A. Safety Information</b> .....	<b>18</b>
Electrostatic Discharge (ESD) .....	18
<b>B. Technical Specifications</b> .....	<b>19</b>
Environmental Specifications .....	19
DC Power Requirements .....	19
Current Requirements .....	20

# 1 About This Guide

---

This Installation and User's Guide explains how to install and configure your RAID Expander RES3FV288 in a RAID system.

## What You Need to Know Before You Begin

You should be familiar with computer hardware, data storage, and Serial Attached SCSI (SAS) and Serial ATA (SATA) technology.

You should also be familiar with RAID controllers, modules, expanders, and related support devices.

## Terminology Used in this Guide

Many of the terms and concepts referred to in this guide are known to computer users by multiple names. This guide uses these terms:

- Expander Card (also known as adapter, board, or I/O card)
- Disk drive (also known as hard disk, hard drive, or hard disk drive)
- Solid State Drive (also known as SSD or non-rotating storage media)
- Enclosure (also known as storage enclosure, JBOD enclosure, or expander)

## 2 Kit Contents and System Requirements

---

This section lists the contents of your kit and the system requirements for successfully installing and using your expander card.

### Kit Contents

- RAID Expander
- Low-profile bracket

### System Requirements

- An Intel® Server Board based on the Intel® Xeon® processor E5-2600 v3 product family
- Available compatible PCI Express\* x4 connector or available RA 4-pin power connector
- SAS or SATA hard drives up to 12 Gb/s speed
- Full height or low profile brackets



# 3 About Your RAID Expander

---

This section provides an overview of the features of your RAID Expander.

## Standard RAID Expander Features

- Support for both SAS and SATA devices
- 12 Gb/s, 6 Gb/s, 3 Gb/s, or 1.5 Gb/s data transfer rate
- Seven SFF-8643 mini-SAS-HD internal connectors and two external SFF-8644 connectors providing 36 SAS/SATA ports
- Supports up to 8 inputs and 28 outputs configuration
- Output mini-SAS connectors support sideband SGPIO per the SFF-8485 specification
- Power from a standard PCI Express\* x4 connector or RA 4-pin power connector
- Board functioning either in PCI Express slot or remotely in system
- On-board screw holds allow the expander card to be mounted on a chassis wall inside a server system
- Low profile and MD2 compliance
- Provides a low-latency connection to create and maintain transparent access to each connected SAS/SATA physical drive
- Staggered spin-up
- Native Command Queuing
- Allows multiple initiators to address a single target
- Supports cascaded expander products
- Each port on the expander card supports SAS devices, SATA II devices, or both using SSP, SMP, and STP
  - Serial SCSI Protocol (SSP) to enable communication with other SAS devices
  - Serial Management Protocol (SMP) to share topology management information with expanders
  - Serial Tunneling Protocol (STP) support for SATA II through expander interfaces
  - SAS protocol, described in the Serial Attached SCSI (SAS) Standard, version 2.0
  - SFF-8485 protocol, using the Serial GPIO (SGPIO) interface provided by the expander

- Enclosure Management
  - On-board temperature sensor
  - SGPIO

## Major Components

- 36-Port 12 Gb/s SAS-3 Expander Chip
  - Provides 36 PHYs
    - ✧ Any PHYs may be combined into wide port(s)
    - ✧ Any PHY can be SAS or SATA attached
  - Supports multiple data rates and auto-negotiation between the following:
    - ✧ 3.0 Gb/s, 6.0 Gb/s, and 12.0 Gb/s SAS
    - ✧ 3.0 Gb/s and 6.0 Gb/s SATA
  - Supports SSP, STP, and SMP
  - Supports the SAS protocol described in the Serial Attached SCSI (SAS) Standard, version 3.0r5
  - Activity and fault indicators per PHY
  - Provides a low-latency connection router to efficiently create and maintain connections
  - Supports T10-Based and Phy-Based Zoning for storage partitioning
  - Allows any number of phys to be included in a wide port
  - Provides up to 12 I<sup>2</sup>C interfaces
- Flash ROM – A 128-Mbit Quad SPI flash ROM is used to accommodate expander card firmware.
- Heartbeat LED – A green LED provides a heartbeat with a 1 second blink rate to indicate the expander has booted properly.
- SAS connectors – The RES3FV288 RAID Expander provides internal and external SAS connectors as shown in [SAS Connectors on page 12](#).

## Compatible Devices

- 2.5-inch and 3.5-inch SAS-3, SAS-2, and SATA drives
- Non-disk devices including SAS expanders
- Supports drives of mixed capacity
- SAS-3 and SAS-2 host controllers (RAID and Non-RAID)

# Block Diagram

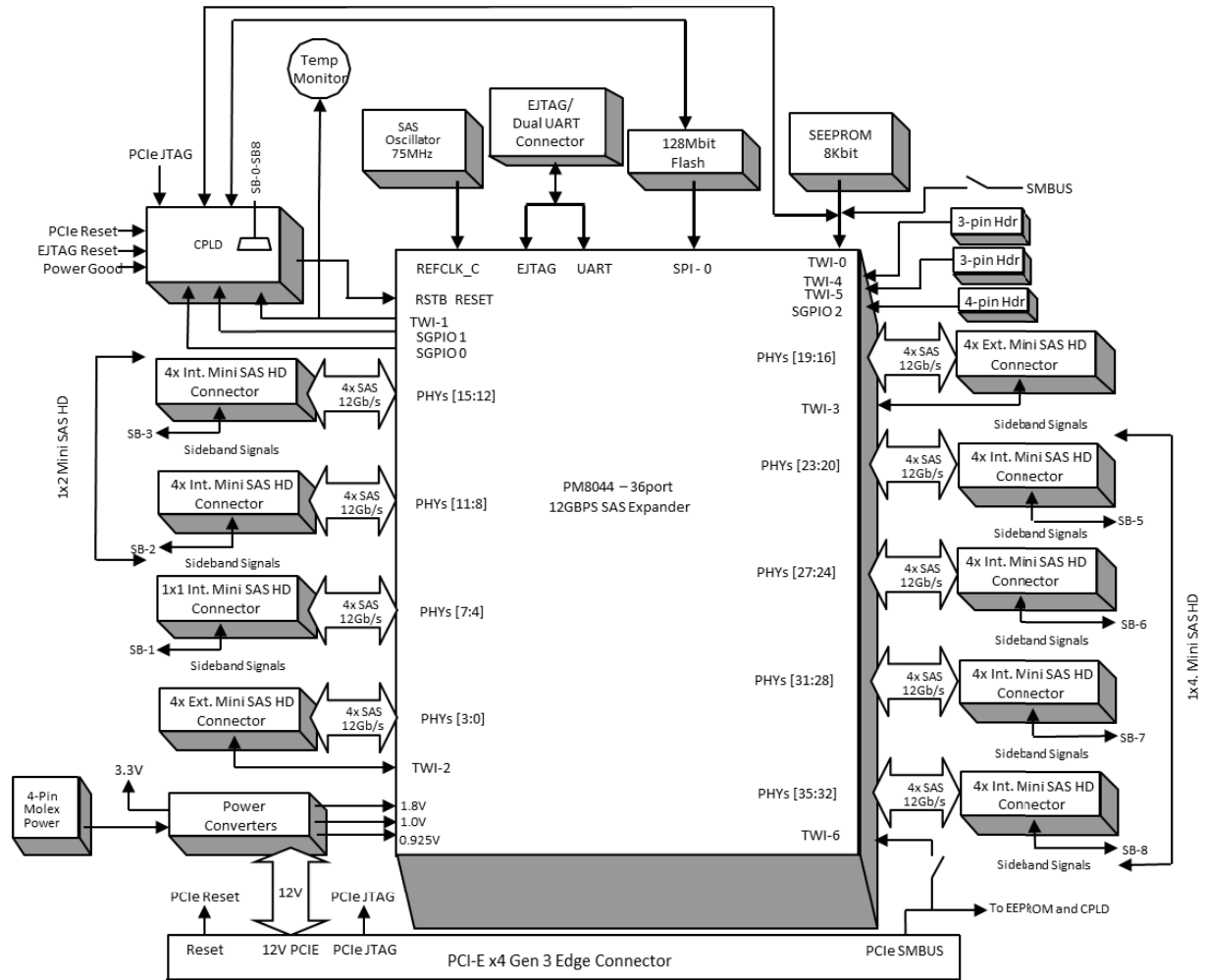

## Board Dimensions

The table below lists the board dimensions of your RAID Expander RES3FV288.

Dimension	RAID Expander RES3FV288
Height	2.535"
Length	6.00"
PCB Thickness	0.062"
Max Component Height, Top Side	0.570"
Max Component Height, Bottom Side	0.105"

## Mechanical Information

The figure below shows the physical package information for the RAID Expander RES3FV288. All dimensions are in inches.

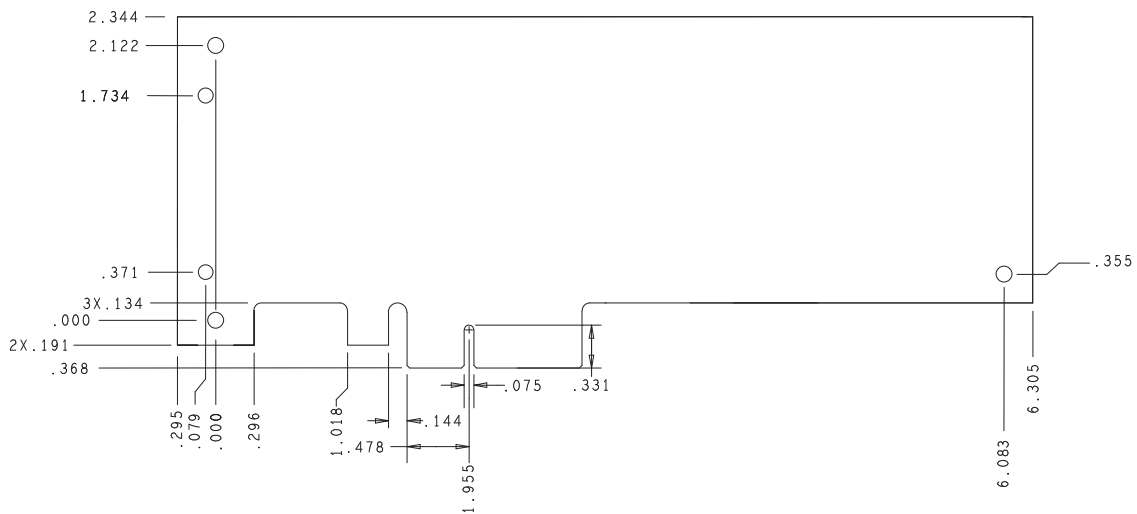

# About the Intel® RAID Expander Card RES3FV288

The RAID Expander RES3FV288 is a RAID expander with these features:

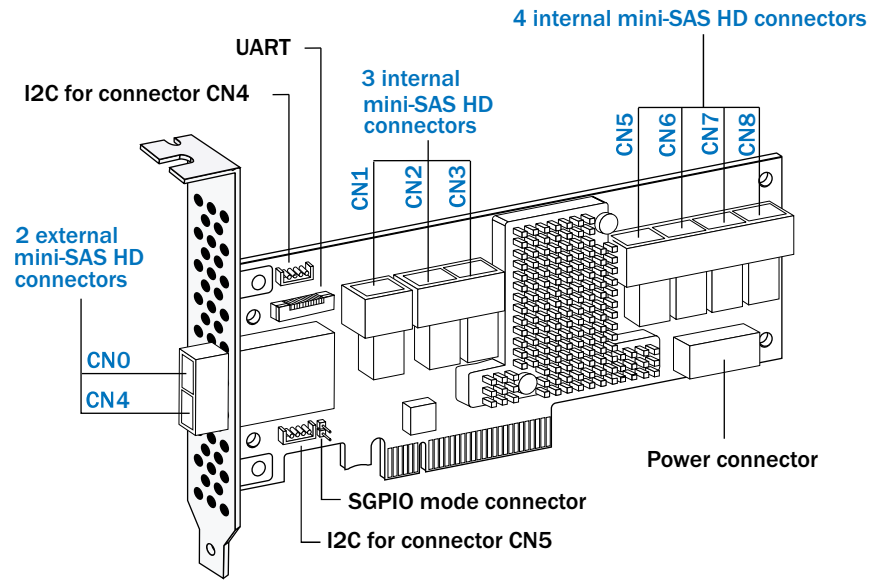

Form Factor	Low-profile MD2 SFF card size
Bus compatibility	PCIe
PCIe bus width	x4
Data transfer rate	12 Gb/s per port
Phys (Unified Serial Ports)	36
Connectors, external	1 mini-SAS HD x2 (SFF-8644) 8 ports
Connectors, internal	1 mini-SAS HD x1 1 mini-SAS HD x2 1 mini-SAS HD x4 (SFF-8643) 28 ports
Maximum number of disk drives	up to 24 direct-attached
Enclosure Support	SES-3
Thermal Sensor	Processor temperature
Encryption	No

# 4 Installing and Connecting the RAID Expander

---

This section explains how to install your RAID Expander and connect it to internal and external disk drives.

## Before You Begin

- Read [Appendix A: Safety Information](#).
- Familiarize yourself with your product's physical features (see [Standard RAID Expander Features on page 3](#)).
- Ensure that you have the right number of drives and cables for your application (see [Selecting Disk Drives and Cables on page 11](#)).

## Replacing the Full-Height Bracket with a Low-Profile Bracket

If you are installing your RAID Expander into a low-profile computer cabinet, replace the original full-height bracket with the low-profile bracket included in your distribution kit. The full-height bracket is mounted on the front of the expander, and the low-profile bracket is mounted on the back, as shown in the figures below.

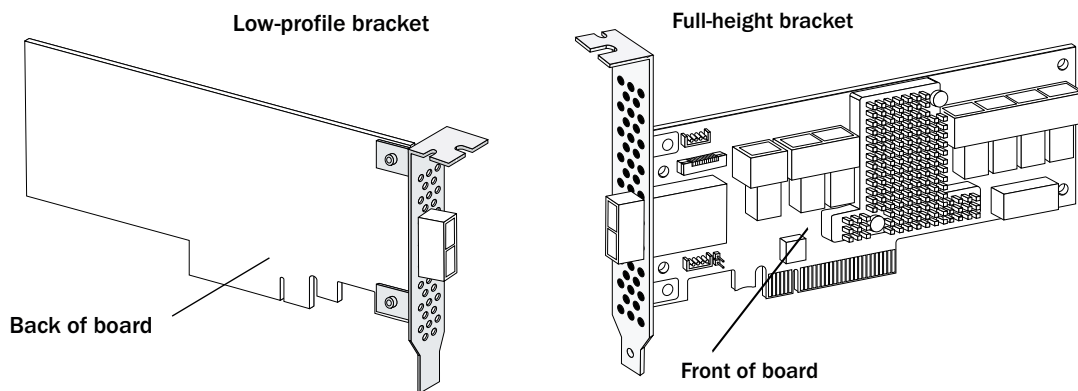

To replace the full-height bracket with the low-profile bracket:

1. Remove the full-height bracket from the expander card. The full-height bracket is installed on the front side of the expander, with the mounting screws inserted from the back (see Figure 1). Using a Phillips head screw driver, remove the mounting screws, as shown in Figure 2, then set the screws aside for use in the next step.

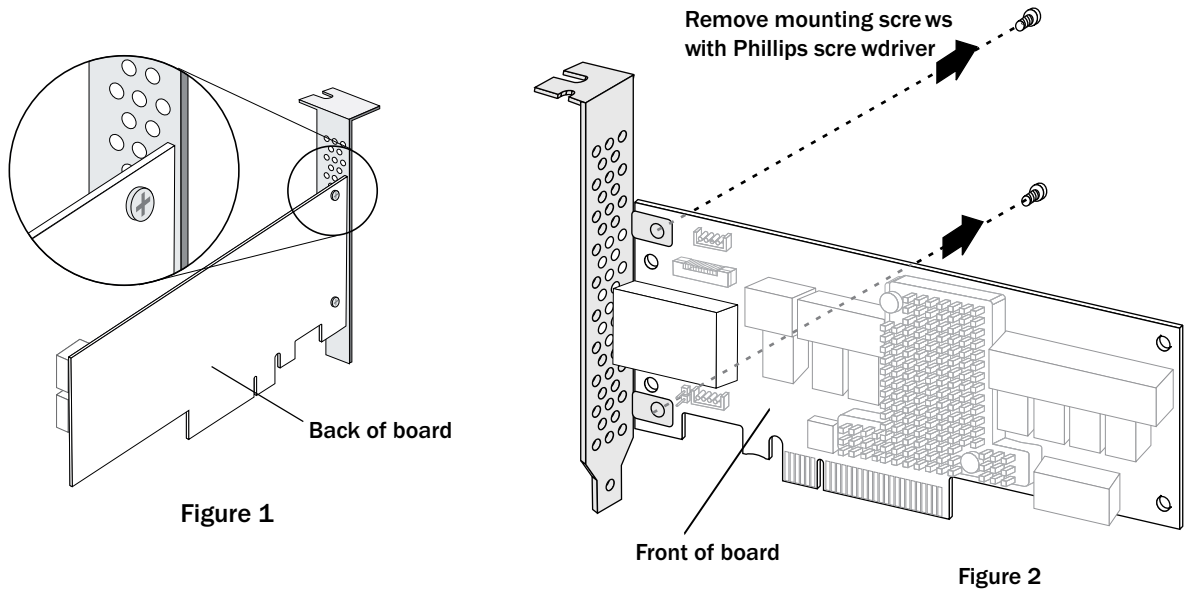

2. Attach the low-profile bracket to the expander card. The low-profile bracket is installed on the back side of the expander, with the mounting screws inserted from the front, as shown the Figure 3.

Insert the screws through the holes on the front of the expander, then fasten the screws to the bracket with a Phillips screw driver.

**Caution:** The mount points on the low-profile bracket have a smooth or flat side and a raised side that looks like a spacer (see Figure 3). Be sure to install the bracket with the flat side against the expander card and the raised side facing away from the expander card.

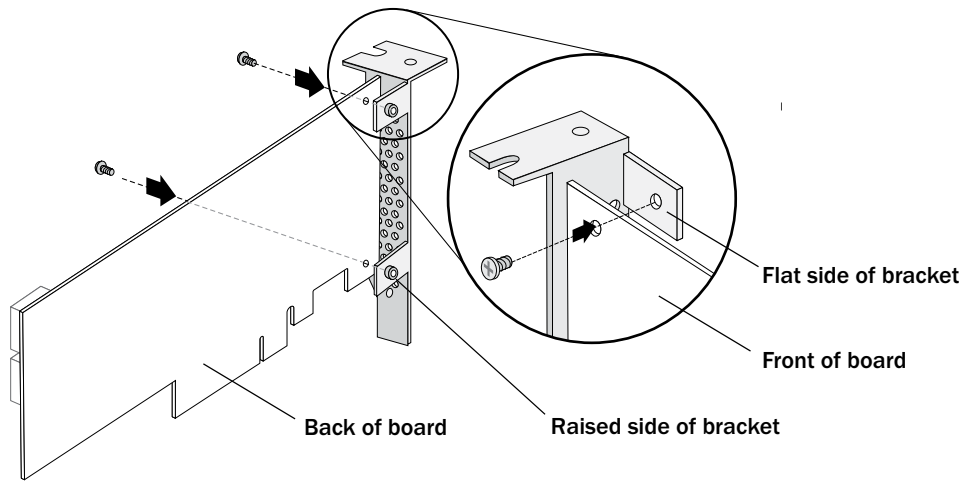

**Figure 3**

**Caution:** *The torque on the mounting screws should be a maximum of 3.0-4.0 lbf-in to avoid deformation. Be sure that the expander is not bent after attaching the low-profile bracket to the expander card.*



# Selecting Disk Drives and Cables

## Disk Drives

Your RAID Expander supports SAS and SATA disk drives, Solid State Drives (SSDs), and SAS tape drives.

## Cables

Depending on your application requirements, you can use any of the cables listed below.

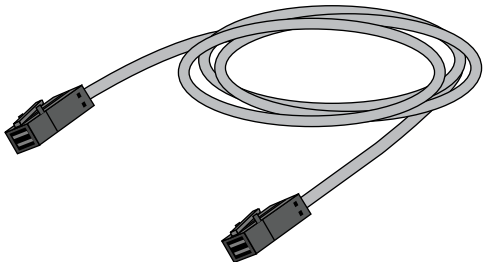
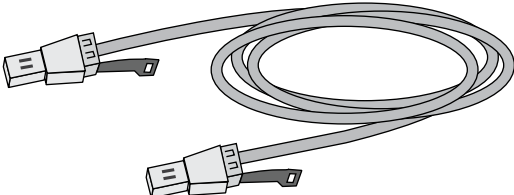
<b>Cables</b>	
	Internal HD mini-SAS to HD mini-SAS (SFF-8643 to SFF-8643) – Connects to a backplane or enclosure.
	External HD mini-SAS to HD mini-SAS (SFF-8644 to SFF-8644) – Connects to a backplane or enclosure.

## SAS Connectors

This section shows the internal and external SAS connectors.

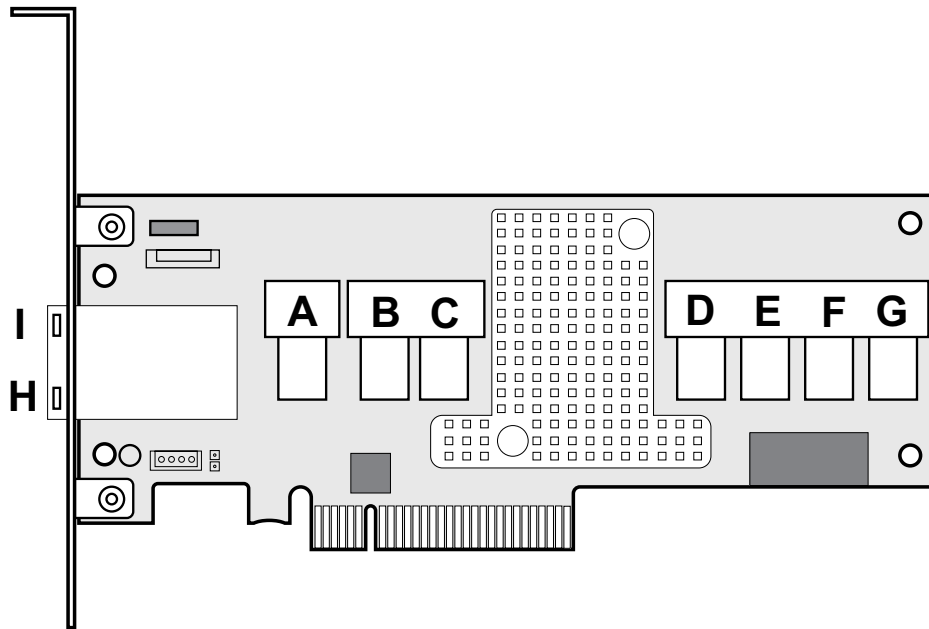

Connector	Description	Type	Comment
A	1x1 HD mini-SAS internal	SFF-8643	A – SAS ports (0-3)
B, C	1x2 HD mini-SAS internal	SFF-8643	B – SAS ports (4-7) C – SAS ports (8-11)
D, E, F, G	1x4 HD mini-SAS internal	SFF-8643	D – SAS ports (12-15) E – SAS ports (16-19) F – SAS ports (20-23) G – Wide port to HBA
I, H	1x2 HD mini-SAS external	SFF-8644	I – External Wide Port H – External Wide Port

# Installing the RAID Expander

This section describes how to install the RAID Expander into your computer cabinet or server. The RAID Expander comes in two configurations:

- Expanders with internal connectivity
- Expanders with external connectivity

Follow the steps below to install your RAID Expander card and connect your internal or external storage devices.

**Caution:** *Be sure to handle the expander by its bracket or edges only.*

1. Turn off the power to the system, all drives, enclosures, and system components. Remove the power cord(s).
2. Remove the server cover. For instructions, see your server system documentation.
3. If necessary, change the bracket on the expander card to fit the height of the server system.
4. Select an available PCIe expansion slot that's compatible with your expander card and remove the slot cover, as shown in the figure below. (To check PCIe bus compatibility of your expander, see [About Your RAID Expander on page 3.](#))

**Caution:** *Touch a grounded metal object before handling the expander card.*

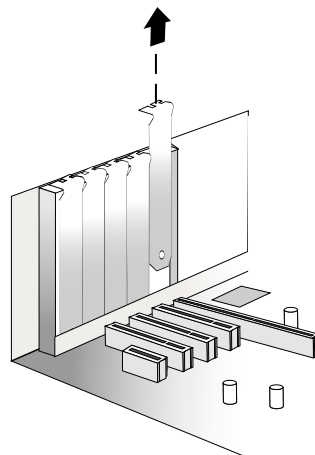

5. Insert the expander card into the expansion slot and press down gently but firmly until it clicks into place. When installed properly, the expander card should appear level with the expansion slot.

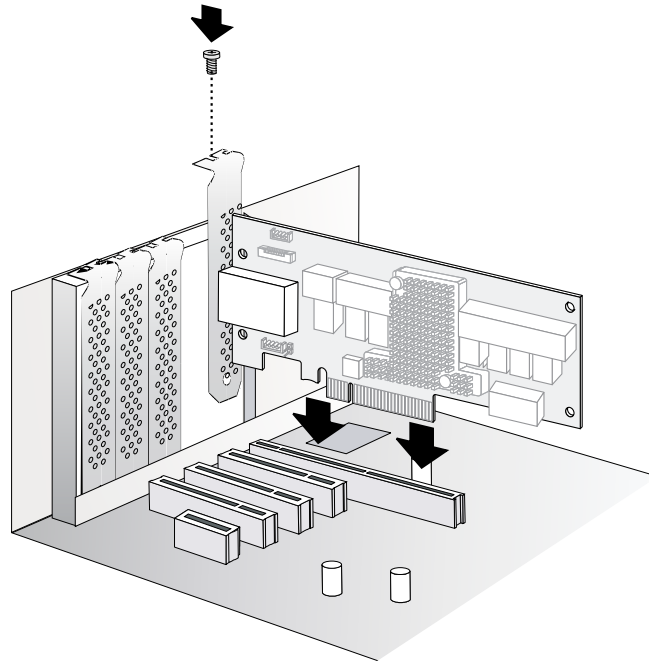

6. Secure the bracket in the expansion slot, using the retention device (for instance, a screw or lever) supplied with your computer.
7. Connect serial cables between the expander card and internal or external disk drives, as required:
  - For an expander card with external ports, connect serial cables between the expander card and external disk drives or enclosures:

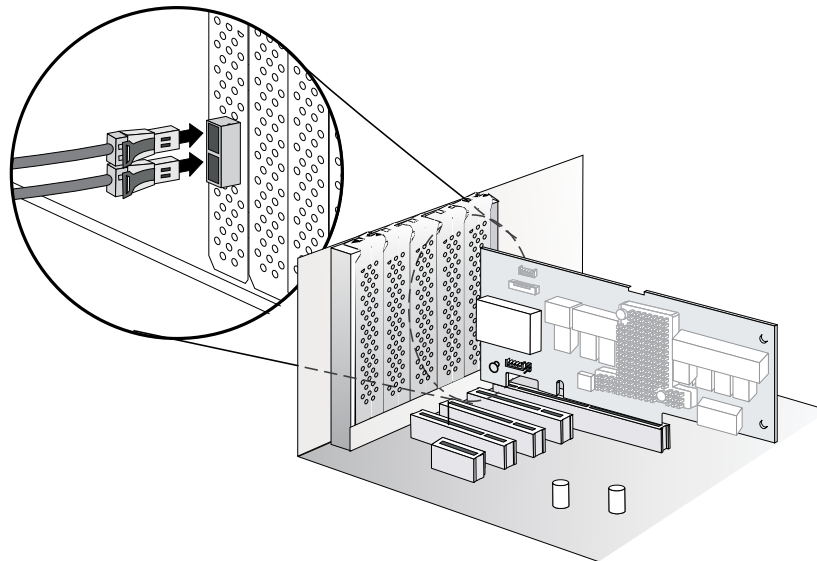

- For an expander card with with internal ports, connect serial cables between the expander card and internal disk drives:

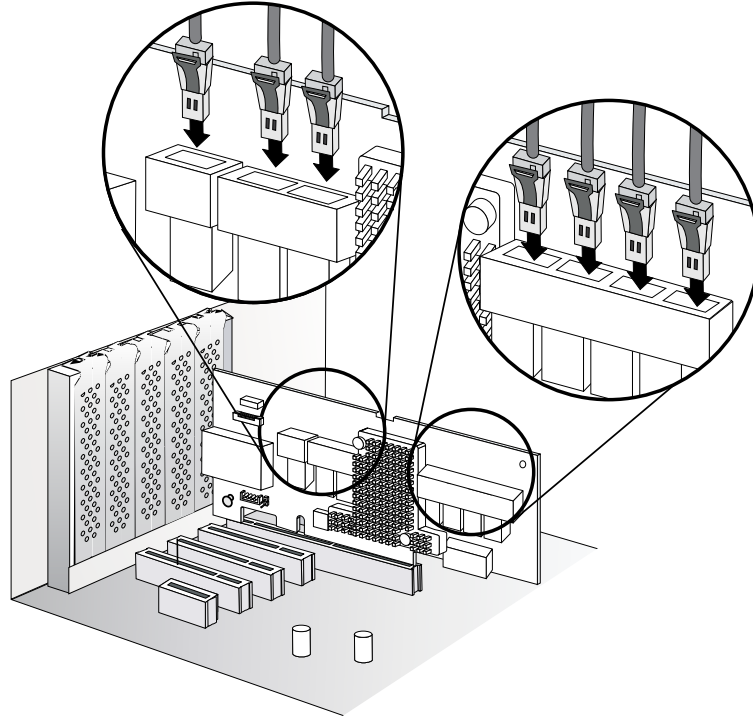

8. Close your computer cabinet, reconnect the power cord and network cables, then power up the system.

# 5 Configuring the RAID Expander

---

After physically installed into a server system, the RES3FV288 RAID Expander is transparent to users in RAID configurations. Refer to the technical specification or user guide of the RAID controller connected to this expander card to know how to configure a RAID system.

# 6 Solving Problems

---

This section provides basic troubleshooting information and solutions for solving problems with your RAID Expander.

## Troubleshooting Checklist

If you encounter difficulties installing or using your RAID Expander, check these items first:

- With your computer powered off, check the connections to each disk drive, power supply, LED connector, and so on.
- Try disconnecting and reconnecting disk drives from the expander.
- Check that your expander is installed in a compatible PCIe expansion slot. To double-check the bus compatibility of your expander, see [About Your RAID Expander on page 3](#).
- Ensure that your expander is firmly seated and secured in the PCIe expansion slot.
- If your expander is not detected during system boot, try installing it in a different compatible expansion slot. (See [Installing the RAID Expander on page 13](#) for instructions.)
- Did the RAID controller driver install correctly?
- If you have external disk drives (or other devices), are they powered on?

# Appendix A: Safety Information

---

To ensure your personal safety and the safety of your equipment:

- Keep your work area and the computer clean and clear of debris.
- Before opening the system cabinet, unplug the power cord.

## Electrostatic Discharge (ESD)

**Caution:** *ESD can damage electronic components when they are improperly handled, and can result in total or intermittent failures. Always follow ESD-prevention procedures when removing and replacing components.*

To prevent ESD damage:

- Use an ESD wrist or ankle strap and ensure that it makes skin contact. Connect the equipment end of the strap to an unpainted metal surface on the chassis.
- Avoid touching the expander against your clothing. The wrist strap protects components from ESD on the body only.
- Handle the expander by its bracket or edges only. Avoid touching the printed circuit board or the connectors.
- Put the expander down only on an anti-static surface such as the bag supplied in your kit.

If a wrist strap is not available, ground yourself by touching the metal chassis before handling the expander or any other part of the computer.



# Appendix B: Technical Specifications

---

## Environmental Specifications

**Note:** Your RAID Expander requires adequate airflow to operate reliably. The recommended airflow is 200 LFM (linear feet per minute), minimum to avoid operating above the maximum ambient temperature. Forced airflow is required.

- The thermal and atmospheric characteristics are:

Ambient temperature with forced airflow	0°C to 55°C
Relative humidity	20% to 80%, non-condensing
Altitude	Up to 3,000 meters

The storage and transit environment conditions are:

Ambient temperature with forced airflow	-30°C to 80°C (dry bulb)
Relative humidity	5% to 90%, non-condensing
Mean Operating Time Between Failures number (MTBF): electrical components	1M hours at 40°C

**Note:** Ambient temperature is measured 1" from the expander processor.

## DC Power Requirements

Bus Type	Description	Requirements
PCIe	Ripple and noise	<b>RAID Expander</b> 12V: TBD mV peak-to-peak (max)
PCIe	DC Voltage	12V ± 5%

# Current Requirements

Product	Typical Current
RAID Expander RES3FV288	1.34A @ 12 VDC
RAID Expander RES3FV288	All power is supplied to the RES3FV288 RAID Expander through the standard PCI Express connector's 12 V rails, or a remote RA 4-pin 12V power connector. The +12 V rail is used to generate the other required voltage rails of 3.3V, 1.8V, 1.005V, and 0.925V and +1.8 V.