

English



HP LaserJet 8100, 8100 N,
and 8100 DN Printers
Getting Started Guide

HP LaserJet 8100, 8100 N, and 8100 DN Printers

Getting Started Guide _____

© Copyright Hewlett-Packard Company 1998

All Rights Reserved.
Reproduction, adaptation, or translation without prior written permission is prohibited, except as allowed under the copyright laws.

Publication number
C4214-90901
Reorder number
C4214-99001

First Edition, October 1998

Warranty

The information contained in this document is subject to change without notice.

Hewlett-Packard makes no warranty of any kind with respect to this information.
HEWLETT-PACKARD SPECIFICALLY DISCLAIMS THE IMPLIED WARRANTY OF MERCHANTABILITY AND FITNESS FOR A PARTICULAR PURPOSE.

Hewlett-Packard shall not be liable for any direct, indirect, incidental, consequential, or other damage alleged in connection with the furnishing or use of this information.

Trademark Credits

PostScript is a trademark of Adobe Systems Incorporated which may be registered in certain jurisdictions.

Arial, Monotype, and Times New Roman, are U.S. registered trademarks of the Monotype Corporation.

CompuServe is a U.S. trademark of CompuServe, Inc.

Helvetica, Palatino, Times, and Times Roman are trademarks of Linotype AG and/or its subsidiaries in the U.S. and other countries.

Microsoft, MS Windows, Windows and Windows NT are U.S. registered trademarks of Microsoft Corporation.

TrueType is a U.S. trademark of Apple Computer, Inc.

ENERGY STAR is a U.S. registered service mark of the U.S. EPA.

Contents

Installation Checklist	2
Step 1 Prepare Printer Location	3
Step 2 Check Package Contents	5
Step 3 Remove Internal Packaging	6
Step 4 Locate Printer Parts	7
Step 5 Install Accessories	8
Step 6 Install Toner Cartridge.	9
Step 7 Load Trays 2 and 3.	11
Step 8 Load Tray 1 (Optional)	13
Step 9 Attach Power Cord	15
Step 10 Install or Change the Control Panel Overlay (Optional)	16
Step 11 Configure the Control Panel Display Language (Optional)	17
Step 12 Test the Printer	18
Step 13 Connect Printer Cables	19
Step 14 Install Printing Software	22
Step 15 Install Online User Guide	25
Step 16 Install Ready Reference Guide Holder	29
Step 17 Verify Printer Setup.	30

Printer Setup

Congratulations on your purchase of the HP LaserJet 8100 series printer! This printer is available in three configurations:

HP LaserJet 8100 printer

The HP LaserJet 8100 printer comes standard with 16 MB RAM, wide format printing, two 500-sheet trays, and a 100-sheet multipurpose tray.

Note

The HP LaserJet 8100 requires an optional EIO card to connect to a Macintosh.

HP LaserJet 8100 N printer

The HP LaserJet 8100 N printer comes standard with 16 MB RAM, wide format printing, two 500-sheet trays, a 100-sheet multipurpose tray, and an HP JetDirect 600N print server.

HP LaserJet 8100 DN printer

The HP LaserJet 8100 DN printer comes standard with 24 MB RAM, wide format printing, two 500-sheet trays, a 100-sheet multipurpose tray, an HP JetDirect 600N print server, and a duplexer (for printing on both sides of paper).

Installation Checklist

This guide will help you set up and install the new printer. For proper installation, please complete each section in order:

- Unpack the printer steps 1-4
- Install the printer steps 5-12
- Connect the printer cables step 13
- Install printing software step 14
- Install online user guide step 15
- Attach holder for ready reference guide step 16
- Verify printer setup step 17

WARNING!

The printer is heavy. HP recommends that four people move it.

Note

To learn about all the features and capabilities of the printer, see the printer user guide and the help menus in the printer drivers (available after you install the printing software and online user guide).

Step 1 Prepare Printer Location

Printer Size

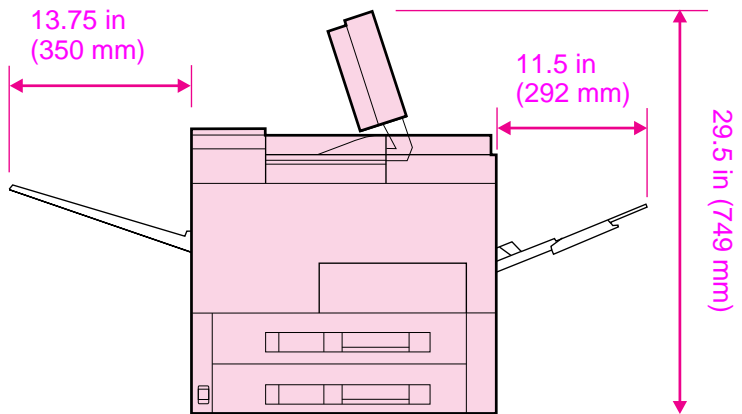
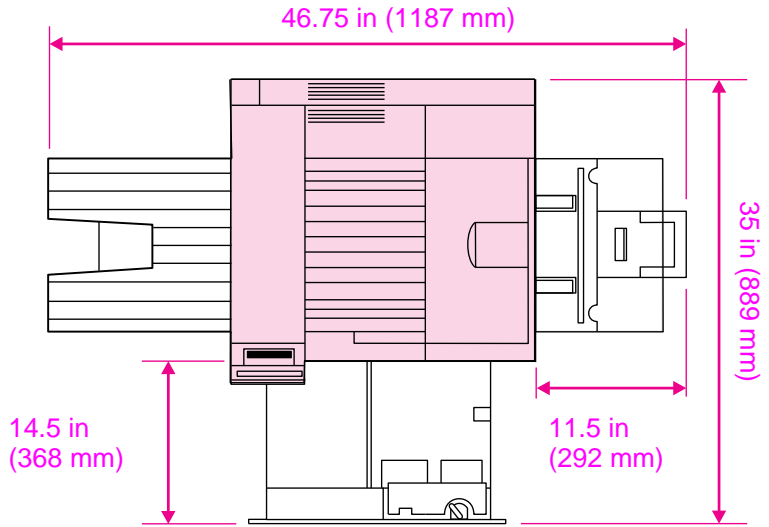

HP LaserJet 8100 Printer Dimensions (Top and Side Views)

Location requirements for the printer

- A sturdy, level surface for placement
- Space allowance around the printer
- A well ventilated room
- No exposure to direct sunlight or chemicals, including ammonia-based cleaning solutions
- Adequate power supply
- A stable environment—no abrupt temperature or humidity changes
- Relative humidity 20% to 80%
- Room temperature 50° to 91° F (10° to 32.5° C)

Printer Weight (without toner cartridge)

- HP LaserJet 8100 and 8100 N printers: 51 kg (112 lbs)
- HP LaserJet 8100 DN printer: 54 kg (120 lbs)

Step 2 Check Package Contents

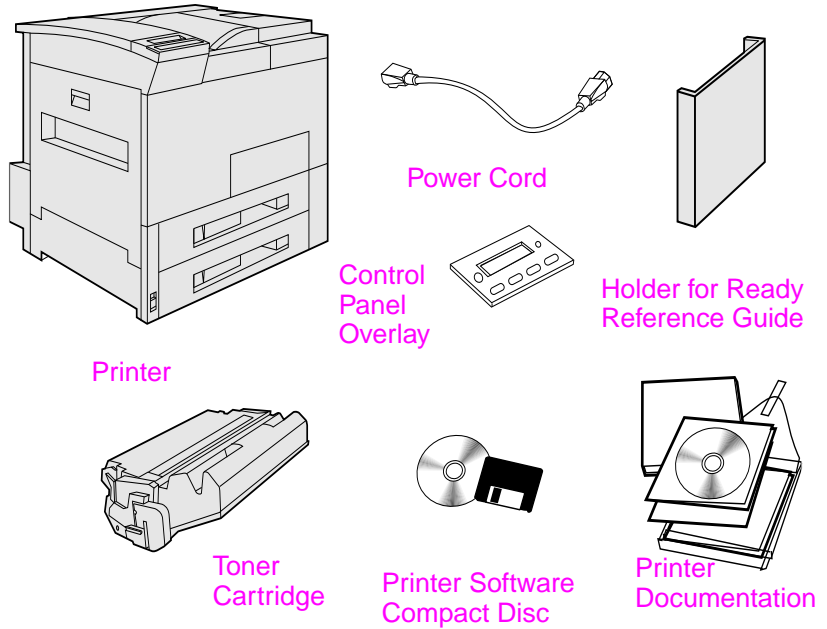

Package Contents

Note

A printer interface cable is not included in the package contents. See the printer user guide for ordering information.

Step 3 Remove Internal Packaging

1

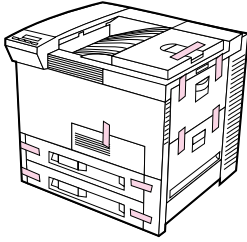

2

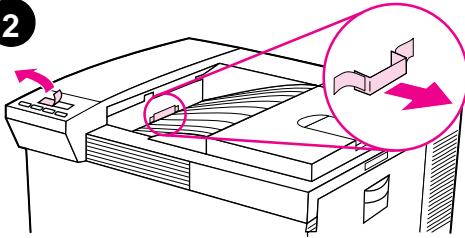

3

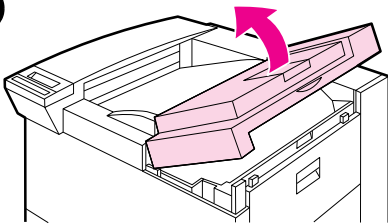

4

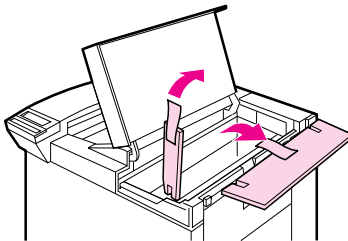

5

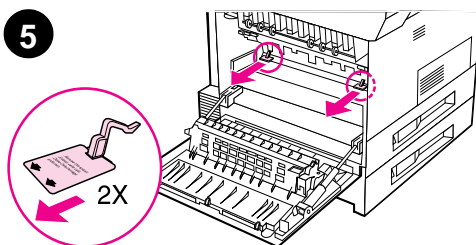

Note

Save all packing material. You may need to repack the printer at a later date.

WARNING!

This printer weighs approximately 51 kg (112 lbs). HP recommends that four people move it.

- 1 Remove all external packing tape from the printer.
- 2 Remove packing material from standard output bin and protective film from display.
- 3 Open the top cover.
- 4 Remove packing material and tape and close top cover.
- 5 Open the left-side door and remove the two packing spacers. Close the door.

Step 4 Locate Printer Parts

The following illustrations give the location and names of the important printer parts.

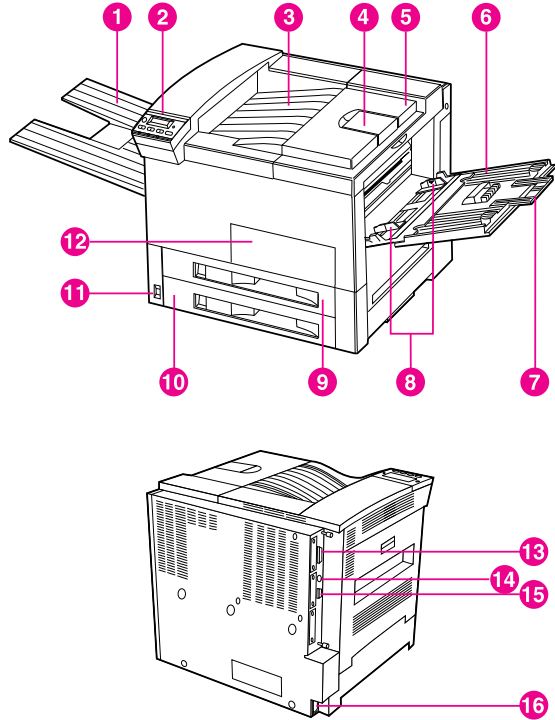

Printer Parts (front and rear views)

-
- | | | | | | |
|---|-----------------------|----|---------------------------|----|--------------------------|
| 1 | Face-up Bin | 6 | Tray 1 (multipurpose) | 12 | Front Door |
| 2 | Control Panel | 7 | Tray 1 extensions | 13 | Parallel Cable Connector |
| 3 | Standard Output Bin | 8 | Tray 1 paper width guides | 14 | HP Fast InfraRed Connect |
| 4 | Adjustable Paper Stop | 9 | Tray 2 | 15 | C-Link Connector |
| 5 | Top Cover | 10 | Tray 3 | 16 | Power Cord Connector |
| | | 11 | Power Switch | | |
-

Step 5 Install Accessories

Install any accessories that you have purchased with the printer. Use the installation instructions that are packaged with the accessories.

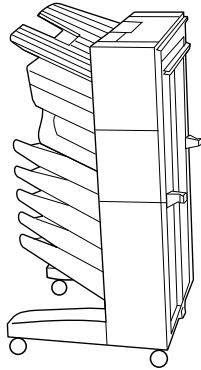

Multibin Mailbox (5-Bin with Stapler)

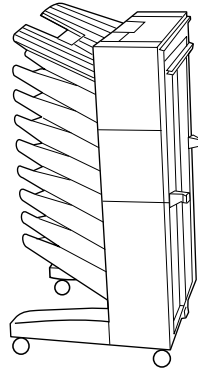

Multibin Mailbox (8-Bin)

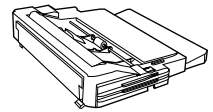

Duplexer

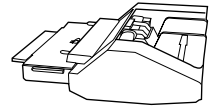

Envelope Feeder

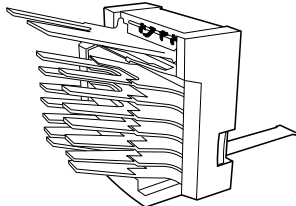

7-bin Tabletop Mailbox



HP Fast InfraRed Connect

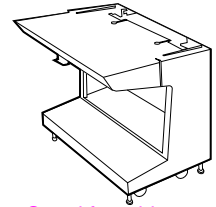

Stand for 7-bin Tabletop Mailbox

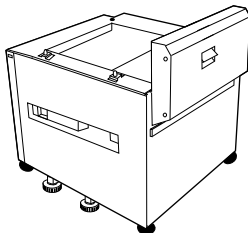

2000-sheet Input Tray

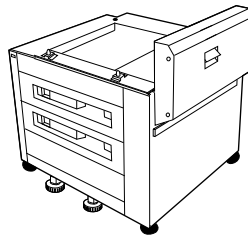

2 x 500-sheet Input Tray

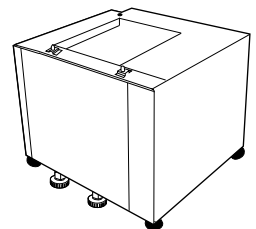

Printer Stand

Optional Accessories

Step 6 Install Toner Cartridge

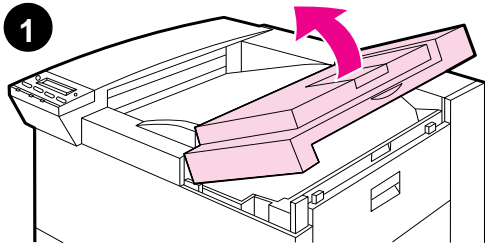

- 1 Open the printer's top cover.
- 2 Remove the toner cartridge from its packaging. (Save packaging for possible cartridge storage.)

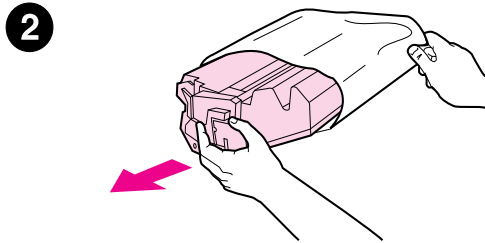

Note

To prevent damage to the toner cartridge, do not expose it to light for more than a few minutes.

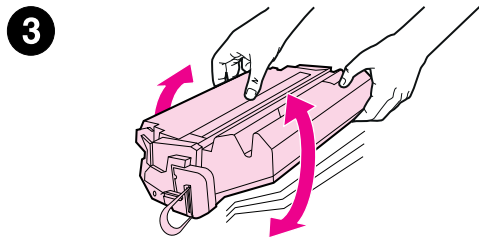

- 3 Rotate the cartridge and gently shake it from side to side to distribute the toner evenly inside the cartridge.
- 4 Locate the sealing tape tab on the end of the cartridge. Carefully bend the tab back and forth until it separates from the cartridge.

Continued on the next page.

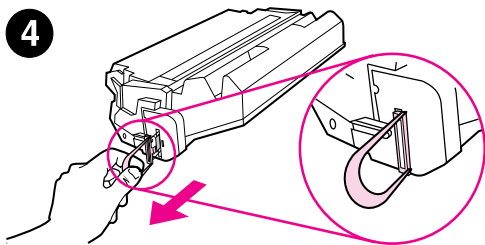

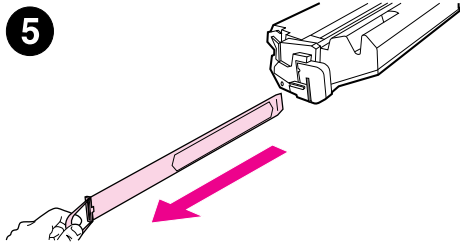

- 5 Firmly pull the tab straight out from the cartridge to remove the entire length of tape. Avoid touching any black toner on the tape.

Note

If the tab separates from the tape, grasp the tape and pull it out of the cartridge.

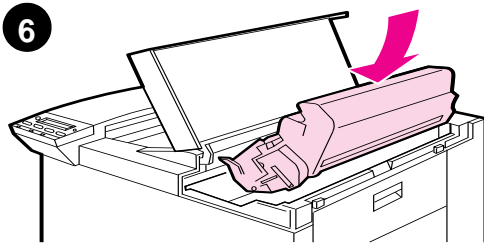

Note

If toner gets on your clothing, wipe it off with a dry cloth and wash clothing in cold water. (Hot water sets toner into fabric.)

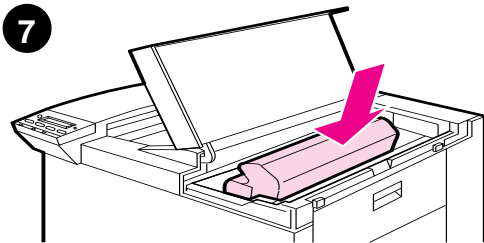

- 6 Position the cartridge as shown with the arrow pointing into the printer.
- 7 Slide the cartridge into the printer as far as it will go.
- 8 Close the top cover.

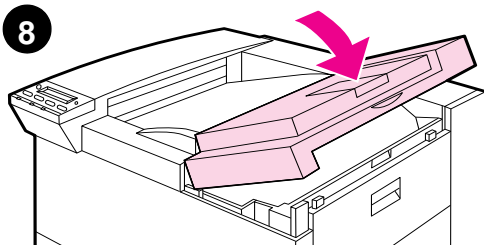

Step 7 Load Trays 2 and 3

1

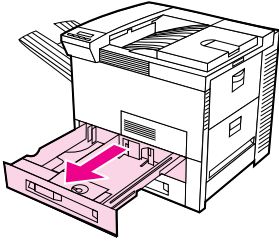

2

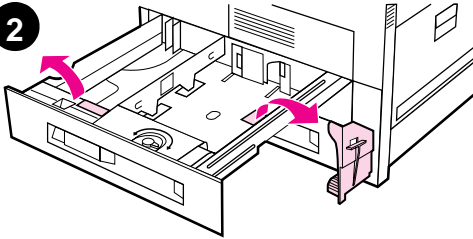

3

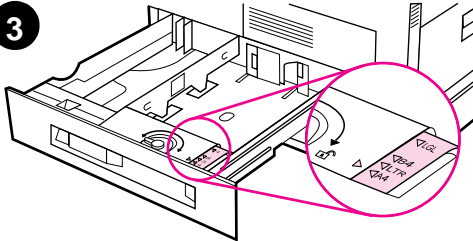

4

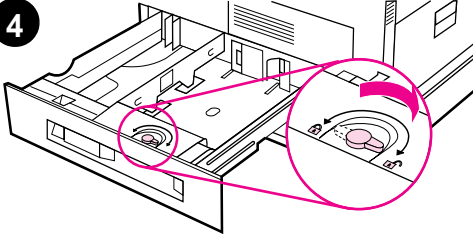

5

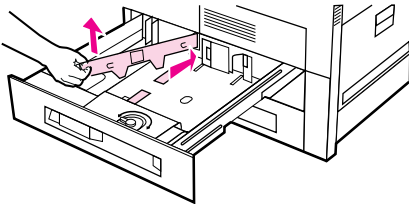

Note

The paper size setting is set to a default size at the factory. The default for the United States is letter-size, while in Europe it is A4. If you would like to use a different default paper size, reconfigure the paper tray setting.

- 1 Open Tray 2 until it stops.
- 2 Remove the packing spacer and tape.
- 3 If you wish to load paper that is different than the default size, turn the paper guide to the mark that indicates the size of paper you are loading.
- 4 Turn the paper guide to the locked position.
- 5 Adjust the left paper guide by pushing in, then lifting up and out.

Continued on the next page.

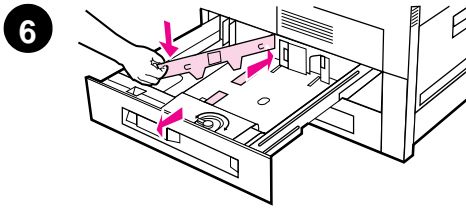

- 6 Position the guide over the appropriate lines marked in the tray. Press the guide into the rear slot and then lower down into the front slot. Be sure the guide is not skewed.

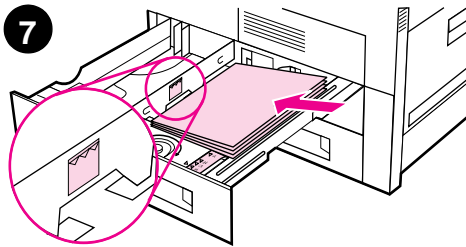

- 7 Insert up to 500 sheets of paper into the tray. Do not fill the input tray above the paper fill marks on the guide

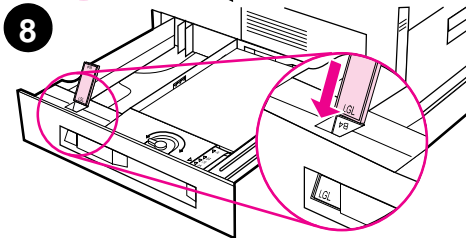

-
- Note**
For single-sided printing, place the side to be printed facing down. For double-sided printing, the front side should be facing up.
-

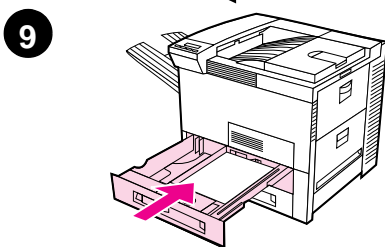

- 8 Make sure the paper size tab is set correctly.
- 9 Slide the tray back into the printer.

If you wish to select your paper by type rather than tray (source), see your online user guide.

If you wish to print on paper sizes larger than letter or A4, adjust the paper stop guide on the Standard Output Bin. (See your online user guide for instructions.)

-
- Note**
If paper curls or skews excessively during printing, open the tray and turn the stack of paper over. To avoid a paper jam, never open the tray while it is in use.
-

Step 8 Load Tray 1 (Optional)

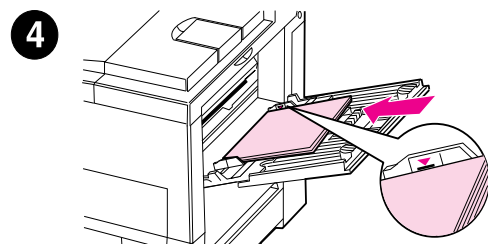
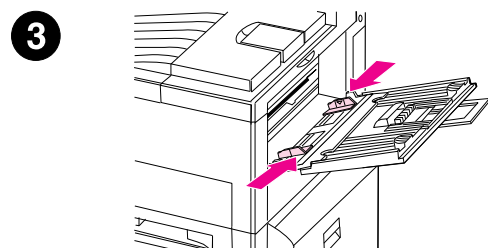
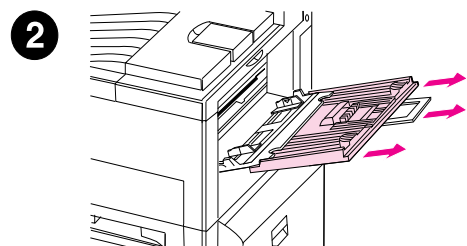
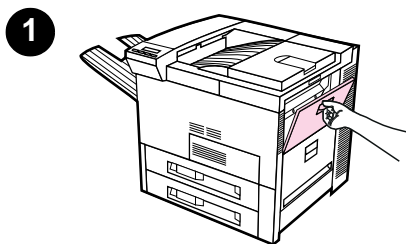

Tray 1 is a multi-purpose tray and holds up to 100 sheets of paper or 10 envelopes.

Tray 1 provides a convenient way to print envelopes, transparencies, custom-size paper, labels, or other types of media without having to unload the other trays.

CAUTION

To avoid a paper jam, never add or remove paper from Tray 1 while the printer is printing.

To avoid damaging the printer, print labels and transparencies from Tray 1 only. Send them to the Top Output Bin, do not print them on both sides, and remove them promptly.

Note

Paper loaded in Tray 1 will be printed first unless the Tray 1 setting is changed from the printer control panel. To change the order in which trays will be printed from, see your online user guide.

- 1 Open Tray 1.
- 2 Pull out the tray extension, if needed for the paper size you are printing.
- 3 Slide the paper width guides to the appropriate size marked on the tray.
- 4 Place paper into the tray without stacking it above the paperfill mark.

Continued on next page.

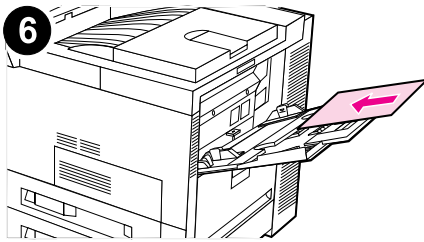
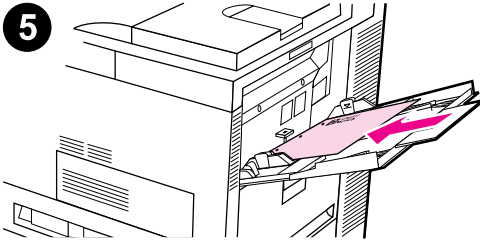

Note

For single-sided printing, place paper into the tray with the side-to-be-printed up. The top of the page (letterhead, for example) should be placed toward the rear of the printer. For two-sided printing, place paper with the front side down. For prepunched paper, always load with the holes toward the rear of the printer.

- 5 Load letter or A4 paper with the longer edge of the page leading into the printer.
- 6 Load envelopes, Executive, Legal, 11 x 17, ISO A3, JIS B5, or JIS B4 with the short edge of the page leading into the printer.

Note

Paper heavier than 28 lb (105 g/m²) should be printed from Tray 1 to the Face-up Bin to avoid curl.

Step 9 Attach Power Cord

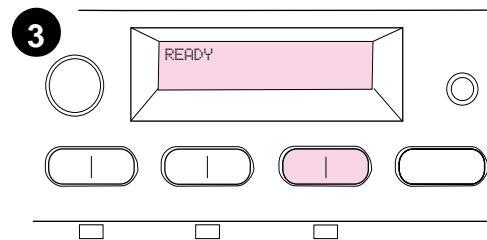
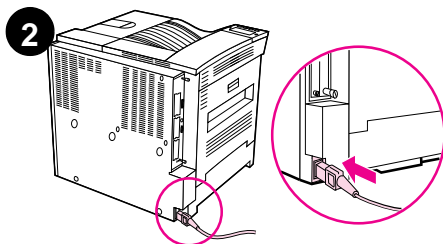
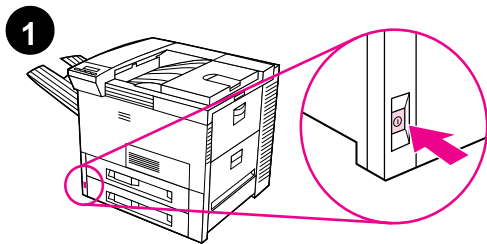

- 1 Locate the power switch on the front of the printer. Make sure the printer is turned off.
- 2 Connect the power cord to the printer and a grounded power strip or an AC outlet.
- 3 Turn the printer on. After the printer warms up, the **READY** message should appear on the control panel display and the Ready light should remain on. If the **READY** message does not appear, see the problem solving chapter in the online user guide.

Step 10 Install or Change the Control Panel Overlay (Optional)

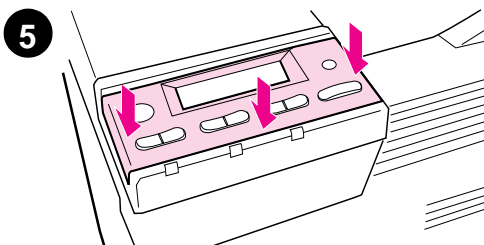
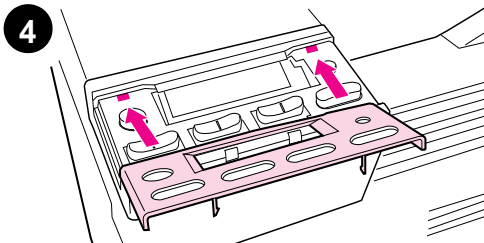
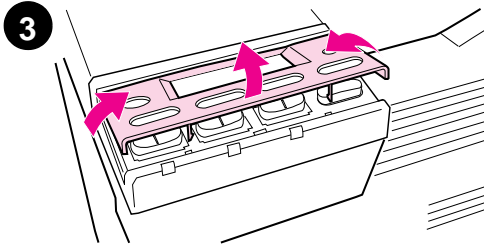
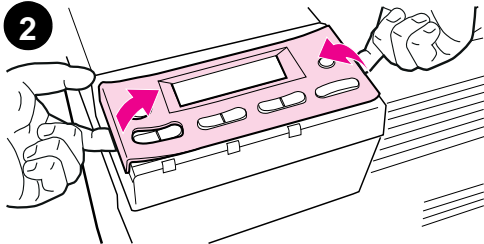
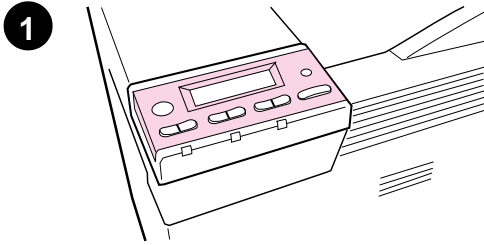

To change the overlay to a language other than English:

- 1 Locate the overlay you wish to install and remove it from its bag.

Note

Make certain the power switch is off.

- 2 Gently lift up on each side of the installed overlay.
- 3 Insert your thumbnail or a thin, rigid object in front of the overlay and press toward the back of the printer. Lift to remove.
- 4 To install the new overlay, position it over the control panel, rear-side first.
- 5 Snap the overlay firmly onto the control panel. Ensure that the overlay is flat.

Step 11 Configure the Control Panel Display Language (Optional)

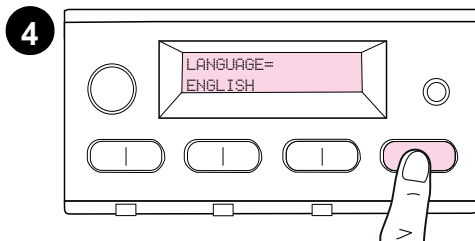
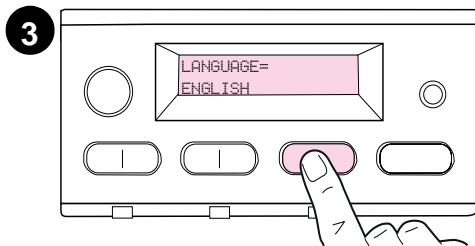
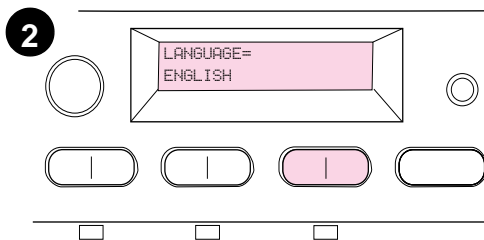
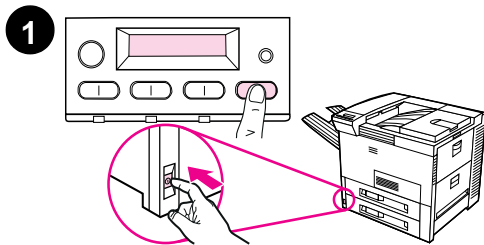

To configure the control panel to display a language other than English:

- 1 Press and hold **SELECT** while simultaneously pushing the power switch ON. Hold **SELECT** until **SELECT LANGUAGE** appears, then release **SELECT**.
- 2 **LANGUAGE=ENGLISH** will display.
- 3 Use the **VALUE -** and **VALUE +** keys to select the desired language.
- 4 Press **SELECT** to save your selection. The control panel display will indicate the printer is ready to use.

Note

If the new language does not appear in the display, you may not have pressed **SELECT** to save your new selection.

Step 12 Test the Printer

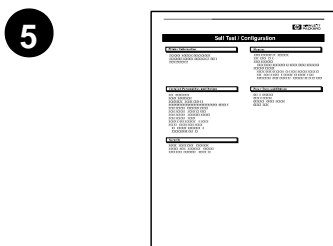
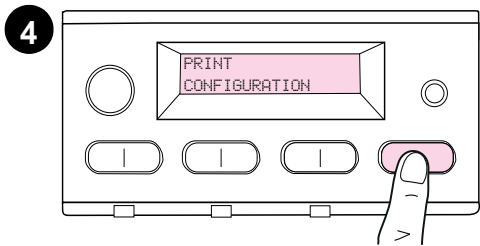
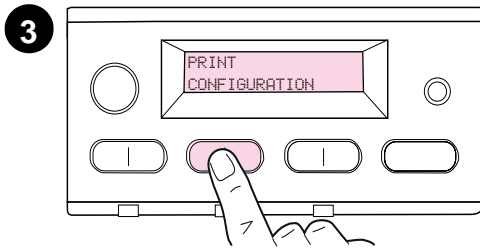
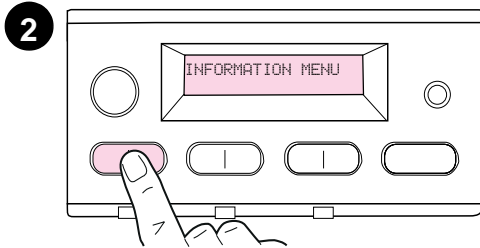
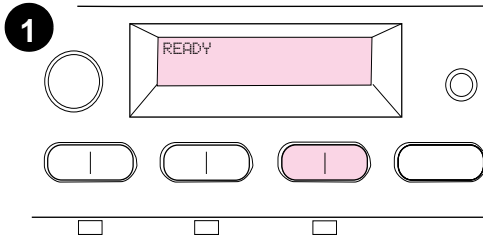

Print a configuration page to make sure the printer is operating correctly.

- 1 Make sure the printer is on and the READY message is displayed.
- 2 Press **MENU** until the display reads INFORMATION MENU.
- 3 Press **ITEM** until the display reads PRINT CONFIGURATION.
- 4 Press **SELECT** to print the configuration page.
- 5 The configuration page shows the printer's current configuration.

Note

An HP JetDirect network configuration page will also print for the networked printers.

Step 13 Connect Printer Cables

For printers equipped with an optional HP JetDirect 600N Print Server, a twisted-pair cable network connection is provided through a 10/100Base-TX (RJ-45) connector. Connection to an Apple LocalTalk network is available through an optional LocalTalk card. The printer also has a port for HP Fast InfraRed Connect.

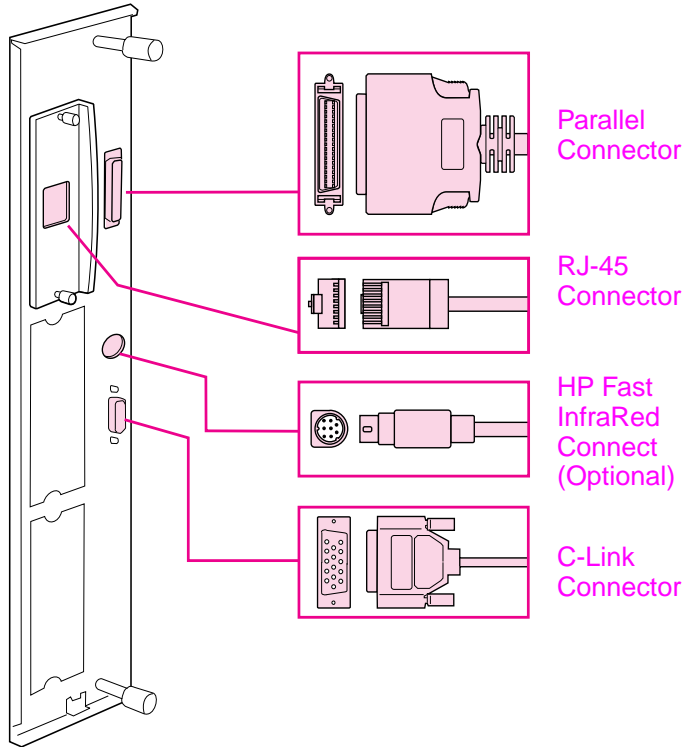

Location of Interface Ports

Connecting Parallel Cable

To ensure reliability, use an IEEE-1284 bi-directional parallel cable. (These cables are clearly marked with "IEEE-1284.") Only IEEE-1284 cables support all of the printer's advanced features.

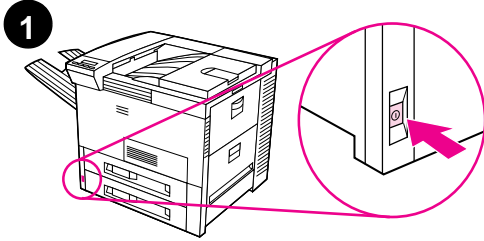

- 1 Make sure the printer and your computer are turned off.

Note

The cable should install easily. If installation is difficult, check the cable orientation.

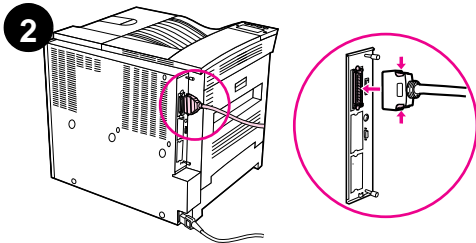

- 2 Connect the parallel cable to the printer parallel port. Press the locking release levers while connecting the cable.

- 3 Connect the other end of the cable to the proper connector on the computer.

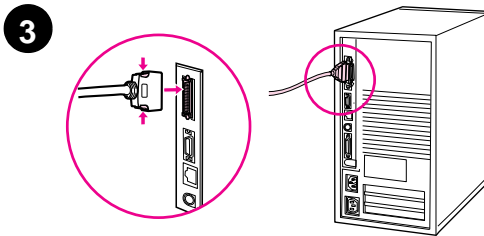

Note

See your online user guide for information on ordering IEEE-1284 parallel cables.

Connecting to Ethernet 10/100Base-TX Network

Use the RJ-45 port to connect the printer to an Ethernet 10/100Base-TX network.

CAUTION

Make sure the printer power is turned off before connecting to the RJ-45 port.

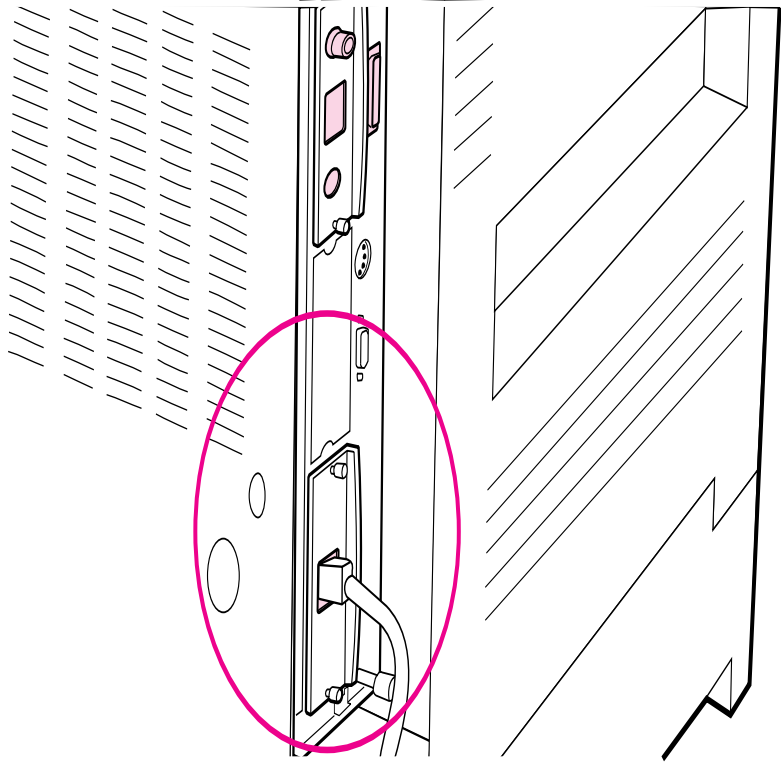

Ethernet 10/100Base-TX Network Interface Cable Connection

- Connect a twisted-pair network cable to the RJ-45 port on the HP JetDirect 600N Print Server.
- Connect the other end of the cable to the network.

Step 14 Install Printing Software

The printer comes with printing software on a compact disc. The printer drivers on this compact disc must be installed to take full advantage of the printer features. If your computer does not have a CD-ROM drive, but you have access to one, you can copy the printing software from the compact disc onto diskettes for installation on your computer.

If you do not have access to a CD-ROM drive, a diskette is provided with the basic printer drivers. (The diskette does not have all of the software available on the compact disc.) The most recent drivers are available on the Internet. Depending on the configuration of Windows-driven computers, the installation program for the printer software automatically checks the computer for Internet access to obtain the latest software.

See the HP Support pages at the front of the printer user guide and the Readme file on the diskette for additional information or to order diskettes if you do not have Internet access.

Installing Windows Printing Software (CD)

For Windows 9x and Windows NT 4.0

- 1 Close all running applications.
- 2 Insert the compact disc into the CD-ROM drive. (Depending on the computer configuration, the installation program may automatically start.)
- 3 Click **Start**.
- 4 Click **Run**.
- 5 Type **D:\SETUP** (or the appropriate drive directory letter) in the command line box and click **OK**.
- 6 Follow the instructions on the computer screen.

For Windows 3.1x and Windows 3.11*

- 1 Close all running applications.
- 2 Insert the compact disc into the CD-ROM drive.
- 3 In the **Windows Program Manager** screen, click the **File** menu.
- 4 Click **Run**.
- 5 Type **D:\SETUP** (or the appropriate drive directory letter) in the command line box and click **OK**.
- 6 Follow the instructions on the computer screen.

Installing Network Software

Note

If the printer is to be used on a network, install and configure the network operating system software on the network administrator's system before individual users install the printing software.

- 1 Select a Custom install to install the printing system software. Be sure to install the HP JetAdmin software.
- 2 Use HP JetAdmin to configure the HP JetDirect print server and the printer for your network. You also can use HP Web JetAdmin to configure your printer with your web browser. For information on using HP Web JetAdmin, see HP's web site at <http://www.hp.com>

* Includes only PostScript Level 2 Emulation (or Level 1 Emulation for Windows 3.1x) and FontSmart.

Installing Macintosh Printing Software

- 1 Quit all open applications.
- 2 Insert the compact disc into the CD-ROM drive.
- 3 Double-click the **Installer** icon and follow the instructions on the screen.
- 4 Open the **Chooser** from the **Apple** menu.
- 5 Click the **Apple LaserWriter** icon. If the icon is not there, contact your Macintosh dealer.
- 6 If you are on a network with multiple zones, select the zone in the **AppleTalk Zones** box where the printer is located. If this is unknown, ask your network administrator.
- 7 Double-click the desired printer. An icon should appear.
- 8 Close the **Chooser** by clicking the Go-Away (Close) box in the upper left corner.

Step 15 Install Online User Guide

This printer comes with a CD-ROM that contains an online user guide. In fact, it contains copies of the user guide translated in many languages. The user guide contains useful information for using the HP LaserJet 8100 series printers, as well as additional troubleshooting and customer support information. This user guide requires Adobe Acrobat Reader 3.0 (or later versions) for viewing. If the system to which the printer is connected already has Adobe Acrobat Reader installed, skip step 1 and go to step 2 of the installation process.

Step 1: Installing Adobe Acrobat Reader

To install Acrobat Reader on Windows 9x/NT 4.0

- 1 Place the CD-ROM that contains the online user guide in the CD-ROM drive.
- 2 Launch Windows Explorer, and open the x:\acrobat\win95_nt folder (where “x” is the letter corresponding with the CD-ROM drive).
- 3 Open the folder for the language version of Acrobat Reader you want to install. The directory contains a single executable file with a .exe extension.
- 4 Double-click the executable file. The application installer appears.
- 5 Follow the instructions in the installer to complete the application installation.

To install Acrobat Reader on Windows 3.x

- 1 Place the CD-ROM that contains the online user guide in the CD-ROM drive.
- 2 Launch File Manager, and click the CD-ROM drive icon.
- 3 Open the acrobat\win3.x directory.
- 4 Open the directory for the language version of Acrobat Reader you want to install. The directory contains a single executable file with a .exe extension.
- 5 Double-click the executable file. The application installer appears.
- 6 Follow the instructions in the installer to complete the application installation.

To install Acrobat Reader on Macintosh

- 1 Place the CD-ROM that contains the online user guide in the CD-ROM drive.
- 2 Double-click the CD-ROM icon.
- 3 Open the Mac folder, then the folder for the language version of Acrobat Reader you want to install.
- 4 Expand the .hqx file and double-click **Reader 3.01 Installer**.
- 5 Follow the instructions in the installer to complete the application installation.
- 6 Once the system restarts, create an alias for Acrobat Reader on the desktop.

Step 2: Installing the User Guide

This procedure copies the files for the user guide onto the system hard disk. To run the user guide from the CD-ROM only, skip this step and go to step 3.

To install the user guide on Windows 9x/NT

- 1 In Windows Explorer, create a folder titled hp8100 in the root directory (typically labeled drive C:).
- 2 Place the CD-ROM that contains the online user guide in the CD-ROM drive.
- 3 In Windows Explorer, select the CD-ROM drive. The content files for each language version appear in the folder.
- 4 Right-click the language version of the user guide you want to install, and select **Copy** from the popup menu.
- 5 Select the x:\hp8100 folder (where "x" is the letter corresponding with the system hard disk).
- 6 Right-click in the right pane of Windows Explorer, and select **Paste** from the popup menu.

To install the user guide on Windows 3.x

- 1 In File Manager, create a folder titled hp8100 in the system root directory (typically labeled drive C:).
- 2 Place the CD-ROM that contains the online user guide in the CD-ROM drive.

- 3 Double-click the CD-ROM drive icon. The content files for each language version appear.
- 4 From the **Windows** menu, select **Tile**.
- 5 In the CD-ROM drive window, click the language version of the user guide you want to install, and drag it to the x:\hp8100 directory.

To install the user guide on Macintosh

- 1 Place the CD-ROM that contains the online user guide in the CD-ROM drive.
- 2 Double-click the CD-ROM icon.
- 3 Copy the language version of the user guide you want to the desktop.

Step 3: Running the User Guide

For Windows users only—The easiest way to access the user guide is to create a shortcut on your desktop (for Windows 9x/NT) or an icon in a program group (in Windows 3.x). You can then launch the user guide by simply double-clicking the shortcut or icon. Refer to the Windows online help for information on these tasks.

To run the user guide on Windows 9x/NT

- 1 From the **Start** menu, select **Adobe Acrobat**, then **Acrobat Reader**. Acrobat Reader launches.
- 2 From the **File** menu, click **Open**.
- 3 Open the directory or drive where the user guide file resides. (For installed files, the path is x:\hp8100\<filename>.pdf, where “x” is the letter corresponding with the system hard disk. For files on the CD-ROM, the path is x:\<filename>.pdf, where “x” is the letter corresponding with the CD-ROM drive.)
- 4 Select the file, and click **OK**.

To run the user guide on Windows 3.x

- 1 In the **Adobe Acrobat** program group, double-click the **Acrobat Reader** icon. Acrobat Reader launches.
- 2 From the **File** menu, click **Open**.
- 3 Open the folder or drive where the user guide file resides. (For installed files, the path is x:\hp8100\<filename>.pdf, where “x” is

the letter corresponding with the system hard disk. For files on the CD-ROM, the path is x:\<filename>.pdf, where “x” is the letter corresponding with the CD-ROM drive.)

- 4 Select the file, and click **OK**.

To run the user guide on Macintosh

- 1 Drag the user guide icon onto the Acrobat Reader icon.

Step 16 Attach Holder for Ready Reference Guide

CAUTION

The Document Holder will be very difficult to remove once it is mounted; therefore, damage to the Document Holder or the mounting surface might occur during removal.

The Document Holder can be mounted on any flat, smooth surface. For example, mount the Document Holder on the exterior of a printer where the Document Holder does not span across two panels and does not obstruct cooling vents, access doors, or installed accessories (including those that might be installed in the future).

- 1 Clean the mounting surface with the alcohol wipe included in the package.
- 2 Once the mounting surface is dry, peel the tape off of the four adhesive strips located on the back of the Document Holder.
- 3 Position the Document Holder so that the open side is on top and the adhesive strips are lightly touching the mounting surface.
- 4 Press firmly on the Document Holder and apply even pressure to all of its corners for at least one minute to give the adhesive time to bond to the mounting surface.
- 5 Insert the printer's Ready Reference Guide into the Document Holder

Step 17 Verify Printer Setup

The easiest way to verify that the installation has been completed successfully is to print a document from a software application.

- 1 Open a software application of your choice and open or create a simple document.
- 2 Make sure the correct printer name appears.
- 3 Print the document.

If the document prints, installation is complete. If nothing prints or if the document does not print correctly, see the problem solving chapter in the printer's online user guide.

Congratulations, the printer setup is complete!



HEWLETT®
PACKARD

Expanding Possibilities

Copyright© 1998
Hewlett-Packard Co.
Printed in USA

Manual Part No.
C4214-90901



Printed on at least
50% Total Recycled Fiber with
at least 10% Post-Consumer Paper



C4214-90901