



The 4043T Impact Crusher is a heavy-duty, tracked horizontal impact crusher plant that effectively crushes rock, concrete and asphalt materials.

The 4043T features a unique curtain relief system that effectively allows the user the ability to crush marginally oversized materials that would normally stop other machines in its size class. This patented method is accomplished by hydraulically lifting the entire crusher lid via hand-held remote control to allow oversized or stacked material to flow into and through the crusher chamber without any stoppage time. This drastically reduces the typical downtime experienced in all other crusher plants.

This feature, combined with only the best named brand components and a massive structural build, make the 4043T the best choice for your crushing needs.



OPERATING DIMENSIONS

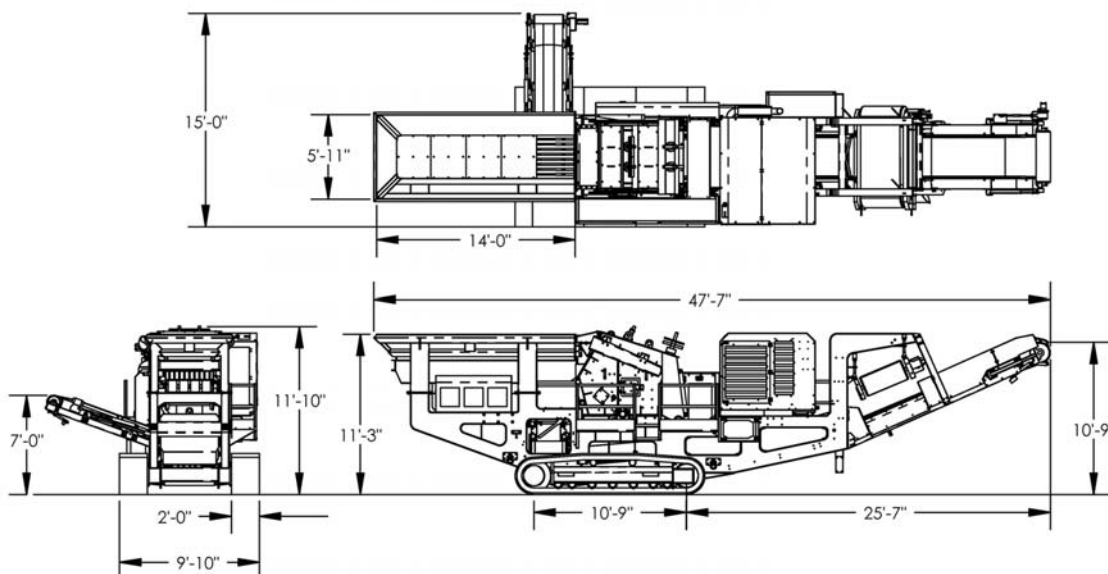

4043T IMPACT CRUSHER

KEY FEATURES

CRUSHER

- 40" x 43" Horizontal Impact Crusher
Years of Proven Engineering and Design Reliability
- Large 43" Wide x 32" High Feed Inlet Opening
- 40" Diameter Rotor with 4 Blow Bars (Two Active)
- Multi-Stage Crushing Utilizing Two Sets of Adjustable Curtains
- Variable Speed Control From 600 RPM to 700 RPM

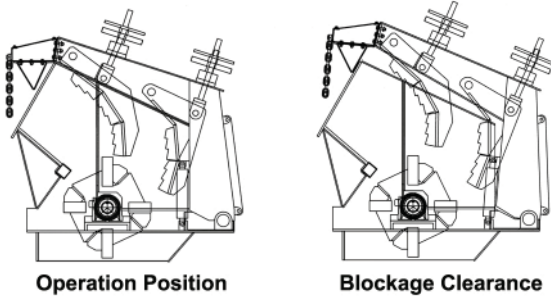

CURTAIN RELIEF SYSTEM

- Raise and Lower of Crusher Lid Curtain
- Curtain Lid Operated by Remote Control
- Hydraulically Raise Crusher Lid Up To 6" During Full Operation To Effectively Clear Bridged or Marginally Oversized Material (Raise from 32" to 38")
- Patents Pending

ENGINE

- Power Supplied By Caterpillar® C-9 ACERT 300 HP Diesel Engine
- Electronic Control of Engine Speed Ranges From 180 to 2200 RPM
- Large Lockable Engine Compartment
Walk-In Compartment Provides Ease of Maintenance on All Service Access Points



HYDRAULIC CLUTCH

- Transfluid® Hydraulic Clutch
Provides Smooth Start-Up and Shut-Down Operations of the Crusher Without Risk of Excessive Rotor Wear
- Designed to Permit Instantaneous Rotor Stoppage
Due to Steel or Other Large Un-Crushable Material Without Consequence

4043T IMPACT CRUSHER

KEY FEATURES

UNDERCARRIAGE

- The 4043T Impact Crusher Uses A Caterpillar® 320 Undercarriage Ensuring Long Term Reliability, Parts Availability and Product Support
- 322 Drive Motors Provide Optimum Grade Climbing Ability Low Speed for Turning and High Speed for Long Distance Travel
- Track Operation Is Controlled From A Safe Distance Wireless Remote Control Handset Used For Movement Operation



FEEDER

- A 40" x 13'-0" Vibratory Grizzly Feeder Features A 14'-0" Long Feed Hopper For Wheel Loader Feeding Vibratory Feeder Includes 1½" Nominal Grizzly Section
- Remote Control Variable Speed Ranges From 600 to 900 RPM
- A Casappa® Drive Motor Is Mounted On The Underside of Feeder Protected From Falling Debris

REMOTE SYSTEM

- Remtron® Wireless Remote Control Operation Including:
 - Variable Feeder Speed
 - Crusher Relief System
 - Track Speed (High and Low)
 - Movement Left, Right, Forward and Backward
 - Emergency Stop



MAGNET

- Reversible Direction
- Fully Adjustable Cross-Belt Permanent Magnet Four Corner Ratchet Adjustment
- Heavy Duty Belt With Armor Plating & Flights For Extended Belt Life
- Stainless Steel Chutes On Both Sides of Conveyor To Prevent Magnetic Material Build-Up

QUALITY COMPONENTS

- The 4043T Impact Crusher Features The Finest Components Components Include: Casappa® Motors, Global® Belting, Precision® Pulleys, Goodman® Idlers, Dodge® Bearings, Dodge® Reducers, American Standard Fittings, Hoses and Fasteners



4043T IMPACT CRUSHER

STANDARD SPECIFICATIONS INCLUDED

POWER SYSTEM

- Caterpillar® C-9 ACERT 300HP Diesel Engine
- 6 Cylinder Water Cooled With Murphy® Shut Downs
- Electronically Controlled Speed 1800-2200 RPM
- Large Lockable Engine Compartment With 3 Sided Access
- Transfluid® Hydraulic Clutch
- 175 Gallon Diesel Fuel Tank
- 125 Gallon Baffled Hydraulic Tank with Oil Cooler

CONVEYORS

- 42" Wide 440 PIW Global® Main Belt
- 10'-9" Main Belt Discharge Height
- Goodman® Guide Idlers For Belt Tracking
- Goodman® Rubber Disc Return Rollers
- Precision® Head Pulley With Dodge® Bearings
- Precision® Wing Type Tail Pulley With Dodge® Bearings
- Dodge® Gear Reducer With Casappa® Drive Motor
- Main Belt Is Directionally Reversible
- Impact Bed Lined With UHMW Plastic Below Crusher
- Impact Bed Lined With UHMW Plastic Below Magnet
- Fines Side Conveyor With 24" Global® Belt
- 7'-0" High Side Conveyor Discharge Height

CONTROLS

- Remtron® Remote Controls For Operation and Movement
- Digital Variable Crusher Speed Controls
- Digital Variable Feeder Speed Controls
- 5 Emergency Stops Control Buttons

OPTIONS

- Spray Bar Dust Control Suppression
- High Chrome Ceramic Blow Bars
- Low Chrome Steel Blow Bars
- Lockable Tool Storage Compartment

UNDERCARRIAGE

- Caterpillar® 320 Tracked Undercarriage
- Upgraded Drive Motors For 322 Tracked Undercarriage

CRUSHER

- 40"x43" Horizontal Impact Crusher
- Large 43"x32" Inlet Feed Opening
- 40" Diameter One Piece Rotor With 4 Blow Bars (2 active)
- Blow Bars Are Reversible Low Chrome Ceramic
- Two Adjustable Curtains
- Remote Curtain Relief System (*patent pending*)

FEEDER

- 40"x13'-0" Vibratory Grizzly Feeder
- Feeder Speed Range 600 - 900RPM
- T-1 Tapered Grizzly Bars with 1½" Nominal Opening
- AR400 Feeder Deck Replaceable Liner Plates
- Grade 80 Hopper Wall Construction
- 14'-0" Long Feed Hopper Opening
- Grizzly/Crusher Bypass Lever For Fines Removal

MAGNET

- Cross Belt Magnet With 4 Corner Ratchet Adjustment
- Armor-Clad Belt With Flights For Maximum Endurance
- Hydraulically Reversible Direction
- Stainless Steel Chutes On Both Sides Of Conveyor

SERVICEABILITY

- Multiple Non-Slip Service Platforms With Ladders
- Key Lock Doors To Service Locations
- Service Manuals In Book Form Or Electronic Format
- Factory Based Parts Availability
- Lifetime Toll-Free Engineering Support
- Split Crusher Housing For Three-Sided Maintenance Access

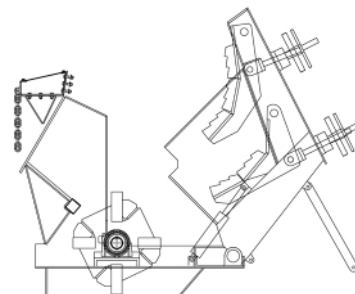

Service Position

The Value of a Caterpillar® 320 Undercarriage

Simply stated...many manufacturers of moving undercarriage components, including link assemblies, rollers, idlers & sprockets, (which represents up to 75% of the cost of the completed lower arrangement) do not have stringent processes in place that yield quality components. Varying hardness levels, material specifications & Manufacturing processes will often produce an inferior component leading to unpredictable wear rates, service points & Ultimately destruction. The result is increased & Unscheduled downtime causing increased operating costs and lower profits. Caterpillar® moving undercarriage components all go through special heat treating processes which provide consistent surface hardness, superior hardened depth & Core hardness levels. The resultant components, be it a link, roller, sprocket or idler, have a distinct metallurgical advantage which yields superior wear resistance, strength & Durability for long term service life. Manhattan Corporation is committed to utilising name brands that deliver maximum performance at the lowest operating cost per hour.

4043T IMPACT CRUSHER

KEY FEATURES

Visit www.manhattancorp.com to see the
4043T IMPACT CRUSHER in action

Manhattan Corporation
Leaders in Mining, Manufacturing and Equipment Solutions

Manhattan Corporation (Pty) Ltd

No 1 Hospital Road, Brakpan North, Johannesburg, South Africa
PO Box 750, Benoni, 1500

Tel +27 11 748 8800

Fax +27 11 748 8898

info@manhattancorp.com

www.manhattancorp.com