

 **PictureMate**
digital frame & photo printer *Show*
cadre photo numérique et imprimante photo



PM 300

Basics

Getting to Know PictureMate

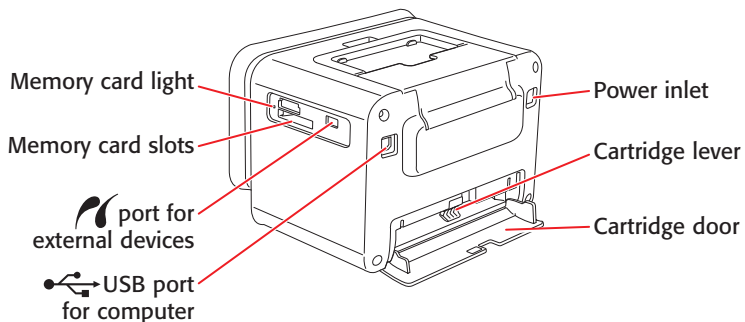
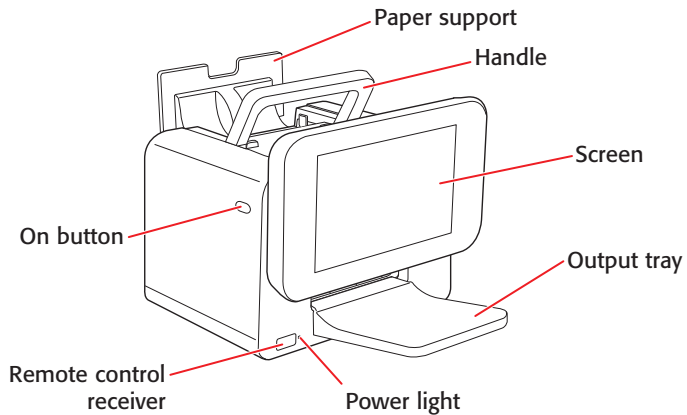

Contents

Welcome!	2
Prepare to View and Print	6
View Photos and Print	10
Do More With Your Photos	16
Print From an External Device	24
Save Photos	28
Print From a Computer	31
Replace Print Pack	37
Take PictureMate With You	41
Set PictureMate Preferences	42
Printer Care and Troubleshooting	45
Notices	55
Index	65

Welcome!

PictureMate Show™ is your easy-to-use, personal photo lab that's also a digital photo frame. Just insert a digital camera memory card and you're ready to view your pictures in a variety of entertaining slideshows or print brilliant, long-lasting photos. Because PictureMate® is light and portable, you can print whenever and wherever you take pictures. Plus, your PictureMate prints will be as brilliant and vibrant generations from now as they are today.

A Quick Introduction to Digital Photography

With film cameras, the process was simple; buy film, take pictures, leave the film at the photo lab, and come back later for your photos and negatives. Since you had negatives, you could take them back later if you wanted reprints.

The digital process is simple too, and it gives you complete control. Just follow the basic steps shown on the right.

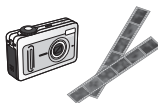

1. Review and Delete

After you finish taking your photos, review them on your digital camera's screen. Delete the photos you don't want.



2. Print

As you view the photos with your family and friends, click the remote control to choose photos and print.



3. Save

To preserve your digital photo files (just like film negatives), save them in PictureMate (or on a thumb drive or your computer) after you print. Then you can reprint them any time.

4. Clear the Memory Card

After you save your photos, use your camera to delete them from your card to make room for more photos.

Special Features

Printing with your PictureMate becomes even easier with these special features:



From PictureMate's screen, you can view your photos and press the **Print** button on the remote control to print the ones you want. Or you can select to print all photos. (See page 10.)

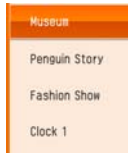

You can select from 12 entertaining slideshows including clock and calendar functions. You can even edit and print your photos on the spot. (See page 13.)

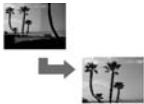

You can crop photos right from PictureMate—no computer required. (See page 16.)



If your camera supports DPOF (Digital Print Order Format), you can select which photos to print while the memory card is still in your camera. When you insert the card into PictureMate, you just have to select **Yes** and press **OK**. (See page 14.)



If you have a PictBridge®-enabled camera, you can connect the camera to PictureMate and control printing right from your camera. (See page 24.)



If you have a Bluetooth®-enabled mobile device or computer, you can send photos wirelessly to PictureMate for printing using the optional Bluetooth Photo Print Adapter. (See page 26.)

Supported Photo Formats

Make sure your photos meet these requirements for viewing and printing with your PictureMate (without a computer):

- JPEG files only
- Resolutions ranging from 80 × 80 to 9200 × 9200 pixels

PictureMate recognizes and prints up to 9,999 photos on your memory card.

Where to Find Information



See your *Start Here* sheet to unpack, set up, and use your PictureMate.



Basics explains how to view and print photos directly from your memory card and other devices, replace the Print Pack, and solve problems.



The online *User's Guide* has detailed instructions for using PictureMate. A shortcut to the *User's Guide* is installed from the CD.

Where to Get a Print Pack and Accessories



The PictureMate Print Pack has everything you need to print in one box: photo paper and a photo cartridge.

You can buy a Print Pack wherever PictureMate is sold or from retailers that sell printer supplies.

The following Print Packs are available:

Print Pack contents	Part number	Supported PictureMate models
Glossy photo paper (150 sheets) and photo cartridge	T5846	All PictureMate 200/300 Series models
Matte photo paper (100 sheets) and photo cartridge	T5845-M	

You can also buy a Print Pack and other PictureMate accessories from an Epson authorized reseller. To find the nearest reseller, call 800-GO-EPSON (800-463-7766). Or you can purchase online at www.epsonstore.com (U.S. sales) or www.epson.ca (Canadian sales).

PictureMate Remote Control Buttons

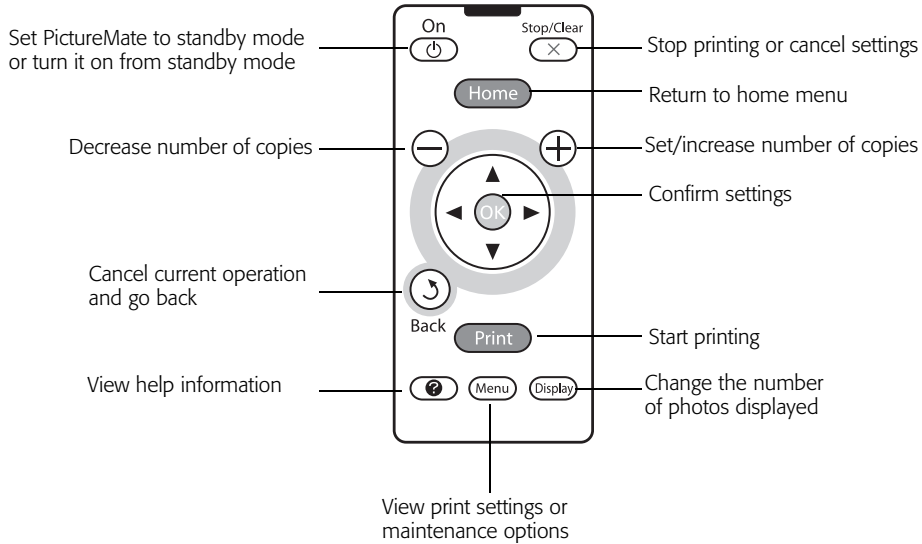

Prepare to View and Print

Before you view and print with PictureMate, you need to:

- Insert your memory card (below)
- Load paper (see page 8)

When you're finished, you can remove your memory card (see page 8).

Inserting Your Memory Card

- 1 Press the top of the screen to slide it up.

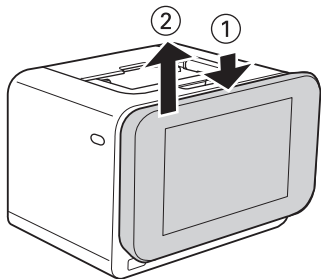

- 2 Press the **On** button to turn on PictureMate.

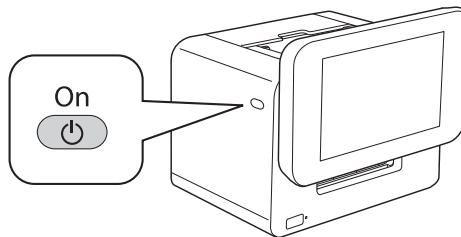

- 3 Insert the memory card into the correct slot, as shown on the following page. Insert just one card at a time.

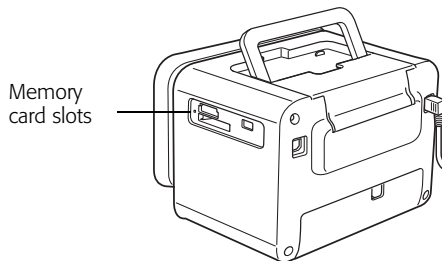

Note: PictureMate can't read multiple cards at once.

- 4 Push the card in carefully until it stops (it won't go in all the way).**

When the card is in, the memory card light comes on and begins to flash.

Caution: Do not remove a card while the memory card light is flashing; you may lose photos on your card.

Top slot:

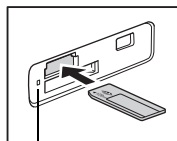

Memory card light

SD™ (Secure Digital) and SDHC™ (High Capacity)
miniSD™* and miniSDHC*
microSD* and microSDHC*
Sony Memory Stick®**
Memory Stick Duo™*
Memory Stick Micro*
Memory Stick PRO™
Memory Stick PRO Duo™*
Memory Stick PRO-HG Duo™*
MagicGate™ Memory Stick**
MagicGate Memory Stick Duo™*

Bottom slot:

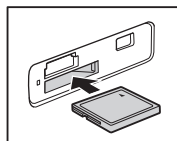

Microdrive™
CompactFlash® (Type I and II)

* Requires adapter
** Maximum capacity 128MB

Now you are ready to view your photos and start printing. (See page 10.)

Removing Your Memory Card

When you are ready to remove a memory card, first make sure the memory card light is not flashing.

Caution: Do not remove a card while the memory card light is flashing; you may lose photos on your card.

Pull the card out of the slot.

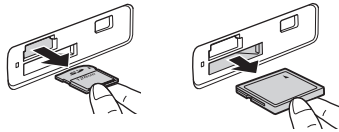

Loading Paper

Caution: Don't load plain paper; this may damage PictureMate.

1 Open the paper support.

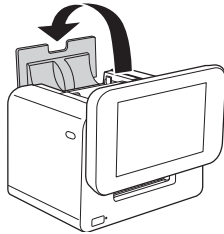

2 Slide out the edge guides.

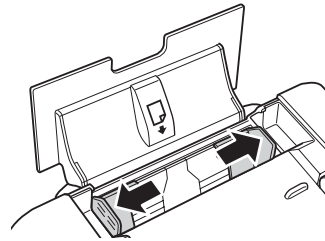

3 Create a stack of up to 20 sheets of paper and separate the sheets slightly by fanning them.

4 Place your paper into the slot between the edge guides with the glossy or whiter side up. Slide the edge guides inward slightly.

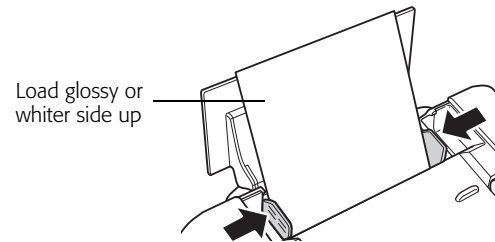

Note: Load a maximum of 20 sheets at a time. Load your paper glossy side up to prevent smearing.

- 5 Store any unused paper in the original package and keep it flat in a dry area to prevent curling.**

Note: When you need more paper, order a PictureMate Print Pack. See page 37 for more information.

- 6 Attach the output tray.**

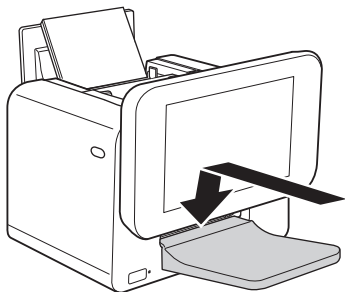



Using the On Button

You can use the  **On** button on the remote control to place PictureMate in standby mode and save energy.

- 1 Press the  **On** button on the side of PictureMate to turn it on. The power light turns green.**

Note: If you are not using PictureMate, a slideshow of your photos begins automatically after 3 minutes. Press any button to return to the function you were using.

- 2 When you're finished using PictureMate, press the  **On** button on the remote control. The power light turns orange.**
- 3 Press the  **On** button on the remote control or on the side of the printer to return PictureMate to full operation.**

Note: To turn PictureMate off completely, use the  **On** button on the side of the printer.

View Photos and Print

After you insert your camera's memory card, you can print your photos or view them in a variety of entertaining slide shows.



Make sure you adjust the angle of the screen for comfortable viewing.

You can view your photos and choose from the following options for printing them:

- Print individual photos on your card (on the right)
- Print all the photos on your card (see page 12)
- Print from a slideshow (see page 13)
- Print photos pre-selected in your camera (see page 14)

If you are not using PictureMate, a slideshow of your photos begins automatically after 3 minutes. Press any button to return to the function you were using.

To store and display your printed photos, see page 15.

If you need help at any time, press the  button on the remote control. You see instructions on whatever PictureMate function you were using. Press  for more

information, or select **Contents** for a list of topics. See page 45 for details about the help system.

Printing Individual Photos

PictureMate's 7-inch screen makes it easy to select the photos you want to print. Make sure your memory card is inserted as described on page 6.

- 1 From the home menu, select **PRINT PHOTOS** and press **OK** on the remote control.



- 2** Select **View and Print Photos** and press **OK**. Your photos are displayed by date:



Note: If your memory card has more than 1000 photos, PictureMate divides them into groups of 999. You can select the group you want to view and print.

- 3** Press **▲** or **▼** to select different dates. Press **◀** or **▶** to move through your photos.

Note: If you want to see your photos one at a time, press the **Display** button. Press the button again to switch between 20 photos, one photo, and display by month.

- 4** When you see a photo you want to print, press **⊕** to select it.

You see the number 1 on the photo, indicating that one copy will be printed.

Note: If you want to crop or edit your photo, press **OK**. See page 16 for instructions.

- 5** To print more than one copy, press **⊕** to increase the number of copies or **⊖** to decrease it.
- 6** After you have selected all the photos you want, press **Print**.
- 7** You see a preview screen showing the number of sheets required and other settings, for example:

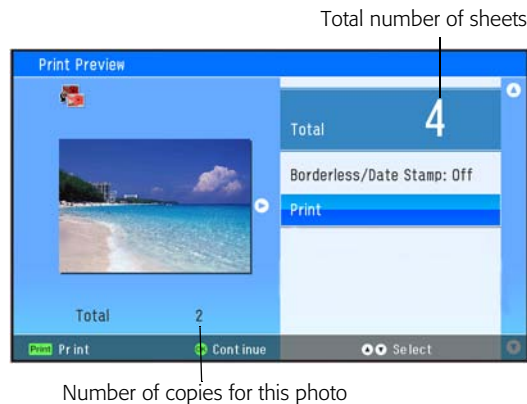

- 8 Press ◀ or ▶ to review your selected photos.
- 9 If you want to print with a white border or include the date, select **Borderless/Date Stamp: Off** and press **OK**. Then select the option you want and press **OK** again.

Note: The date comes from your camera, not from the printer. If this information is incorrect, adjust the date setting on your camera.

- 10 Make sure you have enough paper loaded, then press **Print** to start printing.

If you need to cancel printing, press (X) **Stop/Clear**

After printing, you see a message asking if you want to save the printed photos to the print history.

- 11 Select **Yes** and press **OK** to save the pictures on PictureMate's hard drive.

Whenever PictureMate does not have a memory card (or thumb drive) inserted, it will display a slideshow of the saved photos.

You can also select the saved photos for printing at any time. See page 22 for instructions.

Printing All Photos

You can print photos at full size or on a proof sheet of small thumbnail images.

- 1 From the home menu, select **PRINT PHOTOS** and press **OK** on the remote control.
- 2 Select **Print All Photos** and press **OK**.

You see a screen like the following, showing the number of photos to be printed:



- 3 If you want more than one copy of each picture, press ⊕ to increase the number of copies or ⊖ to decrease it.

- 4 Select **1 Per Page** or **Proof Sheet** (20 per page) and press **OK**.

If you selected 1 Per Page, you can press ◀ or ▶ to review your photos.

- 5 If you selected 1 Per Page and you want to print with a white border or include the date, select **Borderless/Date Stamp: Off** and press **OK**. Then select the option you want and press **OK** again.

Note: If you want to change the layout or edit your photos, press **Menu**. See page 16 for instructions.

- 6 Make sure you have enough paper loaded, then press **Print** to start printing.

Note: If you are printing more than 20 pages, you will need to reload paper while printing. Load a maximum of 20 sheets at a time. When you see a message that paper is out, load more paper and press **OK** to continue printing. If you need to cancel printing, press (X) **Stop/Clear**.

After printing, you see a message asking if you want to save the printed photos to the print history.

- 7 Follow the instructions on the screen to save the photos. See page 12 for more information.

Printing From a Slideshow

You can select from 12 slideshows with 3D animation, and choose photos for printing right from the show.

- 1 From the Home menu, select **SLIDE SHOW** and press **OK** on the remote control.



- 2 Select the slideshow you want, then press **OK**.

PictureMate displays your photos as a slideshow with a variety of animation effects.

When you see the “countdown” in the upper right corner of the screen, you can select a photo for printing.

- 3 Press **OK** to select the photo(s) you want to print. Those you select are “reserved” for printing.

When the slideshow is finished, you see the print confirmation screen.

- 4 Press ◀ or ▶ to review your reserved photos.
- 5 If you want to print with a white border or include the date, select **Borderless/Date Stamp: Off** and press **OK**. Then select the option you want and press **OK** again.
- 6 Make sure you have enough paper loaded, then press **Print** to start printing.

If you need to cancel printing, press (X) **Stop/Clear**

After printing, you see a message asking if you want to save the printed photos to the print history.

- 7 Follow the instructions on the screen to save the photos. See page 12 for more information.

Note: To stop the slideshow at any time, press ↵ **Back** or

(X) **Stop/Clear**.

Printing Camera-Selected DPOF Photos

If your camera supports DPOF (Digital Print Order Format), you can use it to pre-select which photos and how many copies you want to print.

See your camera’s manual to choose photos for printing with DPOF, then insert your memory card in PictureMate.

PictureMate automatically reads your pre-selected photos and displays this message:

Photos were pre-selected to print with your camera. Do you want to print these Photos?

- 1 Select **Yes** and press **OK**.
- 2 If you want to print with a white border or include the date, select **Borderless/Date Stamp: Off** and press **OK**. Then select the option you want and press **OK** again.
- 3 If you want to change any print settings, press **Menu**. See page 16 for instructions.
- 4 Make sure you have enough paper loaded, then press **Print**.

Storing and Displaying Your PictureMate Photos

Photos printed on PictureMate photo paper are beautiful and long-lasting. Follow these guidelines to make sure they will look great for generations.

Caring for Your Photos

- To avoid scratches or smudging, do not rub the printed side of the photo.
- To prevent smudging, avoid stacking your photos until they are completely dry.
- Let photos sit for 24 hours before framing.
- After you print, the colors on your photos will take some time to set as the ink dries. During this time, the colors may look different than you expect.

Displaying Your Photos

- To ensure photos will last as long as possible, display them under glass or in photo albums.
- Keep photos out of the sun to help prevent fading.

Storing Unused Paper

Return unused paper to the original package. Store paper flat to prevent curling, and keep it away from extreme temperatures, high humidity, and bright light.

Do More With Your Photos

You can select a variety of layouts and crop your photos for printing individually or in multi-photo formats.

You can also do the following:

- Remove red eyes from your photos (see page 19)
- Fix color and photo quality (see page 20)
- Print in black-and-white or sepia (see page 20)
- Adjust the amount of expansion and cropping for borderless printing (see page 21)
- Select the source for displaying and printing photos (see page 22)
- Print text from your camera (see page 22)
- Rotate your photos on the screen (see page 23)

Note: The features described in this section do not change or replace the original digital photo file; they customize only the print(s) you make at that time.

If you need help at any time, press the  button on the remote control for a list of topics. See page 45 for details about the help system.

Zooming and Cropping

You can print just part of a photo, cropping out the area that you don't want. The part you keep is automatically enlarged to fit the layout.

Cropping affects only your printed photo, not your original image.

- 1 Select the photo you want to print and press **OK**.



- 2 Select **Crop** and press **OK**.



- Press **+** to zoom in or **-** to zoom out. You can zoom up to 500%.
- Press **←**, **→**, **▲**, or **▼** to move the view to a different part of your photo.
- Press **Display** to rotate your photo.

- 3 Press **OK** when you're finished cropping.

Note: Depending on the size of the image, the preview may take longer to display after cropping.

Choosing a Layout

By default, your photos are printed at the full 4 × 6 size. If you want to place several small photos on one page, you can use the Layout menu.

- 1 From the Home menu, select **LAYOUT** and press **OK** on the remote control.

- 2 Select **Layout Options** and press **OK**.

Note: If you want multiple copies of the same photo, select **Crop/Trim Photo(s)**. See page 18 for details.

- 3 Choose one of the methods for selecting the photos, then press **OK**.
- 4 Use the arrow buttons to select the photo(s) you want to print—all photos, or all in a selected month or on a selected date.
- 5 Select **Wallet** and press **OK**.
- 6 Select the layout you want, then press **OK**. You have these choices:

- **Wallet** (2 per page)
- **4 per page**
- **Mini-wallet** (8 per page)
- **16 per page**

- 7 Press **OK** to preview your layout. Note the large number, which tells you how many sheets of paper are required.
- 8 If you want to adjust any settings, press **Menu**. See page 20 for more information.
- 9 Press **OK** or **Print** to start printing.

Custom Sizing and Cropping

You can set custom sizes and crop your photos. Depending on the size of the photo(s), multiple copies may fit on one page. Cropping affects only your printed photo, not your original image.

- 1 From the Home menu, select **LAYOUT** and press **OK** on the remote control.
- 2 Select **Crop/Trim Photo(s)** and press **OK**. You see your photos displayed by date.

Note: If you want to see your photos one at a time press the **Display** button. Continue pressing the button to switch between 20 photos, one photo, and display by month.

- 3 Select the photo you want to print and press **OK**.

You see a screen that allows you to adjust the printed size of your photo. The size you select determines the number of copies that will fit on a page—from one to 12 copies.

Maximum size in inches	Number of copies
1.2 × 1.4	12
1.8 × 1.4	8
1.8 × 1.8	6
1.8 × 2.8	4
3.7 × 2.8	2

- 4 Select the width and height dimensions, then select **Finished** and press **OK**.
- 5 Set the area you want to print, then press **OK**.
 - Press \oplus to zoom in or \ominus to zoom out.
 - Press \blacktriangleleft , \blacktriangleright , \blacktriangleup , or \blacktriangledown to move the view to a different part of your photo.
 - Press **Display** to rotate your photo.

After you finish cropping and press **OK**, you see a screen like the following, showing your cropped photo and the layout:



- 6 Adjust the number of copies if necessary, then press **OK**.
- 7 Select any of the enhancement settings shown on the screen, or press **Menu** for additional settings. See page 20 for more information.
- 8 When you're ready, press **Print**.

Fixing Red-Eye

PictureMate can fix red eyes in your photos when you print.

Note: PictureMate may not be able to correct red eyes in all photos, and printing will be slower when you use this feature.

- 1 Select a photo with the red-eye problem and press **OK**.



- 2 Select **Fix Red-Eye** and press **OK**.
- 3 Select **On** and press **OK**.

When you are ready to print, you see the Fix Red-Eye icon on the preview screen.

Adjusting Photo Settings

PictureMate lets you adjust the color and improve the quality of your photos without using a computer. You can do the following:

- Enhance your photos based on the following types of scene detection: standard, people, landscape, or night scene
- Print at the highest resolution
- Adjust the sharpness
- Print your pictures in black and white or sepia

Note: These settings affect only your printed pictures. They do not change your original image files. The settings you select are applied to all your photos.

- 1 Press the **Menu** button on the remote control.
- 2 Select **Adjust Photo Settings** and press **OK**.

You see this screen:

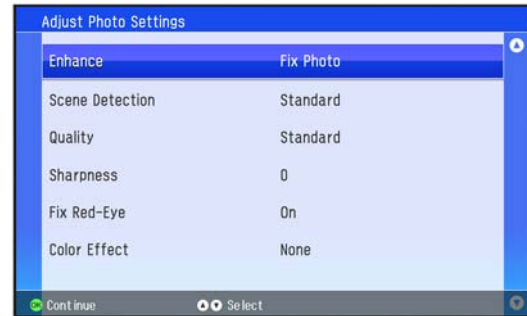

- 3 Select from the following options and settings:

Enhance—You can select from the following enhancement methods:

- **Fix Photo:** This setting (selected by default) improves your photos' colors and increases contrast and sharpness. It may correct images that are too dark, too bright, or backlit.
- **P.I.M.:** If your camera supports PRINT Image Matching® (P.I.M.) or Exif Print, this setting helps ensure an accurate image reproduction.

- **None:** Prints photos as is or bypasses P.I.M. or Exif Print data. Select this setting for the fastest printing.

Scene Detection—If **Fix Photo** is selected as the **Enhance** setting, you can choose from the following: **Standard**, **People**, **Landscape**, **Night Scene**. If you are printing a variety of photos, select **Standard**.

Quality—Select **Standard** or **Best**. Printing is slower at Best quality.

Sharpness—Increase or decrease the sharpness until you are happy with the effect (as shown on the sample photo).

Fix Red Eye—See page 19 for details.

Color Effect—Select **Black & White** or **Sepia** (like an old-fashioned brown-tone photo). You can see the effect on the sample photo. (You can also select this setting on the print confirmation screen.)

- 4 Press **OK** to apply the selected setting.

Note: The settings you select apply to all photos you print.

When you press **Print**, you see the settings applied to your photos on the preview screen.

Adjusting Borderless Expansion

When you print borderless pictures, your images are automatically expanded and cropped.

If your pictures are cut off around the edges, you can adjust the amount of expansion and cropping.

- 1 Press the **Menu** button on the remote control.
- 2 Select **Setup** and press **OK**.
- 3 Select **Expansion** and press **OK**. You can select **Maximum**, **Middle**, or **Minimum**.
- 4 Select **Minimum** to reduce the amount of expansion. Then press **OK**. Read the warning message and press **OK**.

If you see white lines on the edges of your photos after printing with the **Minimum** setting, repeat steps 1 to 3 and select **Middle** or **Maximum**.

Note: The setting you select applies to all photos you print.

Selecting the Source for Photos

When you have photos saved in print history, you can choose between those and the photos on your memory card. If you insert a thumb drive or other device, you can also select it as a source, and select from multiple folders.

- 1 Press the **Menu** button on the remote control.

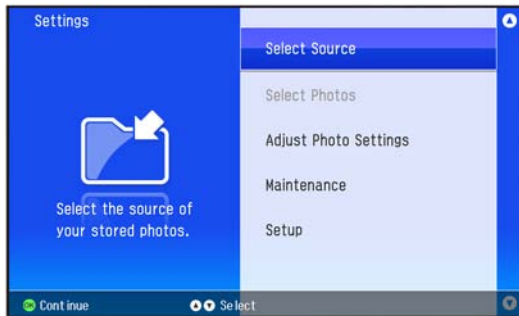

- 2 Press **OK** again to choose **Select Source**.
- 3 Press **OK** to choose **Change Source**.
- 4 Select the source you want and press **OK**.

Note: If you choose an external device that has more than one folder, you can also select an individual folder or **All folders**.

Adding Camera Text

If your camera allows you to add text to your photos, you can print the pictures along with the text.

This setting is available for borderless photos only.

- 1 Select the photos that have text added by your camera.
- 2 Press the **Menu** button on the remote control.
- 3 Select **Setup** and press **OK**.
- 4 Select **Camera Text** and press **OK**.
- 5 Select **On** and press **OK**.

When you press **Print**, you see a small camera text icon on the preview to remind you about the setting.

Note: Before you print, make sure the Borderless Layout setting is selected. See page 12 for more information.

Rotating

You can rotate a photo on PictureMate's screen. This does not affect how the photo prints, only how it displays.

- 1** Select the photo you want to rotate and press **OK**.
- 2** Select **Rotate** and press **OK**.

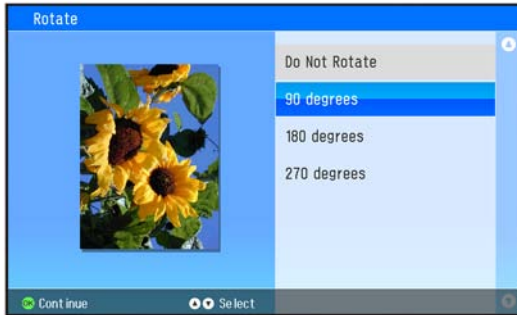

- 3** Select **90 degrees**, **180 degrees**, or **270 degrees** (or select **Do Not Rotate**). Your photo is rotated on the screen.
- 4** Press **OK**.

Print From an External Device

PictureMate can print photos stored on a:

- PictBridge-enabled digital camera (this page)
- USB-connected external drive, such as a thumb drive (see page 25)
- Bluetooth-enabled device (requires an optional Bluetooth Photo Print adapter; see page 26)

Tip: Once you've connected PictureMate to an external drive, you can back up photos from your camera's memory card to the drive for safekeeping. See page 28 for instructions.

Printing From a Digital Camera

You can connect a digital camera that supports PictBridge printing to PictureMate and use the camera to control printing.

Check your camera manual to see if it supports PictBridge. A cable may not be included with your camera.

- 1** Make sure PictureMate is on but not printing.
- 2** Make sure there are no memory cards in PictureMate's slots.

Note: You must remove your memory card or the printer will read photos from the card, not from a camera.

- 3** Turn on your camera.

- 4** Connect your camera's USB cable to your camera and the  port on the side of PictureMate.

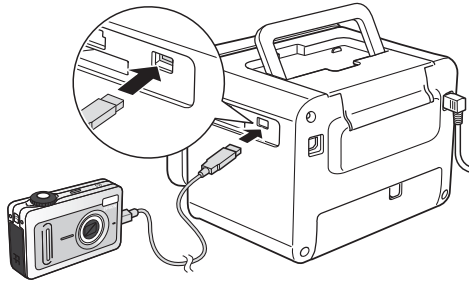

- 5** Use your camera's controls to select and print photos on PictureMate. (See your camera manual for instructions.)

When you print directly from your camera, you can't select settings the way you can when you print from a memory card. Instead, you can use the PictBridge Settings on the Setup Menu. For more information, see your online *User's Guide*.

Printing From an External Drive

If you have saved photos on a thumb drive, you can connect the drive to the side of PictureMate and print just like you do when you insert a memory card.

You can also connect and print from an external CD drive or hard drive.

Note: Epson cannot guarantee the compatibility of any drives.

- 1** Make sure PictureMate is on.
- 2** If PictureMate is connected to a computer, disconnect it or turn off the computer.
- 3** Connect your drive to the  port on the side of PictureMate.

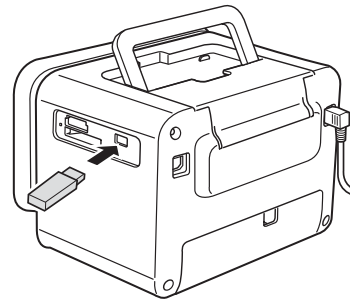

If you have a memory card already inserted in PictureMate, you see a message asking if you want to display photos from the device

- 4 Select **Yes** and press **OK**.
- 5 If necessary, select **All Folders** or a specific folder on the drive and press **OK**.

Once your photos are displayed, you can view and print them just like photos on a memory card.

Printing Wirelessly From a Bluetooth Device



You can print photos wirelessly from your Bluetooth-enabled mobile device or computer when you use the optional Bluetooth Photo Print Adapter. The adapter (part# C12C824383) is available from your local reseller or Epson (see page 54).

Note: Although PictureMate complies with the Bluetooth specification, it is not guaranteed to work with all devices that have Bluetooth wireless technology. Make sure your photos meet the requirements listed on page 4.

- 1 Make sure PictureMate is on but not printing.

Caution: Do not connect or remove the Bluetooth Photo Print Adapter while it is communicating with a device or while PictureMate is printing; this may cause PictureMate to malfunction.

- 2 Plug the adapter into the  port on the side of PictureMate.

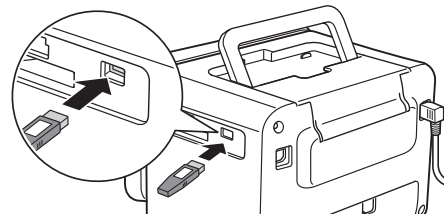

- 3 Make sure you are within about 30 feet of PictureMate.
- 4 Select the photo you want to print from your Bluetooth device and send it to PictureMate:
 - **Windows®**: Send photos directly to PictureMate with your Bluetooth file sharing program. See the documentation included with your Bluetooth adapter for details.

- **Macintosh®:** Double-click **Bluetooth File Exchange** in your **Utilities** folder. Follow the on-screen instructions.
- **Mobile devices:** See your product's documentation for instructions on setting up Bluetooth file sharing and sending files.

If you see a Bluetooth error message on the PictureMate screen, try printing the photo from a memory card or your computer instead.

Note: For instructions on selecting PictureMate's Bluetooth settings, see the online *User's Guide*.

Disconnecting the Adapter

Make sure PictureMate is not printing, then pull the adapter out of its port.

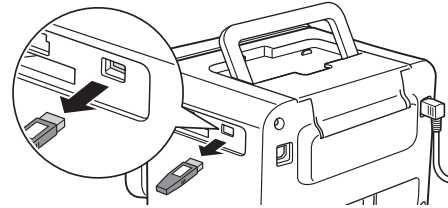

Caution: Do not connect or disconnect the Bluetooth Photo Print Adapter while it is communicating with your device or while PictureMate is printing; this may cause PictureMate to malfunction.

Save Photos

After you print, PictureMate asks if you want to save the photos on your camera's memory card to the print history. If you select **Yes**, the photos are saved on PictureMate's internal hard drive.

If you want to change the way photos are saved, see page 42.

Note: PictureMate saves only the photos printed from a memory card, not from a camera or thumb drive.

You can also back up all the photos on your memory card to a thumb drive or other external storage device.

If you later decide to delete some of the photos from PictureMate, you can select specific photos or delete all photos.

Backing up Photos

Before you start, make sure PictureMate is not connected to your computer.

- 1 Insert your memory card into PictureMate.
- 2 Insert a USB storage device or thumb drive into the  port on the side of PictureMate. If you need instructions, see page 25.
- 3 From the Home menu, select **Photo Storage**.

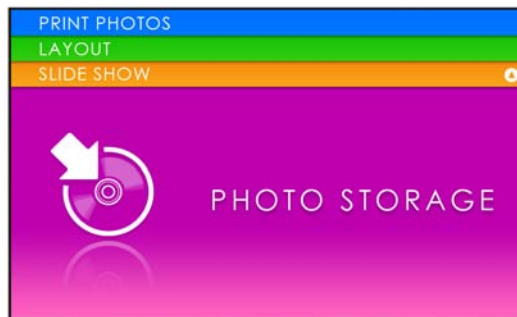

- 4 Press **OK**.
- 5 Select **Save All Photos**.

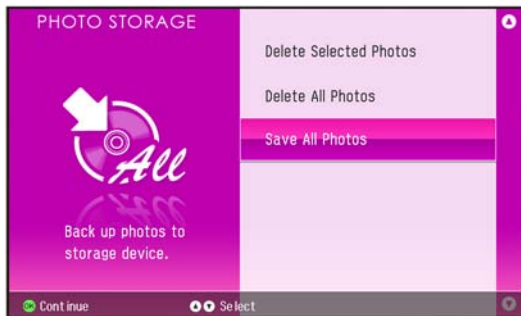

- 6 Press **OK**, then read the message and press **OK** again.
- 7 Follow the instructions on the screen to complete the backup.

If you need to cancel the backup, press **⊗ Stop/Clear**.

Caution: Avoid handling the printer during backup. Also, do not remove the memory card while photos are being saved, or you may lose photos on your card.

Deleting Photos from Print History

You can select photos to delete from PictureMate's print history, or delete all the photos.

Note: You can delete photos from the print history only, not from a memory card.

- 1 From the Home menu, select **Photo Storage**.
- 2 Select **Delete Selected Photos** or **Delete All Photos**.
 - If you choose to delete all photos, skip to step 6.
 - If you choose to delete selected photos, you see a selection screen like the following:

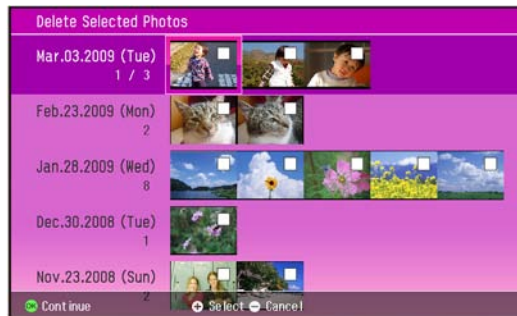

- 3 Press ▲ or ▼ to select different dates. Press ◀ or ▶ to move through your photos.

Note: If you want to see your photos one at a time press the **Display** button. Continue pressing the button to switch between 20 photos, one photo, and display by month.

- 4 When you see a photo you want to delete, press ⊕ to select it.

You see a red check mark on the photo, indicating that it will be deleted.

- 5 After you have selected all the photos you want to delete, press **OK**.
- 6 When you see the confirmation screen, select **Yes** and press **OK**. The photo(s) are cleared from the print history.
- 7 Press **OK** to continue.

Print From a Computer

To use PictureMate with your computer, you must first:

- Install the PictureMate software on your computer from the PictureMate CD as described here.
- Connect PictureMate to your computer with a USB cable. If you don't have a USB cable, you can buy one from your local computer dealer or from Epson.



Once your software is installed and PictureMate is connected to your computer, see your online *User's Guide* for instructions on printing from your computer.

Tip: Once you've connected PictureMate to your computer, you can insert a memory card in PictureMate and view, copy, or print files on the memory card as if it were a drive on your computer. You can even copy files from your computer to the memory card. See your online *User's Guide* for instructions.

Note: Periodically, it's a good idea to check Epson's support website at epson.com/support for free updates to your PictureMate printer software. Download instructions are posted for your convenience.

Installing Software and Connecting PictureMate

DO NOT connect PictureMate to your computer before installing the software. **REMOVE** your memory card from PictureMate before you begin.

Follow the installation steps for your computer:

- Windows (page 31)
- Macintosh (page 34)

Note: If you have problems installing the software, see page 51.

Installing Software for Windows

Before you start, make sure PictureMate is **NOT** connected to your computer and does **NOT** have a memory card inserted in it.

- 1 Press the  **On** button to turn on PictureMate.

Note: If you see a Found New Hardware screen, click **Cancel** and disconnect PictureMate from your computer.



2 Insert the PictureMate CD.

With Windows 8, Windows 7, and Windows Vista, if you see the AutoPlay window, click **Run Setup.exe**. When you see the User Account Control screen, click **Continue**.

3 When you see this screen, click **Install**.



4 Read the license agreement and click **Accept**. The software starts installing.

After a moment, you see this screen:



- 5 Connect the USB cable to any open USB port on your computer. Then connect the other end to the  USB port on the back of PictureMate.

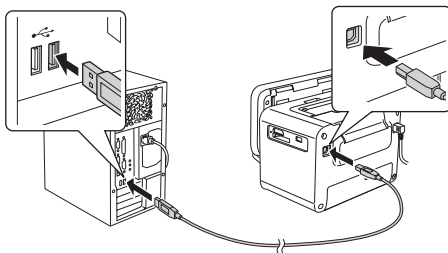

Your PictureMate software is installed.

Note: If you see a screen like this one, remove your memory card and click the **X** in the corner to close it.



Note: PictureMate is automatically set as your default printer. If you have another printer, you can change this setting in the Windows Control Panel.

- 6 Follow the on-screen instructions to install the rest of the software.
- 7 When you see a message that installation is complete, click **Exit**.

- 8 Follow the on-screen instructions to register your PictureMate.
- 9 When you're done, remove the CD.

Now you can print photos from your computer on PictureMate (see your online *User's Guide*).

Installing Software for Macintosh

Before you start, make sure PictureMate is **NOT** connected to your Macintosh and does **NOT** have a memory card inserted in it.

- 1 Press the  **On** button to turn on PictureMate.
- 2 Insert the PictureMate CD.
- 3 Double-click the **Epson** icon.

- 4 When you see this screen, click **Install**.



- 5 Read the license agreement and click **Accept**.
- 6 Follow the on-screen instructions to install the software.

After a few minutes, you see this screen:



- 7 Connect the USB cable to any open USB port on your Macintosh. Then connect the other end to the  USB port on the back of PictureMate.

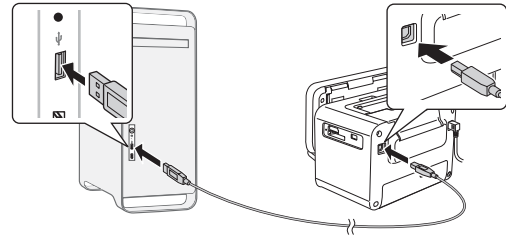

If you're using Mac OS X 10.5.x or later, skip to step 10.

If you're using Mac OS X 10.3.9 or 10.4.11, continue with the next step.

8 When you see this screen, click **Add Printer**.

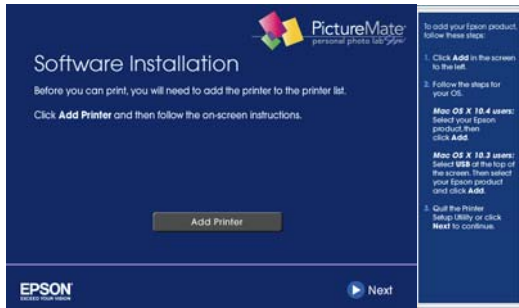

9 Follow the steps on the right side of the screen to add PictureMate.

10 Follow the on-screen instructions to install the rest of the software and register your PictureMate.

11 When you're done, eject the CD.

Now you can print photos from your Macintosh on PictureMate (see your online *User's Guide*).

Replace Print Pack

When PictureMate needs a new Print Pack, you will see a message on the screen. The Print Pack contains a new photo cartridge and photo paper.

When you need a new Print Pack, see these sections:

- Buy a PictureMate Print Pack (to the right)
- Replace the photo cartridge (see page 38)

If you want to check the status of your photo cartridge, see page 40.

Tip: If you see a replacement message while printing, you can replace the photo cartridge and continue the current print job. Just replace it without turning off and unplugging PictureMate.

Note: Use your photo cartridge within six months of installing it and before the expiration date on the package.

Caution: To ensure good results, use a genuine PictureMate photo cartridge and do not refill it. Other products may cause ink spills or other damage to your printer not covered by Epson's warranty.

Buying a Print Pack



You can buy a PictureMate Print Pack wherever PictureMate is sold or from retailers that sell printer supplies.

The following Print Packs are available:

Print Pack contents	Part number	Supported PictureMate models
Glossy photo paper (150 sheets) and photo cartridge	T5846	All PictureMate 200/300 series models
Matte photo paper (100 sheets) and photo cartridge	T5845-M	

You can also buy a Print Pack and other PictureMate accessories from an Epson authorized reseller. To find the nearest reseller, call 800-GO-EPSON (800-463-7766). Or you can purchase online at www.epsonstore.com (U.S. sales) or www.epson.ca (Canadian sales).

Replacing the Photo Cartridge

Make sure you have a new PictureMate Print Pack before you remove the old photo cartridge. Once you remove the cartridge, you must install the new one right away.

Caution: Before you replace the cartridge, read the "Photo Cartridge Safety Instructions" on page 57.

- 1** Make sure PictureMate is on but not printing.
- 2** Open the cartridge door on the back of PictureMate.

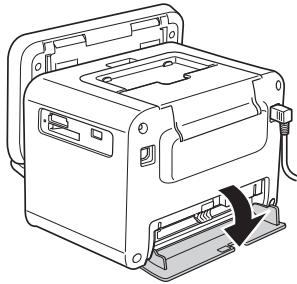

- 3** Slide the cartridge lever left, to the **Release** position.

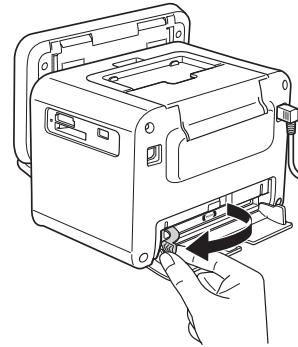

Caution: Do not try to pull out the cartridge without moving the lever.

- 4** Pull out the cartridge and dispose of it properly. (For appropriate disposal, check local resources for recycling guidelines.)

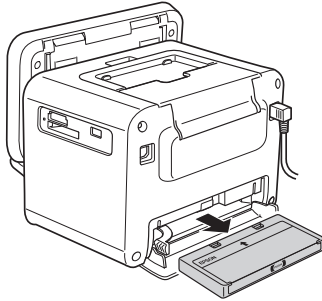

Warning: Keep photo cartridges out of the reach of children and do not drink the ink.

If ink gets on your hands, wash them thoroughly with soap and water. If ink gets in your eyes, flush them thoroughly with water. If discomfort or vision problems continue after flushing, see a doctor immediately.

- 5** Remove the new photo cartridge from its package.

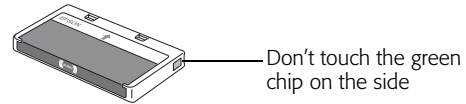

Caution: Don't touch the small green circuit board. Install the photo cartridge immediately. If you leave a cartridge unpacked for a long time before using it, normal printing may not be possible.

- 6** Slide the cartridge straight into the slot, label side up, until it clicks into place.

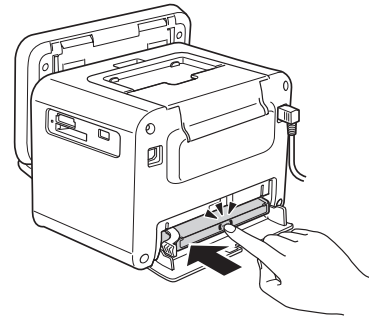

Note: The cartridge won't go in all the way. You need to use the cartridge lever to lock it in place.

- 7** Slide the lever right, to the **Lock** position.

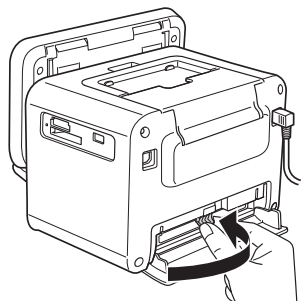

Caution: If the cartridge is not inserted correctly, PictureMate will not be able to print.

- 8** Close the cartridge door all the way.

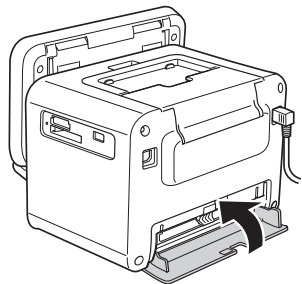

Checking Photo Cartridge Status

You can check the status of your photo cartridge at any time.

- 1** Press the **Menu** button on the remote control.
- 2** Select **Maintenance** and press **OK**.
- 3** Select **Check Cartridge Status** and press **OK**. You see the status displayed on the screen:

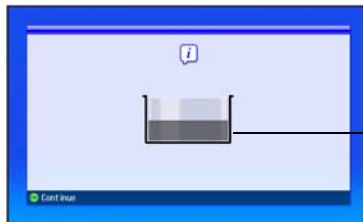

The gray square represents the ink level

- 4** Press **OK** to exit.

Note: If you see the photo cartridge low warning, you should buy a new Print Pack. See page 37 for details.

Take PictureMate With You

PictureMate's handle makes it easy to carry short distances.

Note: You can't raise the handle all the way up; it's designed to balance the printer's weight.

Packing Your PictureMate

If PictureMate is going to travel a longer distance, pack it carefully to help protect it from getting damaged.

Caution: Keep PictureMate out of the sun and don't leave it in your car or other location where it can get too hot or too cold. PictureMate may be damaged or ink may leak.

- 1** Press the  **On** button on PictureMate's side to turn it off.
- 2** Wait until the power light goes out, then unplug the power cable from the power outlet.
- 3** Remove all paper and printed photos.
- 4** Unplug the power adapter and any connected USB cable or device. Place the power cable and adapter in the PictureMate accessory box.

- 5** Close the paper support and remove the output tray. Then lower the screen.

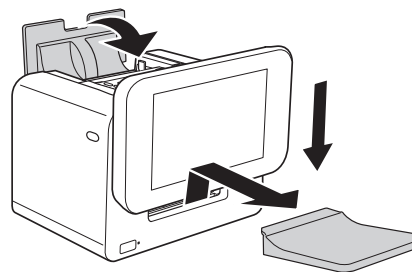

- 6** Place the remote control in the storage area on top of PictureMate.
- 7** Pack PictureMate in the box that it came in or the optional carrying case.

Caution: Make sure the photo cartridge is installed. Do not remove the photo cartridge before transporting. Don't place PictureMate on its side or upside down, or ink may leak.

Note: If your prints don't look as good after PictureMate has been moved, try aligning the print head (see page 47).

Set PictureMate Preferences

You can change the way PictureMate works by using the Setup menu. You can set the following preferences:

- Select the source for displaying and printing photos (see page 22)
- Change the Expansion setting for borderless printing (see page 20)
- Have text from your camera printed on your photos (see page 22)
- Change the way photos are saved after printing (see page 42)
- Make settings for printing directly from your camera (see your online *User's Guide*)
- Make settings for Bluetooth printing (see your online *User's Guide*)
- Set the date and time (see page 43)
- Set a time for PictureMate to turn on or off (see page 43)
- Change PictureMate's language (see page 44)
- Change the units of measurement from inches to millimeters (see page 44)
- Adjust the screen brightness (see page 44)
- Return the settings to their defaults (see page 44)

Changing the Way Photos are Saved

After you print, PictureMate asks if you want to save the pictures to its internal print history. You can change this to save pictures automatically (without confirmation), or not save at all.

- 1** Press the **Menu** button on the remote control.
- 2** Select **Setup** and press **OK**.
- 3** Select **Store to Printer Memory** and press **OK**.
- 4** Select one of the following, then press **OK**:
 - Confirm and save photo
 - Save photos
 - Do not save photos

Setting the Date and Time

- 1 Press the **Menu** button on the remote control.
- 2 Select **Setup** and press **OK**.
- 3 Select **Date/Time** and press **OK**.



- 4 Press **▲** or **▼** to change the year, then press **▶** to move to the month.
- 5 Repeat step 4 for the month and day, then press **OK**.
- 6 Repeat the process to set the time format and time, then press **OK**.

Setting Automatic Power On/Off

You can set times for PictureMate to turn on and off automatically.

- 1 Press the **Menu** button on the remote control.
- 2 Select **Setup** and press **OK**.
- 3 Select **Auto Power Settings** and press **OK**.
- 4 Press **OK** to select **Power ON Time**.
- 5 Select **Setup** and press **OK**. [WHAT IS None FOR?]
- 6 Set the time and press **OK**.
- 7 If you want to set a time for PictureMate to turn off automatically, repeat steps 1 to 3, then select **Power OFF Time**.
- 8 Repeat steps 5 and 6 to set the time.

Changing PictureMate's Language

You can change the language on PictureMate's screen to French.

- 1** Press the **Menu** button on the remote control.
- 2** Select **Setup** and press **OK**.
- 3** Select **Language** and press **OK**.
- 4** Select the language you want, then press **OK**.

Changing Units of Measurement

You can change the units of measurement from inches to millimeters.

- 1** Press the **Menu** button on the remote control.
- 2** Select **Setup** and press **OK**.
- 3** Select **Change Units** and press **OK**.
- 4** Select the units you want, then press **OK**.

Adjusting the Screen Brightness

You can make the screen brighter or dimmer.

- 1** Press the **Menu** button on the remote control.
- 2** Select **Setup** and press **OK**.
- 3** Select **LCD Brightness Adjustment** and press **OK**.
- 4** Press **▲** to increase the brightness, or **▼** to reduce it. You can see your setting reflected in the sample image.
- 5** When you're done, press **OK**.

Returning to Default Settings

You can return all PictureMate settings to the original default settings.

- 1** Press the **Menu** button on the remote control.
- 2** Select **Setup** and press **OK**.
- 3** Select **Restore Default Settings** and press **OK**.
- 4** When you see the confirmation, select **Yes** and press **OK** to restore the original settings.
- 5** Press **OK** to finish.

Printer Care and Troubleshooting

If you have problems or questions about how to use PictureMate, check the built-in help system:

- 1 Press the  button on the remote control.
- 2 Select **Troubleshooting** or **Contents**, then press **OK**.
- 3 Press **▲** or **▼** to select from the following:

Troubleshooting	Help contents
Print Quality Problems	Preparing to Print
Paper Problems	Printing Photos
Ink Problems	Printing from External Equipment
Memory Card Problems	Changing Settings
Other Problems	Maintaining the Printer
	Replacing the Photo Cartridge
	Using Other Functions

- 4 Press **OK** to display a list of topics.
- 5 Select the topic you want, then press **OK**.

- 6 Press **▼** to display additional information.

If you need additional help, read these sections:

- Checking and cleaning the print head (on page 46)
- Aligning the print head (on page 47)
- Cleaning PictureMate (on page 48)
- Replacing the remote control battery (on page 48)
- Printing and operation problems (on page 49)
- Software installation problems (on page 51)
- Print quality problems (on page 52)
- Problems with paper feeding (on page 53)
- Miscellaneous printout problems (on page 53)
- Where to get additional help (on page 54)

Checking and Cleaning the Print Head

If your print quality is not as good as it used to be—if photos are too light, are missing colors, or have lines running through them—PictureMate's print head nozzles may need cleaning.

You can check the nozzles and clean the print head if necessary.

- 1 Load paper in PictureMate.
- 2 Press the **Menu** button on the remote control.
- 3 Select **Maintenance** and press **OK**.
- 4 Select **Nozzle Check** and press **OK**.

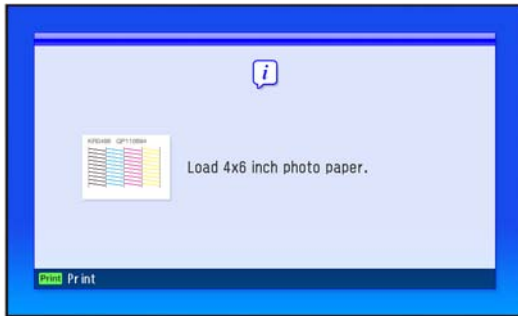

- 5 Press **Print**. The nozzle check pattern is printed.
- 6 Check the pattern to see if there are any gaps or missing lines.

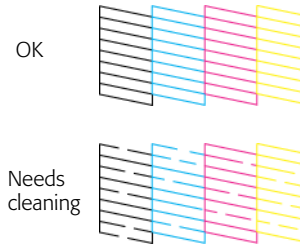

- If the pattern is OK, press **OK** to finish.
- If the pattern has gaps or missing lines, select **No** and press **OK**. Continue pressing **OK** to start Auto Cleaning.

Cleaning takes about 60 seconds. PictureMate makes some noise and you see an **Auto Cleaning** message.

If you don't see any improvement after cleaning three times, see "Print Quality Problems" on page 52.

Note: You can also clean the print head by selecting Auto Cleaning from the Maintenance menu. If you see the photo cartridge low warning, you may not be able to clean the print head until you replace the photo cartridge.

Aligning the Print Head

If you have moved PictureMate and print quality is not as good as it used to be—if your prints look fuzzy or have light or dark lines running through them—you may need to align the print head.

- 1** Load paper in PictureMate so you can print the head alignment pattern.
- 2** Press the **Menu** button on the remote control.
- 3** Select **Maintenance** and press **OK**.
- 4** Select **Print Head Alignment** and press **OK**.

- 5** Make sure paper is loaded, then press the **Print** button. The alignment pattern is printed:

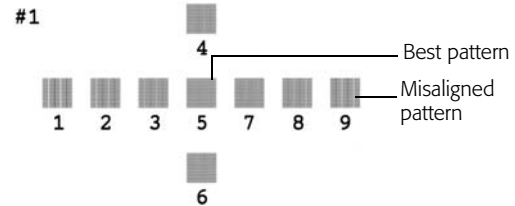

You see the Print Head Alignment screen:

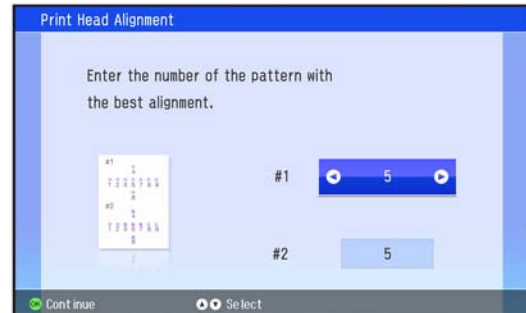

- 6 Look at the printed squares to determine which one is the most even, with no streaks or white lines. (You may need to use a magnifying glass.)
- 7 Press ◀ or ▶ to select the number for the best square (1 to 9) in set #1.
- 8 Press ▼ to move to #2.
- 9 Press ◀ or ▶ to highlight the number for the best square (1 to 9) in set #2. Then press **OK**.

PictureMate aligns the print head and exits the Maintenance menu.

Note: The square you select becomes the middle square (#5) the next time you align the print head.

Cleaning PictureMate

To keep PictureMate working at its best, you should clean it several times a year.

- 1 Turn off PictureMate, unplug the power cable, and disconnect the power adapter and any USB cable or device.
- 2 Remove all paper, then use a soft brush to clean any dust or dirt from the paper feeder and output tray.

- 3 Clean the PictureMate exterior with a soft, damp cloth.
- 4 Use a soft, dry cloth to clean the PictureMate screen. Do not use liquid or chemical cleaners.

Caution: Never use a hard or abrasive brush, or alcohol or thinner for cleaning; they can damage the components and case. Don't get water on the components and don't spray lubricants or oils inside PictureMate.

Replacing the Remote Control Battery

If the remote control stops working, you need to change the battery. Use a CR2025 lithium button battery only.

- 1 Turn the remote control upside down.
- 2 Push in the latch and slide out the battery holder. You may need to use a small screw driver or other tool.

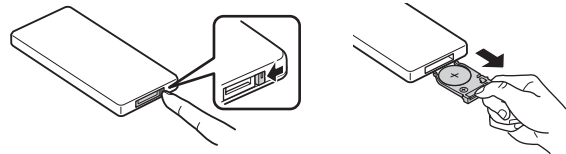

- 3** Remove the old battery. Then place a new battery in the holder.

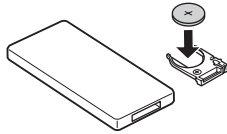

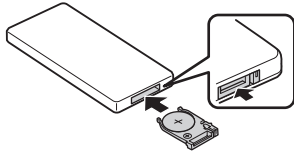

- 4** Push in the battery holder until it clicks into place.



Printing and Operation Problems

If you have problems with PictureMate, check the suggestions on the following pages. You can also press the  button on the remote control for troubleshooting help.

The power light and screen don't turn on.

- Press the  **On** button on PictureMate's side to turn it on. (You can only use the  **On** button on the remote control when the power light is orange.)
- Make sure the power cable and AC adapter are securely connected at both ends.
- Make sure your power outlet works and is not controlled by a wall switch or timer.

The screen goes blank or the printer shuts off automatically.

If Auto Power Settings are in effect, PictureMate will shut off automatically at the selected time. Press the  **On** button on the printer's side to turn it back on.

The power light is orange.

This indicates that PictureMate is in standby mode. You can turn it on by pressing the  **On** button on the remote control or on the printer itself.

A slideshow appears automatically.

If the remote control has not been used for about 3 minutes, a slideshow plays automatically. Press any

button on the remote control to return to the previous menu or screen.

PictureMate makes an unexpected noise after you install a photo cartridge.

The first time you install the photo cartridge, PictureMate charges its print head for about three and a half minutes. Wait until charging finishes before you turn it off, or it may charge improperly and use more ink the next time you turn it on.

Your PictureMate makes an unexpected noise when you turn it on or after it has been sitting for a while.

PictureMate is performing routine maintenance.

PictureMate sounds as though it is printing, but nothing prints.

- PictureMate may be preparing to print.
- The print head may need cleaning. See page 46.
- PictureMate won't work properly if it's tilted or at an angle. Place it on a flat, stable surface.
- Make sure paper is not jammed and is loaded correctly. See page 6.

Your memory card does not work correctly.

- Insert only one card at a time.
- Make sure you are using a compatible memory card. See page 6.
- PictureMate recognizes and can print the first 9,999 photos on a memory card.
- Photos must be in JPEG format and taken with a DCF-compliant camera.
- PictureMate cannot read progressive-scan JPEG files or RAW files.
- Make sure to format your memory card in your camera.

Printing is too slow.



- It takes a few moments for PictureMate to process your images before printing them.
- If PictureMate is in a hot or sunny location, move it to a cooler place and try printing again.
- If you print continuously for 30 minutes, PictureMate may slow down to prevent overheating. Leave the printer powered on, but allow it to cool off by not printing for at least 30 minutes.

For faster printing, try these tips:

- Don't print more than 40 pictures at a time.
- Photos with borders print faster than borderless photos.
- Turn off special features such as color effects and red-eye reduction.

The remote control doesn't work.

- Make sure the power light is on.

If PictureMate is in standby mode (the power light is orange), you can turn it on by pressing the  **On** button on the remote control. If the power light is off, you need to press the  **On** button on the printer itself.

- Make sure you are close enough (within 16 feet) and you point the remote directly at the printer.
- Make sure the battery is correctly installed in the remote control. You may need to replace the battery. See page 48.

You can't save photos from the Photo Storage menu.

The Photo Source may be set to **External Device** or **Print History**. You can only back up photos that are on a memory card. See page 28.

You can't raise PictureMate's handle straight up.

The handle is not designed to go all the way up.

Software Installation Problems

- Follow the instructions beginning on page 31 to install your software. Don't connect PictureMate to your computer until you are instructed to.
- Close other programs, including screen savers and virus protection software, and try installing again.
- Make sure your system meets the requirements listed in your online *User's Guide*.
- To print over a network, see the online *User's Guide* for instructions.

Print Quality Problems

You see banding (light lines) in your prints.

- The print head may need cleaning. See page 46.
- Be sure to print with the glossy or whiter side of the paper face up.
- The photo cartridge may need replacing. See page 38.

Your print is grainy.

- The print head may need aligning. See page 47.

Your print is blurry or smeared.

- Use PictureMate photo paper to ensure proper saturation, absorption of ink, and quality.
- Be sure to print with the glossy or whiter side of the paper face up.
- The print head may need cleaning. See page 46.
- The print head may need aligning. See page 47.
- Make sure your paper isn't damp or curled, or loaded face down (load it glossy or whiter side up). If it's damp or curled, load a new paper.

- Remove each photo from the output tray after printing. Let each photo sit for a minute before handling it.

Your print is faint or has gaps in the image.

- The print head may need cleaning. See page 46.
- The photo cartridge may be old or low. See page 37 to replace it.
- Make sure your paper isn't damaged, old, dirty, or loaded face down. If it is, load new paper with the glossy or whiter side up.

Colors in your photo are wrong or missing.

- Make sure the Color Effect setting is not set to **Black & White** or **Sepia**. See page 16.
- The print head may need cleaning. See page 46.
- The photo cartridge may be old or low. See page 37 to replace it.
- Colors may change slightly after your print dries. Wait for 24 hours and check your photo again.
- Turn on the **Fix Photo** or **P.I.M.** setting. See page 20.

Problems With Paper Feeding

Paper doesn't eject fully or is wrinkled.

The paper may be damp. Load new paper.

Paper doesn't feed correctly or jams.

- If paper doesn't feed, remove it, separate the sheets slightly, and reload it between the edge guides. Slide the guides to the edge of the paper, but don't make them too tight. See page 6.
- If multiple pages feed at once, remove the paper, separate the sheets, and carefully reload it.
- If paper jams, detach the output tray if necessary and remove the paper. Then press **OK** to clear the jam. Don't pull out jammed paper from the top of PictureMate.

If paper loads incorrectly or jams frequently:

- Use new paper loaded with the glossy or whiter side up, and separate the sheets slightly.
- Load a maximum of 20 sheets.
- Make sure your paper is beneath the arrow on the edge guides.

- Don't load plain paper; this may damage PictureMate.
- Use only PictureMate photo paper or Epson Premium Photo Paper Glossy or Semigloss. (See page 4.)
- Store paper flat to help prevent curling.

Miscellaneous Printout Problems

PictureMate prints blank pages.

- The print head may need cleaning. See page 46.
- The photo cartridge may be old or low. See page 37 to replace it.

The borders or layout are incorrect.

- Select a different Layout setting. See page 17.
- Crop your photo to enlarge and print only a part of it. See page 16.
- When you print borderless photos, PictureMate automatically expands your images. If your photos are cut off too much around the edges, you can adjust the amount of expansion. See page 21.

- Your photo size may not match the width/height proportions (aspect ratio) of PictureMate photo paper or the layout you're using. Photos may be cropped to fit the paper and layout. You can use the Crop/Trim Photo(s) feature to size your photo the way you want.

Where to Get Help

Epson Technical Support

Epson provides these technical support services:

Internet Support

Visit Epson's support website at epson.com/support and select your PictureMate Show for solutions to common problems. You can download drivers and documentation, get FAQs and troubleshooting advice, or e-mail Epson with your questions.

Speak to a Support Representative

Before you call Epson for support, please have the following information ready:

- Product name (PictureMate Show or PM 300)
- Product serial number (located on the bottom of PictureMate)

- Proof of purchase (such as a store receipt) and date of purchase
- Computer configuration
- Description of the problem

Then call:

- U.S.: (562) 276-7282, 6 AM to 6 PM, Pacific Time, Monday through Friday.
- Canada: (905) 709-2567, 6 AM to 6 PM, Pacific Time, Monday through Friday.

Days and hours of support are subject to change without notice. Toll or long distance charges may apply.

Purchase Supplies and Accessories

You can purchase genuine PictureMate Print Packs and accessories at Epson Supplies Central at www.epson.com/ink3 (U.S. sales) or www.epson.ca (Canadian sales). You can also purchase supplies from an Epson authorized reseller. To find the nearest reseller, call 800-GO-EPSON (800-463-7766).

Notices

Important Safety Instructions

Before using your PictureMate, read the following safety instructions to make sure you use it safely and effectively:

- Be sure to follow all warnings and instructions marked on the printer.
- If you use the printer in places where the use of electronic devices is limited, such as in airplanes or hospitals, follow all instructions in those places.
- Do not insert objects through the slots in the printer.
- Take care not to spill liquid on the printer and the AC adapter.
- Do not put your hand inside the printer or touch the photo cartridge during printing.
- Do not use aerosol products that contain flammable gases inside or around the printer. Doing so may cause fire.
- Always turn the printer off using the  **On** button. Do not unplug the printer or turn off the power to the outlet until the power light goes out.
- Before transporting the printer, make sure that the photo cartridge is installed.
- Leave the photo cartridge installed. Removing the cartridge can dehydrate the print head and may prevent the printer from printing or cause ink to leak out.

- Do not remove the memory card or turn off the printer while the computer and the memory card are communicating (when the memory card light is flashing).
- The methods for using memory cards vary according to card type. Be sure to refer to the documentation packaged with your memory card for details.
- Use only memory cards compatible with the printer (see page 7).
- Place the printer on a flat, stable surface that extends beyond the base of the printer in all directions. The printer will not operate properly if it is tilted at an angle. If you place the printer by the wall, leave more than 4 inches (10 cm) between the back of the printer and the wall.
- When storing or transporting the printer, do not tilt it, stand it on its side, or turn it upside down. Otherwise, ink may leak from the cartridge.
- Leave enough space in front of the printer for the paper to be fully ejected.
- Avoid places subject to rapid changes in temperature and humidity. Also, keep the printer and the AC adapter away from direct sunlight, strong light, water, or heat sources.

Caution: Keep PictureMate out of the sun and don't leave it in your car or other location where it can get too hot or too cold. Otherwise PictureMate may be damaged or ink may leak.



- Avoid places subject to dust, shock, or vibration.
- Leave enough room around the printer to allow for sufficient ventilation.
- Place the AC adapter near a wall outlet where the plug can be easily unplugged.
- Do not place or store the printer, the AC adapter, or the optional battery outdoors.
- Do not block or cover the vents and openings in the printer.
- Power supply cords should be placed to avoid abrasions, cuts, fraying, crimping, and kinking. Do not place objects on top of power-supply cords and do not allow the AC adapter or power-supply cords to be stepped on or run over. Be particularly careful to keep all power-supply cords straight at the ends and the points where they enter and leave the AC adapter.
- Use only the power-supply cord that comes with this product. Use of another cord may result in fire or electrical shock, or injury.
- The AC adapter model A431H is designed for use with the printer with which it was included. Do not attempt to use it with other electronic devices unless specified.
- Use only the type of power source indicated on the AC adapter's label, and always supply power directly from a standard domestic electrical outlet with the AC power cord that meets the relevant local safety standards.
- Avoid using outlets on the same circuit as photocopiers or air control systems that regularly switch on and off.
- Avoid using electrical outlets controlled by wall switches or automatic timers.
- Keep the entire computer system away from potential sources of electromagnetic interference, such as loudspeakers or the base units of cordless telephones.
- Do not use a damaged or frayed power cord, or the AC adapter or optional battery if damaged.
- If you use an extension cord with the printer, make sure that the total ampere rating of the devices plugged into the extension cord does not exceed the cord's ampere rating. Also, make sure that the total ampere rating of all devices plugged into the wall outlet does not exceed the wall outlet's ampere rating.
- Never disassemble, modify, or attempt to repair the AC adapter, power cord, printer, and options by yourself except as specifically explained in the printer's guides. Doing so may result in injury, electric shock, or fire.
- Unplug the printer and the AC adapter, remove the optional battery from the printer, and refer servicing to qualified service personnel under the following conditions:
 - The power cord or plug is damaged; liquid has entered the printer; the printer, the AC adapter, or the optional battery has been dropped or the casing damaged; the printer, the AC adapter, or the optional battery does not operate normally or exhibits a distinct change in performance. (Do not adjust controls that are not covered by the operating instructions.)
- Do not use with wet hands.

WARNING: The cords included with this product contain chemicals, including lead, known to the State of California to cause birth defects or other reproductive harm. **Wash hands after handling.** (This notice is provided in accordance with Proposition 65 in Cal. Health & Safety Code §25249.5 and following.)

Photo Cartridge Safety Instructions

- Keep photo cartridges out of the reach of children and do not drink the ink.
 - Do not shake the photo cartridge after removing it from the bag; this can cause leakage.
 - Be careful when you handle used photo cartridges, as there may be some ink remaining around the ink supply ports. If ink gets onto your skin, wash the area thoroughly with soap and water. If ink gets into your eyes, flush them immediately with water. If discomfort or vision problems continue after a thorough flushing, see a doctor immediately.
 - Do not remove or tear the label on the cartridge; this can cause leakage.
 - Do not dismantle photo cartridges or try to refill them. This could damage the print head.
 - Install the photo cartridge immediately after you remove it from its package. If you leave a cartridge unpacked for a long time before using it, normal printing may not be possible.
- Do not use a photo cartridge beyond the date printed on the cartridge carton; otherwise, it may result in reduced print quality. For best results, use up the photo cartridge within six months of installing it.
 - After bringing a photo cartridge inside from a cold storage site, allow it to warm up at room temperature for at least three hours before using it.
 - Store photo cartridges in a cool, dark place.
 - Store each photo cartridge so that the bottom of its packaging faces down.
 - Do not touch the green IC chip on the side of the cartridge. Doing so may prevent normal operation and printing.
 - The IC chip on the photo cartridge retains a variety of cartridge-related information, such as the amount of ink remaining, so that the cartridge may be removed and reinstalled freely. However, each time the cartridge is inserted, some ink is consumed because the printer automatically performs a reliability check.
 - If you remove the photo cartridge for later use, protect the ink supply ports from dirt and dust and store it in the same environment as the printer. A valve in the ink supply ports makes covers or plugs unnecessary, but the ink may stain items that come into contact with this area of the cartridge. Do not touch the ink supply ports or the surrounding area.

Screen Safety Instructions

- The screen contains a few small bright or dark spots. These are normal and do not mean that the screen is damaged in any way.
- Only use a dry, soft cloth to clean the screen. Do not use liquid or chemical cleansers.
- If the screen is damaged, contact your dealer. If the liquid crystal solution gets on your hands, wash them thoroughly with soap and water. If the liquid crystal solution gets into your eyes, flush them immediately with water. If discomfort or vision problems remain after a thorough flushing, see a doctor immediately.
- Please consult your state and local regulations regarding disposal or recycling. Do not put in the trash.

Remote Control Battery Safety Instructions

- If battery acid gets into your eyes or on your skin, immediately rinse the affected area thoroughly with water and seek medical treatment. If a battery is swallowed, seek medical treatment immediately.
- Use only a CR2025 lithium button battery for the remote control according to the directions in the user documentation.
- Do not handle the battery with wet hands or use it near water.
- Do not expose the battery to water or high humidity.
- Do not drop, puncture, disassemble, mutilate, or short-circuit the battery.

- Do not place the battery near or into fire or water.
- Do not use a battery that is leaking or damaged in any way.
- Do not charge the battery.
- Keep the battery away from heat sources.
- Do not leave the battery in a vehicle to prevent the battery from overheating.
- Prevent the battery from coming into contact with metal objects that could short-circuit it, such as coins or keys.
- Do not solder wires or terminals directly to the battery.
- Keep the battery away from open flame if it leaks or smells strange.
- If overheating, discoloration, or deformation occur, remove the battery from this product and do not use it.
- When not using the printer for a long period of time, remove the battery from the remote control and store it separately to avoid over-discharging the battery.
- Do not store the battery where the temperature or humidity is very high.
- Store the battery out of children's reach.

Warning: Do not dispose of batteries as ordinary refuse. Instead, dispose of them in a collection or recycle box in accordance with local laws. Do not incinerate or dispose of the battery in fire.



For users in the United States and Canada:
This mark indicates that the battery will be recycled by RBRC. When you dispose of the battery, contact RBRC.

For California customers only:
The lithium batteries in this product contain
Perchlorate Material - special handling may apply,
See www.dtsc.ca.gov/hazardouswaster/perchlorate

Epson America, Inc. Limited Warranty

What Is Covered: Epson America, Inc. ("Epson") warrants to the original retail purchaser that the Epson printer covered by this limited warranty statement, if purchased and operated only in the United States or Canada, will be free from defects in workmanship and materials for a period of one (1) year from the date of original purchase. For warranty service, you must provide proof of the date of original purchase.

What Epson Will Do To Correct Problems: Should your Epson printer prove defective during the warranty period, please call the Epson ConnectionSM at (562) 276-7282 (U.S.) or (905) 709-2567 (Canada) for warranty repair instructions and return authorization. An Epson service technician will provide telephone diagnostic service to determine whether the printer requires service. If service is needed, Epson will, at its option, exchange or repair the printer without charge for parts or labor. If Epson authorizes an exchange for the defective unit, Epson will ship a replacement printer to you, freight prepaid, so long as you use an address in Canada or the U.S. (excluding Puerto Rico and U.S. Possessions). Shipments to other locations will be made freight collect. You are responsible for securely packaging the defective unit and returning it to Epson within five (5) working days of receipt of the replacement. Epson requires a debit or a credit card number to secure the cost of the replacement printer in the event that you fail to return the defective one. If your printer

is being repaired, Epson will direct you to send your printer to Epson or its authorized service center, where the printer will be fixed and sent back to you. You are responsible for packing the printer and for all costs to and from the Epson authorized service center. When warranty service involves the exchange of the printer or a part, the item replaced becomes Epson property. The replacement printer or part may be new or refurbished to the Epson standard of quality, and, at Epson's option, may be another model of like kind and quality. Epson's liability for replacement of the covered printer will not exceed the original retail selling price of the covered printer. Exchange products and parts assume the remaining warranty period of your original product covered by this limited warranty.

What This Warranty Does Not Cover: This warranty does not apply to refurbished or reconditioned products. This warranty covers only normal use in the United States and Canada. Using this product for continuous production or similar high duty purposes is not considered normal use; damage, maintenance or service from such use will not be covered under this warranty. This warranty is not transferable. This warranty does not cover any color change or fading of prints or reimbursement of materials or services required for reprinting. This warranty does not cover damage to the Epson product caused by parts or supplies not manufactured, distributed or certified by Epson. This warranty does not cover ribbons, ink cartridges or third party parts, components, or peripheral devices added to the Epson product after its shipment from Epson, e.g., dealer or user-added boards or components. Epson is not responsible for warranty service should the Epson label or logo or the rating label or serial number be removed or should the product fail to be properly

maintained or fail to function properly as a result of misuse, abuse, improper installation, neglect, improper shipping, damage caused by disasters such as fire, flood, and lightning, improper electrical current, software problems, interaction with non-Epson products, or service other than by an Epson Authorized Servicer. If a claimed defect cannot be identified or reproduced, you will be held responsible for the costs incurred.

THE WARRANTY AND REMEDY PROVIDED ABOVE ARE EXCLUSIVE AND IN LIEU OF ALL OTHER EXPRESS OR IMPLIED WARRANTIES INCLUDING, BUT NOT LIMITED TO, THE IMPLIED WARRANTIES OF MERCHANTABILITY, NON-INFRINGEMENT OR FITNESS FOR A PARTICULAR PURPOSE. SOME LAWS DO NOT ALLOW THE EXCLUSION OF IMPLIED WARRANTIES. IF THESE LAWS APPLY, THEN ALL EXPRESS AND IMPLIED WARRANTIES ARE LIMITED TO THE WARRANTY PERIOD IDENTIFIED ABOVE. UNLESS STATED HEREIN, ANY STATEMENT OR REPRESENTATIONS MADE BY ANY OTHER PERSON OR FIRM ARE VOID. EXCEPT AS PROVIDED IN THIS WRITTEN WARRANTY, NEITHER EPSON AMERICA, INC. NOR ITS AFFILIATES SHALL BE LIABLE FOR ANY LOSS, INCONVENIENCE, OR DAMAGE, INCLUDING DIRECT, SPECIAL, INCIDENTAL OR CONSEQUENTIAL DAMAGES, RESULTING FROM THE USE OR INABILITY TO USE THE EPSON PRODUCT, WHETHER RESULTING FROM BREACH OF WARRANTY OR ANY OTHER LEGAL THEORY.

In Canada, warranties include both warranties and conditions.

Some jurisdictions do not allow limitations on how long an implied warranty lasts, and some jurisdictions do not allow the exclusion or limitation of incidental or consequential

damages, so the above limitations and exclusions may not apply to you. This warranty gives you specific legal rights and you may have other rights which vary from jurisdiction to jurisdiction.

To find the Epson Authorized Reseller nearest you, visit our website at: <http://www.epson.com>.

To find the Epson Customer Care Center nearest you, visit epson.com/support.

You can also write to: Epson America, Inc., P.O. Box 93012, Long Beach, CA 90809-3012

How Many Photos Will I Get From a PictureMate Print Pack?

Epson has packaged the PictureMate Photo Cartridge with a quantity of 4 × 6 PictureMate Photo Paper, so that purchasing supplies for PictureMate is convenient and affordable. The number of sheets of photo paper in your PictureMate Print Pack is stated on the Print Pack's box. The photo ink cartridge in the Print Pack contains enough ink to allow borderless, color printing of about the stated number of sheets.

Our estimate of the number of photos you can print with a PictureMate Print Pack is based on test printing with a range of 20 different color photos. Actual yields will vary based on images printed, print settings, paper type, frequency of use and temperature. For example, printing many copies of the same photo, or printing many black and white or sepia photos, may result in fewer photos per PictureMate Photo Cartridge. Also, the PictureMate Photo Cartridge once installed should be replaced with a new one within 6

months. For print quality, a variable amount of ink remains in the cartridge after the “Replace Print Pack” indicator comes on.

You may be able to print more photos with a PictureMate Photo Cartridge than the number of sheets of photo paper in your PictureMate Print Pack. In this case the cartridge monitor indicates the cartridge can still be used. You can continue printing with paper from another PictureMate Print Pack or Epson Premium Photo Paper Glossy in the 4 × 6 borderless size which is available from many resellers or Epsonstore.com. There are other photo papers available but most are not formulated to be fully compatible with the PictureMate Photo Cartridge. Using other papers may result in poor color reproduction, print quality problems or more fading.

Both a PictureMate Photo Cartridge and some PictureMate Photo Paper were included in the box with your PictureMate printer. The included cartridge contains enough ink to allow borderless, color printing of about the number of included paper sheets. The other comments above also apply to the cartridge and paper included in the printer box.

PictureMate Print Pack Satisfaction Guarantee

If you are dissatisfied because you receive fewer prints than the number of sheets of paper stated on your PictureMate Print Pack, you can return the remaining sheets of paper with the dated sales receipt and UPC code from the PictureMate Print Pack packaging within one year of purchase and Epson will give you a pro-rated refund for the number of sheets returned, plus a maximum of \$1.10 for postage. The amount of the refund depends on the number of sheets stated on

your Print Pack and the Print Pack’s suggested retail price. For example, if you purchased a 150-sheet Print Pack of glossy photo paper with a suggested retail price of \$39.99, Epson will refund 27 cents per sheet returned (\$39.99 divided by 150 sheets equals 27 cents per sheet). This Satisfaction Guarantee is a prorated refund that covers only end-user claims in the U.S. and Canada. It does not cover use of any non-Epson ink or paper, commercial use of the printer, or paper consumed by proofs or printing errors.

This Satisfaction Guarantee also applies to the PictureMate Photo Cartridge and PictureMate Photo Paper which were included in the box with your PictureMate printer, if you are dissatisfied because you receive fewer prints with the cartridge than the number of sheets included. The per-sheet refund in that case is 27 cents.

Refund Procedure

Please follow this refund procedure:

- 1** Print out the PictureMate Print Pack Satisfaction Guarantee Form, found on the web page below, or request this form to be mailed to you by calling (562) 276-1347 for U.S.A. and Puerto Rico or (905) 709-8676 for Canadian residents.

www.mypicturemate.com/satisfactionguarantee

- 2** Send the following items to:

PictureMate Print Pack Satisfaction Guarantee
P.O. Box 400067
EL Paso, TX 88540-0067

- a) Fully completed PictureMate Print Pack Satisfaction Guarantee Form
- b) Original UPC code of PictureMate Print Pack
- c) Copy of PictureMate Print Pack receipt
- d) Remaining PictureMate Print Pack paper from the original PictureMate Print Pack.

If you are making a claim based on the number of prints you were able to make with the initial cartridge and paper which were included in the box with your PictureMate printer, please submit:

- a) Fully completed PictureMate Print Pack Satisfaction Guarantee Form
- b) Copy of Original UPC code of PictureMate printer
- c) Copy of PictureMate printer receipt
- d) Remaining paper which was included in the PictureMate printer box

Customer claim status inquiries: (800) 305-7305.

Declaration of Conformity

According to 47CFR, Part 2 and 15 for Class B Personal Computers and Peripherals; and/or CPU Boards and Power Supplies used with Class B Personal Computers:

We: Epson America, Inc.

Located at: MS: 3-13
3840 Kilroy Airport Way
Long Beach, CA 90806-2469
Telephone: (562) 290-5254

Declare under sole responsibility that the product identified herein, complies with 47CFR Part 2 and 15 of the FCC rules as a Class B digital device. Each product marketed is identical to the representative unit tested and found to be compliant with the standards. Records maintained continue to reflect the equipment being produced can be expected to be within the variation accepted, due to quantity production and testing on a statistical basis as required by 47CFR §2.909. Operation is subject to the following two conditions: (1) this device may not cause harmful interference, and (2) this device must accept any interference received, including interference that may cause undesired operation.

Trade Name: Epson

Type of Product: Ink Jet Printer

Model: B384A

FCC Compliance Statement

For United States Users

This equipment has been tested and found to comply with the limits for a Class B digital device, pursuant to Part 15 of the FCC Rules. These limits are designed to provide reasonable protection against harmful interference in a residential installation. This equipment generates, uses, and can radiate radio frequency energy and, if not installed and used in accordance with the instructions, may cause harmful interference to radio or television reception. However, there is no guarantee that interference will not occur in a particular installation. If this equipment does cause interference to radio and television reception, which can be determined by

turning the equipment off and on, the user is encouraged to try to correct the interference by one or more of the following measures:

- Reorient or relocate the receiving antenna.
- Increase the separation between the equipment and receiver.
- Connect the equipment into an outlet on a circuit different from that to which the receiver is connected.
- Consult the dealer or an experienced radio/TV technician for help.

WARNING: The connection of a non-shielded equipment interface cable to this equipment will invalidate the FCC Certification of this device and may cause interference levels which exceed the limits established by the FCC for this equipment. It is the responsibility of the user to obtain and use a shielded equipment interface cable with this device. If this equipment has more than one interface connector, do not leave cables connected to unused interfaces. Changes or modifications not expressly approved by the manufacturer could void the user's authority to operate the equipment.

For Canadian Users

This Class B digital apparatus complies with Canadian ICES-003.

Cet appareil numérique de la classe B est conforme à la norme NMB-003 du Canada.

Copyright Notice

All rights reserved. No part of this publication may be reproduced, stored in a retrieval system, or transmitted in any form or by any means, electronic, mechanical, photocopying, recording, or otherwise, without the prior written permission of Seiko Epson Corporation. The information contained herein is designed only for use with this Epson product. Epson is not responsible for any use of this information as applied to other printers.

Neither Seiko Epson Corporation nor its affiliates shall be liable to the purchaser of this product or third parties for damages, losses, costs, or expenses incurred by purchaser or third parties as a result of: accident, misuse, or abuse of this product or unauthorized modifications, repairs, or alterations to this product, or (excluding the U.S.) failure to strictly comply with Seiko Epson Corporation's operating and maintenance instructions.

Seiko Epson Corporation shall not be liable for any damages or problems arising from the use of any options or any consumable products other than those designated as Original Epson Products or Epson Approved Products by Seiko Epson Corporation.

A Note Concerning the Responsible Use of Copyrighted Materials

Epson encourages each user to be responsible and respectful of the copyright laws when using any Epson product. While some countries' laws permit limited copying or reuse of copyrighted material in certain circumstances, those circumstances may not be as broad as some people assume. Contact your legal advisor for any questions regarding copyright law.

Trademarks

EPSON, PictureMate, PRINT Image Matching, and the PRINT Image Matching logo are registered trademarks, PictureMate Show is a trademark, and EPSON Exceed Your Vision is a registered logomark of Seiko Epson Corporation.

Epson Connection is a service mark of Epson America, Inc.

The logo for Exif Print, featuring the text "Exif Print" in a stylized font with a series of dots above the "i" in "Print".The logo for SDHC (Secure Digital High Capacity), featuring the letters "SD" above "HC" in a stylized font.The logo for PictBridge, featuring a stylized graphic of a camera lens and the text "PictBridge".The logo for PRINT Image Matching, featuring a circular arrow icon and the text "PRINT Image Matching" inside a square border.The logo for MEMORY STICK, featuring a stylized graphic of a memory stick and the text "MEMORY STICK" below it.

MEMORY STICK PRO™

General Notice: Other product names used herein are for identification purposes only and may be trademarks of their respective owners. Epson disclaims any and all rights in those marks.

This information is subject to change without notice.

© 2013 Epson America, Inc. 4/13

Index

A

Accessories, 4, 26, 54

Adapter

 Bluetooth, 26 to 27

 memory card, 7

Adjust Photo settings menu, 20

Aligning print head, 47 to 48

All photos, printing, 12 to 13

Auto Cleaning, 46, 52

Auto Power Settings, 43

Auto shutoff, 49

B

Backing up photos, 28 to 29

Banding, fixing, 46, 52

Battery

 replacing, 48 to 49

 safety instructions, 58

Black and white prints, 21

Blank pages, 53

Blank screen, 49

Bluetooth printing, 26 to 27

Blurry prints, 52

Borderless expansion, 21

Borders

 printing with, 12

 problems, 53

Buttons

 Display, 11, 17

 On, 6, 9

 question mark, 45

 remote control, 5

C

Cable

 power, 41

 USB, 25, 31, 33 to 35, 41

Camera

 printing from, 24 to 25

 printing text from, 22

 selected photos (DPOF), 14

- Canceling printing, 13
- Care of PictureMate, 45 to 49
- Cartridge, photo *see* Photo cartridge
- CD, installing software from, 31 to 36
- Change units setting, 44
- Checking nozzles, 46, 47
- Choosing photos, 10 to 14
- Cleaning
 - PictureMate, 48
 - print head, 46, 52
- Color
 - effects, 21
 - fixing, 20 to 21
 - problems, 52
- Computer
 - Bluetooth printing, 26 to 27
 - connecting to PictureMate, 31 to 35
 - installing software on, 31 to 36
 - software installation problems, 51
- Copies, number of, 11 to 12
- Cropping, 16 to 19
- Customizing PictureMate, 42 to 44
- Cut-off photos, fixing, 21

D

- Date and time, setting, 43
- Date, printing, 12
- Default settings, 44
- Deleting photos, 29 to 30
- Display button, 11, 17
- Displaying prints, 15
- DOC (Declaration of Conformity), 62
- DPOF (Digital Print Order Format), 14
- Drive, external, *see* External device

E

- Enhancing photos, 20 to 21
- Epson
 - accessories, 4, 26, 54
 - technical support, 54
- Exif Print, 20
- Expansion, borderless, 21
- External device
 - port, 25 to 26
 - printing from, 24 to 26
 - selecting as source, 22, 26

F

- Faint prints, 52
- FCC compliance, 62 to 63
- File formats, 4
- Fixing photos, 20 to 21
- Flash memory drive, printing from, 25 to 26

G

- Gaps in image, 46, 52
- Grainy prints, 52

H

- Handle, PictureMate, 41
- Help
 - Epson, 54
 - on screen, 45

I

- Image
 - formats, 4
 - quality, 20 to 21
 - quality problems, 52

I

- Incorrect
 - colors, 52
 - margins, 21, 53
- Ink, see Photo cartridge
- Internet support, 54

J

- Jammed paper, 53
- JPEG, 4

L

- Language, changing, 44
- Layout
 - problems, 53
 - settings, 17 to 19
- Lights
 - memory card, 7 to 8
 - power, 9, 49
- Lines in photos, fixing, 46, 52
- Loading paper, 8 to 9, 53

M

Macintosh

- Bluetooth printing, 26
- installing software for, 34 to 36, 51

Maintenance, 45 to 49

Manuals, 4

Margins

- incorrect, 21, 53
- printing with, 12

Measurement, changing units, 44

Memory card

- adapters, 7
- compatibility, 7
- inserting, 6
- light, 7 to 8
- problems, 50
- removing, 8, 31

Missing colors, 52

N

Noise, PictureMate, 50

Nozzles, checking and cleaning, 46

O

On button, 6, 9

Output tray, 8, 41

P

Packing PictureMate, 41

Paper

- buying, 4, 54
- feeding problems, 53
- jam, 53
- loading, 8 to 9, 53
- output tray, 9, 41
- storing, 15
- support, 8 to 9, 41

PDA, printing from, 26 to 27

Phone, printing from, 26 to 27

Photo

- backing up, 28 to 29
- choosing, 10 to 14
- correction, 20 to 21
- cropping, 16 to 19
- deleting, 29 to 30
- displaying, 15
- DPOF, 14
- fixing, 20 to 21
- fixing cut off, 21
- fixing red eye, 19
- formats, 4
- paper, see Paper
- quality problems, 52
- quality, adjusting, 20 to 21
- reserved, 14
- rotating, 23
- saving, 28 to 29, 42
- selecting source, 22
- sizing, 18 to 19
- storing, 15

Photo cartridge

- buying, 4, 54
- information, 60 to 62
- replacing, 37 to 40
- safety instructions, 57
- status, 40

Photo Storage menu, 28 to 30

PictBridge camera, 24 to 25

PIM (PRINT Image Matching), 20

Power

- light, 49
- problems, 49
- saving, 9
- turning on, 6, 9, 49

Power cable, 41

Preferences, setting, 42 to 44

Previewing printing, 11 to 14

Print

- preview, 11 to 14
- speed, increasing, 50

Print head

- aligning, 47 to 48
- cleaning, 46, 52

Print history, 22, 28 to 30, 42

PRINT Image Matching, 20

Print Pack

- buying, 4, 54

- information, 60 to 62

- replacing, 37 to 40

- status, 40

Print quality problems, 52

Printing

- all photos, 12 to 13

- Bluetooth, 26 to 27

- cancelling, 13

- from camera, 24 to 25

- from external device, 24 to 26

- from slideshow, 13 to 14

- individual photos, 10 to 12

- preview, 11 to 14

- problems, 49 to 51

- wireless, 26 to 27

Problems

- border or layout, 53

- color, 52

- memory card, 50

- paper feeding, 53

- paper jam, 53

- power, 49

- print quality, 52

- printing, 49 to 51

- remote control, 51

- screen, 49

- slow printing, 50

- software installation, 51

Proof sheet, 12

Q

Quality

- adjusting, 20 to 21

- problems, 52

R

- Red-eye, fixing, 19
- Remote control
 - buttons, 5
 - problems, 51
 - replacing battery, 48 to 49
- Replacing photo cartridge, 37 to 40
- Reserved photos, 14
- Resetting preferences, 42 to 44
- Resolution, 4
- Rotating photos, 23

S

- Safety instructions, 55 to 58
- Saving photos, 42
- Scene Detection, 21
- Screen
 - adjusting angle, 10
 - adjusting brightness, 44
 - problems, 49
 - safety instructions, 58
- Sepia, 21
- Service, 54
- Settings, default, 44

- Sharpness, fixing, 21
- Sizing photos, 18 to 19
- Slideshow
 - printing from, 13 to 14
 - problems, 49
 - starting, 13
 - stopping, 14
- Slow printing, 50
- Smear prints, 52
- Software, installing, 31 to 36
- Source, selecting, 26
- Speed, increasing, 50
- Standby mode, 9
- Start Here sheet, 4
- Stopping printing, 13
- Storing paper and prints, 15
- Supplies, 4, 26, 54
- Support, paper, 8, 41

T

- Technical support, 54
- Thumb drive, printing from, 22, 25 to 26
- Time, setting, 43
- Transporting PictureMate, 41

Troubleshooting, 45 to 53

Turning printer on or off, 6, 9, 49

U

USB cable, 25, 31, 33 to 35, 41

User's Guide, 4

W

Wallet-size photos, 17 to 18

Warranty, 59 to 60

Where to get help, 54

Windows

- Bluetooth printing, 26

- installing software for, 31 to 34, 51

Wireless printing, 26 to 27

Z

Zooming in and out, 16 to 19

Need a New Print Pack?



The PictureMate Print Pack has everything you need to print in one box: photo paper and a photo cartridge.

The following Print Packs and accessories are available:

Product	Part Number
Glossy photo paper (150 sheets) and photo cartridge	T5846
Matte photo paper (100 sheets) and photo cartridge	T5845-M
PictureMate carrying case	PMBAG06
Bluetooth® Photo Print Adapter	C12C824383

You can also buy a Print Pack and other PictureMate accessories from an Epson authorized reseller. To find the nearest reseller, call 800-GO-EPSON (800-463-7766). Or you can purchase online at www.epsonstore.com (U.S. sales) or www.epson.ca (Canadian sales).

For more PictureMate information, special offers, and related accessories, visit www.MyPictureMate.com.

Print



Show



EPSON[®]
EXCEED YOUR VISION



412504500

CPD-27492R1
Printed in XXXXXX