



Most Widely Accepted and Trusted

ICC-ES Report

ESR-3037

ICC-ES | (800) 423-6587 | (562) 699-0543 | www.icc-es.org

Reissued 08/2015
This report is subject to renewal 08/2016.

DIVISION: 03 00 00—CONCRETE
SECTION: 03 16 00—CONCRETE ANCHORS
DIVISION: 05 00 00—METALS
SECTION: 05 05 19—POST-INSTALLED CONCRETE ANCHORS

REPORT HOLDER:

SIMPSON STRONG-TIE COMPANY INC.

**5956 WEST LAS POSITAS BOULEVARD
PLEASANTON, CALIFORNIA 94588**

EVALUATION SUBJECT:

**SIMPSON STRONG-TIE® STRONG-BOLT® 2 WEDGE ANCHOR FOR
CRACKED AND UNCRACKED CONCRETE**



Look for the trusted marks of Conformity!

“2014 Recipient of Prestigious Western States Seismic Policy Council (WSSPC) Award in Excellence”



A Subsidiary of

ICC-ES Evaluation Reports are not to be construed as representing aesthetics or any other attributes not specifically addressed, nor are they to be construed as an endorsement of the subject of the report or a recommendation for its use. There is no warranty by ICC Evaluation Service, LLC, express or implied, as to any finding or other matter in this report, or as to any product covered by the report.



ICC-ES Evaluation Report

ESR-3037

Reissued August 2015

Revised February 2016

This report is subject to renewal August 2016.

www.icc-es.org | (800) 423-6587 | (562) 699-0543

A Subsidiary of the International Code Council®

DIVISION: 03 00 00—CONCRETE
Section: 03 16 00—Concrete Anchors

DIVISION: 05 00 00—METALS
Section: 05 05 19—Post-installed Concrete Anchors

REPORT HOLDER:

SIMPSON STRONG-TIE COMPANY INC.
 5956 WEST LAS POSITAS BOULEVARD
 PLEASANTON, CALIFORNIA 94588
 (925) 560-9000
www.strongtie.com

EVALUATION SUBJECT:

**SIMPSON STRONG-TIE® STRONG-BOLT® 2 WEDGE
 ANCHOR FOR CRACKED AND UNCRACKED CONCRETE**

1.0 EVALUATION SCOPE
Compliance with the following codes:

- 2015, 2012, 2009, and 2006 *International Building Code*® (IBC)
- 2015, 2012, 2009, and 2006 *International Residential Code*® (IRC)

Property evaluated:

Structural

2.0 USES

The Simpson Strong-Tie® Strong-Bolt® 2 wedge anchor is used to resist static, wind and seismic tension and shear loads in cracked and uncracked normal-weight concrete and lightweight concrete having a specified compressive strength, f'_c , of 2,500 psi to 8,500 psi (17.2 MPa to 58.6 MPa).

The $\frac{3}{8}$ -inch-, $\frac{1}{2}$ -inch-, $\frac{5}{8}$ -inch- and $\frac{3}{4}$ -inch-diameter (9.5 mm, 12.7 mm, 15.9 mm and 19.1 mm) anchors may be installed in the soffit of cracked and uncracked normal-weight or sand-lightweight concrete-filled steel deck having a minimum specified compressive strength, f'_c , of 3,000 psi (20.7 MPa).

The $\frac{3}{8}$ -inch- and $\frac{1}{2}$ -inch-diameter (9.5 mm and 12.7 mm) anchors may be installed in the topside of cracked and uncracked normal-weight or sand-lightweight concrete-filled steel deck having a minimum member thickness, $h_{min,deck}$, as noted in [Tables 5A](#) and [5B](#) of this report and a specified compressive strength, f'_c , of 2,500 psi to 8,500 psi (17.2 MPa to 58.6 MPa).

The Strong-Bolt® 2 complies with Section 1901.3 of the 2015 IBC and Section [1909](#) of the 2012 IBC, Section [1912](#) of the 2009 and 2006 IBC. The anchors are alternatives to cast-in-place anchors described in Section [1908](#) of the 2012 IBC, Section [1911](#) of the 2009 and 2006 IBC. The anchors may also be used where an engineered design is submitted in accordance with Section R301.1.3 of the IRC.

3.0 DESCRIPTION
3.1 Strong-Bolt® 2:

3.1.1 General: Strong-Bolt® 2 anchors are torque-controlled, mechanical expansion anchors consisting of an anchor body, expansion clip, nut, and washer. A typical anchor (carbon steel version) is shown in [Figure 1](#) of this report. The anchor body has a tapered mandrel formed on the installed end of the anchor and a threaded section at the opposite end. The taper of the mandrel increases in diameter toward the installed end of the anchor. The three-segment expansion clip wraps around the tapered mandrel. Before installation, this expansion clip is free to rotate about the mandrel. The anchor is installed in a predrilled hole. When the anchor is set by applying torque to the hex nut, the mandrel is drawn into the expansion clip, which engages the drilled hole and transfers the load to the base material. Pertinent dimensions are as set forth in [Tables 1A](#) and [1B](#) of this report.

3.1.2 Strong-Bolt® 2, Carbon Steel: The anchor bodies are manufactured from carbon steel material with zinc plating conforming to [ASTM B633](#), SC1, Type III. The expansion clip for the $\frac{1}{4}$ -inch-, $\frac{3}{8}$ -inch-, $\frac{1}{2}$ -inch-, $\frac{5}{8}$ -inch- and $\frac{3}{4}$ -inch-diameter carbon steel Strong-Bolt 2 anchors is fabricated from carbon steel and conforms to [ASTM A568](#). The expansion clip for the 1-inch-diameter carbon steel Strong-Bolt 2 anchor is fabricated from stainless steel and conforms to [ASTM A240](#), Grade 316. The hex nut for the carbon steel Strong-Bolt 2 anchor conforms to [ASTM A563](#), Grade A. The washer for the carbon steel Strong-Bolt 2 anchor conforms to [ASTM F844](#). The available anchor diameters under this report are $\frac{1}{4}$ inch, $\frac{3}{8}$ inch, $\frac{1}{2}$ inch, $\frac{5}{8}$ inch, $\frac{3}{4}$ inch and 1 inch (6.4 mm, 9.5 mm, 12.7 mm, 15.9 mm, 19.1 mm, and 25.4 mm).

3.1.3 Strong-Bolt® 2, Stainless Steel: The anchor body of the $\frac{1}{4}$ -inch-diameter stainless steel Strong-Bolt 2 anchor is manufactured from either AISI Type 304 or AISI Type 316 stainless steel. The anchor bodies of the $\frac{3}{8}$ -inch-, $\frac{1}{2}$ -inch-, $\frac{5}{8}$ -inch-, and $\frac{3}{4}$ -inch-diameter stainless steel Strong-Bolt 2 anchors are manufactured from AISI Type 316 stainless steel. The expansion clip for the stainless steel Strong-Bolt 2 anchor conform to AISI Type 316

stainless steel. The hex nut and washer for the Type 304 and Type 316 stainless steel Strong-Bolt 2 conform to AISI Type 304 and Type 316 steel, respectively. The available anchor diameters under this report are $\frac{1}{4}$ inch, $\frac{3}{8}$ inch, $\frac{1}{2}$ inch, $\frac{5}{8}$ inch and $\frac{3}{4}$ inch (6.4 mm, 9.5 mm, 12.7 mm, 15.9 mm and 19.1 mm).

3.2 Concrete:

Normal-weight and lightweight concrete must conform to Sections 1903 and 1905 of the IBC, as applicable.

3.3 Profile Steel Deck:

The profile steel deck must comply with the configuration in [Figures 4](#) and [5](#) and have a minimum base-steel thickness of 0.035 inch (0.889 mm) [20 gauge]. Steel must comply with [ASTM A653/A653M](#) SS Grade 33 with a minimum yield strength of 33,000 psi (228 MPa).

4.0 DESIGN AND INSTALLATION

4.1 Strength Design:

4.1.1 General: Design strength of anchors complying with the 2015 IBC as well as Section R301.1.3 of the 2015 IRC, must be determined in accordance with [ACI 318-14](#) and this report.

Design strength of anchors complying with the 2012 IBC, as well as Section R301.1.3 of the 2012 IRC, must be determined in accordance with [ACI 318-11](#) Appendix D and this report.

Design strength of anchors complying with the 2009 IBC and Section [R301.1.3](#) of the 2009 IRC must be in accordance with [ACI 318-08](#) Appendix D and this report.

Design strength of anchors complying with the 2006 IBC and Section [R301.1.3](#) of the 2006 IRC must be in accordance with [ACI 318-05](#) Appendix D and this report.

Design parameters provided in [Tables 1A](#) through 6 and references to [ACI 318](#) are based on the 2015 IBC (ACI 318-14) and on the 2012 IBC (ACI 318-11) unless noted otherwise in Sections 4.1.1 through 4.1.12 of this report. The strength design of anchors must comply with ACI 318-14 17.3.1 or ACI 318-11 D.4.1, as applicable, except as required in ACI 318-14 17.2.3 or ACI 318-11 D.3.3, as applicable. A design example in accordance with the 2009 IBC is given in [Figure 7](#) of this report.

Strength reduction factors, ϕ , as given in ACI 318-14 17.3.3 or ACI 318-11 D.4.3, as applicable, must be used for load combinations calculated in accordance with Section 1605.2 of the IBC and Section 5.3 of ACI 318-14 or Section 9.2 of ACI 318-11, as applicable. Strength reduction factors, ϕ , as given in ACI 318-11 D.4.4 must be used for load combinations calculated in accordance with ACI 318-11 Appendix C.

The value of f'_c used in the calculations must be limited to 8,000 psi (55.2 MPa), maximum, in accordance with ACI 318-14 17.2.7 or ACI 318-11 D.3.7, as applicable.

4.1.2 Requirements for Static Steel Strength in Tension: The nominal steel strength of a single anchor in tension, N_{sa} , in accordance with ACI 318-14 17.4.1.2 or ACI 318-11 D.5.1.2, as applicable, is given in [Tables 2A](#) and [2B](#) of this report. The strength reduction factor, ϕ , corresponding to a brittle steel element must be used for the carbon steel 1-inch-diameter anchor as described in [Table 2A](#) of this report. For all other anchors the strength reduction factor, ϕ , corresponding to a ductile steel element must be used as described in [Tables 2A](#) and [2B](#) of this report.

4.1.3 Requirements for Static Concrete Breakout Strength in Tension: The nominal concrete breakout strength of a single anchor or group of anchors in tension, N_{cb} and N_{cbg} , must be calculated in accordance with ACI 318-14 17.4.2 or ACI 318-11 D.5.2, as applicable, with modifications as described in this section. The basic concrete breakout strength in tension, N_b , must be calculated in accordance with ACI 318-14 17.4.2.2 or ACI 318-11 D.5.2.2, as applicable, using the values of h_{ef} and k_{cr} as described in [Tables 2A](#) and [2B](#) of this report. The nominal concrete breakout strength in tension, N_{cb} or N_{cbg} , in regions of a concrete member where analysis indicates no cracking at service loads in accordance with ACI 318-14 17.4.3.6 or ACI 318-11 D.5.2.6, as applicable, must be calculated with the value of k_{uncr} as given in [Tables 2A](#) and [2B](#) of this report and with $\psi_{c,N} = 1.0$, as described in [Tables 2A](#) and [2B](#) of this report.

For anchors installed in the soffit of sand-lightweight or normal-weight concrete over profile steel deck floor and roof assemblies, as shown in [Figure 4](#), determination of the concrete breakout strength in accordance with ACI 318-14 17.4.2 or ACI 318-11 D.5.2, as applicable, is not required.

4.1.4 Requirements for Static Pullout Strength in Tension: The nominal pullout strength of a single anchor in tension in accordance with ACI 318-14 17.4.3 or ACI 318-11 D.5.3, as applicable, in cracked and uncracked concrete, $N_{p,cr}$ and $N_{p,uncr}$, is given in [Tables 2A](#) and [2B](#) of this report. Where analysis indicates no cracking at service load levels in accordance with ACI 318-14 17.4.3.6 or ACI 318-11 D.5.3.6, as applicable, the nominal pullout strength in uncracked concrete, $N_{p,uncr}$, applies. Where values for $N_{p,cr}$ or $N_{p,uncr}$ are not provided in [Tables 2A](#) and [2B](#), the pullout strength does not need to be considered. In lieu of ACI 318-14 17.4.3.6 or ACI 318-11 D.5.3.6, as applicable, $\psi_{c,p} = 1.0$ for all design cases. The nominal pullout strength in cracked concrete must be adjusted for concrete strengths according to Eq-1:

$$N_{p,f_c} = N_{p,cr} \left(\frac{f_c}{2,500} \right)^n \quad (\text{lb, psi}) \quad (\text{Eq-1})$$

$$N_{p,f_c} = N_{p,cr} \left(\frac{f_c}{17.2} \right)^n \quad (\text{N, MPa})$$

where f'_c is the specified compressive strength and n is the factor defining the influence of concrete strength on the pullout strength. For the stainless steel $\frac{3}{8}$ -inch-diameter anchor in cracked concrete n is 0.3. For the stainless steel $\frac{5}{8}$ -inch-diameter anchor in cracked concrete n is 0.4. For all other cases n is 0.5.

In regions where analysis indicates no cracking in accordance with ACI 318-14 17.4.3.6 or ACI 318 D.5.3.6, as applicable, the nominal pullout strength in tension must be adjusted by calculation according to Eq-2:

$$N_{p,f_c} = N_{p,uncr} \left(\frac{f_c}{2,500} \right)^n \quad (\text{lb, psi}) \quad (\text{Eq-2})$$

$$N_{p,f_c} = N_{p,uncr} \left(\frac{f_c}{17.2} \right)^n \quad (\text{N, MPa})$$

where f'_c is the specified compressive strength and n is the factor defining the influence of concrete strength on the pullout strength. For the stainless steel $\frac{3}{8}$ -inch-diameter anchor in uncracked concrete, n is 0.3. For the stainless steel $\frac{1}{4}$ -inch-diameter anchor and stainless steel $\frac{3}{4}$ -inch-diameter anchor in uncracked concrete, n is 0.4. For all other cases, n is 0.5.

The pullout strength in cracked and uncracked concrete for anchors installed in the soffit of sand-lightweight or normal-weight concrete over profile steel deck floor and roof assemblies, as shown in [Figure 4](#), is given in [Tables](#)

4A and 4B of this report. The nominal pullout strength in cracked concrete must be adjusted for concrete strength according to Eq-1, using the value of $N_{p,deck,cr}$ in lieu of $N_{p,cr}$, and the value of 3,000 psi (20.7 MPa) must be substituted for the value of 2,500 psi (17.2 MPa) in the denominator. Where analysis indicates no cracking at service load levels in accordance with ACI 318-14 17.4.3.6 or ACI 318-11 D.5.3.6, as applicable, the nominal pullout strength in uncracked concrete must be adjusted for concrete strength according to Eq-2, using the value of $N_{p,deck,uncr}$ in lieu of $N_{p,uncr}$, and the value of 3,000 psi (20.7 MPa) must be substituted for the value of 2,500 psi (17.2 MPa) in the denominator. The value of $\Psi_{c,p} = 1.0$ for all cases.

4.1.5 Requirements for Static Steel Strength in Shear:

The nominal steel strength in shear, V_{sa} , of a single anchor in accordance with ACI 318-14 17.5.1.2 or ACI 318-11 D.6.1.2, as applicable, is given in [Tables 3A](#) and [3B](#) of this report and must be used in lieu of values derived by calculation from ACI 318-14 Eq. 17.5.1.2a or ACI 318-11, Eq. D-29, as applicable. The strength reduction factor, ϕ , corresponding to a brittle steel element must be used for the carbon steel 1-inch-diameter anchor as described in [Table 3A](#) of this report. For all other anchors the strength reduction factor, ϕ , corresponding to a ductile steel element must be used for all anchors as described in [Tables 3A](#) and [3B](#) of this report.

The shear strength, $V_{sa,deck}$, of anchors installed in the soffit of sand-lightweight or normal-weight concrete over profile steel deck floor and roof assemblies, as shown in [Figure 4](#), is given in [Tables 4A](#) and [4B](#) of this report.

4.1.6 Requirements for Static Concrete Breakout Strength in Shear: The nominal concrete breakout strength of a single anchor or group of anchors in shear, V_{cb} or V_{cbg} , must be calculated in accordance with ACI 318-14 17.5.2 or ACI 318-11 D.6.2, as applicable, with modifications as described in this section. The basic concrete breakout strength in shear, V_b , must be calculated in accordance with ACI 318-14 17.5.2.2 or ACI 318-11 D.6.2.2, as applicable, using the values of λ_e and d_a provided in [Tables 3A](#) and [3B](#) of this report.

For anchors installed in the topside of concrete-filled steel deck assemblies, as shown in [Figure 5](#), the nominal concrete breakout strength of a single anchor or group of anchors in shear, V_{cb} or V_{cbg} , respectively, must be calculated in accordance with ACI 318-14 17.5.2 or ACI 318-11 D.6.2, as applicable, using the actual member thickness, $h_{min,deck}$, in the determination of A_{Vc} . Minimum member topping thickness for anchors in the topside of concrete-filled steel deck assemblies is given in [Tables 5A](#) and [5B](#) of this report.

For anchors installed in the soffit of sand-lightweight or normal-weight concrete over profile steel deck floor and roof assemblies, as shown in [Figure 4](#), calculation of the concrete breakout strength in accordance with ACI 318-14 17.5.2 or ACI 318-11 D.6.2, as applicable, is not required.

4.1.7 Requirements for Static Concrete Pryout Strength in Shear: The nominal concrete pryout strength of a single anchor or group of anchors in shear, V_{cp} or $V_{cp,g}$, must be calculated in accordance with ACI 318-14 17.5.3.1 or ACI 318-11 D.6.3, as applicable, modified by using the value of k_{cp} described in [Tables 3A](#) and [3B](#) of this report and the value of N_{cb} or N_{cbg} as calculated in accordance with Section 4.1.3 of this report.

For anchors installed in the soffit of sand-lightweight or normal-weight concrete over profile steel deck floor and roof assemblies, as shown in [Figure 4](#), calculation of the

concrete pryout strength in accordance with ACI 318-14 17.5.3.1 or ACI 318-11 D.6.3, as applicable, is not required.

4.1.8 Requirements for Seismic Design:

4.1.8.1 General: For load combinations including seismic, the design must be performed in accordance with ACI 318-14 17.2.3 or ACI 318-11 D.3.3, as applicable. Modifications to ACI 318-14 2.3 17.2.3 shall be applied under Section 1905.1.8 of the 2015 IBC. For the 2012 IBC, Section [1905.1.9](#) must be omitted. Modifications to ACI 318-08 and ACI 318-05 D.3.3, as applicable, must be applied under Section [1908.1.9](#) of the 2009 IBC, Section [1908.1.16](#) of the 2006 IBC, respectively.

The carbon steel 1-inch-diameter anchor complies with ACI 318-14 2.3 or ACI 318-11 D.1, as applicable, as a brittle steel element. All other anchors comply with ACI 318-14 2.3 or ACI 318-11 D.1, as applicable, as ductile steel elements and must be designed in accordance with ACI 318-14 Section 17.2.3.4, 17.2.3.5, or 17.2.3.6 or ACI 318-11 Section D.3.3.4, D.3.3.5, or D.3.3.6 or ACI 318-08 Section D.3.3.4, D.3.3.5 or D.3.3.6, or ACI 318-05 Section D.3.3.4 or D.3.3.5, as applicable, with the modifications noted above.

4.1.8.2 Seismic Tension: The nominal steel strength and nominal concrete breakout strength for anchors in tension must be calculated in accordance with ACI 318-14 17.4.1 an 17.4.2 or ACI 318-11 D.5.1 and D.5.2, as applicable, as described in Sections 4.1.2 and 4.1.3 of this report.

In accordance with ACI 318-14 17.4.3.2 or ACI 318-11 D.5.3.2, as applicable, the appropriate value for nominal pullout strength in tension for seismic loads, $N_{p,eq}$ or $N_{p,deck,eq}$, provided in [Tables 2A](#), [2B](#), [4A](#) and [4B](#) of this report, must be used in lieu of N_p . If no values for $N_{p,eq}$ or $N_{p,deck,eq}$ are given in [Table 2A](#), [2B](#), [4A](#) or [4B](#), the pullout strength for seismic loads need not be evaluated. The values of $N_{p,eq}$ or $N_{p,deck,eq}$ can be adjusted for concrete strength according to Section 4.1.4.

4.1.8.3 Seismic Shear: The nominal concrete breakout and concrete pryout strength for anchors in shear must be calculated in accordance with ACI 318-14 17.5.2 and 17.5.3 or ACI 318-11 D.6.2 and D.6.3, as applicable, as described in Sections 4.1.6 and 4.1.7 of this report. In accordance with ACI 318-14 17.5.1.2 or ACI 318-11 D.6.1.2, as applicable, the appropriate value for nominal steel strength in shear for seismic loads, $V_{sa,eq}$ or $V_{sa,deck,eq}$, provided in [Tables 3A](#), [3B](#), [4A](#) and [4B](#) of this report, must be used in lieu of V_{sa} .

4.1.9 Requirements for Interaction of Tensile and Shear Forces: For loadings that include combined tension and shear, the design must be performed in accordance with ACI 318-14 17.6 or ACI 318-11 D.7, as applicable.

4.1.10 Requirements for Critical Edge Distance: In applications where $c < c_{ac}$ and supplemental reinforcement to control splitting of the concrete is not present, the concrete breakout strength in tension for uncracked concrete, calculated according to ACI 318-14 17.4.2 or ACI 318-11 D.5.2, as applicable, must be further multiplied by the factor $\Psi_{cp,N}$ given by Eq-3:

$$\Psi_{cp,N} = \frac{c}{c_{ac}} \quad (\text{Eq-3})$$

where the factor $\Psi_{cp,N}$ need not be taken as less than $\frac{1.5h_{ef}}{c_{ac}}$. For all other cases, $\Psi_{cp,N} = 1.0$. In lieu of ACI 318-14 17.7.6 or ACI 318-11 D.8.6, as applicable, values of c_{ac} provided in [Tables 1A](#) and [1B](#) of this report must be used.

4.1.11 Requirements for Minimum Member Thickness, Minimum Anchor Spacing and Minimum Edge Distance: In lieu of ACI 318-14 17.7.1 and 17.7.3 or ACI 318-11 D.8.1 and D.8.3, as applicable, values of s_{min} and c_{min} provided in [Tables 1A](#) and [1B](#) of this report must be used. In lieu of ACI 318-14 17.7.5 or ACI 318-11 D.8.5, as applicable, minimum member thickness, h_{min} , must be in accordance with [Tables 1A](#) and [1B](#) of this report.

For $3/4$ -inch-diameter carbon steel, and $3/8$ -inch-, $1/2$ -inch- and $5/8$ -inch-diameter stainless steel Strong-Bolt[®] 2 anchors, additional combinations for minimum edge distance c_{min} and minimum spacing s_{min} may be derived by linear interpolation between the boundary given in [Tables 1A](#) and [1B](#) and as shown in [Figure 6](#) of this report.

For anchors installed in the topside of normal-weight or sand-lightweight concrete over profile steel deck floor and roof assemblies, the anchor must be installed in accordance with [Table 5A](#) for carbon steel anchors and [Table 5B](#) for stainless steel anchors, and [Figure 5](#) of this report.

For anchors installed in the soffit of steel deck assemblies, the anchors must be installed in accordance with [Figure 4](#) and must have a minimum axial spacing along the flute equal to the greater of $3h_{ef}$ or 1.5 times the flute width.

4.1.12 Lightweight Concrete: For the use of anchors in lightweight concrete the modification factor λ_a equal to 0.8 λ is applied to all values of $\sqrt{f'_c}$ affecting N_n and V_n .

For ACI 318-14 (2015 IBC), ACI 318-11 (2012 IBC) and ACI 318-08 (2009 IBC), λ shall be determined in accordance with the corresponding version of ACI 318.

For ACI 318-05 (2006 IBC), λ shall be taken as 0.75 for all lightweight concrete and 0.85 for sand-lightweight concrete. Linear interpolation shall be permitted if partial sand replacement is used. In addition, the pullout strengths $N_{p,cr}$, $N_{p,uncr}$, and N_{eq} shall be multiplied by the modification factor, λ_a , as applicable.

For anchors installed in the soffit of sand-lightweight concrete-filled steel deck and floor and roof assemblies, further reduction of the pullout values provided in this report is not required.

4.2 Allowable Stress Design (ASD):

4.2.1 General: Where design values for use with allowable stress design (working stress design) load combinations calculated in accordance with Section 1605.3 of the IBC, must be established using the following equations:

$$T_{allowable,ASD} = \frac{\phi N_n}{\alpha} \quad (\text{Eq-3})$$

and

$$V_{allowable,ASD} = \frac{\phi V_n}{\alpha} \quad (\text{Eq-4})$$

where:

$T_{allowable,ASD}$ = Allowable tension load (lbf or kN)

$V_{allowable,ASD}$ = Allowable shear load (lbf or kN)

ϕN_n = Lowest design strength of an anchor or anchor group in tension as determined in accordance with ACI 318-14 Chapter 17 and 2015 IBC Section 1905.1.8, ACI 318-11 Appendix D, ACI 318-08 Appendix D, and 2009 IBC Section 1908.1.9, ACI 318-05 Appendix D an IBC Section 1908.1.16,

and Section 4.1 of this report, as applicable. (lbf or kN).

ϕV_n = Lowest design strength of an anchor or anchor group in shear as determined in accordance with ACI 318-14 Chapter 17 and 2015 IBC Section 1905.1.8, ACI 318-11 Appendix D, ACI 318-08 Appendix D, and 2009 IBC Section 1908.1.9 or 2006 IBC Section 1908.1.16, and Section 4.1 of this report, as applicable. (lbf or kN).

α = A conversion factor calculated as a weighted average of the load factors for the controlling load combination. In addition, α shall include all applicable factors to account for non-ductile failure modes and required over-strength.

The requirements for member thickness, edge distance and spacing, as described in this report, must apply. An example calculation for the derivation of allowable stress design tension values is presented in [Table 6](#).

4.2.2 Interaction of Tensile and Shear Forces: The interaction of tension and shear loads must be consistent with ACI 318-14 17.6 or ACI 318-11, -08, -05 D.7, as applicable, as follows:

If $T_{applied} \leq 0.2T_{allowable,ASD}$, then the full allowable strength in shear, $V_{allowable,ASD}$, must be permitted.

If $V_{applied} \leq 0.2V_{allowable,ASD}$, then the full allowable strength in tension, $T_{allowable,ASD}$, must be permitted.

$$\text{For all other cases: } \frac{T_{applied}}{T_{allowable,ASD}} + \frac{V_{applied}}{V_{allowable,ASD}} \leq 1.2$$

4.3 Installation:

Installation parameters are provided in [Tables 1A](#) and [1B](#) and [4A](#) and [4B](#), and in [Figures 2](#), [3](#) and [4](#). Anchor locations must comply with this report and the plans and specifications approved by the code official. The Strong-Bolt[®] 2 must be installed in accordance with the manufacturer's published instructions and this report. Anchors must be installed in holes drilled into the concrete using carbide-tipped drill bits conforming to [ANSI B212.15-1994](#). The nominal drill bit diameter must be equal to the nominal diameter of the anchor. The minimum drilled hole depth, h_{hole} , is given in [Tables 1A](#) and [1B](#). The drilled hole must be cleaned, with all dust and debris removed using compressed air. The anchor, nut, and washer must be assembled so that the top of the nut is flush with the top of the anchor. The anchor must be driven into the hole using a hammer until the proper embedment depth is achieved. The nut and washer must be tightened against the base material or material to be fastened until the appropriate installation torque value specified in [Tables 1A](#) and [1B](#) is achieved.

For anchors installed in the topside of normal-weight or sand-lightweight concrete over profile steel deck floor and roof assemblies, installation parameters are provided in [Tables 5A](#) and [5B](#) and in [Figure 5](#) of this report.

For installation in the soffit of normal-weight or sand-lightweight concrete over profile steel deck floor and roof assemblies, the hole diameter in the steel deck must not exceed the diameter of the hole in the concrete by more than $1/8$ inch (3.2 mm). The minimum drilled hole depth, h_{hole} , is given in [Tables 4A](#) and [4B](#). For edge distance and member thickness requirements for installations into the soffit of concrete over steel deck assemblies, see [Figure 4](#). For installation in the soffit of sand-lightweight or normal-weight concrete over profile steel deck floor and roof

assemblies, torque must be applied until the appropriate installation torque value specified in [Tables 4A](#) and [4B](#) is achieved.

4.4 Special Inspection:

Periodic special inspection is required in accordance with Section [1705.1.1](#) and [Table 1705.3](#) of the 2015 IBC and of the 2012 IBC or Section [1704.15](#) of the 2009 IBC, or Section [1704.13](#) of the 2006 IBC. The special inspector must make periodic inspections during anchor installation to verify anchor type, anchor dimensions, concrete type, concrete compressive strength, drill-bit type, hole dimensions, hole cleaning procedures, anchor spacing, edge distances, concrete member thickness, anchor embedment, tightening torque and adherence to the manufacturer's published installation instructions. The special inspector must be present as often as required by the "statement of special inspection." Under the IBC, additional requirements as set forth in Sections 1705, 1706 and 1707 must be observed, where applicable.

5.0 CONDITIONS OF USE

The Simpson Strong-Tie® Strong Bolt® 2 wedge anchor described in this report complies with, or is a suitable alternative to what is specified in, those codes listed in Section 1.0 of this report, subject to the following conditions:

- 5.1 The anchors must be installed in accordance with the manufacturer's published installation instructions and this report. In case of a conflict, this report governs.
- 5.2 Anchor sizes, dimensions and minimum embedment depths are as set forth in this report.
- 5.3 The $\frac{1}{4}$ -inch-diameter (6.4 mm) anchors must be limited to use in uncracked normal-weight concrete and lightweight concrete having a specified compressive strength, f'_c , of 2,500 psi to 8,500 psi (17.2 MPa to 58.6 MPa).

The anchor may also be installed in the top of uncracked normal-weight and sand-lightweight concrete over profile steel deck where concrete thickness above upper flute meets the minimum thicknesses specified in [Tables 1A & 1B](#).

- 5.4 The $\frac{3}{8}$ -inch- through 1-inch-diameter (9.5 mm through 25.4 mm) anchors must be installed in cracked and uncracked normal-weight and lightweight concrete having a specified compressive strength, f'_c , of 2,500 psi to 8,500 psi (17.2 MPa to 58.6 MPa).

The anchors may also be installed in the top of cracked and uncracked normal-weight and sand-lightweight concrete over profile steel deck where concrete thickness above upper flute meets the minimum thicknesses specified in [Tables 1A & 1B](#).

- 5.5 The $\frac{3}{8}$ -inch through $\frac{3}{4}$ -inch-diameter (9.5 mm through 19.1 mm) anchors must be installed in the soffit of cracked and uncracked sand-lightweight or normal-weight concrete over profile steel deck having a minimum specified compressive strength, f'_c , of 3,000 psi (20.7 MPa).
- 5.6 The $\frac{3}{8}$ -inch- and $\frac{1}{2}$ -inch-diameter (9.5 mm and 12.7 mm) anchors may be installed in the topside of cracked and uncracked normal-weight or sand-lightweight concrete-filled steel deck having a minimum specified compressive strength, f'_c , of 2,500 psi to 8,500 psi (17.2 MPa to 58.6 MPa).
- 5.7 The value of f'_c used for calculation purposes must not exceed 8,000 psi (55.2 MPa).

5.8 Strength design values must be established in accordance with Section 4.1 of this report.

5.9 Allowable stress design values are established in accordance with Section 4.2 of this report.

5.10 Anchor spacing and edge distance, as well as minimum member thickness, must comply with [Tables 1A, 1B, 4A, 4B, 5A, 5B](#); and [Figures 4, 5, and 6](#), of this report.

5.11 Prior to anchor installation, calculations and details demonstrating compliance with this report must be submitted to the code official. The calculations and details must be prepared by a registered design professional where required by the statutes of the jurisdiction in which the project is to be constructed.

5.12 Since an ICC-ES acceptance criteria for evaluating data to determine the performance of expansion anchors subjected to fatigue or shock loading is unavailable at this time, the use of these anchors under such conditions is beyond the scope of this report.

5.13 The $\frac{3}{8}$ -inch through 1-inch (9.5 mm through 25.4 mm) anchors may be installed in regions of concrete where cracking has occurred or where analysis indicates cracking may occur ($f_t > f_r$), subject to the conditions of this report.

5.14 The $\frac{1}{4}$ -inch-diameter (6.4 mm) anchors may be used to resist short-term loading due to wind or seismic forces, in locations designated as Seismic Design Categories A and B under the IBC, subject to the conditions of this report.

5.15 The $\frac{3}{8}$ -inch through 1-inch (9.5 mm through 25.4 mm) anchors may be used to resist short-term loading due to wind or seismic forces, in locations designated as Seismic Design Categories A through F under the IBC, subject to the conditions of this report.

5.16 Where not otherwise prohibited in the code, Strong-Bolt® 2 anchors are permitted for use with fire-resistance-rated construction provided that at least one of the following conditions is fulfilled:

- Anchors are used to resist wind or seismic forces only.
- Anchors that support a fire-resistance-rated envelope or a fire-resistance-rated membrane, are protected by approved fire-resistance-rated materials, or have been evaluated for resistance to fire exposure in accordance with recognized standards.
- Anchors are used to support nonstructural elements.

5.17 Use of zinc-plated carbon steel anchors is limited to dry, interior locations.

5.18 Periodic special inspection must be provided in accordance with Section 4.4 of this report.

5.19 The anchors are manufactured by Simpson Strong-Tie Company Inc., under an approved quality-control program with inspections by ICC-ES.

6.0 EVIDENCE SUBMITTED

Data in accordance with the ICC-ES Acceptance Criteria for Mechanical Anchors in Concrete Elements (AC193), dated October 2015, including optional suitability tests for seismic tension and shear; profile steel deck soffit tests; and quality control documentation.

7.0 IDENTIFICATION

The Strong-Bolt® 2 anchors are identified in the field by dimensional characteristics, head stamp, material specifications and packaging. The Strong-Bolt® 2 anchor has the Simpson Strong-Tie Company Inc., No Equal logo ≠ stamped on the expansion clip, and a length identification code embossed on the exposed threaded

end. [Table 7](#) shows the length identification codes. The packaging label bears the manufacturer's name and contact information, anchor name, anchor size and length, quantity, and the evaluation report number (ESR-3037).

TABLE 1A—CARBON STEEL STRONG-BOLT® 2 ANCHOR INSTALLATION INFORMATION¹

CHARACTERISTIC	SYMBOL	UNITS	NOMINAL ANCHOR SIZE											
			Carbon Steel											
			¹ / ₄ inch ⁵	³ / ₈ inch ⁶	¹ / ₂ inch ⁶	⁵ / ₈ inch ⁶	³ / ₄ inch ⁶	1 inch ⁶						
Installation Information														
Nominal Diameter	d_a^3	in.	¹ / ₄	³ / ₈	¹ / ₂	⁵ / ₈	³ / ₄	1						
Drill Bit Diameter	d	in.	¹ / ₄	³ / ₈	¹ / ₂	⁵ / ₈	³ / ₄	1						
Baseplate Clearance Hole Diameter ²	d_c	in. (mm)	⁵ / ₁₆ (7.9)	⁷ / ₁₆ (11.1)	⁹ / ₁₆ (14.3)	¹¹ / ₁₆ (17.5)	⁷ / ₈ (22.2)	¹ / ₂ (28.6)						
Installation Torque	T_{inst}	ft-lbf (N-m)	4 (5.4)	30 (40.7)	60 (81.3)	90 (122.0)	150 (203.4)	230 (311.9)						
Nominal Embedment Depth	h_{nom}	in. (mm)	³ / ₄ (45)	¹ / ₂ (48)	² / ₃ (73)	² / ₄ (70)	³ / ₈ (98)	³ / ₈ (86)	⁵ / ₈ (130)	⁴ / ₈ (105)	⁵ / ₄ (146)	⁵ / ₄ (133)	⁹ / ₄ (248)	
Effective Embedment Depth	h_{ef}	in. (mm)	¹ / ₂ (38)	¹ / ₂ (38)	² / ₂ (64)	² / ₄ (57)	³ / ₈ (86)	² / ₄ (70)	⁴ / ₂ (114)	³ / ₈ (86)	5 (127)	⁴ / ₂ (114)	9 (229)	
Minimum Hole Depth	h_{hole}	in. (mm)	⁷ / ₈ (48)	2 (51)	3 (76)	3 (76)	⁴ / ₈ (105)	³ / ₈ (92)	⁵ / ₈ (137)	⁴ / ₈ (111)	6 (152)	⁵ / ₂ (140)	10 (254)	
Minimum Overall Anchor Length	λ_{anch}	in. (mm)	² / ₄ (57)	² / ₄ (70)	³ / ₂ (89)	³ / ₄ (95)	⁵ / ₂ (140)	⁴ / ₂ (114)	6 (152)	⁵ / ₂ (140)	7 (178)	7 (178)	13 (330)	
Critical Edge Distance	c_{ac}	in. (mm)	² / ₂ (64)	⁶ / ₂ (165)	6 (152)	⁶ / ₂ (165)	⁶ / ₂ (165)	⁷ / ₂ (191)	⁷ / ₂ (191)	9 (229)	9 (229)	8 (203)	18 (457)	13 ¹ / ₂ (343)
Minimum Edge Distance	c_{min}	in. (mm)	³ / ₄ (45)	6 (152)	7 (178)	4 (102)	4 (102)	⁶ / ₂ (165)	⁶ / ₂ (165)	8 (203)				
	for $s \geq$	in. (mm)	- -	- -	- -	- -	- -	- -	- -	8 (203)				
Minimum Spacing	s_{min}	in. (mm)	² / ₄ (57)	3 (76)	7 (178)	4 (102)	4 (102)	5 (127)	7 (178)	8 (203)				
	for $c \geq$	in. (mm)	- -	- -	- -	- -	- -	- -	8 (203)					
Minimum Concrete Thickness	h_{min}	in. (mm)	³ / ₄ (83)	³ / ₄ (83)	⁴ / ₂ (114)	⁴ / ₂ (114)	⁵ / ₂ (140)	6 (152)	⁵ / ₂ (140)	⁷ / ₈ (200)	⁶ / ₄ (172)	⁸ / ₄ (222)	9 (229)	13 ¹ / ₂ (343)
Additional Data														
Specified Yield Strength	f_{ya}	psi (MPa)	56,000 (386)	92,000 (634)	85,000 (586)				70,000 (483)		60,000 (414)			
Specified Tensile Strength	f_{uta}	psi (MPa)	70,000 (483)	115,000 (793)					110,000 (758)		78,000 (538)			
Minimum Tensile and Shear Stress Area	A_{se}^3	in ² (mm ²)	0.0318 (21)	0.0514 (33)	0.105 (68)		0.166 (107)		0.270 (174)		0.472 (305)			
Axial Stiffness in Service Load Range - Cracked and Uncracked Concrete ⁴	β	lb./in (N/mm)	73,700 ⁴ (12,898) ⁴	34,820 (6,098)	63,570 (11,133)		91,370 (16,001)		118,840 (20,812)		299,600 (52,468)			

For SI: 1 inch = 25.4 mm, 1 ft-lbf = 1.356 N-m, 1 psi = 6.89 Pa, 1 in² = 645 mm², 1 lbf/in = 0.175 N/mm.

¹The information presented in this table is to be used in conjunction with the design criteria of [ACI 318-14](#) Chapter 17 or [ACI 318-11](#) Appendix D, as applicable.

²The clearance must comply with applicable code requirements for the connected element.

³For the 2006 IBC d_o replaces d_a , $A_{se,N}$ replaces A_{se} .

⁴The tabulated value of β for ¹/₄-inch-diameter carbon steel Strong-Bolt® 2 anchor is for installations in uncracked concrete only.

⁵The ¹/₄-inch-diameter (6.4 mm) anchor may be installed in top of uncracked normal-weight and sand-lightweight concrete over profile steel deck where concrete thickness above upper flute meets the minimum thicknesses specified in this table.

⁶The ³/₈-inch- through 1-inch-diameter (9.5 mm through 25.4 mm) anchors may be installed in topside of cracked and uncracked normal-weight and sand-lightweight concrete over profile steel deck where concrete thickness above upper flute meets the minimum thicknesses specified in this table, and Tables 5A and 5B for the ³/₈-inch and ¹/₂-inch-diameter (9.5 mm and 12.7 mm) anchors.

TABLE 1B—STAINLESS STEEL STRONG-BOLT® 2 ANCHOR INSTALLATION INFORMATION¹

CHARACTERISTIC	SYMBOL	UNITS	NOMINAL ANCHOR SIZE								
			Stainless Steel								
			¹ / ₄ inch ⁵	³ / ₈ inch ⁶	¹ / ₂ inch ⁶	⁵ / ₈ inch ⁶	³ / ₄ inch ⁶				
Installation Information											
Nominal Diameter	d_a^3	in.	¹ / ₄	³ / ₈	¹ / ₂	⁵ / ₈	³ / ₄				
Drill Bit Diameter	d	in.	¹ / ₄	³ / ₈	¹ / ₂	⁵ / ₈	³ / ₄				
Baseplate Clearance Hole Diameter ²	d_c	in. (mm)	⁵ / ₁₆ (7.9)	⁷ / ₁₆ (11.1)	⁹ / ₁₆ (14.3)	¹¹ / ₁₆ (17.5)	⁷ / ₈ (22.2)				
Installation Torque	T_{inst}	ft-lbf (N-m)	4 (5.4)	30 (40.7)	60 (81.3)	80 (108.5)	150 (203.4)				
Nominal Embedment Depth	h_{nom}	in. (mm)	¹ / ₄ (45)	¹ / ₂ (48)	³ / ₄ (73)	¹ / ₂ (70)	³ / ₈ (98)	³ / ₈ (86)	⁵ / ₈ (130)	⁴ / ₈ (105)	⁵ / ₄ (146)
Effective Embedment Depth	h_{ef}	in. (mm)	¹ / ₂ (38)	¹ / ₂ (38)	² / ₂ (64)	² / ₄ (57)	³ / ₈ (86)	² / ₄ (70)	⁴ / ₂ (114)	³ / ₈ (86)	5 (127)
Minimum Hole Depth	h_{hole}	in. (mm)	¹ / ₂ (48)	2 (51)	3 (76)	3 (76)	⁴ / ₈ (105)	⁵ / ₈ (92)	⁵ / ₈ (137)	⁴ / ₈ (111)	6 (152)
Minimum Overall Anchor Length	λ_{anch}	in. (mm)	² / ₄ (57)	² / ₄ (70)	³ / ₂ (89)	³ / ₄ (95)	⁵ / ₂ (140)	⁴ / ₂ (114)	6 (152)	⁵ / ₂ (140)	7 (178)
Critical Edge Distance	c_{ac}	in. (mm)	² / ₂ (64)	⁶ / ₂ (165)	⁸ / ₂ (216)	⁴ / ₂ (114)	7 (178)	⁷ / ₂ (191)	9 (229)	8 (203)	8 (203)
Minimum Edge Distance	c_{min}	in. (mm)	³ / ₄ (45)	6 (152)	⁶ / ₂ (165)	5 (127)	4 (102)	4 (102)	6 (152)	6 (152)	6 (152)
	for $s \geq$	in. (mm)	- -	10 (254)	- -	- -	8 (203)	8 (203)	- -	- -	- -
Minimum Spacing	s_{min}	in. (mm)	² / ₄ (57)	3 (76)	8 (203)	⁵ / ₂ (140)	4 (102)	⁶ / ₄ (159)	⁶ / ₂ (165)	⁶ / ₂ (165)	⁶ / ₂ (165)
	for $c \geq$	in. (mm)	- -	10 (254)	- -	- -	8 (203)	⁵ / ₂ (140)	- -	- -	- -
Minimum Concrete Thickness	h_{min}	in. (mm)	³ / ₄ (83)	³ / ₄ (83)	⁴ / ₂ (114)	⁴ / ₂ (114)	6 (152)	⁵ / ₂ (140)	⁷ / ₈ (200)	⁶ / ₄ (172)	⁸ / ₄ (222)
Additional Data											
Specified Yield Strength	f_{ya}	psi (MPa)	96,000 (662)	80,000 (552)	92,000 (634)	82,000 (565)	68,000 (469)				
Specified Tensile Strength	f_{uta}	psi (MPa)	120,000 (827)	100,000 (689)	115,000 (793)	108,000 (745)	95,000 (655)				
Minimum Tensile and Shear Stress Area	A_{se}^3	in ² (mm ²)	0.0255 (16)	0.0514 (33)	0.105 (68)	0.166 (107)	0.270 (174)				
Axial Stiffness in Service Load Range - Cracked and Uncracked Concrete ⁴	β	lb./in (N/mm)	54,430 ⁴ (9,525) ⁴	29,150 (5,105)	54,900 (9,614)	61,270 (10,730)	154,290 (27,020)				

For SI: 1 inch = 25.4 mm, 1 ft-lbf = 1.356 N-m, 1 psi = 6.89 Pa, 1 in² = 645 mm², 1 lbf/in = 0.175 N/mm.

¹The information presented in this table is to be used in conjunction with the design criteria of ACI 318-14 Chapter 17 or ACI 318-11 Appendix D, as applicable.

²The clearance must comply with applicable code requirements for the connected element.

³For the 2006 IBC d_o replaces d_a , $A_{se,N}$ replaces A_{se} .

⁴The tabulated value of β for ¹/₄-inch-diameter stainless steel Strong-Bolt® 2 anchor is for installations in uncracked concrete only.

⁵The ¹/₄-inch-diameter (6.4 mm) anchor may be installed in top of uncracked normal-weight and sand-lightweight concrete over profile steel deck where concrete thickness above upper flute meets the minimum thicknesses specified in this table.

⁶The ³/₈-inch- through ³/₄-inch-diameter (9.5 mm through 19.1 mm) anchors may be installed in top of cracked and uncracked normal-weight and sand-lightweight concrete over profile steel deck where concrete thickness above upper flute meets the minimum thicknesses specified in this table, and Tables 5A and 5B for the ³/₈-inch and ¹/₂-inch-diameter (9.5 mm and 12.7 mm) anchors.

TABLE 2A—CARBON STEEL STRONG-BOLT® 2 ANCHOR TENSION STRENGTH DESIGN DATA¹

CHARACTERISTIC	SYMBOL	UNITS	NOMINAL ANCHOR DIAMETER										
			Carbon Steel										
			1/4 inch ⁸	3/8 inch ⁹	1/2 inch ⁹	5/8 inch ⁹	3/4 inch ⁹	1 inch ⁹					
Anchor Category	1,2 or 3	-	1									2	
Nominal Embedment Depth	h_{nom}	in. (mm)	1 ^{3/4} (45)	1 ^{7/8} (48)	2 ^{7/8} (73)	2 ^{3/4} (70)	3 ^{7/8} (98)	3 ^{3/8} (86)	5 ^{1/8} (130)	4 ^{1/8} (105)	5 ^{3/4} (146)	5 ^{1/4} (133)	9 ^{3/4} (248)
Steel Strength in Tension (ACI 318-14 Section 17.4.1 or ACI 318-11 Section D.5.1)													
Steel Strength in Tension	N_{sa}	lb (kN)	2,225 (9.9)	5,600 (24.9)	12,100 (53.8)	19,070 (84.8)	29,700 (132.1)	36,815 (163.8)					
Strength Reduction Factor - Steel Failure ²	ϕ_{sa}	-	0.75									0.65	
Concrete Breakout Strength in Tension (ACI 318-14 Section 17.4.2 or ACI 318-11 Section D.5.2)													
Effective Embedment Depth	h_{ef}	in. (mm)	1 ^{1/2} (38)	1 ^{1/2} (38)	2 ^{1/2} (64)	2 ^{1/4} (57)	3 ^{3/8} (86)	2 ^{3/4} (70)	4 ^{1/2} (114)	3 ^{3/8} (86)	5 (127)	4 ^{1/2} (114)	9 (229)
Critical Edge Distance	c_{ac}	in. (mm)	2 ^{1/2} (64)	6 ^{1/2} (165)	6 (152)	6 ^{1/2} (165)	7 ^{1/2} (191)	7 ^{1/2} (191)	9 (229)	9 (229)	8 (203)	18 (457)	13 ^{1/2} (343)
Effectiveness Factor - Uncracked Concrete	k_{uncr}	-	24	24	24	24	24	24	24	24	24	24	24
Effectiveness Factor - Cracked Concrete	k_{cr}	-	See Note 7	17	17	17	17	17	17	17	17	17	17
Modification Factor	$\psi_{c,N}$	-	See Note 7	1.00	1.00	1.00	1.00	1.00	1.00	1.00	1.00	1.00	1.00
Strength Reduction Factor - Concrete Breakout Failure ³	ϕ_{cb}	-	0.65									0.55	
Pull-Out Strength in Tension (ACI 318-14 17.4.3.1 or ACI 318-11 Section D.5.3)													
Pull-Out Strength Cracked Concrete ($f'_c = 2500$ psi)	$N_{p,cr}$	lb (kN)	See Note 7 -	1,300 ⁵ (5.8) ⁵	2,775 ⁵ (12.3) ⁵	N/A ⁴ -	3,735 ⁵ (16.6) ⁵	N/A ⁴ -	6,895 ⁵ (30.7) ⁵	N/A ⁴ -	8,500 ⁵ (37.8) ⁵	7,700 ⁵ (34.3) ⁵	11,185 ⁵ (49.8) ⁵
Pull-Out Strength Uncracked Concrete ($f'_c = 2500$ psi)	$N_{p,uncr}$	lb (kN)	N/A ⁴ -	N/A ⁴ -	3,340 ⁵ (14.9) ⁵	3,615 ⁵ (16.1) ⁵	5,255 ⁵ (23.4) ⁵	N/A ⁴ -	9,025 ⁵ (40.1) ⁵	7,115 ⁵ (31.6) ⁵	8,870 ⁵ (39.5) ⁵	8,360 ⁵ (37.2) ⁵	9,690 ⁵ (43.1) ⁵
Strength Reduction Factor - Pullout Failure ⁵	ϕ_p	-	0.65									0.55	
Tensile Strength for Seismic Applications (ACI 318-14 17.2.3.3 or ACI 318-11 Section D.3.3.3)													
Tension Resistance of Single Anchor for Seismic Loads ($f'_c = 2500$ psi)	$N_{p,eq}$	lb (kN)	See Note 7 -	1,300 ⁵ (5.8) ⁵	2,775 ⁵ (12.3) ⁵	N/A ⁴ -	3,735 ⁵ (16.6) ⁵	N/A ⁴ -	6,895 ⁵ (30.7) ⁵	N/A ⁴ -	8,500 ⁵ (37.8) ⁵	7,700 ⁵ (34.3) ⁵	11,185 ⁵ (49.8) ⁵
Strength Reduction Factor - Pullout Failure ⁵	ϕ_{eq}	-	0.65									0.55	

For SI: 1 inch = 25.4 mm, 1 lbf = 4.45 N.

¹The information presented in this table must be used in conjunction with the design criteria of ACI 318-14 Chapter 17 or ACI 318-11 Appendix D, as applicable.

²The tabulated value of ϕ_{sa} applies when the load combinations of Section 1605.2 of the IBC, ACI 318-14 Section 5.3 or ACI 318-11 Section 9.2 are used. If the load combinations of ACI 318-11 Appendix C are used, the appropriate value of ϕ_{sa} must be determined in accordance with ACI 318-11 D.4.4. The 3/8-inch-, 1/2-inch-, 5/8-inch- and 3/4-inch-diameter carbon steel Strong-Bolt® 2 anchors are ductile steel elements as defined in ACI 318-14 2.3 or ACI 318-11 D.1, as applicable. The 1-inch-diameter carbon steel Strong-Bolt® 2 anchor is a brittle steel element as defined in ACI 318-14 2.3 or ACI 318-11 D.1, as applicable.

³The tabulated value of ϕ_{cb} applies when both the load combinations of Section 1605.2 of the IBC, ACI 318-14 Section 5.3 or ACI 318-11 Section 9.2 are used and the requirements of ACI 318-14 17.3.3(c) or ACI 318-11 D.4.3(c), as applicable, for Condition B are met. Condition B applies where supplementary reinforcement is not provided. For installations where complying supplementary reinforcement can be verified, the ϕ_{cb} factors described in ACI 318-14 17.3.3(c) or ACI 318-11 D.4.3(c), as applicable, for Condition A are allowed. If the load combinations of ACI 318-11 Appendix C are used, the appropriate value of ϕ_{cb} must be determined in accordance with ACI 318-11 D.4.4(c).

⁴As described in Section 4.1.4 of this report, N/A (Not Applicable) denotes that pullout resistance does not need to be considered.

⁵The characteristic pull-out strength for greater concrete compressive strengths must be increased by multiplying the tabular value by $(f'_c / 2,500 \text{ psi})^{0.5}$ or $(f'_c / 17.2 \text{ MPa})^{0.5}$.

⁶The tabulated value of ϕ_p or ϕ_{eq} applies when the load combinations of IBC Section 1605.2, ACI 318-14 Section 5.3 or ACI 318-11 Section 9.2, as applicable, are used and the requirements of ACI 318-14 17.3.3(c) or ACI 318-11 D.4.3(c) for Condition B are met. For installations where complying supplementary reinforcement can be verified, the ϕ_p or ϕ_{eq} factors described in ACI 318-14 17.3.3(c) or ACI 318-11 D.4.3(c), as applicable, for Condition A are allowed. If the load combinations of ACI 318-11 Appendix C are used, appropriate value of ϕ must be determined in accordance with ACI 318-11 D.4.4(c).

⁷The 1/4-inch-diameter carbon steel Strong-Bolt® 2 anchor installation in cracked concrete is beyond the scope of this report.

⁸The 1/4-inch-diameter (6.4 mm) anchor may be installed in top of uncracked normal-weight and sand-lightweight concrete over profile steel deck where concrete thickness above upper flute meets the minimum thicknesses specified in Table 1A.

⁹The 3/8-inch- through 1-inch-diameter (9.5 mm through 25.4 mm) anchors may be installed in top of cracked and uncracked normal-weight and sand-lightweight concrete over profile steel deck where concrete thickness above upper flute meets the minimum thicknesses specified in Table 1A, and Tables 5A and 5B for the 3/8-inch and 1/2-inch-diameter (9.5 mm and 12.7 mm) anchors.

TABLE 2B—STAINLESS STEEL STRONG-BOLT® 2 ANCHOR TENSION STRENGTH DESIGN DATA¹

CHARACTERISTIC	SYMBOL	UNITS	NOMINAL ANCHOR DIAMETER								
			Stainless Steel								
			1/4 inch ¹⁰	3/8 inch ¹¹	1/2 inch ¹¹	5/8 inch ¹¹	3/4 inch ¹¹				
Anchor Category	1, 2 or 3	-	1								
Nominal Embedment Depth	h_{nom}	in. (mm)	1 ^{3/4} (45)	1 ^{7/8} (48)	2 ^{7/8} (73)	2 ^{3/4} (70)	3 ^{7/8} (98)	3 ^{3/8} (86)	5 ^{1/8} (130)	4 ^{1/8} (105)	5 ^{3/4} (146)
Steel Strength in Tension (ACI 318-14 17.4.1 or ACI 318-11 Section D.5.1)											
Steel Strength in Tension	N_{sa}	Lb (kN)	3,060 (13.6)	5,140 (22.9)	12,075 (53.7)	17,930 (79.8)	25,650 (114.1)				
Strength Reduction Factor - Steel Failure ²	ϕ_{sa}	-	0.75								
Concrete Breakout Strength in Tension (ACI 318-14 17.4.2 or ACI 318-11 Section D.5.2)											
Effective Embedment Depth	h_{ef}	in. (mm)	1 ^{1/2} (38)	1 ^{1/2} (38)	2 ^{1/2} (64)	2 ^{1/4} (57)	3 ^{3/8} (86)	2 ^{3/4} (70)	4 ^{1/2} (114)	3 ^{3/8} (86)	5 (127)
Critical Edge Distance	c_{ac}	in. (mm)	2 ^{1/2} (64)	6 ^{1/2} (165)	8 ^{1/2} (216)	4 ^{1/2} (114)	7 (178)	7 ^{1/2} (191)	9 (229)	8 (203)	8 (203)
Effectiveness Factor - Uncracked Concrete	k_{uncr}	-	24	24	24	24	24	24	24	24	24
Effectiveness Factor - Cracked Concrete	k_{cr}	-	See Note 9	17	17	17	17	17	17	17	17
Modification Factor	$\psi_{c,N}$	-	See Note 9	1.00	1.00	1.00	1.00	1.00	1.00	1.00	1.00
Strength Reduction Factor - Concrete Breakout Failure ³	ϕ_{cb}	-	0.65								
Pull-Out Strength in Tension (ACI 318-14 17.4.3 or ACI 318-11 Section D.5.3)											
Pull-Out Strength Cracked Concrete ($f'_c = 2500$ psi)	$N_{p,cr}$	Lb (kN)	See Note 9 -	1,720 ⁶ (7.7) ⁶	3,145 ⁶ (14.0) ⁶	2,560 ⁵ (11.4) ⁵	4,305 ⁵ (19.1) ⁵	N/A ⁴ -	6,545 ⁷ (29.1) ⁷	N/A ⁴ -	8,230 ⁵ (36.6) ⁵
Pullout Strength Uncracked Concrete ($f'_c = 2500$ psi)	$N_{p,uncr}$	Lb (kN)	1,925 ⁷ (8.6) ⁷	N/A ⁴ -	4,770 ⁶ (21.2) ⁶	3,230 ⁵ (14.4) ⁵	4,495 ⁵ (20.0) ⁵	N/A ⁴ -	7,615 ⁵ (33.9) ⁵	7,725 ⁷ (34.4) ⁷	9,625 ⁷ (42.8) ⁷
Strength Reduction Factor - Pullout Failure ⁸	ϕ_p	-	0.65								
Tensile Strength for Seismic Applications (ACI 318 17.2.3.3 or ACI 318-11 Section D.3.3.3)											
Tension Resistance of Single Anchor for Seismic Loads ($f'_c = 2500$ psi)	$N_{p,eq}$	Lb (kN)	See Note 9 -	1,720 ⁶ (7.7) ⁶	2,830 ⁶ (12.6) ⁶	2,560 ⁵ (11.4) ⁵	4,305 ⁵ (19.1) ⁵	N/A ⁴ -	6,545 ⁷ (29.1) ⁷	N/A ⁴ -	8,230 ⁵ (36.6) ⁵
Strength Reduction Factor - Pullout Failure ⁸	ϕ_{eq}	-	0.65								

For SI: 1 inch = 25.4 mm, 1 lbf = 4.45 N.

¹The information presented in this table must be used in conjunction with the design criteria of ACI 318-14 Chapter 17 or ACI 318-11 Appendix D, as applicable.

²The tabulated value of ϕ_{sa} applies when the load combinations of Section 1605.2 of the IBC, ACI 318-14 Section 5.3 or ACI 318-11 Section 9.2 are used. If the load combinations of ACI 318-11 Appendix C are used, the appropriate value of ϕ_{sa} must be determined in accordance with ACI 318-11 D.4.4. The stainless steel Strong-Bolt® 2 anchors are ductile steel elements as defined in ACI 318-14 2.3 or ACI 318-11 D.1, as applicable.

³The tabulated value of ϕ_{cb} applies when both the load combinations of Section 1605.2 of the IBC, ACI 318-14 Section 5.3 or ACI 318-11 Section 9.2 are used and the requirements of ACI 318-14 17.3.3(c) or ACI 318-11 D.4.3(c), as applicable, for Condition B are met. Condition B applies where supplementary reinforcement is not provided. For installations where complying supplementary reinforcement can be verified, the ϕ_{cb} factors described in ACI 318-14 17.3.3(c) or ACI 318-11 D.4.3(c), as applicable, for Condition A are allowed. If the load combinations of ACI 318-11 Appendix C are used, the appropriate value of ϕ_{cb} must be determined in accordance with ACI 318-11 D.4.4(c).

⁴As described in Section 4.1.4 of this report, N/A (Not Applicable) denotes that pullout resistance does not need to be considered.

⁵The characteristic pull-out strength for greater concrete compressive strengths must be increased by multiplying by $(\frac{f'_c}{2,500\text{psi}})^{0.5}$ or $(\frac{f'_c}{17.2\text{MPa}})^{0.5}$.

⁶The characteristic pull-out strength for greater concrete compressive strengths must be increased by multiplying by $(\frac{f'_c}{2,500\text{psi}})^{0.3}$ or $(\frac{f'_c}{17.2\text{MPa}})^{0.3}$.

⁷The characteristic pull-out strength for greater concrete compressive strengths must be increased by multiplying by $(\frac{f'_c}{2,500\text{psi}})^{0.4}$ or $(\frac{f'_c}{17.2\text{MPa}})^{0.4}$.

⁸The tabulated value of ϕ_p or ϕ_{eq} applies when the load combinations of IBC Section 1605.2.1, ACI 318-14 Section 5.3 or ACI 318-11 Section 9.2 are used and the requirements of ACI 318-14 17.3.3(c) or ACI 318-11 D.4.3(c), as applicable, for Condition B are met. For installations where complying supplementary reinforcement can be verified, the ϕ_p or ϕ_{eq} factors described in ACI 318-14 17.3.3(c) or ACI 318-11 D.4.3(c), as applicable, for Condition A are allowed. If the load combinations of ACI 318-11 Appendix C are used, appropriate value of ϕ must be determined in accordance with ACI 318-11 D.4.4(c).

⁹The 1/4-inch-diameter stainless steel Strong-Bolt® 2 anchor installation in cracked concrete is beyond the scope of this report.

¹⁰The 1/4-inch-diameter (6.4 mm) anchor may be installed in top of uncracked normal-weight and sand-lightweight concrete over profile steel deck where concrete thickness above upper flute meets the minimum thicknesses specified in Table 1B.

¹¹The 3/8-inch- through 3/4-inch-diameter (9.5 mm through 19.1 mm) anchors may be installed in top of cracked and uncracked normal-weight and sand-lightweight concrete over profile steel deck where concrete thickness above upper flute meets the minimum thicknesses specified in Table 1B, and Tables 5A and 5B for the 3/8-inch and 1/2-inch-diameter (9.5 mm and 12.7 mm) anchors.

TABLE 3A—CARBON STEEL STRONG-BOLT® 2 ANCHOR SHEAR STRENGTH DESIGN DATA¹

CHARACTERISTIC	SYMBOL	UNITS	NOMINAL ANCHOR DIAMETER										
			Carbon Steel										
			¹ / ₄ inch ⁷	³ / ₈ inch ⁸	¹ / ₂ inch ⁸	⁵ / ₈ inch ⁸	³ / ₄ inch ⁸	1 inch ⁸					
Anchor Category	1,2 or 3	-	1									2	
Nominal Embedment Depth	h_{nom}	in. (mm)	¹ / ₄ (45)	³ / ₈ (48)	¹ / ₂ (73)	⁵ / ₈ (70)	³ / ₄ (98)	⁷ / ₈ (86)	1 (130)	¹ / ₂ (105)	³ / ₄ (146)	¹ / ₂ (133)	³ / ₄ (248)
Steel Strength in Shear (ACI 318-14 17.5.1.1 or ACI 318-11 Section D.6.1)													
Shear Resistance of Steel	V_{sa}	Lb (kN)	965 (4.3)	1,800 (8.0)	7,235 (32.2)	11,035 (49.1)	14,480 (64.4)	15,020 (66.8)					
Strength Reduction Factor - Steel Failure ²	ϕ_{sa}	-	0.65									0.60	
Concrete Breakout Strength in Shear (ACI 318-14 17.5.2 or ACI 318-11 Section D.6.2)													
Outside Diameter	d_a^5	in. (mm)	0.250 (6.4)	0.375 (9.5)	0.500 (12.7)	0.625 (15.9)	0.750 (19.1)	1.000 (25.4)					
Load Bearing Length of Anchor in Shear	λ_e	in. (mm)	1.500 (38)	1.500 (38)	2.500 (64)	2.250 (57)	3.375 (86)	2.750 (70)	4.500 (114)	3.375 (86)	5.000 (127)	4.500 (114)	8.000 (203)
Strength Reduction Factor - Concrete Breakout Failure ³	ϕ_{cb}	-	0.70										
Concrete Pryout Strength in Shear (ACI 318-14 17.5.3 or ACI 318-11 Section D.6.3)													
Coefficient for Pryout Strength	k_{cp}	-	1.0	1.0	2.0	1.0	2.0	2.0	2.0	2.0	2.0	2.0	2.0
Effective Embedment Depth	h_{ef}	in. (mm)	1 ¹ / ₂ (38)	1 ¹ / ₂ (38)	2 ¹ / ₂ (64)	2 ¹ / ₄ (57)	3 ³ / ₈ (86)	2 ³ / ₄ (70)	4 ¹ / ₂ (114)	3 ³ / ₈ (86)	5 (127)	4 ¹ / ₂ (114)	9 (229)
Strength Reduction Factor - Concrete Pryout Failure ⁴	ϕ_{cp}	-	0.70										
Steel Strength in Shear for Seismic Applications (ACI 318-14 17.2.3.3 or ACI 318-11 Section D.3.3.3)													
Shear Strength of Single Anchor for Seismic Loads ($f'_c = 2500$ psi)	$V_{sa,eq}$	Lb (kN)	See Note 6 -	1,800 (8.0)	6,510 (29.0)	9,930 (44.2)	11,775 (52.4)	15,020 (66.8)					
Strength Reduction Factor - Steel Failure ²	ϕ_{sa}	-	0.65									0.60	

For SI: 1 inch = 25.4 mm, 1 lbf = 4.45 N.

¹The information presented in this table must be used in conjunction with the design criteria of ACI 318-14 Chapter 17 or ACI 318-11 Appendix D, as applicable.

²The tabulated value of ϕ_{sa} applies when the load combinations of Section 1605.2 of the IBC, ACI 318-14 Section 5.3 or ACI 318-11 Section 9.2 are used. If the load combinations of or ACI 318-11 Appendix C are used, the appropriate value of ϕ_{sa} must be determined in accordance with ACI 318-11 D.4.4. The ³/₈-inch-, ¹/₂-inch-, ⁵/₈-inch- and ³/₄-inch-diameter carbon steel Strong-Bolt® 2 anchors are ductile steel elements as defined in ACI 318-14 2.3 or ACI 318-11 D.1, as applicable. The 1-inch-diameter carbon steel Strong-Bolt® 2 anchor is a brittle steel element as defined in ACI 318-14 2.3 or ACI 318-11 D.1, as applicable.

³The tabulated value of ϕ_{cb} applies when both the load combinations of Section 1605.2 of the IBC, ACI 318-14 Section 5.3 or ACI 318-11 Section 9.2, as applicable, are used and the requirements of ACI 318-14 17.3.3(c) or ACI 318-11 D.4.3(c) for Condition B are met. Condition B applies where supplementary reinforcement is not provided. For installations where complying supplementary reinforcement can be verified, the ϕ_{cb} factors described in ACI 318-14 17.3.3(c) or ACI 318-11 D.4.3(c), as applicable, for Condition A are allowed. If the load combinations of ACI 318-11 Appendix C are used, the appropriate value of ϕ_{cb} must be determined in accordance with ACI 318-11 D.4.4(c).

⁴The tabulated value of ϕ_{cp} applies when the load combinations of IBC Section 1605.2, ACI 318-14 5.3 or ACI 318-11 9.2 are used and the requirements of ACI 318-14 17.3.3(c) or ACI 318-11 D.4.3(c) for Condition B are met. For installations where complying supplementary reinforcement can be verified, the ϕ_{cp} factors described in ACI 318-14 17.3.3(c) or ACI 318-11 D.4.3(c), as applicable, for Condition A are allowed. If the load combinations of ACI 318-11 Appendix C are used, the appropriate value of ϕ_{cp} must be determined in accordance with ACI 318-11 D.4.4(c).

⁵For the 2006 IBC d_o replaces d_a .

⁶The ¹/₄-inch-diameter carbon steel Strong-Bolt® 2 anchor installation in cracked concrete is beyond the scope of this report.

⁷The ¹/₄-inch-diameter (6.4 mm) anchor may be installed in the top of uncracked normal-weight and sand-lightweight concrete over profile steel deck where concrete thickness above upper flute meets the minimum thicknesses specified in [Table 1A](#).

⁸The ³/₈-inch- through 1-inch-diameter (9.5 mm through 25.4 mm) anchors may be installed in the top of cracked and uncracked normal-weight and sand-lightweight concrete over profile steel deck where concrete thickness above upper flute meets the minimum thicknesses specified in [Table 1A](#), and Tables 5A and 5B for the ³/₈-inch and ¹/₂-inch-diameter (9.5 mm and 12.7 mm) anchors.

TABLE 3B—STAINLESS STEEL STRONG-BOLT® 2 ANCHOR SHEAR STRENGTH DESIGN DATA¹

CHARACTERISTIC	SYMBOL	UNITS	NOMINAL ANCHOR DIAMETER								
			Stainless Steel								
			¹ / ₄ inch ⁷	³ / ₈ inch ⁸	¹ / ₂ inch ⁸	⁵ / ₈ inch ⁸	³ / ₄ inch ⁸				
Anchor Category	1,2 or 3	-	1								
Nominal Embedment Depth	h_{nom}	in. (mm)	¹ / ₄ (45)	¹ / ₈ (48)	² / ₈ (73)	² / ₄ (70)	³ / ₈ (98)	³ / ₈ (86)	⁵ / ₈ (130)	⁴ / ₈ (105)	⁵ / ₄ (146)
Steel Strength in Shear (ACI 318-14 17.5.1 or ACI 318-11 Section D.6.1)											
Shear Resistance of Steel	V_{sa}	Lb (kN)	1,605 (7.1)	3,085 (13.7)	7,245 (32.2)		6,745 (30.0)	10,760 (47.9)	15,045 (66.9)		
Strength Reduction Factor - Steel Failure ²	ϕ_{sa}	-	0.65								
Concrete Breakout Strength in Shear (ACI 318-14 17.5.2 or ACI 318-11 Section D.6.2)											
Outside Diameter	d_a ⁵	in. (mm)	0.250 (6.4)	0.375 (9.5)	0.500 (12.7)		0.625 (15.9)	0.750 (19.1)			
Load Bearing Length of Anchor in Shear	λ_e	in. (mm)	1.500 (38)	1.500 (38)	2.500 (64)	2.250 (57)	3.375 (86)	2.750 (70)	4.500 (114)	3.375 (86)	5.000 (127)
Strength Reduction Factor - Concrete Breakout Failure ³	ϕ_{cb}	-	0.70								
Concrete Pryout Strength in Shear (ACI 318-14 17.5.2 or ACI 318-11 Section D.6.3)											
Coefficient for Pryout Strength	k_{cp}	-	1.0	1.0	2.0	1.0	2.0	2.0		2.0	
Effective Embedment Depth	h_{ef}	in. (mm)	¹ / ₂ (38)	¹ / ₂ (38)	² / ₂ (64)	² / ₄ (57)	³ / ₈ (86)	² / ₄ (70)	⁴ / ₂ (114)	³ / ₈ (86)	5 (127)
Strength Reduction Factor - Concrete Pryout Failure ⁴	ϕ_{cp}	-	0.70								
Steel Strength in Shear for Seismic Applications (ACI 318-14 17.2.3.3 or ACI 318-11 Section D.3.3.3)											
Shear Strength of Single Anchor for Seismic Loads ($f'_c = 2500$ psi)	$V_{sa,eq}$	Lb (kN)	See Note 6 -	3,085 (13.7)	6,100 (27.1)		6,745 (30.0)	10,760 (47.9)	13,620 (60.6)		
Strength Reduction Factor - Steel Failure ²	ϕ_{sa}	-	0.65								

For **SI**: 1 inch = 25.4 mm, 1 lbf = 4.45 N.

¹The information presented in this table must be used in conjunction with the design criteria of ACI 318-14 Chapter 17 or ACI 318-11 Appendix D.

²The tabulated value of ϕ_{sa} applies when the load combinations of Section 1605.2 of the IBC, ACI 318-14 Section 5.3 or ACI 318-11 Section 9.2, as applicable, are used. If the load combinations of or ACI 318-11 Appendix C are used, the appropriate value of ϕ_{sa} must be determined in accordance with ACI 318-11 D.4.4. The stainless steel Strong-Bolt® 2 anchors are ductile steel elements as defined in ACI 318-14 2.3 or ACI 318-11 D.1, as applicable.

³The tabulated value of ϕ_{cb} applies when both the load combinations of Section 1605.2 of the IBC, ACI 318-14 Section 5.3 or ACI 318-11 Section 9.2, as applicable, are used and the requirements of ACI 318-14 17.3.3(c) or ACI 318-11 D.4.3(c) for Condition B are met. Condition B applies where supplementary reinforcement is not provided. For installations where complying supplementary reinforcement can be verified, the ϕ_{cb} factors described in ACI 318-14 17.3.3 or ACI 318-11 D.4.3, as applicable, for Condition A are allowed. If the load combinations of ACI 318-11 Appendix C are used, the appropriate value of ϕ_{cb} must be determined in accordance with ACI 318-11 D.4.4(c).

⁴The tabulated value of ϕ_{cp} applies when the load combinations of IBC Section 1605.2, ACI 318-14 5.3 or ACI 318-11 9.2, as applicable, are used and the requirements of ACI 318-14 17.3.3(c) or ACI 318-11 D.4.3(c) for Condition B are met. For installations where complying supplementary reinforcement can be verified, the ϕ_{cp} factors described in ACI 318-14 17.3.3 or ACI 318-11 D.4.3, as applicable, for Condition A are allowed. If the load combinations of ACI 318-11 Appendix C are used, the appropriate value of ϕ_{cp} must be determined in accordance with ACI 318-11 D.4.4(c).

⁵For the 2006 IBC d_o replaces d_a .

⁶The ¹/₄-inch-diameter stainless steel Strong-Bolt® 2 anchor installation in cracked concrete is beyond the scope of this report.

⁷The ¹/₄-inch-diameter (6.4 mm) anchor may be installed in the top of uncracked normal-weight and sand-lightweight concrete over profile steel deck where concrete thickness above upper flute meets the minimum thicknesses specified in [Table 1B](#).

⁸The ³/₈-inch- through ³/₄-inch-diameter (9.5 mm through 19.1 mm) anchors may be installed in the top of cracked and uncracked normal-weight and sand-lightweight concrete over profile steel deck where concrete thickness above upper flute meets the minimum thicknesses specified in [Table 1B](#), and Tables 5A and 5B for the ³/₈-inch and ¹/₂-inch-diameter (9.5 mm and 12.7 mm) anchors.

TABLE 4A—CARBON STEEL STRONG-BOLT® 2 ANCHOR TENSION AND SHEAR STRENGTH DESIGN DATA FOR THE SOFFIT OF CONCRETE OVER PROFILE STEEL DECK, FLOOR AND ROOF ASSEMBLIES^{1,2,6,8}

CHARACTERISTIC	SYMBOL	UNITS	NOMINAL ANCHOR DIAMETER								
			Lower Flute						Upper Flute		
			3/8 inch		1/2 inch		5/8 inch		3/4 inch	3/8 inch	1/2 inch
Nominal Embedment Depth	h_{nom}	in. (mm)	2 (51)	3 ^{3/8} (86)	2 ^{3/4} (70)	4 ^{1/2} (114)	3 ^{3/8} (86)	5 ^{5/8} (143)	4 ^{1/8} (105)	2 (51)	2 ^{3/4} (70)
Effective Embedment Depth	h_{ef}	in. (mm)	1 ^{5/8} (41)	3 (76)	2 ^{1/4} (57)	4 (102)	2 ^{3/4} (70)	5 (127)	3 ^{3/8} (86)	1 ^{5/8} (41)	2 ^{1/4} (57)
Minimum Hole Depth	h_{hole}	in. (mm)	2 ^{1/8} (54)	3 ^{1/2} (89)	3 (76)	4 ^{3/4} (121)	3 ^{5/8} (92)	5 ^{7/8} (149)	4 ^{3/8} (111)	2 ^{1/8} (54)	3 (76)
Installation Torque	T_{inst}	ft-lbf (N-m)	30 (40.7)		60 (81.3)		90 (122.0)		150 (203.4)	30 (40.7)	60 (81.3)
Pullout Strength, concrete on metal deck (cracked) ³	$N_{p,deck,cr}$	Lb (kN)	1,040 ⁷ (4.6) ⁷	2,615 ⁷ (11.6) ⁷	2,040 ⁷ (9.1) ⁷	2,730 ⁷ (12.1) ⁷	2,615 ⁷ (11.6) ⁷	4,990 ⁷ (22.2) ⁷	2,815 ⁷ (12.5) ⁷	1,340 ⁷ (6.0) ⁷	3,785 ⁷ (16.8) ⁷
Pullout Strength, concrete on metal deck (uncracked) ³	$N_{p,deck,uncr}$	Lb (kN)	1,765 ⁷ (7.9) ⁷	3,150 ⁷ (14.0) ⁷	2,580 ⁷ (11.5) ⁷	3,840 ⁷ (17.1) ⁷	3,685 ⁷ (16.4) ⁷	6,565 ⁷ (29.2) ⁷	3,800 ⁷ (16.9) ⁷	2,275 ⁷ (10.1) ⁷	4,795 ⁷ (21.3) ⁷
Pullout Strength, concrete on metal deck (Seismic) ⁵	$N_{p,deck,eq}$	Lb (kN)	1,040 ⁷ (4.6) ⁷	2,615 ⁷ (11.6) ⁷	2,040 ⁷ (9.1) ⁷	2,730 ⁷ (12.1) ⁷	2,615 ⁷ (11.6) ⁷	4,990 ⁷ (22.2) ⁷	2,815 ⁷ (12.5) ⁷	1,340 ⁷ (6.0) ⁷	3,785 ⁷ (16.8) ⁷
Steel Strength in Shear, concrete on metal deck ⁴	$V_{sa,deck}$	Lb (kN)	1,595 (7.1)	3,490 (15.5)	2,135 (9.5)	4,580 (20.4)	2,640 (11.7)	7,000 (31.1)	4,535 (20.2)	3,545 (15.8)	5,920 (26.3)
Steel Strength in Shear, concrete on metal deck (Seismic) ⁵	$V_{sa,deck,eq}$	Lb (kN)	1,595 (7.1)	3,490 (15.5)	1,920 (8.5)	4,120 (18.3)	2,375 (10.6)	6,300 (28.0)	3,690 (16.4)	3,545 (15.8)	5,330 (23.7)

For SI: 1 inch = 25.4 mm, 1 lbf = 4.45 N.

¹Installation must comply with Section 4.3 and Figure 4.

²Profile steel deck must comply with Figure 4 and Section 3.3 of this report.

³The values must be used in accordance with Section 4.1.4 of this report.

⁴The values must be used in accordance with Section 4.1.5 of this report.

⁵The values must be used in accordance with Section 4.1.8 of this report.

⁶The minimum anchor spacing along the flute must be the greater of $3h_{ef}$ or 1.5 times the flute width.

⁷The characteristic pull-out strength for greater concrete compressive strengths must be increased by multiplying the tabular value by $(f'_c / 3,000\text{psi})^{0.5}$ or $(f'_c / 20.7\text{MPa})^{0.5}$.

⁸Concrete shall be normal-weight or sand-lightweight concrete having a minimum specified compressive strength, f'_c , of 3,000 psi (20.7 MPa).

TABLE 4B—STAINLESS STEEL STRONG-BOLT® 2 ANCHOR TENSION AND SHEAR STRENGTH DESIGN DATA FOR THE SOFFIT OF CONCRETE OVER PROFILE STEEL DECK, FLOOR AND ROOF ASSEMBLIES^{1,2,6,10}

CHARACTERISTIC	SYMBOL	UNITS	NOMINAL ANCHOR DIAMETER								
			Lower Flute						Upper Flute		
			³ / ₈ inch		¹ / ₂ inch		⁵ / ₈ inch		³ / ₄ inch	³ / ₈ inch	¹ / ₂ inch
Nominal Embedment Depth	h_{nom}	in. (mm)	2 (51)	³ / ₈ (86)	² / ₄ (70)	⁴ / ₂ (114)	³ / ₈ (86)	⁵ / ₈ (143)	⁴ / ₈ (105)	2 (51)	² / ₄ (70)
Effective Embedment Depth	h_{ef}	in. (mm)	¹ / ₈ ⁵ (41)	3 (76)	² / ₄ ¹ (57)	4 (102)	² / ₄ ³ (70)	5 (127)	³ / ₈ ³ (86)	¹ / ₈ ⁵ (41)	² / ₄ ¹ (57)
Minimum Hole Depth	h_{hole}	in. (mm)	² / ₈ ¹ (54)	³ / ₂ ¹ (89)	3 (76)	⁴ / ₄ ³ (121)	⁵ / ₈ ³ (92)	⁷ / ₈ ⁵ (149)	⁴ / ₈ ³ (111)	² / ₈ ¹ (54)	3 (76)
Installation Torque	T_{inst}	ft-lbf (N-m)	30 (40.7)		60 (81.3)		80 (108.5)		150 (203.4)	30 (40.7)	60 (81.3)
Pullout Strength, concrete on metal deck (cracked) ³	$N_{p,deck,cr}$	Lb (kN)	1,230 ⁸ (5.5) ⁸	2,605 ⁸ (11.6) ⁸	1,990 ⁷ (8.9) ⁷	2,550 ⁷ (11.3) ⁷	1,750 ⁹ (7.8) ⁹	4,020 ⁹ (17.9) ⁹	3,030 ⁷ (13.5) ⁷	1,550 ⁸ (6.9) ⁸	2,055 ⁷ (9.1) ⁷
Pullout Strength, concrete on metal deck (uncracked) ³	$N_{p,deck,uncr}$	Lb (kN)	1,580 ⁸ (7.0) ⁸	3,950 ⁸ (17.6) ⁸	2,475 ⁷ (11.0) ⁷	2,660 ⁷ (11.8) ⁷	2,470 ⁷ (11.0) ⁷	5,000 ⁷ (22.2) ⁷	4,275 ⁹ (19.0) ⁹	1,990 ⁸ (8.9) ⁸	2,560 ⁷ (11.4) ⁷
Pullout Strength, concrete on metal deck (seismic) ⁵	$N_{p,deck,eq}$	Lb (kN)	1,230 ⁸ (5.5) ⁸	2,345 ⁸ (10.4) ⁸	1,990 ⁷ (8.9) ⁷	2,550 ⁷ (11.3) ⁷	1,750 ⁹ (7.8) ⁹	4,020 ⁹ (17.9) ⁹	3,030 ⁷ (13.5) ⁷	1,550 ⁸ (6.9) ⁸	2,055 ⁷ (9.1) ⁷
Steel Strength in Shear, concrete on metal deck ⁴	$V_{sa,deck}$	lb (kN)	2,285 (10.2)	3,085 (13.7)	3,430 (15.3)	4,680 (20.8)	3,235 (14.4)	5,430 (24.2)	6,135 (27.3)	3,085 (13.7)	5,955 (26.5)
Steel Strength in Shear, concrete on metal deck (seismic) ⁵	$V_{sa,deck,eq}$	Lb (kN)	2,285 (10.2)	3,085 (13.7)	2,400 (10.7)	3,275 (14.6)	3,235 (14.4)	5,430 (24.2)	5,520 (24.6)	3,085 (13.7)	4,170 (18.5)

For SI: 1 inch = 25.4 mm, 1 lbf = 4.45 N.

¹Installation must comply with Section 4.3 and [Figure 4](#).

²Profile steel deck must comply with [Figure 4](#) and Section 3.3 of this report.

³The values must be used in accordance with Section 4.1.4 of this report.

⁴The values must be used in accordance with Section 4.1.5 of this report.

⁵The values must be used in accordance with Section 4.1.8 of this report.

⁶The minimum anchor spacing along the flute must be the greater of $3h_{ef}$ or 1.5 times the flute width.

⁷The characteristic pull-out strength for greater concrete compressive strengths must be increased by multiplying the tabular value by $(f'_c / 3,000 \text{ psi})^{0.5}$ or $(f'_c / 20.7 \text{ MPa})^{0.5}$.

⁸The characteristic pull-out strength for greater concrete compressive strengths must be increased by multiplying the tabular value by $(f'_c / 3,000 \text{ psi})^{0.3}$ or $(f'_c / 20.7 \text{ MPa})^{0.3}$.

⁹The characteristic pull-out strength for greater concrete compressive strengths must be increased by multiplying the tabular value by $(f'_c / 3,000 \text{ psi})^{0.4}$ or $(f'_c / 20.7 \text{ MPa})^{0.4}$.

¹⁰Concrete shall be normal-weight or sand-lightweight concrete having a minimum specified compressive strength, f'_c , of 3,000 psi (20.7 MPa).

TABLE 5A—CARBON STEEL STRONG-BOLT® 2 ANCHOR INSTALLATION INFORMATION IN THE TOPSIDE OF CONCRETE-FILLED PROFILE STEEL DECK FLOOR AND ROOF ASSEMBLIES^{1,2,3,4}

Design Information	Symbol	Units	Nominal Anchor Diameter (inch)		
			³ / ₈	¹ / ₂	¹ / ₂
Nominal Embedment Depth	h_{nom}	in.	1 ⁷ / ₈	1 ⁷ / ₈	2 ³ / ₄
Effective Embedment Depth	h_{ef}	in.	1 ¹ / ₂	1 ¹ / ₂	2 ¹ / ₄
Minimum Concrete Thickness ⁵	$h_{min,deck}$	in.	2 ¹ / ₂	3 ¹ / ₄	3 ¹ / ₄
Critical Edge Distance	$c_{ac,deck,top}$	in.	4 ³ / ₄	4	4
Minimum Edge Distance	$c_{min,deck,top}$	in.	4 ³ / ₄	4 ¹ / ₂	4 ³ / ₄
Minimum Spacing	$s_{min,deck,top}$	in.	7	6 ¹ / ₂	8

For **SI**: 1 inch = 25.4mm, 1 lbf = 4.45N.

¹Installation must comply with Sections 4.1.6, 4.1.11 and 4.3 and [Figure 5](#) of this report.

²Design capacity shall be based on calculations according to values in [Tables 2A](#) and [3A](#) of this report.

³Minimum flute depth (distance from top of flute to bottom of flute) is 1½ inch, see [Figure 5](#).

⁴Steel deck thickness shall be minimum 20 gauge.

⁵Minimum concrete thickness ($h_{min,deck}$) refers to concrete thickness above upper flute, see [Figure 5](#).

TABLE 5B—STAINLESS STEEL STRONG-BOLT® 2 ANCHOR INSTALLATION INFORMATION IN THE TOPSIDE OF CONCRETE-FILLED PROFILE STEEL DECK FLOOR AND ROOF ASSEMBLIES^{1,2,3,4}

Design Information	Symbol	Units	Nominal Anchor Diameter (inch)		
			³ / ₈	¹ / ₂	¹ / ₂
Nominal Embedment Depth	h_{nom}	in.	1 ⁷ / ₈	1 ⁷ / ₈	2 ³ / ₄
Effective Embedment Depth	h_{ef}	in.	1 ¹ / ₂	1 ¹ / ₂	2 ¹ / ₄
Minimum Concrete Thickness ⁵	$h_{min,deck}$	in.	2 ¹ / ₂	3 ¹ / ₄	3 ¹ / ₄
Critical Edge Distance	$c_{ac,deck,top}$	in.	4 ³ / ₄	4	4
Minimum Edge Distance	$c_{min,deck,top}$	in.	4 ³ / ₄	4 ³ / ₄	6
Minimum Spacing	$s_{min,deck,top}$	in.	6 ¹ / ₂	6 ¹ / ₂	8

For **SI**: 1 inch = 25.4mm, 1 lbf = 4.45N.

¹Installation must comply with Sections 4.1.6, 4.1.11 and 4.3 and [Figure 5](#) of this report.

²Design capacity shall be based on calculations according to values in [Tables 2B](#) and [3B](#) of this report.

³Minimum flute depth (distance from top of flute to bottom of flute) is 1½ inch, see [Figure 5](#).

⁴Steel deck thickness shall be minimum 20 gauge.

⁵Minimum concrete thickness ($h_{min,deck}$) refers to concrete thickness above upper flute, see [Figure 5](#).

TABLE 6—EXAMPLE STRONG-BOLT® 2 ANCHOR ALLOWABLE STRESS DESIGN TENSION VALUES FOR ILLUSTRATIVE PURPOSES^{1,2,3,4,5,6,7,8,9}

Nominal Anchor Diameter (in.)	Nominal Embedment Depth, h_{nom} (in.)	Effective Embedment Depth, h_{ef} (in.)	Allowable Tension Load, $T_{allowable}$ (lbs.)
Carbon Steel			
1/4	3/4	1 1/2	970
3/8	1 7/8	1 1/2	970
	2 7/8	2 1/2	1,465
1/2	2 3/4	2 1/4	1,585
	3 7/8	3 3/8	2,305*
5/8	3 3/8	2 3/4	2,400
	5 1/8	4 1/2	3,965
3/4	4 1/8	3 3/8	3,125
	5 3/4	5	3,895
1	5 1/4	4 1/2	3,110
	9 3/4	9	3,600
Stainless Steel			
1/4	3/4	1 1/2	845
3/8	1 7/8	1 1/2	970
	2 7/8	2 1/2	2,080
1/2	2 3/4	2 1/4	1,420
	3 7/8	3 3/8	1,975
5/8	3 3/8	2 3/4	2,405
	5 1/8	4 1/2	3,345
3/4	4 1/8	3 3/8	3,270
	5 3/4	5	4,225

Design Assumptions:

1. Single Anchor.
2. Tension load only.
3. Concrete determined to remain uncracked for the life of the anchorage.
4. Load combinations taken from ACI 318-14 Section 5.3 or ACI 318-11 Section 9.2, as applicable (no seismic loading).
5. 30 percent Dead Load (D) and 70 percent Live Load (L); Controlling load combination is 1.2D + 1.6L. Calculation of α based on weighted average: $\alpha = 1.2D + 1.6L = 1.2(0.3) + 1.6(0.7) = 1.48$.
6. Normal weight concrete with $f'_c = 2,500$ psi.
7. $C_{a1} = C_{a2} \geq C_{ac}$
8. Concrete thickness, $h \geq h_{min}$
9. Values are for Condition B (supplementary reinforcement in accordance with ACI 318-14 17.3.3 or ACI 318-11 D.4.3 is not provided.)

*Illustrative Procedure (reference [Table 2A](#) of this report for design data):

Strong-Bolt® 2 carbon steel: 1/2-inch diameter anchor with an effective embedment depth, $h_{ef} = 3\ 3/8$ ".

Step 1: Calculate steel strength in tension in accordance with ACI 318-14 17.4.1 or ACI 318-11 D.5.1, as applicable;

$$\phi_{sa}N_{sa} = 0.75 \times 12,100 = 9,075 \text{ lbs.}$$

Step 2: Calculate concrete breakout strength in tension in accordance with ACI 318-14 17.4.1.1 or ACI 318-11 D.5.2, as applicable;

$$\phi_{cb}N_{cb} = 0.65 \times 7,440 = 4,836 \text{ lbs.}$$

Step 3: Calculate pullout strength in tension in accordance with ACI 318-14 17.4.1.1 or ACI 318-11 D.5.3, as applicable;

$$\phi_{p,uncr}N_p = 0.65 \times 5,255 = 3,416 \text{ lbs.}$$

Step 4: The controlling value from Steps 1, 2, and 3 above in accordance with ACI 318-14 17.3.1.2 or ACI 318-11 D.4.1.2, as applicable;

$$\phi N_n = 3,416 \text{ lbs.}$$

Step 5: Divide the controlling value by the conversion factor α as determined in footnote 5 and in accordance with Section 4.2.1 of this report;

$$T_{allowable, ASD} = \phi N_n / \alpha = 3,416 / 1.48 = 2,305 \text{ lbs.}$$

For single anchor and anchor groups, the edge distance, spacing and member thickness requirements in [Tables 1A](#) and [1B](#) of this report apply.

**TABLE 7—LENGTH IDENTIFICATION HEAD MARKS ON STRONG-BOLT® 2 ANCHORS
(CORRESPONDS TO LENGTH OF ANCHOR – INCHES)**

Mark	Units	A	B	C	D	E	F	G	H	I	J	K	L	M
From	in	1½	2	2½	3	3½	4	4½	5	5½	6	6½	7	7½
Up To But Not Including	in	2	2½	3	3½	4	4½	5	5½	6	6½	7	7½	8

Mark	Units	N	O	P	Q	R	S	T	U	V	W	X	Y	Z
From	in	8	8½	9	9½	10	11	12	13	14	15	16	17	18
Up To But Not Including	in	8½	9	9½	10	11	12	13	14	15	16	17	18	19



FIGURE 1—STRONG-BOLT® 2 WEDGE ANCHOR (CARBON STEEL VERSION)

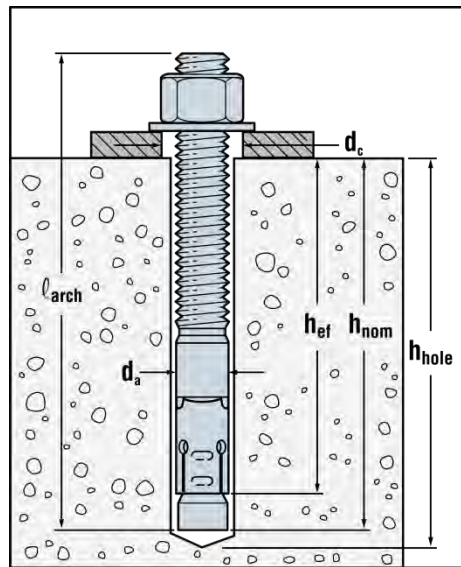

FIGURE 2—STRONG-BOLT® 2 WEDGE ANCHOR INSTALLATION

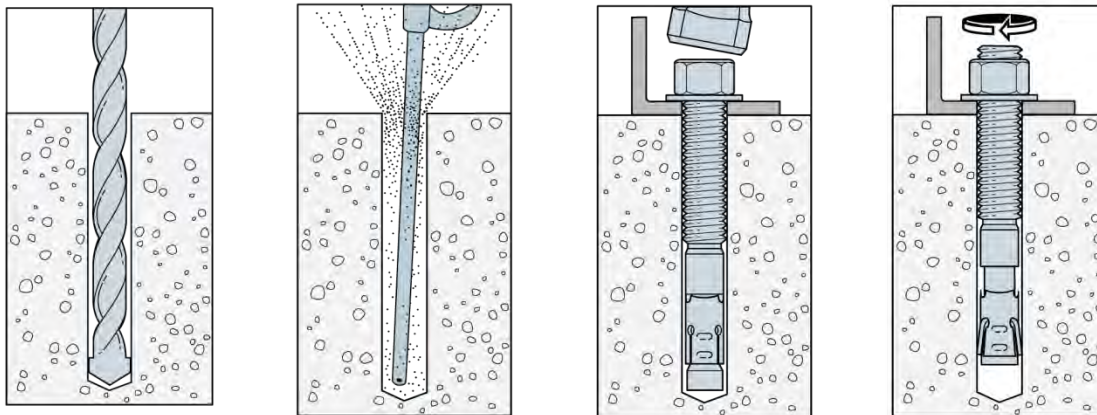

FIGURE 3—STRONG-BOLT® 2 WEDGE ANCHOR INSTALLATION SEQUENCE

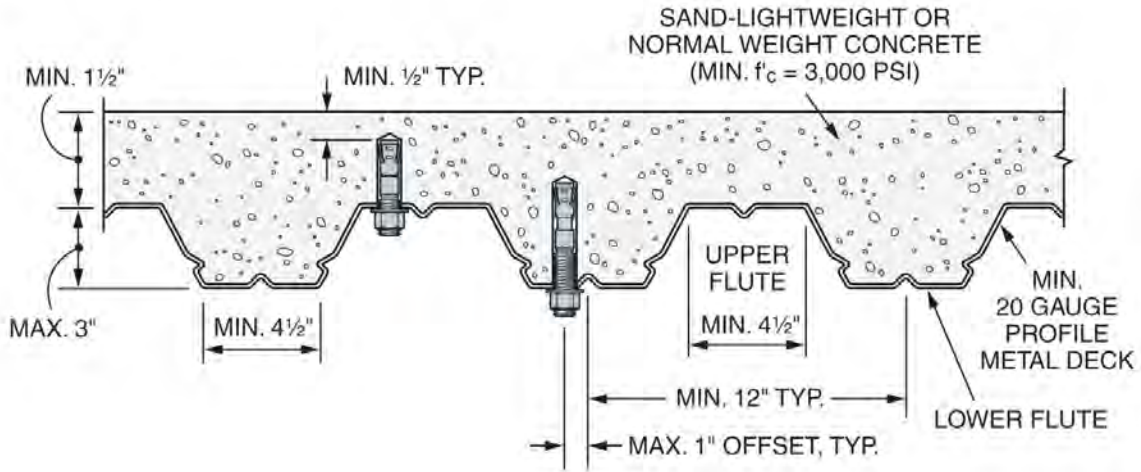

FIGURE 4—INSTALLATION IN THE SOFFIT OF CONCRETE OVER PROFILE STEEL DECK FLOOR AND ROOF ASSEMBLIES¹

¹Anchors may be placed in the upper flute or lower flute of the steel deck assembly provided a minimum 1/2-inch concrete cover beyond the end of the anchor is provided. Anchors in the lower flute of Figure 4 may be installed with a maximum 1-inch offset in either direction from the centerline of the flute.

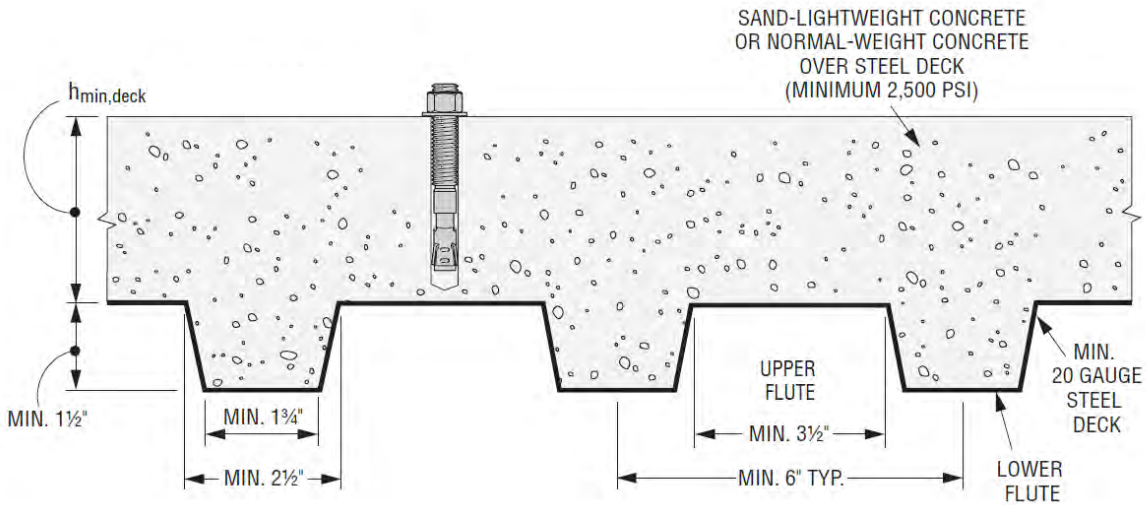

FIGURE 5—INSTALLATION ON THE TOP OF CONCRETE-FILLED PROFILE STEEL DECK FLOOR AND ROOF ASSEMBLIES

(1 in = 25.4 mm)

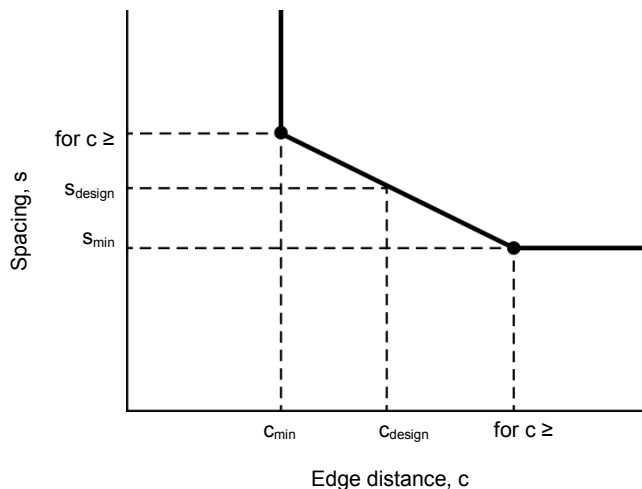
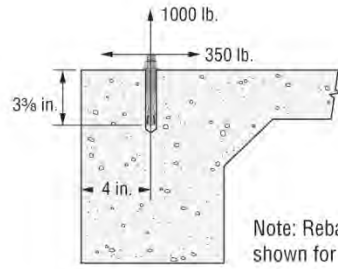

FIGURE 6—INTERPOLATION OF MINIMUM EDGE DISTANCE AND ANCHOR SPACING¹

¹Interpolation only valid for 3/4-inch diameter carbon steel and 3/8-, 1/2- and 5/8-inch-diameter stainless-steel anchors. Spacing and edge distance combinations must fall on or above and to the right of the diagonal line.

Determine if a single ½ inch diameter carbon steel Strong-Bolt® 2 torque-controlled expansion anchor with a minimum 3¾ inch embedment ($h_{ef} = 3\frac{3}{4}$ inches) installed 4 inches from the edge of a 12 inch deep spandrel beam is adequate for a service tension load of 1,000 lb. for wind and a reversible service shear load of 350 lb. for wind. The anchor will be in the tension zone, away from other anchors in $f'_c = 3,000$ psi normal-weight concrete.



	ACI 318-08 Code Ref.	Report Ref.
1. Determine the Factored Tension and Shear Design Loads:	9.2.1	
$N_{ua} = 1.6W = 1.6 \times 1,000 = 1,600$ lb.		
$V_{ua} = 1.6W = 1.6 \times 350 = 560$ lb.		
2. Steel Capacity under Tension Loading:	D.5.1	
$N_{sa} = 12,100$		Table 2A
$\phi = 0.75$		Table 2A
$n = 1$ (single anchor)		
Calculating for ϕN_{sa} :		
$\phi N_{sa} = 0.75 \times 1 \times 12,100 = 9,075$ lb.		
3. Concrete Breakout Capacity under Tension Loading:	D.5.2	
$N_{cb} = \frac{A_{Nc}}{A_{Nco}} \psi_{ed,N} \psi_{c,N} \psi_{cp,N} N_b$	Eq. (D-4);	
where:		
$N_b = k_c \lambda \sqrt{f'_c} h_{ef}^{1.5}$	Eq. (D-7)	
substituting:		
$\phi N_{cb} = \phi \frac{A_{Nc}}{A_{Nco}} \psi_{ed,N} \psi_{c,N} \psi_{cp,N} k_c \lambda \sqrt{f'_c} h_{ef}^{1.5}$		
where:		
$k_c = k_{cr} = 17$		Table 2A
$\lambda = 1.0$ for normal-weight concrete	8.6.1	
$\psi_{cp,N} = 1.0$	D.5.2.7	
$\psi_{ed,N} = 0.7 + 0.3 \frac{c_{a,min}}{1.5h_{ef}}$ when $c_{a,min} < 1.5 h_{ef}$	Eq. (D-11)	
by observation, $c_{a,min} = 4 < 1.5h_{ef}$		
$\psi_{ed,N} = 0.7 + 0.3 \frac{(4)}{1.5(3.375)} = 0.94$		
$\psi_{c,N} = 1.0$ assuming cracking at service loads ($f_t > f_r$)	D.5.2.6	
$\phi = 0.65$ for Condition B (no supplementary reinforcement provided)		Table 2A
$A_{Nco} = 9h_{ef}^2 = 9(3.375)^2 = 102.52$ in. ²	Eq. (D-6)	
$A_{Nc} = (c_{a1} + 1.5h_{ef})(2 \times 1.5h_{ef}) = (4 + 1.5(3.375))(2 \times 1.5(3.375)) = 91.76$ in. ²	Fig. RD.5.2.1(a)	
$\frac{A_{Nc}}{A_{Nco}} = \frac{91.76}{102.52} = 0.90$		
Calculating for ϕN_{cb} :		
$\phi N_{cb} = 0.65 \times 0.90 \times 0.94 \times 1.0 \times 1.0 \times 17 \times 1.0 \times \sqrt{3,000} \times (3.375)^{1.5} = 3,175$ lb.		

	ACI 318-08 Code Ref.	Report Ref.
4. Pullout Capacity:	D.5.3	
$N_{pn,cr} = 3,735 \times \left(\frac{3,000}{2,500}\right)^{0.5} = 4,091$ lb.		Table 2A
$\phi = 0.65$		Table 2A
$\phi N_{pn} = 0.65 \times 4,091 = 2,659$		
5. Check All Failure Modes under Tension Loading:	D.4.1.2	
Summary:		
Steel Capacity = 9,075 lb.		
Concrete Breakout Capacity = 3,175 lb.		
Pullout Capacity = 2,659 lb. ← Controls		
∴ $\phi N_n = 2,659$ lb. as Pullout Capacity controls $> N_{ua} = 1,600$ lb. – OK		
6. Steel Capacity under Shear Loading:	D.6.1	
$V_{sa} = 7,235$ lb.		Table 3A
$\phi = 0.65$		Table 3A
Calculating for ϕV_{sa} :		
$\phi V_{sa} = 0.65 \times 7,235 = 4,703$ lb.		
7. Concrete breakout Capacity under Shear Loading:	D.6.2	
$V_{cb} = \frac{A_{Vc}}{A_{Vco}} \psi_{ed,V} \psi_{c,V} \psi_{h,V} V_b$	Eq. (D-21)	
where:		
$V_b = 7 \left(\frac{\ell_e}{d_a}\right)^{0.2} \sqrt{d_a} \lambda \sqrt{f'_c} c_{a1}^{1.5}$	Eq. (D-24)	
substituting:		
$\phi V_{cb} = \phi \frac{A_{Vc}}{A_{Vco}} \psi_{ed,V} \psi_{c,V} \psi_{h,V} 7 \left(\frac{\ell_e}{d_a}\right)^{0.2} \sqrt{d_a} \lambda \sqrt{f'_c} c_{a1}^{1.5}$		
where:		
$\phi = 0.70$ for Condition B (no supplementary reinforcement provided)		Table 3A
$A_{Vco} = 4.5c_{a1}^2 = 4.5(4)^2 = 72$ in. ²	Eq. (D-23)	
$A_{Vc} = 2(1.5c_{a1})(1.5c_{a1}) = 2(1.5(4))(1.5(4)) = 72$ in. ²	Fig. RD.6.2.1(a)	
$\frac{A_{Vc}}{A_{Vco}} = \frac{72}{72} = 1$	D.6.2.1	
$\psi_{ed,V} = 1.0$ since $c_{a2} > 1.5c_{a1}$	Eq. (D-27)	
$\psi_{c,V} = 1.0$ assuming cracking at service loads ($f_t > f_r$)	D.6.2.7	
$h_a = 12$ in.		
$\psi_{h,V} = 1.0$ since $h_a > 1.5c_{a1}$	D.6.2.8	
$d_a = 0.5$ in.		
$\ell_e = 3.375$ in.	D.6.2.2	
$\lambda = 1.0$ for normal-weight concrete	8.6.1	
$c_{a1} = 4$ in.		
$\phi V_{cb} = 0.70 \times 1 \times 1.0 \times 1.0 \times 1.0 \times 7 \times \left(\frac{3.375}{0.5}\right)^{0.2} \times \sqrt{0.5} \times 1.0 \times \sqrt{3,000} \times (4)^{1.5} = 2,224$ lb.		

FIGURE 7—STRONG-BOLT® 2 ANCHOR EXAMPLE CALCULATION

	ACI 318-08 Code Ref.	Report Ref.
8. Concrete Pryout Strength:	D.6.3	
$V_{cp} = k_{cp} N_{cb}$	Eq. (D-30)	
where:		
$n = 1$		
$\phi = 0.70$		Table 3A
$k_{cp} = 2.0$	D.6.3.1	
$k_{cp} N_{cb} = 2.0 \times \frac{3,175}{0.65} = 9,769 \text{ lb.}$	D.6.3.1	
$\phi n V_{cp} = 0.70 \times 1 \times 9,769 = 6,838 \text{ lb.}$		
9. Check All Failure Modes under Shear Loading:	D.4.1.2	
Summary:		
Steel Capacity = 4,703 lb.		
Concrete Breakout Capacity = 2,224 lb. ← Controls		
Pryout Capacity = 6,838 lb.		
∴ $\phi V_n = 2,224 \text{ lb.}$ as Concrete Breakout Capacity controls >		
$V_{ua} = 560 \text{ lb.} - \text{OK}$		

	ACI 318-08 Code Ref.	Report Ref.
10. Check Interaction of Tension and Shear Forces:	D.7	
If $0.2 \phi V_n \geq V_{ua}$, then the full tension design strength is permitted.	D.7.1	
By observation, this is not the case.		
If $0.2 \phi N_n \geq N_{ua}$, then the full shear design strength is permitted	D.7.2	
By observation, this is not the case.		
Therefore:		
$\frac{N_{ua}}{\phi N_n} + \frac{V_{ua}}{\phi V_n} \leq 1.2$	Eq. (D-32)	
$\frac{1,600}{2,659} + \frac{560}{2,224} = 0.60 + 0.25 = 0.85 < 1.2 - \text{OK}$		
11. Summary		
A single 1/2 in. diameter carbon steel Strong-Bolt® 2 anchor at a 3/4 in. embedment depth is adequate to resist the applied service tension and shear loads of 1,000 lb. and 350 lb., respectively.		

FIGURE 7—STRONG-BOLT® 2 ANCHOR EXAMPLE CALCULATION (Continued)