



## OPTIONAL FLAT PANEL TV MOUNTING SYSTEM

*T*his heavy duty Flat Panel TV Mounting System is designed to hang most Flat Panel Plasma or LCD TVs up to 63" (not exceeding 175 lbs.) above select Wood Audio/Video Cabinets. Made of heavy duty, scratch resistant powder-coated steel, it includes universal mounting brackets and most common hardware needed for TV mounting. A CMS® Cable Management System is included to hide wires and interconnect cables. Designed for use with select Bell'O® and PRO Bell'O® Wood Audio/Video Cabinets.

DETAILED DIMENSIONS

Overall:  
34" w x 59" h x 10<sup>3</sup>/<sub>8</sub>" d

Universal Mount  
(27" w and 34" w  
Mounting Bracket  
Sets Included)

Designed for use with  
select Bell'O® and  
PRO Bell'O® Wood  
Audio/Video Cabinets.

Weight Capacity:  
175 lbs. (79.4 kg)

All measurements shown are nominal usable space.  
Specifications are subject to change without notice.

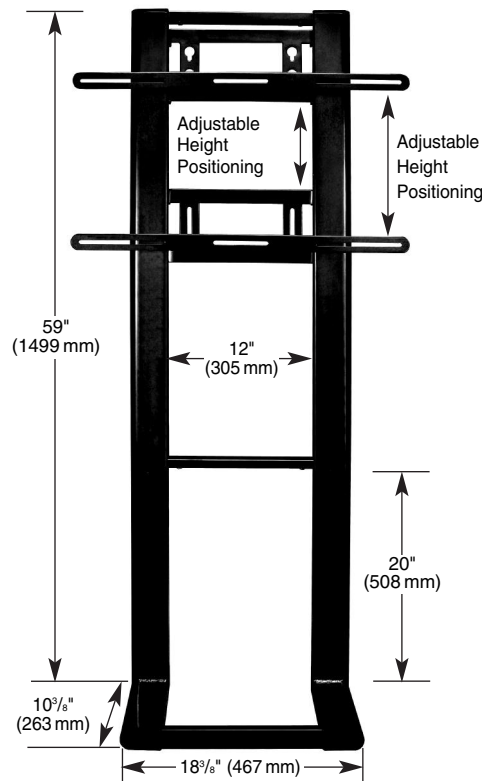

DESIGN FEATURES



WAVS-325  
shown with PP-59B

- Designed to hang most Flat Panel Plasma or LCD TVs up to 63" above select Bell'O® Wood Audio/Video Cabinets
- Heavy duty frame crafted of powder-coated, scratch resistant steel in Black finish
- Includes universal mounting brackets and most common hardware needed for mounting TV
- CMS® Cable Management System hides wires and interconnect cables

©2012 Bell'O International Corporation. All designs are patented or patent pending. Pricing, availability and specifications are subject to change without notice.