

| PAT-5000-001 | IMPERIAL | METRIC |
|---------------------------------------|-----------|---------|
| CASING O.D. (in) (mm) | 5.00 | 127.00 |
| CASING WT. (lb/ft) (kg/m) | 18 | 26.79 |
| CASING I.D. (in) (mm) | 4.276 | 108.610 |
| PATCH MAX. RUNNING O.D. (in) (mm) | 4.080 | 103.632 |
| PATCH I.D. AFTER SETTING (in) (mm) | 3.500 | 88.900 |
| BURST HYDRAULIC RATING (psi) (Mpa) | 5,650 | 38.96 |
| COLLAPSE HYDRAULIC RATING (psi) (Mpa) | 6,000 | 41.37 |
| GAS BURST RATING (psi) (Mpa) | N/A | |
| GAS COLLAPSE RATING (psi) (Mpa) | | |
| SYSTEM MATERIAL | 1018-1026 | |

| ITEM | QTY | DESCRIPTION | PAT-5000-001 |
|------------------------------|-------|----------------------|----------------------------------|
| SHORT ASSY.-ITEMS 1-7 | | | |
| 1 | 1 | PIN ELEMENT | PAT-5000-020 |
| 2 | 1 | BOX ELEMENT | PAT-5000-021 |
| 3 | 1 | TOP SWAGE | PAT-5000-024 |
| 4 | 1 | BOTTOM SWAGE | PAT-5000-025 |
| 5 | "N"+1 | PIN O-RING | OOO-N569-153 |
| 6 | "N"+1 | BOX O-RING | OOO-N569-154 |
| 7 | 1 | RELEASE RING | PAT-4500-038 (72K) |
| 8 | "N" | 10-FT. SECTION | PAT-5000-037 |
| | OPT. | 5-FT. SECTION | PAT-5000-038 |
| 9 | 1 | SETTING TOOL | SET-3250-010 3-1/4" O.D. MSST |
| 10 | 1 | SLEEVE NUT | SET-3250-120 |
| 11 | 1 | SLEEVE LOCK NUT | SET-3250-121 |
| 12 | 1 | SETTING SLEEVE ASSY. | SET-3250-126 |
| | 1 | SETTING SLEEVE | SET-3250-124 |
| | 1 | BOTTOM GUIDE | SET-3250-129 |
| 13 | 1 | QUICK CHANGE ROD | SET-3250-130 |
| 14 | 1 | QUICK CHANGE NUT | SET-3250-131 |
| 15 | 1 | TOP ROD LOCK NUT | SET-3500-025 |
| 16 | 1 | TOP ADAPTER ROD | SET-3250-132 |
| 17 | "N"+2 | ROD TANDEM CONNECTOR | SET-3250-133 |
| 18 | "N" | 10-FT. ROD | SET-3250-134 |
| | OPT. | 5-FT. ROD | SET-3250-135 |
| 19 | 1 | BOTTOM ROD | SET-3250-136 |
| 20 | 1 | COLLET ASSY. | SET-3250-144 |
| | 1 | END SUB | SET-3250-139 |
| | 1 | COLLET BODY | SET-3250-145 |
| 21 | 1 | COLLET SUPPORT | SET-3250-140 |
| 22 | "N" | ROD SUPPORT | SET-3250-142 |

Note: "N" = Patch Length (in feet) divided by 10
 Note: "N" = Patch Length (in meters) divided by 3.048

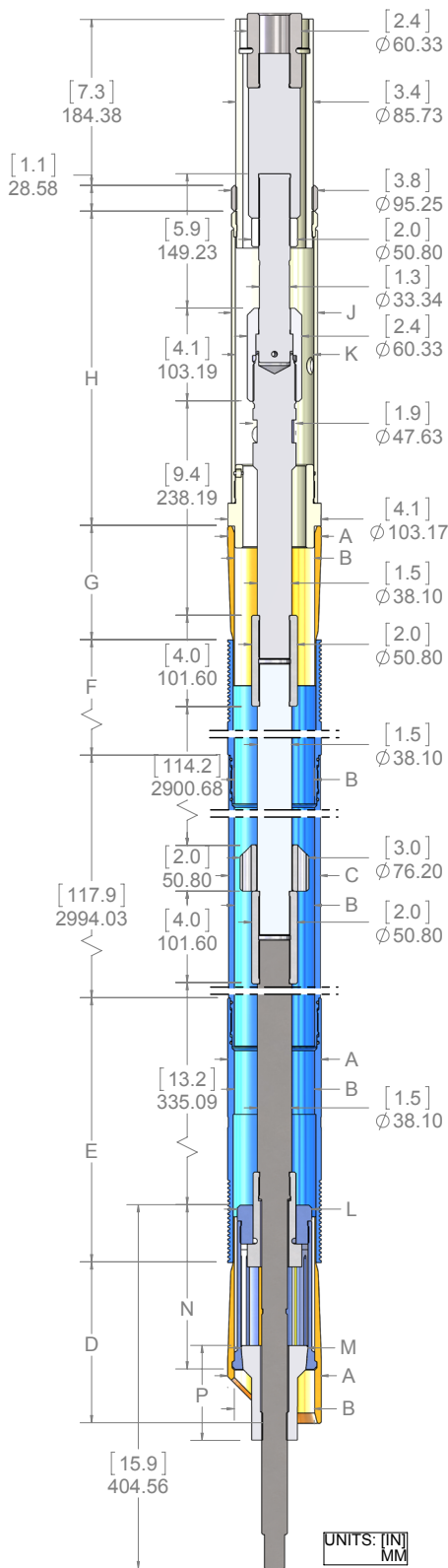

| PAT-5000-001 | IMPERIAL | METRIC | |
|---------------------------------------|-----------|------------|--------|
| CASING O.D. (in) (mm) | 5.00 | 127.00 | |
| CASING WT. (lb/ft) (kg/m) | 18 | 22.47 | |
| CASING I.D. (in) (mm) | 4.276 | 108.61 | |
| PATCH MAX. RUNNING O.D. (in) (mm) | 4.080 | 103.63 | |
| PATCH I.D. AFTER SETTING (in) (mm) | 3.500 | 88.90 | |
| BURST HYDRAULIC RATING (psi) (Mpa) | 5,650 | 38.96 | |
| COLLAPSE HYDRAULIC RATING (psi) (Mpa) | 6,000 | 41.37 | |
| GAS BURST RATING (psi) (MPa) | N/A | | |
| GAS COLLAPSE RATING (psi) (Mpa) | | | |
| SYSTEM MATERIAL | 1018-1026 | | |
| | | DIMENSIONS | |
| REF. BOM | ITEM | INCHES | MM |
| A | 1,2,3,4 | 4.080 | 103.63 |
| B | 1,2,3,4,8 | 3.500 | 88.90 |
| C | 8 | 4.000 | 101.60 |
| D | 4 | 7.040 | 178.82 |
| E | 2 | 11.560 | 293.62 |
| F | 1 | 9.430 | 239.52 |
| G | 3 | 5.000 | 127.00 |
| H | 12 | 13.750 | 349.24 |
| J | 12 | 3.750 | 95.25 |
| K | 12 | 3.425 | 87.00 |
| L | 20 | 3.250 | 82.55 |
| M | 21 | 2.906 | 73.81 |
| N | 20 | 7.187 | 182.56 |
| P | 21 | 4.156 | 105.57 |

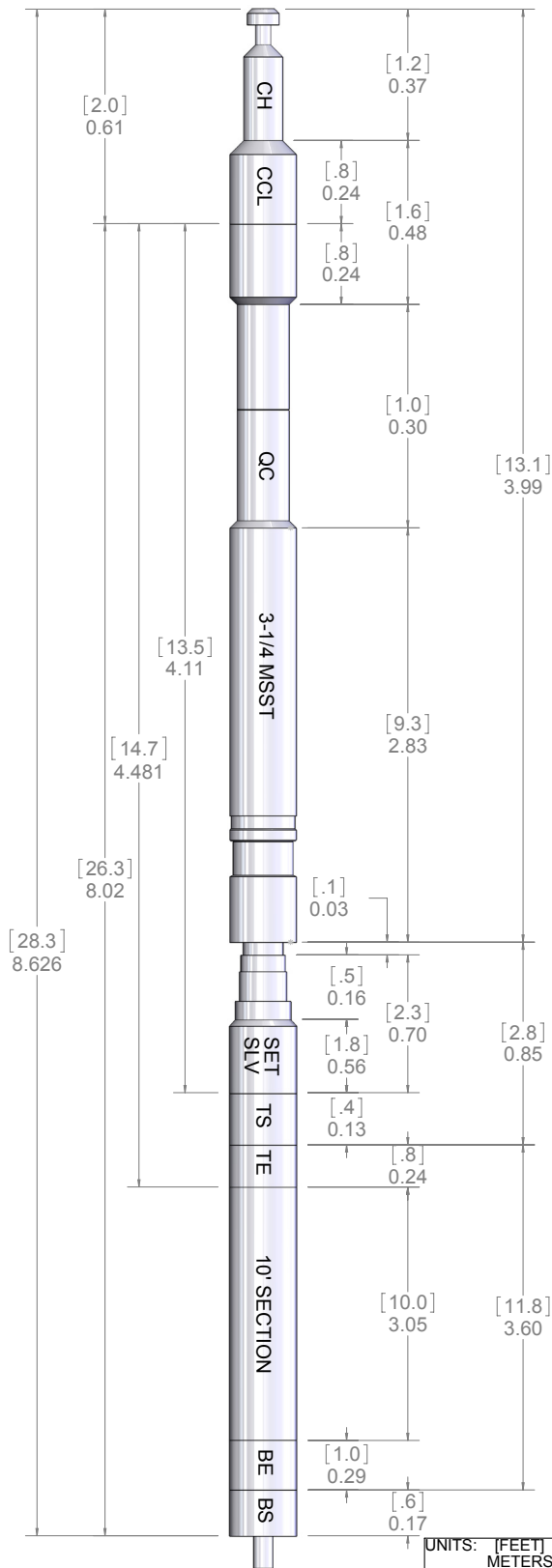

| PAT-5000-001 | | |
|--------------|--------------|--------------|
| DESCRIPTION | WEIGHT (LBS) | WEIGHT (KG) |
| CABLEHEAD | 4.0 | 1.8 |
| 3-1/4 CCL | 36.0 | 16.3 |
| 3-1/4 Q.C. | 14.0 | 6.4 |
| 3-1/4 MSST | 206.0 | 93.4 |
| TOTAL | 260.0 | 117.9 |

| | | |
|------------------|--------------|--------------|
| PAT. SHORT ASSY. | 25.7 | 11.6 |
| *10-FT SECTION | 98.4 | 44.6 |
| *10-FT ROD | 59.8 | 27.1 |
| *TAND. COUPL. | 2.0 | 0.9 |
| *ROD SUPPORT | 2.3 | 1.0 |
| Q.C. ROD | 3.5 | 1.6 |
| Q.C. NUT | 2.5 | 1.1 |
| TOP ROD | 7.5 | 3.4 |
| BOTTOM ROD | 11.3 | 5.1 |
| SLEEVE NUT | 7.7 | 3.5 |
| SLEEVE LOCK NUT | 0.7 | 0.3 |
| SETTING SLEEVE | 11.0 | 5.0 |
| COLLET ASSEMBLY | 4.8 | 2.2 |
| COLLET SUPPORT | 3.4 | 1.6 |
| TOTAL | 240.5 | 109.1 |

| | | |
|---------------------|--------------|--------------|
| TOTAL WEIGHT | 500.5 | 227.0 |
|---------------------|--------------|--------------|

*EA. ADDITIONAL 10-FT. LGTH ADD 162.427 LBS

*EA. ADDITIONAL 3.05-METER LGTH ADD 73.70 KG