



Visidec focus | dual screen notebook and monitor combo **VF-AT-NBC**
 Fits most displays from 12" to 24" and notebooks up to 18.4"



Mounting hole pattern:
 from 75mm to 75mm wide
 from 100mm to 100mm high



Maximum weight carrying capacity:
 8kg (17.5lbs) per arm

The Visidec Focus VF-AT-NBC allows for a dual display configuration that features a single monitor and notebook next to each other in the most ergonomic way for enhanced dual screen productivity. This elegant polished aluminum mounting system has two independent arms that can each be set to the optimum height and distance from the user to ensure a healthy posture and reduce the potential for occupational injury for notebook users, with the added benefit of a dual screen configuration. It also allows you to align your notebook screen level with your monitor. The overall effect of the system is a more ergonomic and dynamic workspace, leaving the user free to achieve their productive and creative potential. The accessory arm can be tilted by 70° up and 70° down and panned through 180°, and positioned in and out for the ideal focal length.



Product key features:

Notebook tray:

- ✕ Non-slip ventilated notebook tray supports notebooks up to 18.4"
- ✕ Offers a wide range of movement via three pivot points
- ✕ Internal cable management
- ✕ 360° rotation around pole
- ✕ Tray adjustable tilt: from 15° to 35° of forward tilt
- ✕ Adjustable pan: 90° left and right, total 180°
- ✕ Bolt through and desk clamp mounting options included
- ✕ Internal cable management
- ✕ Comes with all mounting hardware
- ✕ Designed to be used in conjunction with a separate keyboard and mouse

Monitor arm:

- ✕ Offers a wide range of movement via 3 pivot points
- ✕ 360° rotation around pole
- ✕ Adjustable tilt: 70° up and 70° down
- ✕ Adjustable pan: 90° left and right, total 180°
- ✕ Portrait to landscape rotation
- ✕ Arm maximum reach: 413mm (16.25")

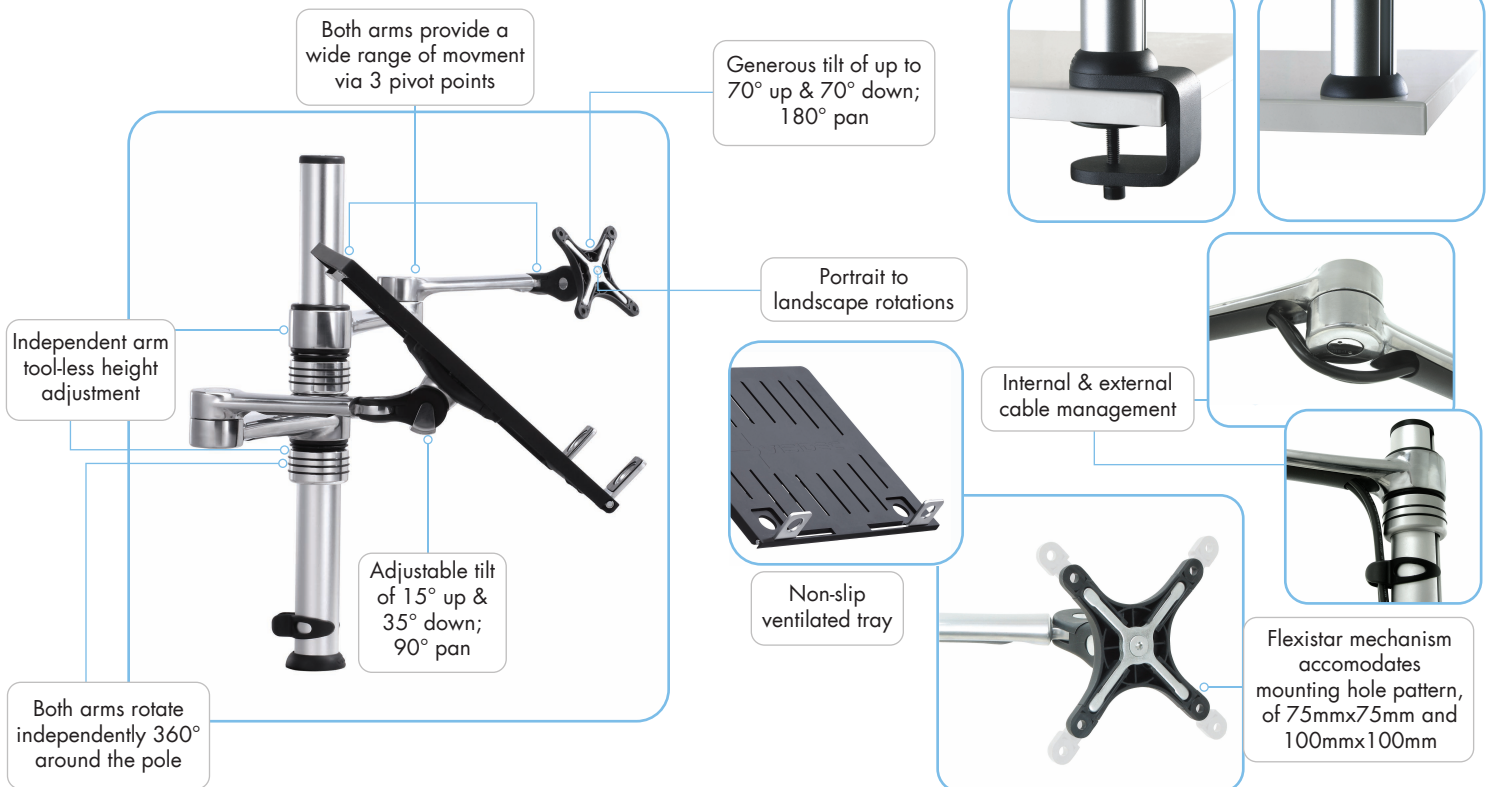

Atdec North America www.atdec.com
 Atdec Global www.atdec.com.au

Product information, single unit

Load capacity	Material	Color
8kg (17.5lbs) per arm	Aluminum/Polymer	Polished

Package information, single unit

Size	Ship weight	UPC code	Contents
(13.8" x 12.4" x 5.3")	(3.5lbs)	881493006287	All hardware required for installation supplied

Package information, master pack

Size	Ship weight	UPC	Units per master pack
(30" x 13.5" x 16.75")	(23lbs)	881493005037	6

Technical drawings

