



**OPEN** Industry Standard, Flexible Architecture

**GREEN** Less Heat, Less Power Consumption

**STABLE** Robust Design, Quality Parts

Stable and  
Reliable Solution

# Server/Workstation

Motherboard

EP2C606-4L/D16

EP2C602-4L/D16

EP2C602/D16

EP2C606-4L

EP2C602-4L

EP2C602



# User Manual



---

## Copyright Notice:

No part of this manual may be reproduced, transcribed, transmitted, or translated in any language, in any form or by any means, except duplication of documentation by the purchaser for backup purpose, without written consent of ASRock Rack Inc.

Products and corporate names appearing in this manual may or may not be registered trademarks or copyrights of their respective companies, and are used only for identification or explanation and to the owners' benefit, without intent to infringe.

## Disclaimer:

Specifications and information contained in this manual are furnished for informational use only and subject to change without notice, and should not be constructed as a commitment by ASRock Rack. ASRock Rack assumes no responsibility for any errors or omissions that may appear in this manual.

With respect to the contents of this manual, ASRock Rack does not provide warranty of any kind, either expressed or implied, including but not limited to the implied warranties or conditions of merchantability or fitness for a particular purpose.

In no event shall ASRock Rack, its directors, officers, employees, or agents be liable for any indirect, special, incidental, or consequential damages (including damages for loss of profits, loss of business, loss of data, interruption of business and the like), even if ASRock Rack has been advised of the possibility of such damages arising from any defect or error in the manual or product.



This device complies with Part 15 of the FCC Rules. Operation is subject to the following two conditions:

- (1) this device may not cause harmful interference, and
- (2) this device must accept any interference received, including interference that may cause undesired operation.

## CALIFORNIA, USA ONLY

The Lithium battery adopted on this motherboard contains Perchlorate, a toxic substance controlled in Perchlorate Best Management Practices (BMP) regulations passed by the California Legislature. When you discard the Lithium battery in California, USA, please follow the related regulations in advance.

"Perchlorate Material-special handling may apply, see [www.dtsc.ca.gov/hazardouswaste/perchlorate](http://www.dtsc.ca.gov/hazardouswaste/perchlorate)"

**ASRock Rack Website: <http://www.asrockrack.com>**

---

# Contents

<b>1 Introduction .....</b>	<b>5</b>
1.1 Package Contents.....	5
1.2 Specifications.....	6
1.3 Motherboard Layout.....	12
1.4 I/O Panel.....	33
1.5 Block Diagram.....	39
<b>2 Installation .....</b>	<b>45</b>
2.1 Pre-installation Precautions .....	45
2.2 Screw Holes.....	45
2.3 CPU Installation .....	46
2.4 Installation of Heatsink and CPU fan .....	48
2.5 Installation of Memory Modules (DIMM) .....	49
2.6 Expansion Slots (PCI and PCI Express Slots)....	51
2.7 Jumpers Setup.....	53
2.8 Onboard Headers and Connectors .....	54
2.9 Driver Installation Guide.....	64
2.10 Hot Plug for Hard Disk Drives .....	65

---

<b>3</b>	<b>UEFI SETUP UTILITY</b>	<b>66</b>
3.1	Introduction	66
3.1.1	UEFI Menu Bar	66
3.1.2	Navigation Keys	67
3.2	Main Screen	68
3.3	Advanced Screen	69
3.3.1	ACPI Configuration	70
3.3.2	WHEA Configuration	72
3.3.3	CPU Configuration	73
3.3.4	North Bridge Configuration	75
3.3.5	South Bridge Configuration	79
3.3.6	USB Configuration	80
3.3.7	Intel ME Subsystem	81
3.3.8	Clock Generator Configuration	82
3.3.9	Storage Configuration	83
3.3.10	Super IO Configuration	85
3.3.11	Serial Port Console Redirection	86
3.3.12	Voltage Control	87
3.4	Hardware Health Event Monitoring Screen	88
3.5	Server Management	90
3.6	Boot Screen	91
3.7	Security Screen	93
3.8	Exit Screen	94
3.9	Event Logs	95
<b>4</b>	<b>Software Support</b>	<b>96</b>
4.1	Install Operating System	96
4.2	Support CD Information	96
4.2.1	Running Support CD	96
4.2.2	Drivers Menu	96
4.2.3	Utilities Menu	96
4.2.4	Contact Information	96
<b>5</b>	<b>Troubleshooting</b>	<b>97</b>
5.1	Troubleshooting Procedures	97
5.2	Technical Support Procedures	97
5.3	Returning Merchandise for Service	97

---

## Chapter 1: Introduction

Thank you for purchasing ASRock Rack **EP2C606-4L/D16 / EP2C602-4L/D16 / EP2C602/D16 / EP2C606-4L / EP2C602-4L / EP2C602** motherboard, a reliable motherboard produced under ASRock Rack's consistently stringent quality control. It delivers excellent performance with robust design conforming to ASRock Rack's commitment to quality and endurance. In this manual, chapter 1 and 2 contains the introduction of the motherboard and step-by-step hardware installation guide. Chapter 3 and 4 contains the configuration guide of BIOS setup and information of the Support CD.



Because the motherboard specifications and the BIOS software might be updated, the content of this manual will be subject to change without notice. In case any modifications of this manual occur, the updated version will be available on ASRock Rack's website without further notice. You may find the latest memory and CPU support list on ASRock Rack's website as well. ASRock Rack website <http://www.asrockrack.com>

If you require technical support related to this motherboard, please visit our website for specific information about the model you are using.

<http://www.asrockrack.com/support/index.asp>

### 1.1 Package Contents

ASRock Rack **EP2C606-4L/D16 / EP2C602-4L/D16 / EP2C602/D16 / EP2C606-4L / EP2C602-4L / EP2C602** Motherboard

(SSI EEB Form Factor: 12.0-in x 13-in, 30.5 cm x 33 cm)

User Manual

Support CD

8 x Serial ATA (SATA) Data Cables (Optional)

1 x I/O Panel Shield

## 1.2 Specifications

### EP2C606-4L/D16 / EP2C602-4L/D16 / EP2C602/D16:

<b>Physical Status</b>	Form Factor	SSI EEB	
	Dimension	12" x 13" (30.5 cm x 33 cm)	
<b>Processor System</b>	CPU	- Supports Intel® Xeon processor E5-1600*/2600/4600 & v2 series * E5-1400 & E5-1600 support single socket.	
	Socket	Dual Socket R (LGA2011)	
	Power Phase	6 +1 Power Phase Design	
	Chipset	<b>EP2C606-4L/D16</b>	
		Intel® C606	
<b>EP2C602-4L/D16 / EP2C602/D16</b>			
Intel® C602			
<b>BIOS</b>	BIOS type	64Mb AMI UEFI Legal BIOS	
<b>System Memory</b>	Max. Capacity	256GB DDR3 RDIMM	
	Socket	16 x 240-pin DDR3 DIMM slots	
	Type	Quad Channel DDR3 1600/1333/1066 LR / Registered /ECC/ UDIMM	
	Voltage	- 1.5V, 1.35V	
<b>Expansion Slot</b>	PCIe 3.0 x 16	4 slots (2 x16, 1 x16/x8, 1 x8/x0)	
	PCIe 3.0 x 4	1 slots	
	PCI	1 slots	
<b>Storage</b>	SATA/SAS controller	<b>EP2C606-4L/D16</b>	
		2 x SATA3 6.0 Gb/s , 4 x SATA2 3.0 Gb/s , 8xSATA2/SAS 3Gb/s	
		<b>EP2C602-4L/D16 / EP2C602/D16</b>	
	2 x SATA3 6.0 Gb/s , 8 x SATA2 3.0 Gb/s		
Additional SATA controller	Marvell 9230 : 4 x SATA3 6.0 Gb/s		
<b>BMC</b>	Controller	ASPEED AST2300	

<b>Graphics</b>	Controller	ASPEED AST2300
	VRAM	DDR3 16MB
	Output	Supports D-Sub with max. resolution up to 1920x1200 @ 60Hz
<b>Ethernet</b>	Interface	Gigabit LAN 10/100/1000 Mb/s
	IPMI dedicated GLAN	Realtek RTL8211E
	LAN Controller	<b>EP2C606-4L/D16 / EP2C602-4L/D16</b>
		4 x Intel® 82574L
		<b>EP2C602/D16</b>
	2 x Intel® 82574L	
<b>Rear Panel I/O</b>	Lan port (RJ45)	<b>EP2C606-4L/D16 / EP2C602-4L/D16</b>
		4 + 1 (for IPMI)
		<b>EP2C602/D16</b>
		2 + 1 (for IPMI)
	PS/2 KB/mouse	2
	VGA port	D-sub x 1
	USB port	2 x USB 2.0
Serial port	1 (COM1)	
<b>Internal connector</b>	COM port header	1 (COM2)
	Auxiliary panel header	1 (include chassis intrusion , location button & LED, front LAN LED)
	TPM header	1
	IPMB header	1
	Buzzer	1
	Fan header	"8 x 4-pin" or "6 x 4-pin and 2 x 3-pin" *CPU fan header have 3-pin and 4-pin, only one of them can be used at a time.
	ATX power	1 (24-pin) + 2(8-pin)
	USB header	2 (each support 2 USB 2.0)
	Type A USB 2.0 port	1

<b>Internal connector</b>	80 debug port LED	1
	Front panel	1
	Speaker(4pin)	1
<b>Support OS</b>	OS	<b>EP2C606-4L/D16</b>
		<b>Microsoft® Windows® :</b> Windows 2003 32/64 (IDE mode) Windows 2003 R2 32/64 (IDE/AHCI mode) Windows 2008 32/64 Windows 2008 R2  <b>Linux:</b> RedHad Enterprise Linux Server 5.5 32/64 ( AHCI mode) RedHad Enterprise Linux Server 6.0 32/64 ( AHCI mode) RedHad Enterprise Linux Server 6.4 32/64 CentOS 5.5 32/64 (AHCI mode) CentOS 6.0 32/64 (AHCI mode) Suse 10.3 32/64 (AHCI mode) Suse 11.1 32/64 (AHCI mode) VMware ESXi 5.1
		<b>EP2C602-4L/D16 / EP2C602/D16</b>
		<b>Microsoft® Windows® :</b> Windows 2003 32/64 (IDE mode) Windows 2003 R2 32/64 (IDE/AHCI mode) Windows 2008 32/64 Windows 2008 R2 Windows 2012 Windows 2012 R2  <b>Linux:</b> RedHad Enterprise Linux Server 5.5 32/64 ( AHCI mode) RedHad Enterprise Linux Server 6.0 32/64 ( AHCI mode) RedHad Enterprise Linux Server 6.4 32/64 CentOS 5.5 32/64 (AHCI mode) CentOS 6.0 32/64 (AHCI mode) Suse 10.3 32/64 (AHCI mode) Suse 11.1 32/64 (AHCI mode) VMware ESXi 5.1

\* For detailed product information, please visit our website: <http://www.asrockrack.com>

\* EP2C606-4L/D16 is build-to-order manufacturing.



**EP2C606-4L / EP2C602-4L / EP2C602:**

<b>Physical Status</b>	Form Factor	EEB	
	Dimension	12" x 13" (30.5 cm x 33 cm)	
<b>Processor System</b>	CPU	- Supports Intel® Xeon processor E5-1600*/2600/4600 & v2 series * E5-1400 & E5-1600 support single socket.	
	Socket	Dual Socket R (LGA2011)	
	Power Phase	6 +1 Power Phase Design	
	Chipset	<b>EP2C606-4L</b>	
		Intel® C606	
<b>EP2C602-4L / EP2C602</b>			
Chipset		Intel® C602	
<b>BIOS</b>	BIOS type	64Mb AMI UEFI Legal BIOS	
<b>System Memory</b>	Max. Capacity	128GB DDR3 RDIMM	
	Socket	8 x 240-pin DDR3 DIMM slots	
	Type	Quad Channel DDR3 1600/1333/1066 LR / Registered /ECC/ UDIMM	
	Voltage	- 1.5V, 1.35V	
<b>Expansion Slot</b>	PCIe 3.0 x 16	5 slots (3 x16, 1 x16/x8, 1 x8/x0)	
	PCIe 3.0 x 4	1 slots	
	PCI	1 slots	
<b>Storage</b>	SATA/SAS controller	<b>EP2C606-4L</b>	
		2 x SATA3 6.0 Gb/s , 4 x SATA2 3.0 Gb/s , 8x SATA2/SAS 3Gb/s	
		<b>EP2C602-4L / EP2C602</b>	
	2 x SATA3 6.0 Gb/s , 8 x SATA2 3.0 Gb/s		
Additional SATA controller		Marvell 9230 : 4 x SATA3 6.0 Gb/s	
<b>BMC</b>	Controller	ASPEED AST2300	

<b>Graphics</b>	Controller	ASPEED AST2300	
	VRAM	DDR3 16MB	
	Output	Supports D-Sub with max. resolution up to 1920x1200 @ 60Hz	
<b>Ethernet</b>	Interface	Gigabit LAN 10/100/1000 Mb/s	
	IPMI dedicated GLAN	Realtek RTL8211E	
	LAN Controller	<b>EP2C606-4L / EP2C602-4L</b>	
		4 x Intel® 82574L	
		<b>EP2C602</b>	
		2 x Intel® 82574L	
<b>Rear Panel I/O</b>	Lan port (RJ45)	<b>EP2C606-4L / EP2C602-4L</b>	
		4 + 1 (for IPMI)	
		<b>EP2C602</b>	
		2 + 1 (for IPMI)	
	PS/2 KB/mouse	2	
	VGA port	D-sub x 1	
	USB port	2 x USB 2.0	
Serial port	1 (COM1)		
<b>Internal connector</b>	COM port header	1 (COM2)	
	Auxiliary panel header	1 (include chassis intrusion , location button & LED, front LAN LED)	
	TPM header	1	
	IPMB header	1	
	Buzzer	1	
	Fan header	"8 x 4-pin" or "6 x 4-pin and 2 x 3-pin" *CPU fan header have 3-pin and 4-pin, only one of them can be used at a time.	
	ATX power	1 (24-pin) + 2(8-pin)	
	USB header	2 (each support 2 USB 2.0)	
	Type A USB 2.0 port	1	

<b>Internal connector</b>	80 debug port LED	1
	Front panel	1
	Speaker (4pin)	1
<b>Support OS</b>	OS	<b>EP2C606-4L</b>
		<b>Microsoft® Windows®:</b> Windows 2003 32/64 (IDE mode) Windows 2003 R2 32/64 (IDE/AHCI mode) Windows 2008 32/64 Windows 2008 R2  <b>Linux:</b> RedHad Enterprise Linux Server 5.5 32/64 (AHCI mode) RedHad Enterprise Linux Server 6.0 32/64 (AHCI mode) CentOS 5.5 32/64 (AHCI mode) CentOS 6.0 32/64 (AHCI mode) Suse 10.3 32/64 (AHCI mode) Suse 11.1 32/64 (AHCI mode)
		<b>EP2C602-4L / EP2C602</b>
		<b>Microsoft® Windows®:</b> Windows 2003 32/64 (IDE mode) Windows 2003 R2 32/64 (IDE/AHCI mode) Windows 2008 32/64 Windows 2008 R2 Windows 2012 Windows 2012 R2  <b>Linux:</b> RedHad Enterprise Linux Server 5.5 32/64 (AHCI mode) RedHad Enterprise Linux Server 6.0 32/64 (AHCI mode) CentOS 5.5 32/64 (AHCI mode) CentOS 6.0 32/64 (AHCI mode) Suse 10.3 32/64 (AHCI mode) Suse 11.1 32/64 (AHCI mode)

\* For detailed product information, please visit our website:

<http://www.asrockrack.com>

\* EP2C606-4L is build-to-order manufacturing.

# 1.4 Motherboard Layout

## EP2C606-4L/D16

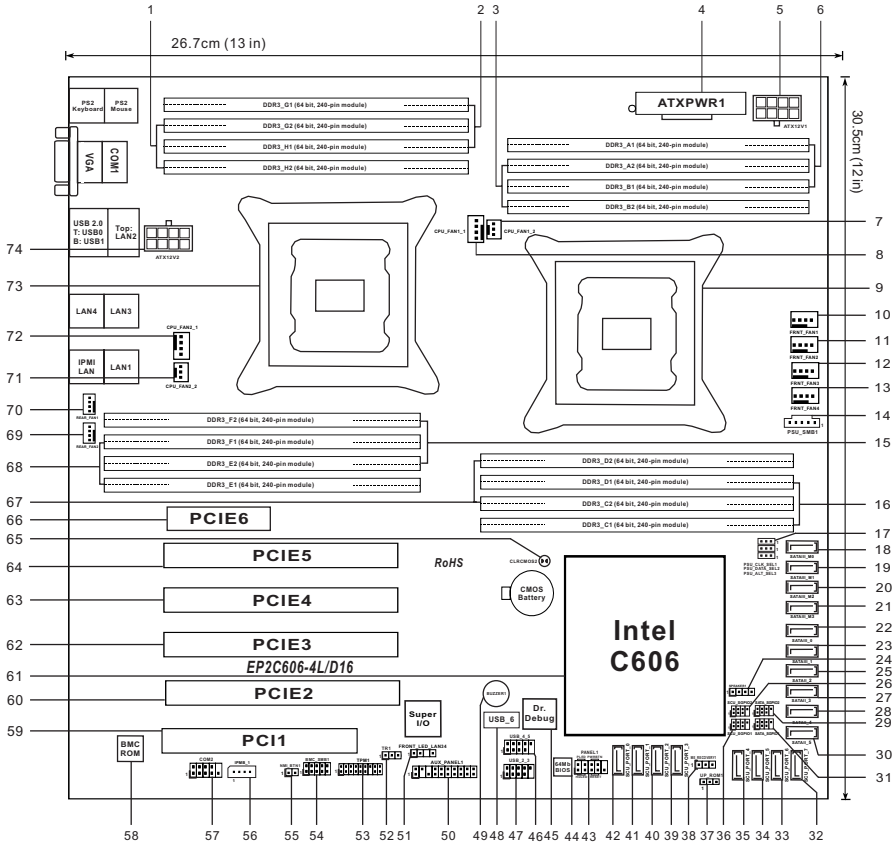

<b>1</b>	2 x 240-pin DDR3 DIMM Slots (DDR3_G2, DDR3_H2, White)
<b>2</b>	2 x 240-pin DDR3 DIMM Slots (DDR3_G1, DDR3_H1, Blue)
<b>3</b>	2 x 240-pin DDR3 DIMM Slots (DDR3_A2, DDR3_B2, White)
<b>4</b>	ATX Power Connector (ATXPWR1)
<b>5</b>	ATX 12V Power Connector (ATX12V1)
<b>6</b>	2 x 240-pin DDR3 DIMM Slots (DDR3_A1, DDR3_B1, Blue)
<b>7</b>	CPU Fan Connector (CPU_FAN1_2)
<b>8</b>	CPU Fan Connector (CPU_FAN1_1)
<b>9</b>	2011-Pin CPU Socket (CPU_BSP1)
<b>10</b>	Front Fan Connector (FRNT_FAN1)
<b>11</b>	Front Fan Connector (FRNT_FAN2)
<b>12</b>	Front Fan Connector (FRNT_FAN3)
<b>13</b>	Front Fan Connector (FRNT_FAN4)
<b>14</b>	PSU SMBus (PSU_SMB1)
<b>15</b>	2 x 240-pin DDR3 DIMM Slots (DDR3_F2, DDR3_E2, White)
<b>16</b>	2 x 240-pin DDR3 DIMM Slots (DDR3_D1, DDR3_C1, Blue)
<b>17</b>	PSU Jumpers (PSU_CLK_SEL1, PSU_DATA_SEL2, PSU_ALT_SEL3)
<b>18</b>	SATA3 Connector (SATAIII_M0, White)
<b>19</b>	SATA3 Connector (SATAIII_M1, White)
<b>20</b>	SATA3 Connector (SATAIII_M2, White)
<b>21</b>	SATA3 Connector (SATAIII_M3, White)
<b>22</b>	SATA3 Connector (SATAIII_0, White)
<b>23</b>	SATA3 Connector (SATAIII_1, White)
<b>24</b>	Speaker Header (SPEAKER1)
<b>25</b>	SATA2 Connector (SATAII_2, Blue)
<b>26</b>	SCU SGPIO Connector (SCU_SGPIO2)
<b>27</b>	SATA2 Connector (SATAII_3, Blue)
<b>28</b>	SATA2 Connector (SATAII_4, Blue)

29	SATA SGPIO Connector (SATA_SGPIO2)
30	SATA2 Connector (SATAII_5, Blue)
31	SATA SGPIO Connector (SATA_SGPIO1)
32	SCU Connector (SCU_PORT_7, Black)
33	SCU Connector (SCU_PORT_6, Black)
34	SCU Connector (SCU_PORT_5, Black)
35	SCU Connector (SCU_PORT_4, Black)
36	SCU SGPIO Connector (SCU_SGPIO1)
37	UP ROM Header (UP_ROM1)
38	ME Recovery Jumper (ME_RECOVERY1)
39	SCU Connector (SCU_PORT_3, Black)
40	SCU Connector (SCU_PORT_2, Black)
41	SCU Connector (SCU_PORT_1, Black)
42	SCU Connector (SCU_PORT_0, Black)
43	System Panel Header (PANEL1)
44	SPI Flash Memory (64Mb)
45	Dr. Debug
46	USB 2.0 Ports (USB_4_5)
47	USB 2.0 Ports (USB_2_3)
48	USB 2.0 Ports (USB_6)
49	Buzzer (BUZZER1)
50	Auxiliary panel header (AUX_PANEL1)
51	Front Lan LED Connector (FRONT_LED_LAN34)
52	Thermal Sensor header (TR1)
53	TPM Header (TPM1)
54	BMC SMB Header (BMC_SMB1)
55	Non Maskable Interrupt Button (NMI_BTN1)
56	Intelligent Platform Management Bus header (IPMB_1)
57	COM Port Header (COM2)
58	BMC ROM
59	PCI Slot (PCI1, White)
60	PCI Express 3.0 x16 Slot (PCIE2, Blue) from CPU_BSP1
61	Intel C606 Chipset
62	PCI Express 3.0 x16 Slot (PCIE3, Blue) from CPU_BSP1
63	PCI Express 3.0 x16 Slot (PCIE4, Blue) from CPU_BSP1

---

<b>64</b>	PCI Express 3.0 x16 Slot (PCIe5, Blue) from CPU_AP1
<b>65</b>	Clear CMOS Pad (CLRCMOS2)
<b>66</b>	PCI Express 2.0 x 4 Slot (PCIe6, White) from CPU_BSP1
<b>67</b>	2 x 240-pin DDR3 DIMM Slots (DDR3_D2, DDR3_C2, White)
<b>68</b>	2 x 240-pin DDR3 DIMM Slots (DDR3_F1, DDR3_E1, Blue)
<b>69</b>	Rear Fan Connector (REAR_FAN2)
<b>70</b>	Rear Fan Connector (REAR_FAN1)
<b>71</b>	CPU Fan Connector (CPU_FAN2_2)
<b>72</b>	CPU Fan Connector (CPU_FAN2_1)
<b>73</b>	2011-Pin CPU Socket (CPU_AP1)
<b>74</b>	ATX 12V Power Connector (ATX12V2)

# EP2C602-4L/D16

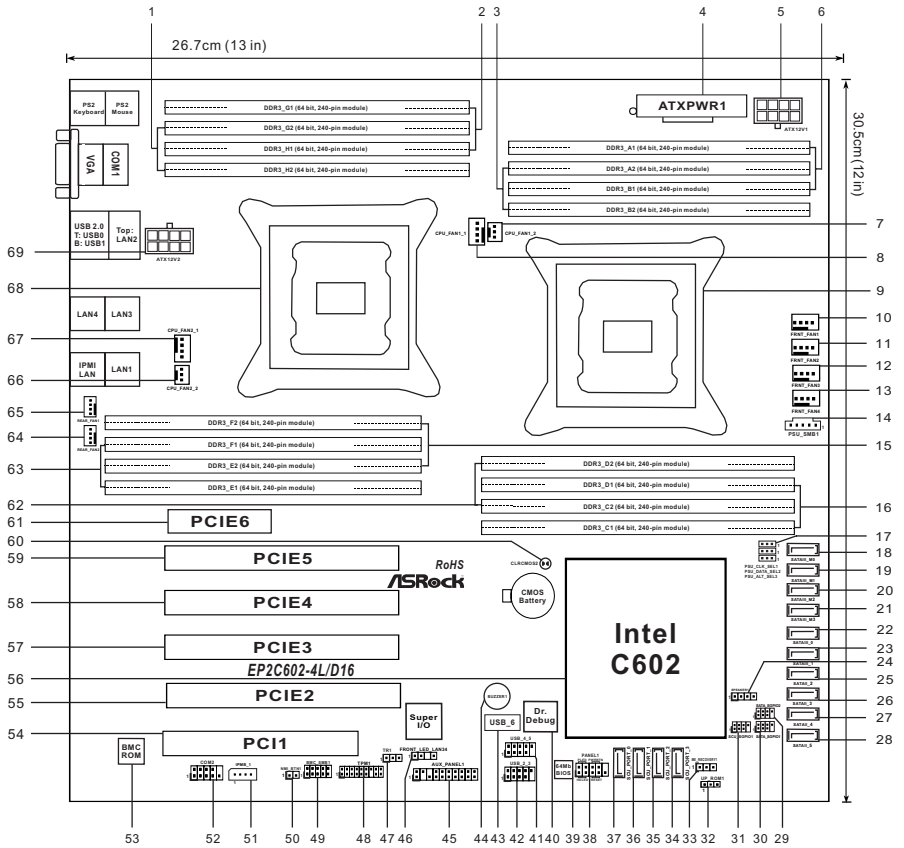



<b>1</b>	2 x 240-pin DDR3 DIMM Slots (DDR3_G2, DDR3_H2, White)
<b>2</b>	2 x 240-pin DDR3 DIMM Slots (DDR3_G1, DDR3_H1, Blue)
<b>3</b>	2 x 240-pin DDR3 DIMM Slots (DDR3_A2, DDR3_B2, White)
<b>4</b>	ATX Power Connector (ATXPWR1)
<b>5</b>	ATX 12V Power Connector (ATX12V1)
<b>6</b>	2 x 240-pin DDR3 DIMM Slots (DDR3_A1, DDR3_B1, Blue)
<b>7</b>	CPU Fan Connector (CPU_FAN1_2)
<b>8</b>	CPU Fan Connector (CPU_FAN1_1)
<b>9</b>	2011-Pin CPU Socket (CPU_BSP1)
<b>10</b>	Front Fan Connector (FRNT_FAN1)
<b>11</b>	Front Fan Connector (FRNT_FAN2)
<b>12</b>	Front Fan Connector (FRNT_FAN3)
<b>13</b>	Front Fan Connector (FRNT_FAN4)
<b>14</b>	PSU SMBus (PSU_SMB1)
<b>15</b>	2 x 240-pin DDR3 DIMM Slots (DDR3_F2, DDR3_E2, White)
<b>16</b>	2 x 240-pin DDR3 DIMM Slots (DDR3_D1, DDR3_C1, Blue)
<b>17</b>	PSU Jumpers (PSU_CLK_SEL1, PSU_DATA_SEL2, PSU_ALT_SEL3)
<b>18</b>	SATA3 Connector (SATAIII_M0, White)
<b>19</b>	SATA3 Connector (SATAIII_M1, White)
<b>20</b>	SATA3 Connector (SATAIII_M2, White)
<b>21</b>	SATA3 Connector (SATAIII_M3, White)
<b>22</b>	SATA3 Connector (SATAIII_0, White)
<b>23</b>	SATA3 Connector (SATAIII_1, White)
<b>24</b>	Speaker Header (SPEAKER1)
<b>25</b>	SATA2 Connector (SATAII_2, Blue)
<b>26</b>	SATA2 Connector (SATAII_3, Blue)
<b>27</b>	SATA2 Connector (SATAII_4, Blue)
<b>28</b>	SATA2 Connector (SATAII_5, Blue)

29	SATA SGPIO Connector (SATA_SGPIO2)
30	SATA SGPIO Connector (SATA_SGPIO1)
31	SCU SGPIO Connector (SCU_SGPIO1)
32	UP ROM Header (UP_ROM1)
33	ME Recovery Jumper (ME_RECOVERY1)
34	SCU Connector (SCU_PORT_3, Blue)
35	SCU Connector (SCU_PORT_2, Blue)
36	SCU Connector (SCU_PORT_1, Blue)
37	SCU Connector (SCU_PORT_0, Blue)
38	System Panel Header (PANEL1)
39	SPI Flash Memory (64Mb)
40	Dr. Debug
41	USB 2.0 Ports (USB_4_5)
42	USB 2.0 Ports (USB_2_3)
43	USB 2.0 Ports (USB_6)
44	Buzzer (BUZZER1)
45	Auxiliary panel header (AUX_PANEL1)
46	Front Lan LED Connector (FRONT_LED_LAN34)
47	Thermal Sensor header (TR1)
48	TPM Header (TPM1)
49	BMC SMB Header (BMC_SMB1)
50	Non Maskable Interrupt Button (NMI_BTN1)
51	Intelligent Platform Management Bus header (IPMB_1)
52	COM Port Header (COM2)
53	BMC ROM
54	PCI Slot (PCI1, White)
55	PCI Express 3.0 x16 Slot (PCIE2, Blue) from CPU_BSP1
56	Intel C602 Chipset
57	PCI Express 3.0 x16 Slot (PCIE3, Blue) from CPU_BSP1
58	PCI Express 3.0 x16 Slot (PCIE4, Blue) from CPU_BSP1
59	PCI Express 3.0 x16 Slot (PCIE5, Blue) from CPU_AP1
60	Clear CMOS Pad (CLRCMOS2)
61	PCI Express 3.0 x 4 Slot (PCIE6, White) from CPU_BSP1
62	2 x 240-pin DDR3 DIMM Slots (DDR3_D2, DDR3_C2, White)

---

<b>63</b>	2 x 240-pin DDR3 DIMM Slots (DDR3_F1, DDR3_E1, Blue)
<b>64</b>	Rear Fan Connector (REAR_FAN2)
<b>65</b>	Rear Fan Connector (REAR_FAN1)
<b>66</b>	CPU Fan Connector (CPU_FAN2_2)
<b>67</b>	CPU Fan Connector (CPU_FAN2_1)
<b>68</b>	2011-Pin CPU Socket (CPU_AP1)
<b>69</b>	ATX 12V Power Connector (ATX12V2)

# EP2C602/D16

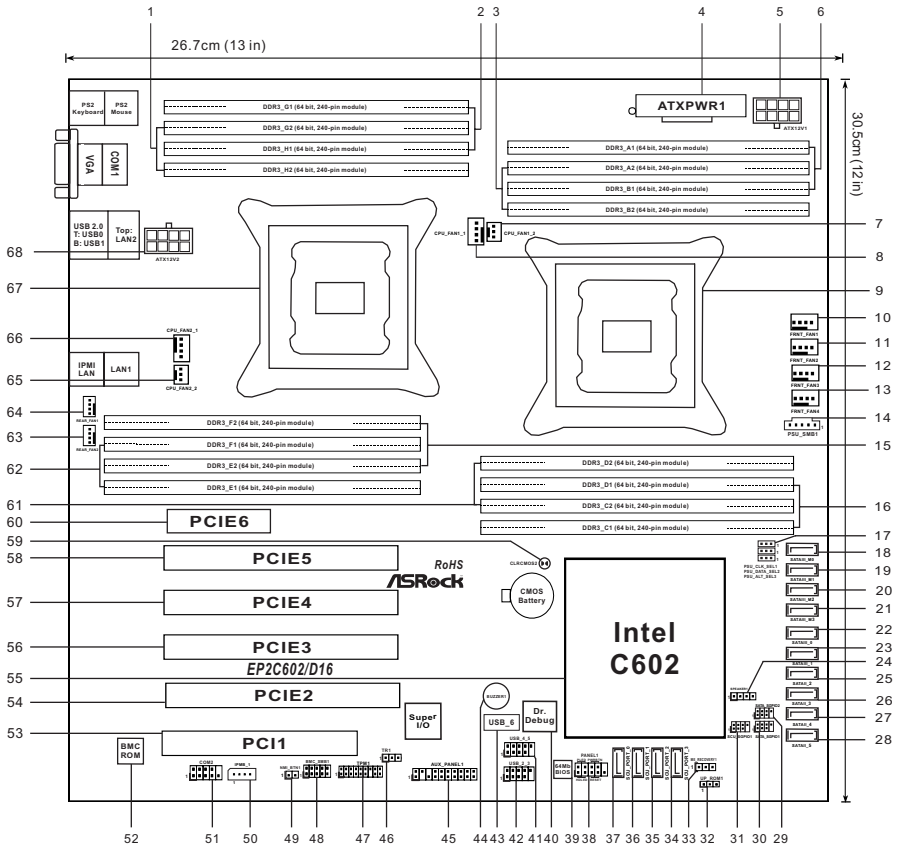

<b>1</b>	2 x 240-pin DDR3 DIMM Slots (DDR3_G2, DDR3_H2, White)
<b>2</b>	2 x 240-pin DDR3 DIMM Slots (DDR3_G1, DDR3_H1, Blue)
<b>3</b>	2 x 240-pin DDR3 DIMM Slots (DDR3_A2, DDR3_B2, White)
<b>4</b>	ATX Power Connector (ATXPWR1)
<b>5</b>	ATX 12V Power Connector (ATX12V1)
<b>6</b>	2 x 240-pin DDR3 DIMM Slots (DDR3_A1, DDR3_B1, Blue)
<b>7</b>	CPU Fan Connector (CPU_FAN1_2)
<b>8</b>	CPU Fan Connector (CPU_FAN1_1)
<b>9</b>	2011-Pin CPU Socket (CPU_BSP1)
<b>10</b>	Front Fan Connector (FRNT_FAN1)
<b>11</b>	Front Fan Connector (FRNT_FAN2)
<b>12</b>	Front Fan Connector (FRNT_FAN3)
<b>13</b>	Front Fan Connector (FRNT_FAN4)
<b>14</b>	PSU SMBus (PSU_SMB1)
<b>15</b>	2 x 240-pin DDR3 DIMM Slots (DDR3_F2, DDR3_E2, White)
<b>16</b>	2 x 240-pin DDR3 DIMM Slots (DDR3_D1, DDR3_C1, Blue)
<b>17</b>	PSU Jumpers (PSU_CLK_SEL1, PSU_DATA_SEL2, PSU_ALT_SEL3)
<b>18</b>	SATA3 Connector (SATAIII_M0, White)
<b>19</b>	SATA3 Connector (SATAIII_M1, White)
<b>20</b>	SATA3 Connector (SATAIII_M2, White)
<b>21</b>	SATA3 Connector (SATAIII_M3, White)
<b>22</b>	SATA3 Connector (SATAIII_0, White)
<b>23</b>	SATA3 Connector (SATAIII_1, White)
<b>24</b>	Speaker Header (SPEAKER1)
<b>25</b>	SATA2 Connector (SATAII_2, Blue)
<b>26</b>	SATA2 Connector (SATAII_3, Blue)
<b>27</b>	SATA2 Connector (SATAII_4, Blue)
<b>28</b>	SATA2 Connector (SATAII_5, Blue)

29	SATA SGPIO Connector (SATA_SGPIO2)
30	SATA SGPIO Connector (SATA_SGPIO1)
31	SCU SGPIO Connector (SCU_SGPIO1)
32	UP ROM Header (UP_ROM1)
33	ME Recovery Jumper (ME_RECOVERY1)
34	SCU Connector (SCU_PORT_3, Blue)
35	SCU Connector (SCU_PORT_2, Blue)
36	SCU Connector (SCU_PORT_1, Blue)
37	SCU Connector (SCU_PORT_0, Blue)
38	System Panel Header (PANEL1)
39	SPI Flash Memory (64Mb)
40	Dr. Debug
41	USB 2.0 Ports (USB_4_5)
42	USB 2.0 Ports (USB_2_3)
43	USB 2.0 Ports (USB_6)
44	Buzzer (BUZZER1)
45	Auxiliary panel header (AUX_PANEL1)
46	Thermal Sensor header (TR1)
47	TPM Header (TPM1)
48	BMC SMB Header (BMC_SMB1)
49	Non Maskable Interrupt Button (NMI_BTN1)
50	Intelligent Platform Management Bus header (IPMB_1)
51	COM Port Header (COM2)
52	BMC ROM
53	PCI Slot (PCI1, White)
54	PCI Express 3.0 x16 Slot (PCIE2, Blue) from CPU_BSP1
55	Intel C602 Chipset
56	PCI Express 3.0 x16 Slot (PCIE3, Blue) from CPU_BSP1
57	PCI Express 3.0 x16 Slot (PCIE4, Blue) from CPU_BSP1
58	PCI Express 3.0 x16 Slot (PCIE5, Blue) from CPU_AP1
59	Clear CMOS Pad (CLRCMOS2)
60	PCI Express 3.0 x 4 Slot (PCIE6, White) from CPU_BSP1
61	2 x 240-pin DDR3 DIMM Slots (DDR3_D2, DDR3_C2, White)
62	2 x 240-pin DDR3 DIMM Slots

---

	(DDR3_F1, DDR3_E1, Blue)
<b>63</b>	Rear Fan Connector (REAR_FAN2)
<b>64</b>	Rear Fan Connector (REAR_FAN1)
<b>65</b>	CPU Fan Connector (CPU_FAN2_2)
<b>66</b>	CPU Fan Connector (CPU_FAN2_1)
<b>67</b>	2011-Pin CPU Socket (CPU_AP1)
<b>68</b>	ATX 12V Power Connector (ATX12V2)

# EP2C606-4L

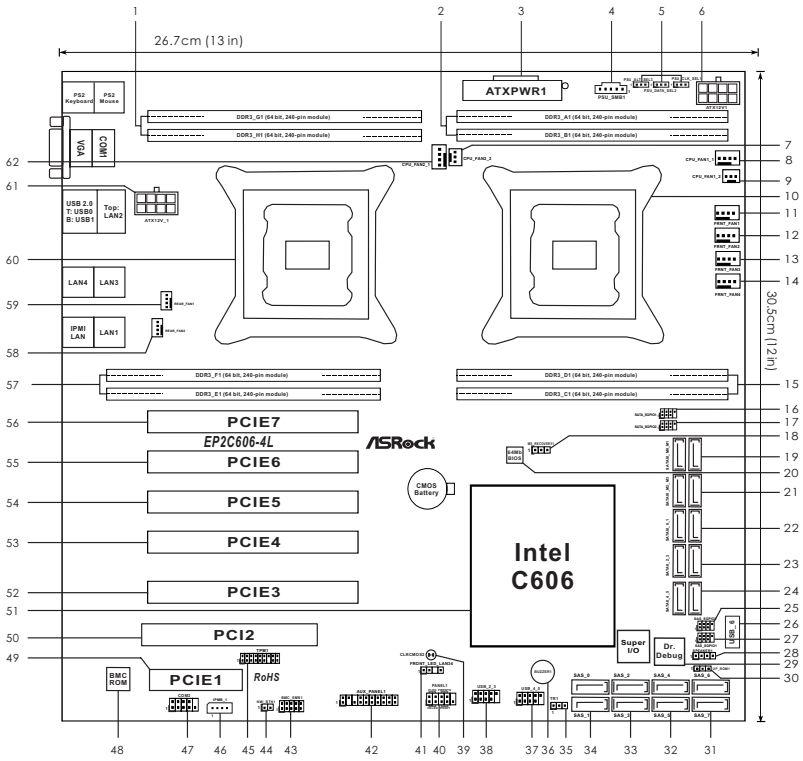



<b>1</b>	2 x 240-pin DDR3 DIMM Slots (DDR3_G1, DDR3_H1, Blue)
<b>2</b>	2 x 240-pin DDR3 DIMM Slots (DDR3_A1, DDR3_B1, White)
<b>3</b>	ATX Power Connector (ATXPWR1)
<b>4</b>	PSU SMBus (PSU_SMB1)
<b>5</b>	PSU Jumpers (PSU_CLK_SEL1, PSU_DATA_SEL2, PSU_ALT_SEL3)
<b>6</b>	ATX 12V Power Connector (ATX12V1)
<b>7</b>	CPU Fan Connector (CPU_FAN2_2)
<b>8</b>	CPU Fan Connector (CPU_FAN1_1)
<b>9</b>	CPU Fan Connector (CPU_FAN1_2)
<b>10</b>	2011-Pin CPU Socket (CPU_BSP1)
<b>11</b>	Front Fan Connector (FRNT_FAN1)
<b>12</b>	Front Fan Connector (FRNT_FAN2)
<b>13</b>	Front Fan Connector (FRNT_FAN3)
<b>14</b>	Front Fan Connector (FRNT_FAN4)
<b>15</b>	2 x 240-pin DDR3 DIMM Slots (DDR3_D1, DDR3_C1, Blue)
<b>16</b>	SATA SGPIO Connector (SATA_SGPIO1)
<b>17</b>	SATA SGPIO Connector (SATA_SGPIO2)
<b>18</b>	ME Recovery Jumper (ME_RECOVERY1)
<b>19</b>	SATA3 Connector (SATAIII_M0_M1, White)
<b>20</b>	SPI Flash Memory (64Mb)
<b>21</b>	SATA3 Connector (SATAIII_M2_M3, White)
<b>22</b>	SATA3 Connector (SATAIII_0_1, White)
<b>23</b>	SATA2 Connector (SATAII_2_3, Blue)
<b>24</b>	SATA2 Connector (SATAII_4_5, Blue)
<b>25</b>	SAS Connector (SAS_SGPIO2)
<b>26</b>	USB 2.0 Ports (USB_6)
<b>27</b>	SAS Connector (SAS_SGPIO1)
<b>28</b>	Speaker Header (SPEAKER1)
<b>29</b>	Dr. Debug
<b>30</b>	UP ROM Header (UP_ROM1)
<b>31</b>	SAS Connector (SAS_6_7, Black)

<b>32</b>	SAS Connector (SAS_4_5, Black)
<b>33</b>	SAS Connector (SAS_2_3, Black)
<b>34</b>	SAS Connector (SAS_0_1, Black)
<b>35</b>	Thermal Sensor header (TR1)
<b>36</b>	Buzzer (BUZZER1)
<b>37</b>	USB 2.0 Ports (USB_4_5)
<b>38</b>	USB 2.0 Ports (USB_2_3)
<b>39</b>	Clear CMOS Pad (CLRCMOS2)
<b>40</b>	System Panel Header (PANEL1)
<b>41</b>	Front Lan LED Connector (FRONT_LED_LAN34)
<b>42</b>	Auxiliary panel header (AUX_PANEL1)
<b>43</b>	BMC SMB Header (BMC_SMB1)
<b>44</b>	Non Maskable Interrupt Button (NMI_BTN1)
<b>45</b>	TPM Header (TPM1)
<b>46</b>	Intelligent Platform Management Bus header (IPMB_1)
<b>47</b>	COM Port Header (COM2)
<b>48</b>	BMC ROM
<b>49</b>	PCI Express 3.0 x 4 Slot (PCIE1, White) from CPU_BSP1
<b>50</b>	PCI Slot (PCI2, White)
<b>51</b>	Intel C602 Chipset
<b>52</b>	PCI Express 3.0 x16 Slot (PCIE3, Blue) from CPU_BSP1
<b>53</b>	PCI Express 3.0 x16 Slot (PCIE4, Blue) from CPU_BSP1
<b>54</b>	PCI Express 3.0 x16 Slot (PCIE5, Blue) from CPU_BSP1
<b>55</b>	PCI Express 3.0 x16 Slot (PCIE6, Blue) from CPU_AP1
<b>56</b>	PCI Express 3.0 x16 Slot (PCIE7, Blue) from CPU_AP1
<b>57</b>	2 x 240-pin DDR3 DIMM Slots (DDR3_F1, DDR3_E1, Blue)
<b>58</b>	Rear Fan Connector (REAR_FAN2)
<b>59</b>	Rear Fan Connector (REAR_FAN1)
<b>60</b>	2011-Pin CPU Socket (CPU_AP1)
<b>61</b>	ATX 12V Power Connector (ATX12V_1)
<b>62</b>	CPU Fan Connector (CPU_FAN2_1)

# EP2C602-4L

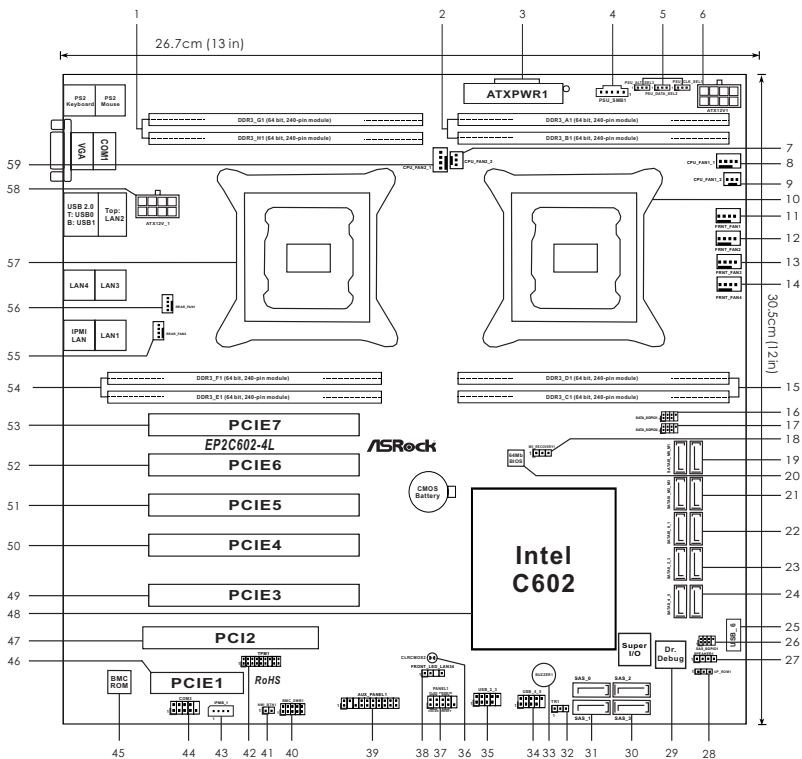

<b>1</b>	2 x 240-pin DDR3 DIMM Slots (DDR3_G1, DDR3_H1, Blue)
<b>2</b>	2 x 240-pin DDR3 DIMM Slots (DDR3_A1, DDR3_B1, White)
<b>3</b>	ATX Power Connector (ATXPWR1)
<b>4</b>	PSU SMBus (PSU_SMB1)
<b>5</b>	PSU Jumpers (PSU_CLK_SEL1, PSU_DATA_SEL2, PSU_ALT_SEL3)
<b>6</b>	ATX 12V Power Connector (ATX12V1)
<b>7</b>	CPU Fan Connector (CPU_FAN2_2)
<b>8</b>	CPU Fan Connector (CPU_FAN1_1)
<b>9</b>	CPU Fan Connector (CPU_FAN1_2)
<b>10</b>	2011-Pin CPU Socket (CPU_BSP1)
<b>11</b>	Front Fan Connector (FRNT_FAN1)
<b>12</b>	Front Fan Connector (FRNT_FAN2)
<b>13</b>	Front Fan Connector (FRNT_FAN3)
<b>14</b>	Front Fan Connector (FRNT_FAN4)
<b>15</b>	2 x 240-pin DDR3 DIMM Slots (DDR3_D1, DDR3_C1, Blue)
<b>16</b>	SATA SGPIO Connector (SATA_SGPIO1)
<b>17</b>	SATA SGPIO Connector (SATA_SGPIO2)
<b>18</b>	ME Recovery Jumper (ME_RECOVERY1)
<b>19</b>	SATA3 Connector (SATAIII_M0_M1, White)
<b>20</b>	SPI Flash Memory (64Mb)
<b>21</b>	SATA3 Connector (SATAIII_M2_M3, White)
<b>22</b>	SATA3 Connector (SATAIII_0_1, White)
<b>23</b>	SATA2 Connector (SATAII_2_3, Blue)
<b>24</b>	SATA2 Connector (SATAII_4_5, Blue)
<b>25</b>	USB 2.0 Ports (USB_6)
<b>26</b>	SAS Connector (SAS_SGPIO1)
<b>27</b>	Speaker Header (SPEAKER1)
<b>28</b>	UP ROM Header (UP_ROM1)
<b>29</b>	Dr. Debug
<b>30</b>	SAS Connector (SAS_2_3, Blue)
<b>31</b>	SAS Connector (SAS_0_1, Blue)

---

<b>32</b>	Thermal Sensor header (TR1)
<b>33</b>	Buzzer (BUZZER1)
<b>34</b>	USB 2.0 Ports (USB_4_5)
<b>35</b>	USB 2.0 Ports (USB_2_3)
<b>36</b>	Clear CMOS Pad (CLRCMOS2)
<b>37</b>	System Panel Header (PANEL1)
<b>38</b>	Front Lan LED Connector (FRONT_LED_LAN34)
<b>39</b>	Auxiliary panel header (AUX_PANEL1)
<b>40</b>	BMC SMB Header (BMC_SMB1)
<b>41</b>	Non Maskable Interrupt Button (NMI_BTN1)
<b>42</b>	TPM Header (TPM1)
<b>43</b>	Intelligent Platform Management Bus header (IPMB_1)
<b>44</b>	COM Port Header (COM2)
<b>45</b>	BMC ROM
<b>46</b>	PCI Express 3.0 x 4 Slot (PCIE1, White) from CPU_BSP1
<b>47</b>	PCI Slot (PCI2, White)
<b>48</b>	Intel C602 Chipset
<b>49</b>	PCI Express 3.0 x16 Slot (PCIE3, Blue) from CPU_BSP1
<b>50</b>	PCI Express 3.0 x16 Slot (PCIE4, Blue) from CPU_BSP1
<b>51</b>	PCI Express 3.0 x16 Slot (PCIE5, Blue) from CPU_BSP1
<b>52</b>	PCI Express 3.0 x16 Slot (PCIE6, Blue) from CPU_AP1
<b>53</b>	PCI Express 3.0 x16 Slot (PCIE7, Blue) from CPU_AP1
<b>54</b>	2 x 240-pin DDR3 DIMM Slots (DDR3_F1, DDR3_E1, Blue)
<b>55</b>	Rear Fan Connector (REAR_FAN2)
<b>56</b>	Rear Fan Connector (REAR_FAN1)
<b>57</b>	2011-Pin CPU Socket (CPU_AP1)
<b>58</b>	ATX 12V Power Connector (ATX12V_1)
<b>59</b>	CPU Fan Connector (CPU_FAN2_1)

---

# EP2C602

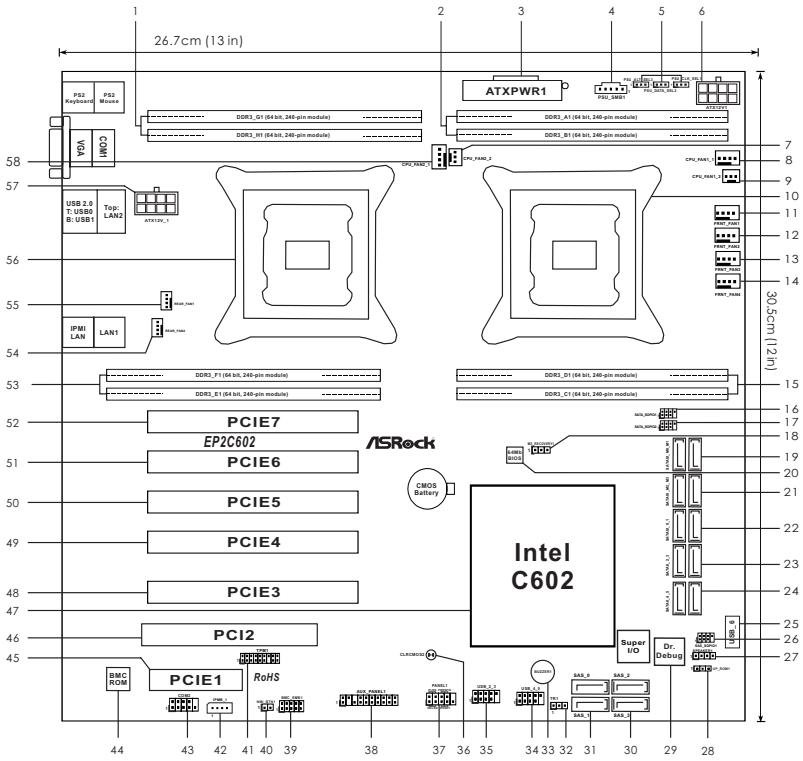

<b>1</b>	2 x 240-pin DDR3 DIMM Slots (DDR3_G1, DDR3_H1, Blue)
<b>2</b>	2 x 240-pin DDR3 DIMM Slots (DDR3_A1, DDR3_B1, White)
<b>3</b>	ATX Power Connector (ATXPWR1)
<b>4</b>	PSU SMBus (PSU_SMB1)
<b>5</b>	PSU Jumpers (PSU_CLK_SEL1, PSU_DATA_SEL2, PSU_ALT_SEL3)
<b>6</b>	ATX 12V Power Connector (ATX12V1)
<b>7</b>	CPU Fan Connector (CPU_FAN2_2)
<b>8</b>	CPU Fan Connector (CPU_FAN1_1)
<b>9</b>	CPU Fan Connector (CPU_FAN1_2)
<b>10</b>	2011-Pin CPU Socket (CPU_BSP1)
<b>11</b>	Front Fan Connector (FRNT_FAN1)
<b>12</b>	Front Fan Connector (FRNT_FAN2)
<b>13</b>	Front Fan Connector (FRNT_FAN3)
<b>14</b>	Front Fan Connector (FRNT_FAN4)
<b>15</b>	2 x 240-pin DDR3 DIMM Slots (DDR3_D1, DDR3_C1, Blue)
<b>16</b>	SATA SGPIO Connector (SATA_SGPIO1)
<b>17</b>	SATA SGPIO Connector (SATA_SGPIO2)
<b>18</b>	ME Recovery Jumper (ME_RECOVERY1)
<b>19</b>	SATA3 Connector (SATAIII_M0_M1, White)
<b>20</b>	SPI Flash Memory (64Mb)
<b>21</b>	SATA3 Connector (SATAIII_M2_M3, White)
<b>22</b>	SATA3 Connector (SATAIII_0_1, White)
<b>23</b>	SATA2 Connector (SATAII_2_3, Blue)
<b>24</b>	SATA2 Connector (SATAII_4_5, Blue)
<b>25</b>	USB 2.0 Ports (USB_6)
<b>26</b>	SAS Connector (SAS_SGPIO1)
<b>27</b>	Speaker Header (SPEAKER1)
<b>28</b>	UP ROM Header (UP_ROM1)
<b>29</b>	Dr. Debug
<b>30</b>	SAS Connector (SAS_2_3, Blue)
<b>31</b>	SAS Connector (SAS_0_1, Blue)

---

<b>32</b>	Thermal Sensor header (TR1)
<b>33</b>	Buzzer (BUZZER1)
<b>34</b>	USB 2.0 Ports (USB_4_5)
<b>35</b>	USB 2.0 Ports (USB_2_3)
<b>36</b>	Clear CMOS Pad (CLRCMOS2)
<b>37</b>	System Panel Header (PANEL1)
<b>38</b>	Auxiliary panel header (AUX_PANEL1)
<b>39</b>	BMC SMB Header (BMC_SMB1)
<b>40</b>	Non Maskable Interrupt Button (NMI_BTN1)
<b>41</b>	TPM Header (TPM1)
<b>42</b>	Intelligent Platform Management Bus header (IPMB_1)
<b>43</b>	COM Port Header (COM2)
<b>44</b>	BMC ROM
<b>45</b>	PCI Express 3.0 x 4 Slot (PCIE1, White) from CPU_BSP1
<b>46</b>	PCI Slot (PCI2, White)
<b>47</b>	Intel C602 Chipset
<b>48</b>	PCI Express 3.0 x16 Slot (PCIE3, Blue) from CPU_BSP1
<b>49</b>	PCI Express 3.0 x16 Slot (PCIE4, Blue) from CPU_BSP1
<b>50</b>	PCI Express 3.0 x16 Slot (PCIE5, Blue) from CPU_BSP1
<b>51</b>	PCI Express 3.0 x16 Slot (PCIE6, Blue) from CPU_AP1
<b>52</b>	PCI Express 3.0 x16 Slot (PCIE7, Blue) from CPU_AP1
<b>53</b>	2 x 240-pin DDR3 DIMM Slots (DDR3_F1, DDR3_E1, Blue)
<b>54</b>	Rear Fan Connector (REAR_FAN2)
<b>55</b>	Rear Fan Connector (REAR_FAN1)
<b>56</b>	2011-Pin CPU Socket (CPU_AP1)
<b>57</b>	ATX 12V Power Connector (ATX12V_1)
<b>58</b>	CPU Fan Connector (CPU_FAN2_1)

---



## 1.5 I/O Panel

### EP2C606-4L/D16

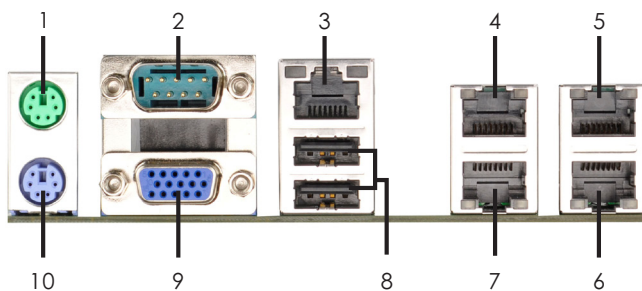

- 1 PS/2 Mouse Port (Green)**
- 2 Serial Port (COM1)**
- \* 3 LAN RJ-45 Port (LAN2)**
- \* 4 LAN RJ-45 Port (LAN3)**
- \* 5 LAN RJ-45 Port (LAN1)**
- \* 6 IPMI LAN Port**
- \* 7 LAN RJ-45 Port (LAN4)**
- 8 USB 2.0 Ports (USB01)**
- 9 D-Sub Port (VGA)**
- 10 PS/2 Keyboard Port (Purple)**

\* There are two LEDs on each LAN port. Please refer to the table below for the LAN port LED indications.

LAN Port LED Indications			
Activity/Link LED		SPEED LED	
Status	Description	Status	Description
Off	No Link	Off	10Mbps connection
Blinking	Data Activity	Orange	100Mbps connection
On	100Mbps connection	Green	1Gbps connection

**ACT/LINK LED**      **SPEED LED**

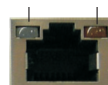

**LAN Port**

## EP2C602-4L/D16

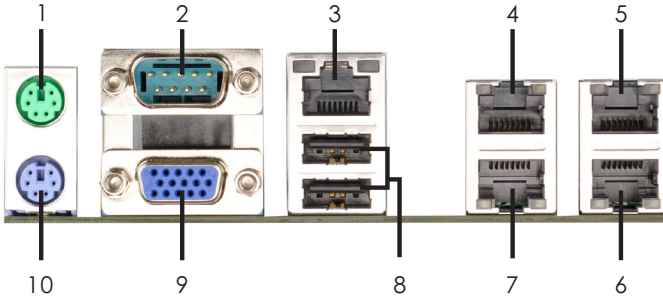

- 1 PS/2 Mouse Port (Green)**
- 2 Serial Port (COM1)**
- \* 3 LAN RJ-45 Port (LAN2)**
- \* 4 LAN RJ-45 Port (LAN3)**
- \* 5 LAN RJ-45 Port (LAN1)**
- \* 6 IPMI LAN Port**
- \* 7 LAN RJ-45 Port (LAN4)**
- 8 USB 2.0 Ports (USB01)**
- 9 D-Sub Port (VGA)**
- 10 PS/2 Keyboard Port (Purple)**

\* There are two LEDs on each LAN port. Please refer to the table below for the LAN port LED indications.

LAN Port LED Indications			
Activity/Link LED		SPEED LED	
Status	Description	Status	Description
Off	No Link	Off	10Mbps connection
Blinking	Data Activity	Orange	100Mbps connection
On	100Mbps connection	Green	1Gbps connection

**ACT/LINK LED**      **SPEED LED**



**LAN Port**

## EP2C602/D16

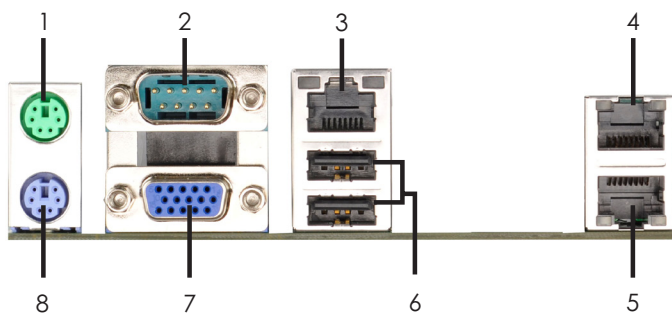

- 1 PS/2 Mouse Port (Green)**
- 2 Serial Port (COM1)**
- \* 3 LAN RJ-45 Port (LAN2)**
- \* 4 LAN RJ-45 Port (LAN1)**
- \* 5 IPMI LAN Port**
- 6 USB 2.0 Ports (USB01)**
- 7 D-Sub Port (VGA)**
- 8 PS/2 Keyboard Port (Purple)**

\* There are two LEDs on each LAN port. Please refer to the table below for the LAN port LED indications.

LAN Port LED Indications			
Activity/Link LED		SPEED LED	
Status	Description	Status	Description
Off	No Link	Off	10Mbps connection
Blinking	Data Activity	Orange	100Mbps connection
On	100Mbps connection	Green	1Gbps connection

**ACT/LINK LED**      **SPEED LED**

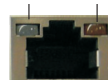

**LAN Port**

## EP2C606-4L

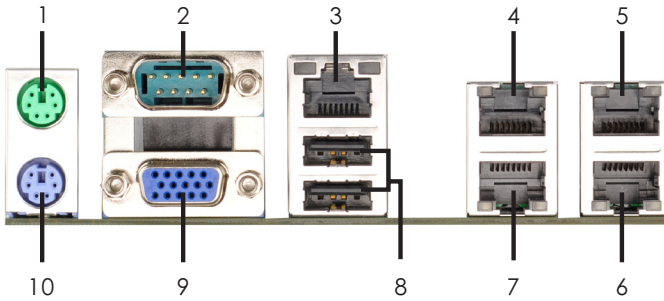

- 1 PS/2 Mouse Port (Green)**
- 2 Serial Port (COM1)**
- \* 3 LAN RJ-45 Port (LAN2)**
- \* 4 LAN RJ-45 Port (LAN3)**
- \* 5 LAN RJ-45 Port (LAN1)**
- \* 6 IPMI LAN Port**
- \* 7 LAN RJ-45 Port (LAN4)**
- 8 USB 2.0 Ports (USB01)**
- 9 D-Sub Port (VGA)**
- 10 PS/2 Keyboard Port (Purple)**

\* There are two LEDs on each LAN port. Please refer to the table below for the LAN port LED indications.

<b>LAN Port LED Indications</b>			
<b>Activity/Link LED</b>		<b>SPEED LED</b>	
Status	Description	Status	Description
Off	No Link	Off	10Mbps connection
Blinking	Data Activity	Orange	100Mbps connection
On	100Mbps connection	Green	1Gbps connection

**ACT/LINK LED**      **SPEED LED**



**LAN Port**

## EP2C602-4L

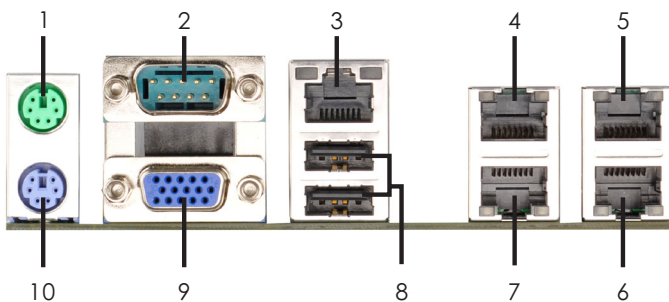

- 1 PS/2 Mouse Port (Green)
- 2 Serial Port (COM1)
- \* 3 LAN RJ-45 Port (LAN2)
- \* 4 LAN RJ-45 Port (LAN3)
- \* 5 LAN RJ-45 Port (LAN1)
- \* 6 IPMI LAN Port
- \* 7 LAN RJ-45 Port (LAN4)
- 8 USB 2.0 Ports (USB01)
- 9 D-Sub Port (VGA)
- 10 PS/2 Keyboard Port (Purple)

\* There are two LEDs on each LAN port. Please refer to the table below for the LAN port LED indications.

LAN Port LED Indications			
Activity/Link LED		SPEED LED	
Status	Description	Status	Description
Off	No Link	Off	10Mbps connection
Blinking	Data Activity	Orange	100Mbps connection
On	100Mbps connection	Green	1Gbps connection

ACT/LINK LED      SPEED LED

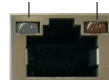

LAN Port

## EP2C602

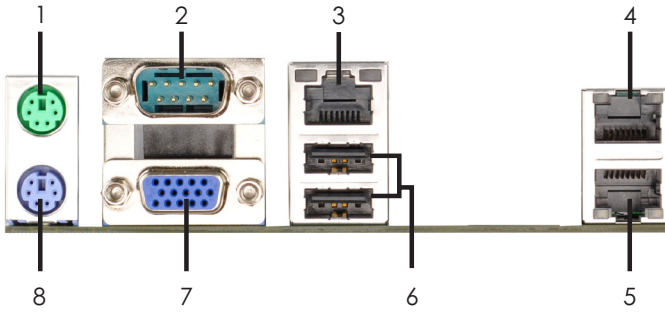

- 1 PS/2 Mouse Port (Green)
- 2 Serial Port (COM1)
- \* 3 LAN RJ-45 Port (LAN2)
- \* 4 LAN RJ-45 Port (LAN1)
- \* 5 IPMI LAN Port
- 6 USB 2.0 Ports (USB01)
- 7 D-Sub Port (VGA)
- 8 PS/2 Keyboard Port (Purple)

\* There are two LEDs on each LAN port. Please refer to the table below for the LAN port LED indications.

LAN Port LED Indications			
Activity/Link LED		SPEED LED	
Status	Description	Status	Description
Off	No Link	Off	10Mbps connection
Blinking	Data Activity	Orange	100Mbps connection
On	100Mbps connection	Green	1Gbps connection

ACT/LINK LED      SPEED LED



LAN Port

# 1.6 Block Diagram

## EP2C606-4L/D16

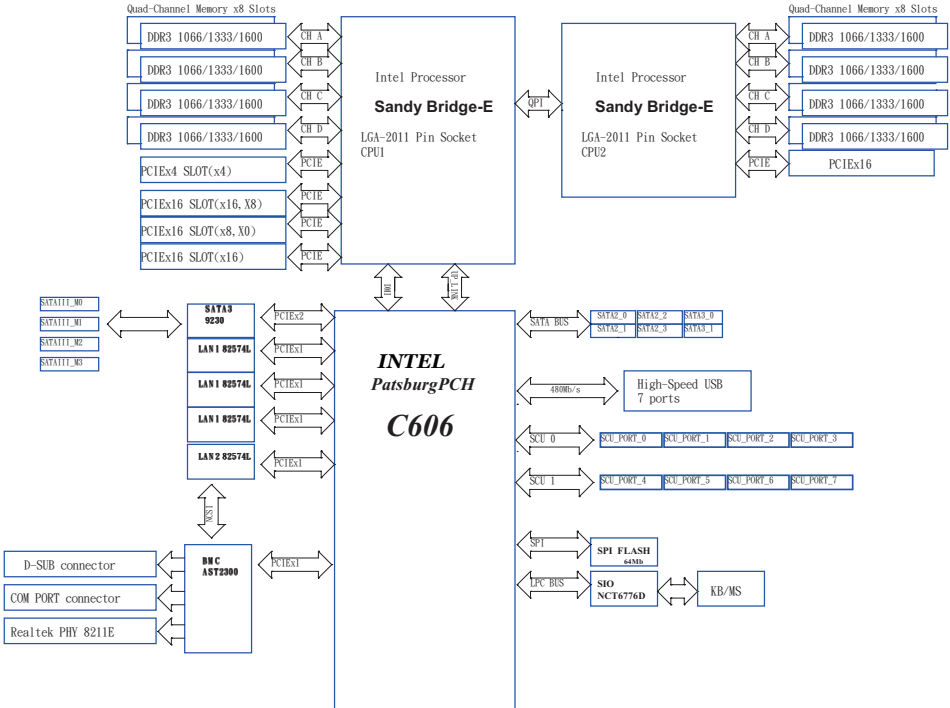

# EP2C602-4L/D16

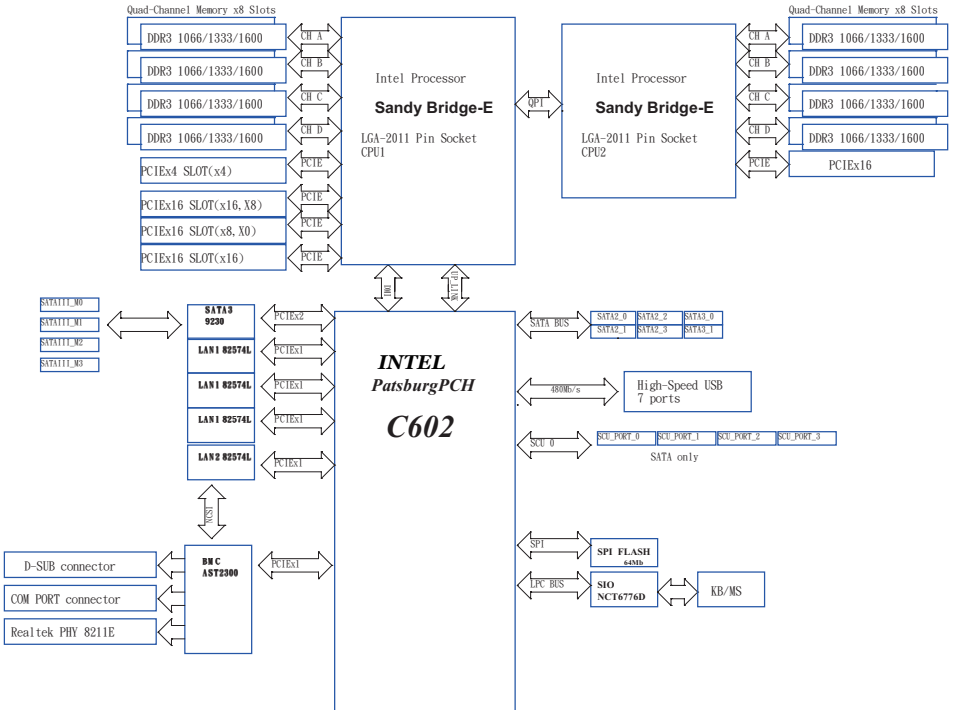



# EP2C602/D16

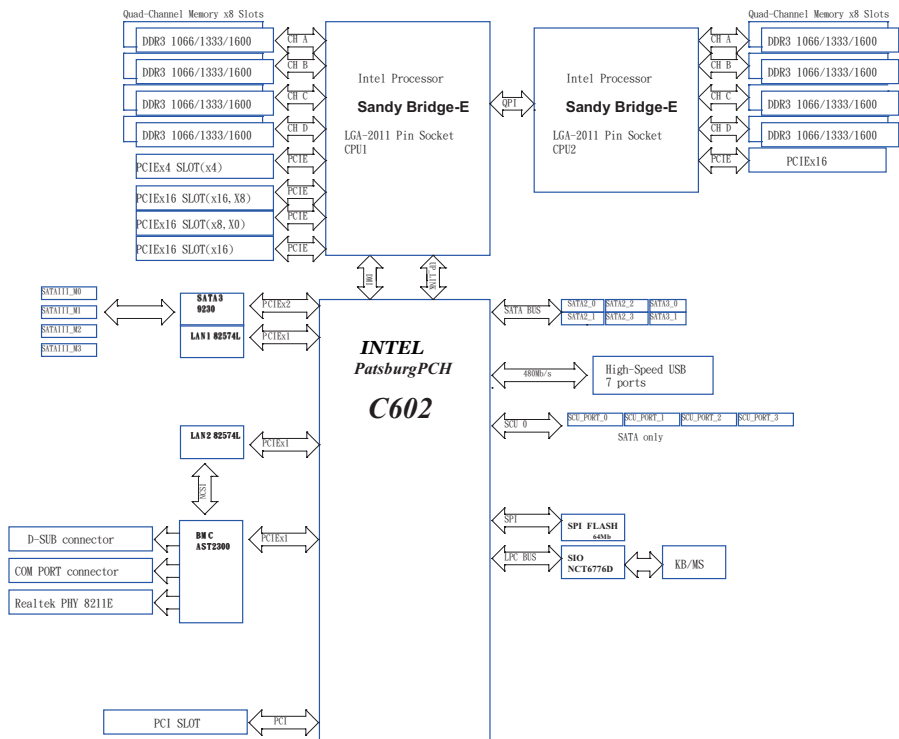

# EP2C606-4L

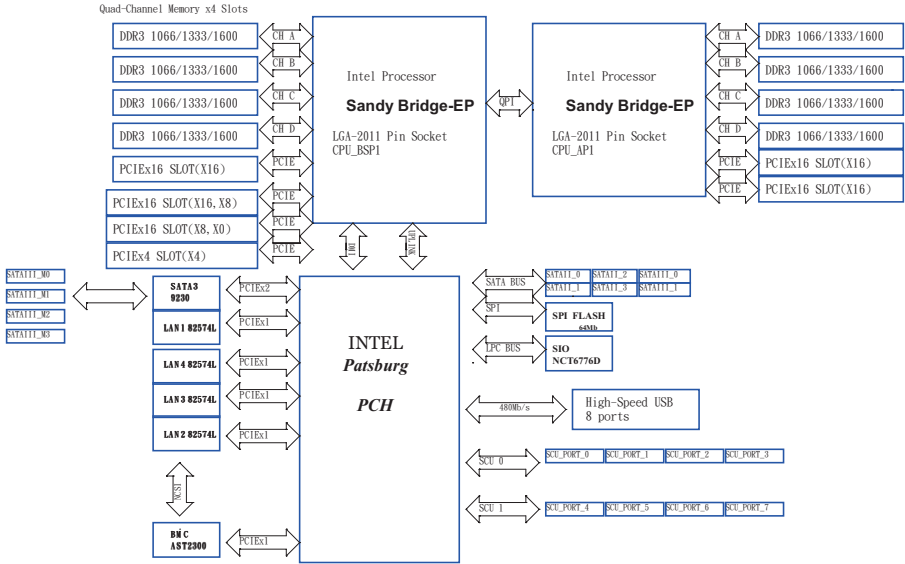

# EP2C602-4L

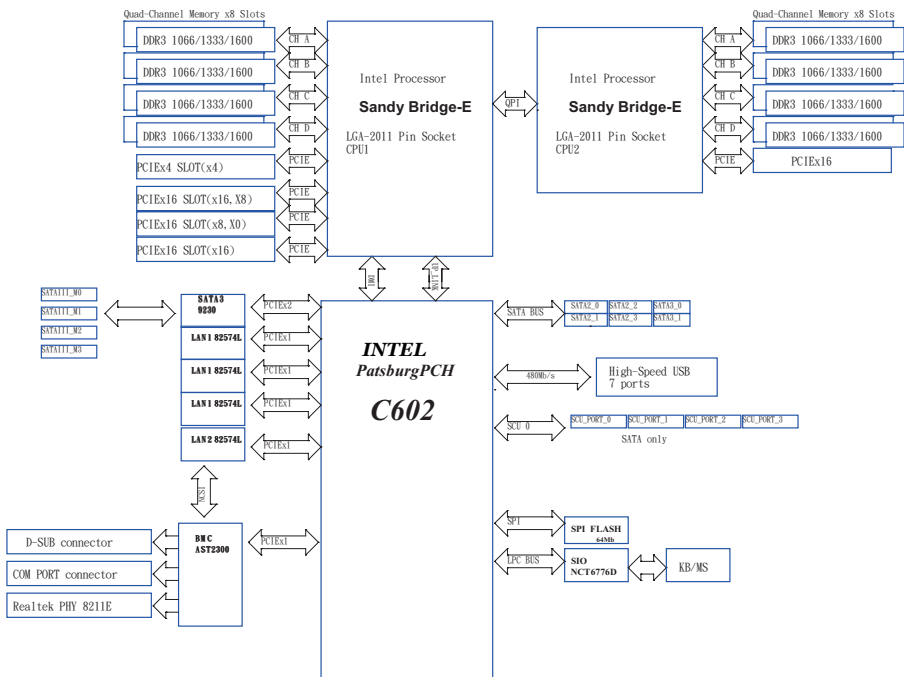

# EP2C602

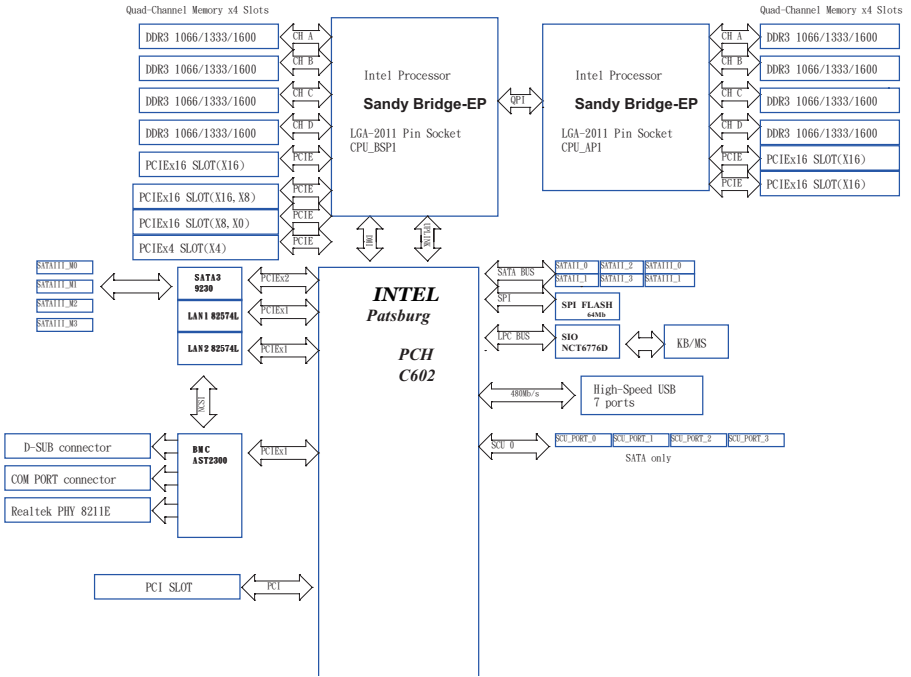

---

## Chapter 2: Installation

Before you install the motherboard, study the configuration of your chassis to ensure that the motherboard fits into it.

**EP2C606-4L/D16 / EP2C602-4L/D16 / EP2C602/D16 / EP2C606-4L / EP2C602-4L / EP2C602** are dual socket motherboards that support Intel® Xeon® E5-2400/1400 Series Processors. Please install a primary processor (BootStrap Processor) into “CPU\_BSP1” socket and then install a non-Primary Processor (Application Processors) into “CPU\_AP1” socket. \*For a single CPU, please install it into “CPU\_BSP1” socket (framed by a square).

### 2.1 Pre-installation Precautions

Take note of the following precautions before you install motherboard components or change any motherboard settings.

1. Make sure to unplug the power cord before installing or removing the motherboard. Failure to do so may cause physical injuries to you and damages to motherboard components.
2. In order to avoid damage from static electricity to the motherboard's components, NEVER place your motherboard directly on a carpet. Also remember to use a grounded wrist strap or touch a safety grounded object before you handle the components.
3. Hold components by the edges and do not touch the ICs.
4. Whenever you uninstall any components, place them on a grounded anti-static pad or in the bag that comes with the components.
5. When placing screws to secure the motherboard to the chassis, please do not over-tighten the screws! Doing so may damage the motherboard.

### 2.2 Screw Holes

Place screws into the holes indicated by circles to secure the motherboard to the chassis.

---

## 2.3 CPU Installation

For the installation of Intel 2011-Pin CPU, please follow the steps below.

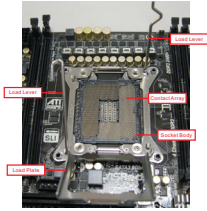

2011-Pin Socket Overview



Before you insert the 2011-Pin CPU into the socket, please check if the CPU surface is unclean or if there are any bent pins in the socket. Do not force to insert the CPU into the socket if above situation is found. Otherwise, the CPU will be seriously damaged.

### Step 1. Open the socket:

Step 1-1. Disengage the left lever by pressing it down and sliding it out of the hook.



Step 1-2. Disengage the right lever by pressing it down and sliding it out of the hook.



Step 1-3. Keep the right lever positioned at about 90 degrees in order to flip up the load plate.



### Step 2. Insert the 2011-Pin CPU:

Step 2-1. Hold the CPU by the edge with the triangle mark (Pin 1) on your upper right corner.



Step 2-2. Locate Pin1 and the two orientation key notches.

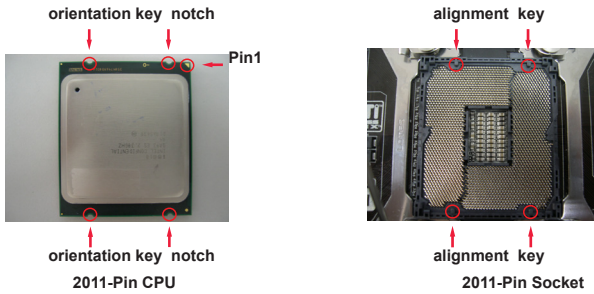

For proper inserting, please ensure to match the four orientation key notches of the CPU with the four alignment keys of the socket.

Step 2-3. Carefully place the CPU into the socket by using a purely vertical motion.

Step 2-4. Verify that the CPU is within the socket and properly mated to the orientation keys.



Step 3. Close the socket:

Step 3-1. Flip the load plate onto the IHS, then the cover will automatically come off by itself.



The cover must be placed if returning the motherboard for after service.

Step 3-2. Press down the right load lever, and secure it with the load plate tab under the retention tab.



Step 3-3. Press down the left load lever, and secure it with the load plate tab under the retention tab.



---

## 2.4 Installation of CPU Fan and Heatsink

This motherboard is equipped with 2011-Pin socket that supports Intel 2011-Pin CPU. Please adopt the type of heatsink and cooling fan compliant with Intel 2011-Pin CPU to dissipate heat. Before you installed the heatsink, you need to spray thermal interface material between the CPU and the heatsink to improve heat dissipation. Ensure that the CPU and the heatsink are securely fastened and in good contact with each other. Then connect the CPU fan to the CPU\_FAN connector.

**For proper installation, please kindly refer to the instruction manuals of your CPU fan and heatsink.**

Below is an example to illustrate the installation of the heatsink for 2011-Pin CPU.

- Step 1. Apply thermal interface material onto center of IHS on the socket surface.

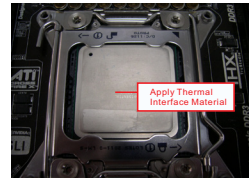

- Step 2. Place the heatsink onto the socket. Ensure fan cables are oriented on side closest to the CPU fan connector on the motherboard.

- Step 3. Align screws with the motherboard's holes.  
Step 4. Use a screw driver to install the screws.



If you don't fasten the screws, the heatsink cannot be secured on the motherboard.

- Step 5. Connect fan header with the CPU fan connector on the motherboard.  
Step 6. Secure excess cable with tie-wrap to ensure the cable does not interfere with fan operation or contact other components.



---

## 2.5 Installation of Memory Modules (DIMM)

This motherboard provides four 240-pin DDR3 (Double Data Rate 3) DIMM slots, and supports Dual Channel Memory Technology. For dual channel configuration, you always need to install two identical (the same brand, speed, size and chip-type) memory modules in the DDR3 DIMM slots to activate Dual Channel Memory Technology. Otherwise, it will operate at single channel mode.



1. It is not allowed to install a DDR or DDR2 memory module into a DDR3 slot; otherwise, this motherboard and DIMM may be damaged.
2. If you install only one memory module or two non identical memory modules, it is unable to activate Dual Channel Memory Technology.
3. Some DDR3 1GB double-sided DIMMs with 16 chips may not work on this motherboard. It is not recommended to install them on this motherboard.
4. A single memory module should be installed in the blue socket.
5. If you install only one CPU (CPU\_BSP1) on the motherboard, make sure to install DIMMs into DDR3\_A, DDR3\_B, DDR3\_C, or DDR3\_D slot(s).

### Installing a DIMM



Please make sure to disconnect the power supply before adding or removing DIMMs or system components.

- Step 1. Unlock a DIMM slot by pressing the retaining clips outward.
- Step 2. Align a DIMM on the slot such that the notch on the DIMM matches the break on the slot.

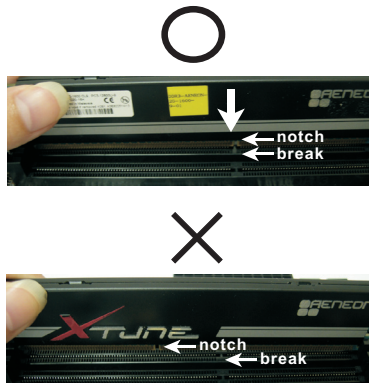

The DIMM only fits in one correct orientation. It will cause permanent damage to the motherboard and the DIMM if you force the DIMM into the slot at incorrect orientation.

- Step 3. Firmly insert the DIMM into the slot until the retaining clips at both ends fully snap back in place and the DIMM is properly seated.

---

## 2.6 Expansion Slots (PCI and PCI Express Slots)

### ***EP2C606-4L/D16 / EP2C602-4L/D16 / EP2C602/D16:***

There are 1 PCI slots and 5 PCI Express slots on the motherboard.

**PCI slot:** The PCI1 is used to install expansion cards that have 32-bit PCI interface.

#### **PCIe slots:**

PCIE6 (PCIE 3.0 x4 slot) is used for PCI Express x4 lane width cards.

PCIE3 (PCIE 3.0 x16 slot) is used for PCI Express x8 lane width graphics cards.

PCIE2, PCIE4, and PCIE5 (PCIE 3.0 x16 slot) are used for PCI Express x16 lane width graphics cards.



Please note that PCIE5 is available ONLY when the second CPU (CPU\_AP1) is installed.

### ***EP2C606-4L / EP2C602-4L / EP2C602:***

There are 1 PCI slot and 5 PCI Express slots on the motherboard.

**PCI slot:** The PCI1 slot is used to install expansion cards that have 32-bit PCI interface.

#### **PCIe slots:**

PCIE1 (PCIE 3.0 x4 slot) is used for PCI Express x4 lane width cards.

PCIE4, (PCIE 3.0 x16 slot) is used for PCI Express x8 lane width graphics cards.

PCIE3, PCIE5, PCIE6, and PCIE7 (PCIE 3.0 x16 slot) are used for PCI Express x16 lane width graphics cards.



Please note that PCIE6 & PCIE7 are available ONLY when the second CPU (CPU\_AP1) is installed.



**For EP2C606-4L/D16 / EP2C602-4L/D16 / EP2C602/D16:**

In single VGA card mode, it is recommended to install a PCI Express x16 graphics card on PCIE2 or PCIE4 slot.

**For EP2C606-4L / EP2C602-4L / EP2C602:**

In single VGA card mode, it is recommended to install a PCI Express x16 graphics card on PCIE3 or PCIE5 slot.

### **Installing an expansion card**

- Step 1. Before installing an expansion card, please make sure that the power supply is switched off or the power cord is unplugged. Please read the documentation of the expansion card and make necessary hardware settings for the card before you start the installation.
- Step 2. Remove the system unit cover (if your motherboard is already installed in a chassis).
- Step 3. Remove the bracket facing the slot that you intend to use. Keep the screws for later use.
- Step 4. Align the card connector with the slot and press firmly until the card is completely seated on the slot.
- Step 5. Fasten the card to the chassis with screws.
- Step 6. Replace the system cover.

## 2.7 Jumpers Setup

The illustration shows how jumpers are setup. When the jumper cap is placed on pins, the jumper is “Short”. If no jumper cap is placed on pins, the jumper is “Open”. The illustration shows a 3-pin jumper whose pin1 and pin2 are “Short” when jumper cap is placed on these 2 pins.

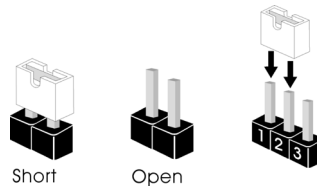

### ME Recovery Jumper

(3-pin ME\_RECOVERY1)  
(see p.12,16, 20, 24, 27, 30)

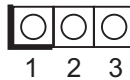

**1-2:**  
Default  
**2-3:**  
ME recovery mode

### PSU Jumper

**For EP2C606-4L/D16 /  
EP2C602-4L/D16 /  
EP2C602/D16:**

(9-pin PSU Jumper)  
(see p.12, 16, 20)



**1-2:**  
PSU\_SMBus loads the data  
via PCH chip  
**2-3:**  
PSU\_SMBus loads the data  
via BMC chip (Default)

**For EP2C606-4L /  
EP2C602-4L / EP2C602:**

(9-pin PSU Jumper)  
(see p. 24, 27, 30)



---

## 2.8 Onboard Headers and Connectors



Onboard headers and connectors are NOT jumpers. Do NOT place jumper caps over these headers and connectors. Placing jumper caps over the headers and connectors will cause permanent damage to the motherboard!

---

### Serial ATA2 Connectors (For EP2C60xD16 Series)

(SATAII\_2)  
(SATAII\_3)  
(SATAII\_4)  
(SATAII\_5)  
(see p.12, 16, 20)



These four Serial ATA2 (SATA2) connectors support SATA data cables for internal storage devices. The current SATA2 interface allows up to 3.0 Gb/s data transfer rate.

### (For EP2C60x Series)

(SATAII\_2\_3)  
(SATAII\_4\_5)  
(see p. 24, 27, 30)

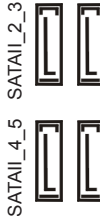

---

### Serial ATA3 Connectors (For EP2C60xD16 Series)

(SATAIII\_M0)  
(SATAIII\_M1)  
(SATAIII\_M2)  
(SATAIII\_M3)  
(SATAIII\_0)  
(SATAIII\_1)  
(see p.12, 16, 20)



These six Serial ATA3 (SATA3) connectors support SATA data cables for internal storage devices. The current SATA3 interface allows up to 6.0 Gb/s data transfer rate.

---

**(For EP2C60x Series)**

(SATAIII\_0\_1)  
(SATAIII\_M2\_M3)  
(SATAIII\_M0\_M1)  
(see p. 24, 27, 30)



---

**Serial ATA (SATA)  
Data Cable**



Either end of the SATA data cable can be connected to SATA / SATA2 / SATA3 hard disks or the SATA2 / SATA3 connectors on this motherboard.

---

**SCU Connectors**

**(For EP2C60xD16 Series)**

(SCU\_PORT\_0)  
(SCU\_PORT\_1)  
(SCU\_PORT\_2)  
(SCU\_PORT\_3)  
(see p.12, 16, 20)  
(SCU\_PORT\_4)  
(SCU\_PORT\_5)  
(SCU\_PORT\_6)  
(SCU\_PORT\_7)  
(see p.12)

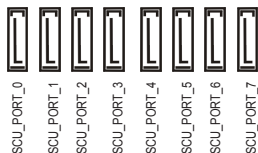

These eight SCU connectors support SAS/SATA data cables for internal storage devices. The current SAS2/ SATA3 interface allows up to 6.0 Gb/s data transfer rate. For connecting SAS HDDs, please contact SAS data cable dealers.

**SAS Connectors  
(For EP2C60x Series)**

- (SAS\_0)
- (SAS\_1)
- (SAS\_2)
- (SAS\_3)
- (see p. 24, 27, 30)
- (SAS\_4)
- (SAS\_5)
- (SAS\_6)
- (SAS\_7)
- (see p.24, 27)

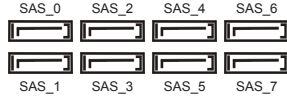

These eight SAS connectors support SAS/SATA data cables for internal storage devices. The current SAS2/ SATA3 interface allows up to 6.0 Gb/s data transfer rate. For connecting SAS HDDs, please contact SAS data cable dealers.

**USB 2.0 Headers  
and Ports**

- (9-pin USB\_2\_3)
- (9-pin USB\_4\_5)
- (see p.12,16, 20, 24, 27, 30)

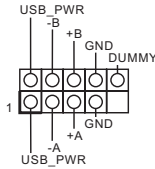

Besides two default USB 2.0 ports on the I/O panel, there are two USB 2.0 headers and one port on this motherboard. Each USB 2.0 header can support two USB 2.0 ports.

- (USB\_6)
- (see p.12,16, 20, 24, 27, 30)



**TPM Header**

- (17-pin TPM1)
- (see p.12,16, 20, 24, 27, 30)

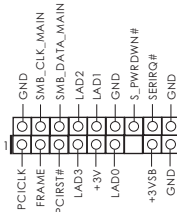

This connector supports Trusted Platform Module (TPM) system, which can securely store keys, digital certificates, passwords, and data. A TPM system also helps enhance network security, protects digital identities, and ensures platform integrity.





**Auxiliary Panel Header**  
 (18-pin AUX\_PANEL1)  
 (see p.12,16, 20, 24, 27, 30)

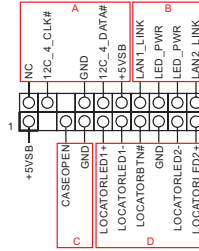

This header supports multiple functions on the front panel, including front panel SMB, internet status indicator and chassis intrusion pin.



**A. Front panel SMBus connecting pin (6-pin FPSMB)**

This header allows you to connect SMBus (System Management Bus) equipment. It can be used for communication between peripheral equipment in the system, which has slower transmission rates, and power management equipment.

**B. Internet status indicator (2-pin LAN1\_LED, LAN2\_LED)**

These two 2-pin headers allow you to use the Gigabit internet indicator cable to connect to the LAN status indicator. When this indicator flickers, it means that the internet is properly connected.

**C. Chassis intrusion pin (2-pin CHASSIS)**

This header is provided for host computer chassis with chassis intrusion detection designs. In addition, it must also work with external detection equipment, such as a chassis intrusion detection sensor or a microswitch. When this function is activated, if any chassis component movement occurs, the sensor will immediately detect it and send a signal to this header, and the system will then record this chassis intrusion event. The default setting is set to the CASEOPEN and GND pin; this function is off.

**D. Locator LED (6-pin LOCATOR)**

This header is for the locator switch and LED on the front panel.

**Speaker Header**  
 (4-pin SPEAKER1)  
 (see p.12,16, 20, 24, 27, 30)

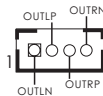

Please connect the speaker to this header.

## Front and Rear Fan Connectors

(4-pin FRNT\_FAN1)

(4-pin FRNT\_FAN2)

(4-pin FRNT\_FAN3)

(4-pin FRNT\_FAN4)

(see p.12,16, 20, 24, 27, 30)

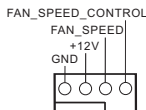

Please connect the fan cables to the fan connectors and match the black wire to the ground pin. All fans supports Fan Control.

(4-pin REAR\_FAN1)

(4-pin REAR\_FAN2)

(see p.12,16, 20, 24, 27, 30)

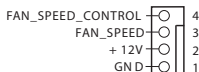

## CPU Fan Connectors

### (For EP2C60xD16 Series)

(4-pin CPU\_FAN1\_1)

(see p.12, 16, 20)



Please connect the CPU fan cable to the connector and match the black wire to the ground pin.

(4-pin CPU\_FAN2\_1)

(see p.12, 16, 20)

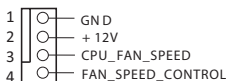

### (For EP2C60x Series)

(4-pin CPU\_FAN1\_1)

(see p. 24, 27, 30)

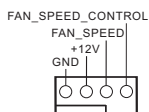

(4-pin CPU\_FAN2\_1)

(see p. 24, 27, 30)





Though this motherboard provides a 4-Pin CPU fan (Quiet Fan) connector, 3-Pin CPU fans can still work successfully even without the fan speed control function. If you plan to connect a 3-Pin CPU fan to the CPU fan connector on this motherboard, please connect it to Pin 1-3.

**Pin 1-3 Connected** ←

3-Pin Fan Installation



### (For EP2C60xD16 Series)

(3-pin CPU\_FAN1\_2)

(see p.12, 16, 20)

(3-pin CPU\_FAN2\_2)

(see p.12, 16, 20)

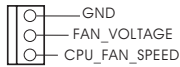

### (For EP2C60x Series)

(3-pin CPU\_FAN1\_2)

(see p. 24, 27, 30)



(3-pin CPU\_FAN2\_2)

(see p. 24, 27, 30)

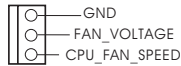

### ATX Power Connector

#### (For EP2C60xD16 Series)

(24-pin ATXPWR1)

(see p.12, 16, 20)

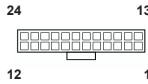

Please connect an ATX power supply to this connector.

#### (For EP2C60x Series)

(24-pin ATXPWR1)

(see p. 24, 27, 30)

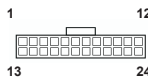



Though this motherboard provides a 24-pin ATX power connector, it can still work if you adopt a traditional 20-pin ATX power supply. To use a 20-pin ATX power supply, please plug your power supply along Pin 1 and Pin 13.

20-Pin ATX Power Supply Installation

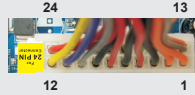

Though this motherboard provides an 8-pin ATX 12V power connector, it can still work if you adopt a traditional 4-pin ATX 12V power supply. To use a 4-pin ATX power supply, please plug your power supply along Pin 1 and Pin 5.

4-Pin ATX 12V Power Supply Installation



## ATX 12V Power Connector

### (For EP2C60xD16 Series)

(8-pin ATX12V1)  
(see p.12, 16, 20)

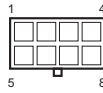

(8-pin ATX12V2)  
(see p.12, 16, 20)

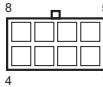

### (For EP2C60x Series)

(8-pin ATX12V1)  
(see p. 24, 27, 30)  
(8-pin ATX12V\_1)  
(see p. 24, 27, 30)

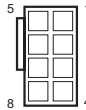

Please connect an ATX 12V power supply to this connector.

---

### Serial port Header

(9-pin COM2)

(see p.12,16, 20, 24, 27, 30)

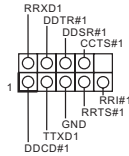

This COM2 header supports a serial port module.

---

### Intelligent Platform Management Bus header

(4-pin IPMB\_1)

(see p.12,16, 20, 24, 27, 30)

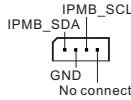

This 4-pin connector is used to provide a cabled base-board or front panel connection for value added features and 3rd-party add-in cards, such as Emergency Management cards, that provide management features using the IPMB.

---

### Thermal Sensor header

(3-pin TR1)

(see p.12,16, 20, 24, 27, 30)



Please connect the thermal sensor cable to either pin 1-2 or pin 2-3 and the other end to the device which you wish to monitor its temperature.

---

### Clear CMOS Pad

(CLR CMOS2)

(see p.12,16, 20, 24, 27, 30)



CLR CMOS2 allows you to clear the data in CMOS. To clear CMOS, take out the CMOS battery and short the Clear CMOS Pad.

Serial General Purpose  
Input/Output Header  
**(For EP2C60xD16 Series)**

(SCU\_SGPIO1)  
(SCU\_SGPIO2)  
(see p.12, 16, 20)

**(For EP2C60x Series)**

(SAS\_SGPIO1)  
(SAS\_SGPIO2)  
(see p. 24, 27, 30)

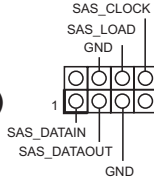

This header supports Serial Link interface for onboard SAS / SATA connections.

(SATA\_SGPIO1)  
(SATA\_SGPIO2)  
(see p.12,16, 20, 24, 27, 30)

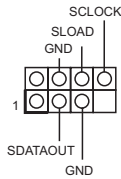

This header supports Serial Link interface for onboard SATA connections.

PSU SMBus

(PSU\_SMB1)  
(see p.12,16, 20, 24, 27, 30)

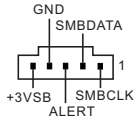

PSU SMBus monitors the status of the power supply, fan and system temperature.

Non Maskable Interrupt  
Button Header

(NMI\_BTN1)  
(see p.12,16, 20, 24, 27, 30)



Please connect a NMI device to this header.

Front Lan LED  
Connector

(FRONT\_LED\_LAN34)  
(see p.12, 16, 24, 27)

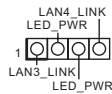

This 4-pin connector is used for the front LAN status indicator.

---

## **2.9 Driver Installation Guide**

To install the drivers to your system, please insert the support CD to your optical drive first. Then, the drivers compatible to your system can be auto-detected and listed on the support CD driver page. Please follow the order from top to bottom to install those required drivers. Therefore, the drivers you install can work properly.



---

## 2.10 Hot Plug for Hard Disk Drives

This motherboard supports Hot Plug for HDDs in AHCI / RAID mode.



### **What is Hot Plug?**

If the HDDs are NOT set for RAID, it is called “Hot Plug” for the action to insert and remove the HDDs while the system is still powered on and in working condition. However, please note that it cannot perform Hot Plug if the OS has been installed into the HDD.

---

## Chapter 3: UEFI SETUP UTILITY

### 3.1 Introduction

This section explains how to use the UEFI SETUP UTILITY to configure your system. The UEFI chip on the motherboard stores the UEFI SETUP UTILITY. You may run the UEFI SETUP UTILITY when you start up the computer. Please press <F2> or <Del> during the Power-On-Self-Test (POST) to enter the UEFI SETUP UTILITY, otherwise, POST will continue with its test routines.

If you wish to enter the UEFI SETUP UTILITY after POST, restart the system by pressing <Ctl> + <Alt> + <Delete>, or by pressing the reset button on the system chassis. You may also restart by turning the system off and then back on.



Because the UEFI software is constantly being updated, the following UEFI setup screens and descriptions are for reference purpose only, and they may not exactly match what you see on your screen.

#### 3.1.1 UEFI Menu Bar

The top of the screen has a menu bar with the following selections:

- Main** For setting system time/date information
- Advanced** For advanced system configurations
- H/W Monitor** Displays current hardware status
- Boot** For configuring boot settings and boot priority
- Security** For security settings
- Save & Exit** Exit the current screen or the UEFI Setup Utility
- Server Mgmt** For managing the server
- Event Logs** For event log configuration

---

### 3.1.2 Navigation Keys

Use < ← > key or < → > key to choose among the selections on the menu bar, and use < ↑ > key or < ↓ > key to move the cursor up or down to select items, then press <Enter> to get into the sub screen. You can also use the mouse to click your required item.

Please check the following table for the descriptions of each navigation key.

Navigation Key(s)	Function Description
+ / -	To change option for the selected items
<Tab>	Switch to next function
<PGUP>	Go to the previous page
<PGDN>	Go to the next page
<HOME>	Go to the top of the screen
<END>	Go to the bottom of the screen
<F1>	To display the General Help Screen
<F7>	Discard changes and exit the SETUP UTILITY
<F9>	Load optimal default values for all the settings
<F10>	Save changes and exit the SETUP UTILITY
<F12>	Print screen
<ESC>	Jump to the Exit Screen or exit the current screen

---

## 3.2 Main Screen

When you enter the UEFI SETUP UTILITY, the Main screen will appear and display the system overview.

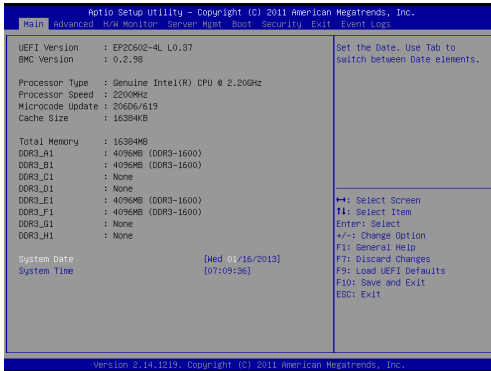

---

### 3.3 Advanced Screen

In this section, you may set the configurations for the following items: ACPI Configuration, WHEA Configuration, CPU Configuration, North Bridge Configuration, South Bridge Configuration, USB Configuration, ME Subsystem, Clock Generator Configuration, Storage Configuration, Super IO Configuration, Serial Port Console Redirection and Voltage Control.

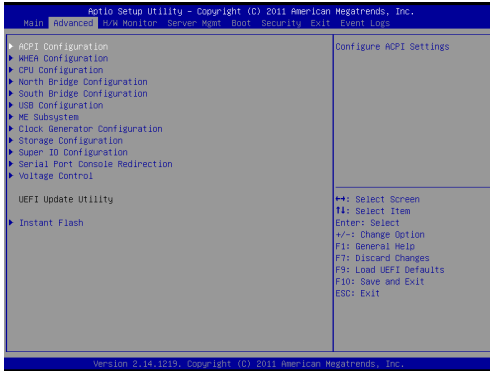

Setting wrong values in this section may cause the system to malfunction.

#### Instant Flash

Instant Flash is a UEFI flash utility embedded in Flash ROM. This convenient UEFI update tool allows you to update system UEFI without entering operating systems first like MS-DOS or Windows®. Just save the new UEFI file to your USB flash drive, floppy disk or hard drive and launch this tool, then you can update your UEFI only in a few clicks without preparing an additional floppy diskette or other complicated flash utility. Please be noted that the USB flash drive or hard drive must use FAT32/16/12 file system. If you execute Instant Flash utility, the utility will show the UEFI files and their respective information. Select the proper UEFI file to update your UEFI, and reboot your system after the UEFI update process is completed.

---

### 3.3.1 ACPI Configuration



#### Suspend Mode

Use this item to enable or disable the highest ACPI Sleep state (S1). If enabled, the system enters S1 level when the SUSPEND button is pressed.

#### ACPI HPET Table

Use this item to enable or disable ACPI HPET Table. The default value is [Enabled].

#### PS/2 Keyboard Power On

Use this item to enable or disable PS/2 keyboard to turn on the system from the power-soft-off mode.

#### PCI Devices Power On

Use this item to enable or disable PCI devices to turn on the system from the power-soft-off mode.

#### Ring-In Power On

Use this item to enable or disable Ring-In signals to turn on the system from the power-soft-off mode.

#### RTC Alarm Power On

Use this item to enable or disable RTC (Real Time Clock) to power on the system.

#### USB Keyboard/Remote Power On

Use this item to enable or disable USB Keyboard/Remote to turn on the system from the power-soft-off mode.

---

**USB Mouse Power On**

Use this item to enable or disable USB Mouse to turn on the system from the power-soft-off mode.

---

### 3.3.2 WHEA Configuration

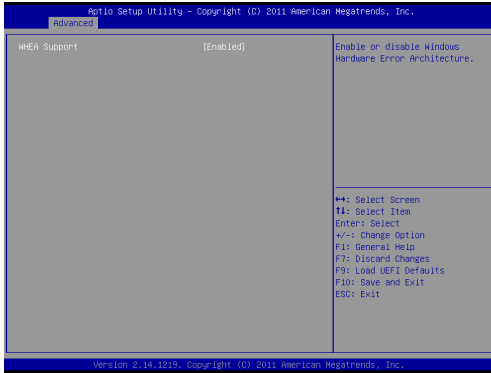

#### WHEA Support

Use this option to enable or disable Windows Hardware Error Architecture. The default value is [Enabled].



---

### 3.3.3 CPU Configuration

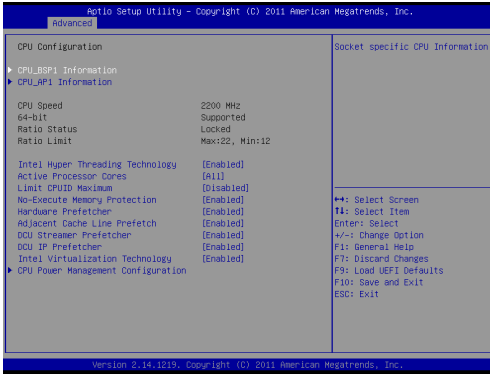

#### **CPU\_BSP1 Information**

Display information regarding the primary processor (Boot Strap Processor).

#### **CPU\_AP1 Information**

Display information regarding the non-primary processor (Application Processors).

#### **Intel Hyper Threading Technology**

To enable this feature, a computer system with an Intel processor that supports Hyper-Threading technology and an operating system that includes optimization for this technology is required. This option will be hidden if the installed CPU does not support Hyper-Threading technology.

#### **Active Processor Cores**

Use this item to select the number of cores to enable in each processor package. The default value is [All].

#### **Limit CPUID Maximum**

This function allows you to limit CPUID maximum value. Unless the OS is Windows<sup>®</sup> NT, disable this function.

---

### **No-Execute Memory Protection**

No-Execution (NX) Memory Protection Technology is an enhancement to the IA-32 Intel Architecture. An IA-32 processor with “No Execute (NX) Memory Protection” can prevent data pages from being used by malicious software to execute codes. This option will be hidden if the current CPU does not support No-Execute Memory Protection.

### **Hardware Prefetcher**

Use this to turn on/off the MLC streamer prefetcher.

### **Adjacent Cache Line Prefetch**

Use this to turn on/off prefetching of adjacent cache lines.

### **DCU Streamer Prefetcher**

If enabled, the DCU (data cache unit) Streamer Prefetcher prefetches the next L1 Data line based upon multiple loads in same cache line. It is recommended to enable this option to enhance data processing capacity.

### **DCU IP Prefetcher**

If enabled, the DCU (data cache unit) IP (Instruction Pointer) Prefetcher predicts what memory addresses are going to be used by the program and deliver that data just in time.

### **Intel Virtualization Technology**

When this option is set to [Enabled], a VMM (Virtual Machine Architecture) can utilize the additional hardware capabilities provided by Vanderpool Technology. This option will be hidden if the installed CPU does not support Intel Virtualization Technology.

### **CPU Power Management**

Use this to configure CPU Power Management.

---

### 3.3.4 North Bridge Configuration

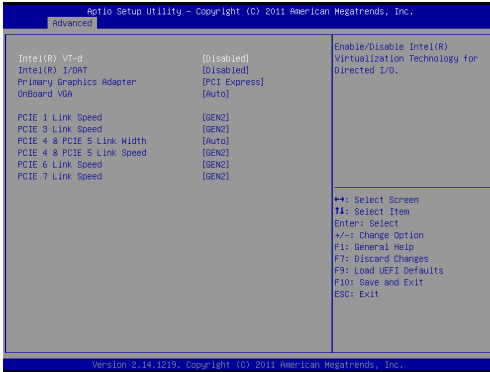

#### IOH ( I/O hub) Configuration

##### Intel® VT-d

Use this to enable/disable Intel® Virtualization Technology for the Directed I/O.

##### Intel® I/OAT

Use this to enable/disable Intel® I/O Acceleration Technology.

##### Primary Graphics Adapter

This allows you to select a graphics device as the primary display. The default value is [PCI Express].

##### Onboard VGA

Enable or disable the onboard VGA.

#### ***For EP2C606-4L/D16 / EP2C602-4L/D16 / EP2C602/D16:***

##### PCIe2 Link Speed

This allows you to select PCIe2 Link Speed.

##### PCIe3 & PCIe4 Link Width

This allows you to select PCIe 3 & PCIe 4 Link Width.

##### PCIe3 & PCIe4 Link Speed

This allows you to select PCIe 3 & PCIe 4 Link Speed.

##### PCIe5 Link Speed

This allows you to select PCIe5 Link Speed.

##### PCIe6 Link Speed

This allows you to select PCIe6 Link Speed.

---

***For EP2C606-4L / EP2C602-4L / EP2C602:***

**PCIE1 Link Speed**

This allows you to select PCIE1 Link Speed.

**PCIE3 Link Speed**

This allows you to select PCIE3 Link Speed.

**PCIE4 & PCIE5 Link Width**

This allows you to select PCIE 4 & PCIE 5 Link Width.

**PCIE4 & PCIE5 Link Speed**

This allows you to select PCIE 4 & PCIE 5 Link Speed.

**PCIE6 Link Speed**

This allows you to select PCIE6 Link Speed.

**PCIE7 Link Speed**

This allows you to select PCIE7 Link Speed.

---

## **QPI ( Intel Quickpath Interconnect) Configuration**

### **Isoc**

Use this to enable/disable Isoc. It is recommended to select [Enabled].

### **QPI Link Speed Mode**

This allows you to select QPI Link Speed Mode. It is recommended to select [Auto].

### **QPI Link Frequency Select**

This allows you to select QPI Link Frequency.

## **Memory Configuration**

### **Memory Mode**

Select the mode for memory initialization.

[Independent]:

Independent channel mode.

[Mirroring]:

The memory subsystem writes identical data to two channels simultaneously. Identical memory modules should be installed in the two channels closest to the processor.

[Lock Step]:

The two channels closest to the processor are combined to form a single channel. Memory modules must be identical in size, speed, and technology in corresponding slots.

[Sparing]:

This mode occurs when on-demand inactive memory is automatically activated by the system to temporarily replace failed memory until a service action can be performed.

### **DRAM RAPL BWLIMIT**

This item sets the limits on the average power consumption and the bandwidth of a DRAM module. The options are Disabled, 0, 1 (Intel recommended value), 8 and 16.

### **Perform and DFX devices**

This item can set the Perfmon and DFX devices hidden or unhidden.

### **DRAM RAPL (Running Average Power Limit ) Mode**

RAPL (Running Average Power Limit ) provides mechanisms to enforce power consumption limits on supported processors. The default is [DRAM RAPL Mode 1].

---

## **Numa**

Enable or disable the support of Non-Uniform Memory Access.

## **MPST Support**

Enable or disable the support of Memory Power State Table.

## **DRAM Frequency**

If [Auto] is selected, the motherboard will detect the memory module(s) inserted and assign the appropriate frequency automatically.

## **Channel Interleaving**

It allows you to enable Channel Memory Interleaving. The default value is [Auto].

## **Rank Interleaving**

It allows you to select a rank memory interleaving method. The default value is [Auto].

## **Patrol Scrub**

Patrol Scrub is a background activity initiated by the processor to seek out and fix memory errors. The default value is [Enabled].

## **Demand Scrub**

Fix the error when the CPU or I/O issues a demand-read command, and the read data from memory turns out to be a correctable error. The default value is [Disabled].

## **Data Scrambling**

Enable this feature to ensure data security and integrity.

## **Device Tagging**

The ability to replace a device with excessive corrected error. Once a device is tagged, errors can only be detected and not corrected.

## **Thermal Throttling**

Use this automatic memory throttling feature to reduce power consumption. The default value is [CLTT] (Closed Loop Thermal Throttling).

## **DIMM Information**

Display DIMM information.

---

### 3.3.5 South Bridge Configuration

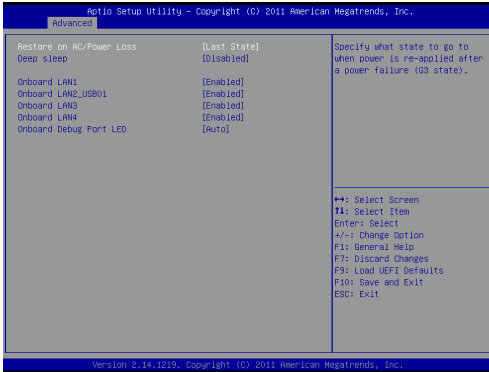

#### Restore on AC/Power Loss

This allows you to set the power state after an unexpected AC/power loss. If [Power Off] is selected, the AC/power remains off when the power recovers. If [Power On] is selected, the AC/power resumes and the system starts to boot up when the power recovers.

#### Deep Sleep

Mobile platforms support Deep S4/S5 in DC only and desktop platforms support Deep S4/S5 in AC only. The default value is [Disabled].

#### Onboard LAN1

This allows you to enable or disable the Onboard LAN1.

#### Onboard LAN2\_USB01

This allows you to enable or disable the Onboard LAN2\_USB01.

#### Onboard LAN3 (For EP2C606-4L/D16 / EP2C602-4L/D16 / EP2C606-4L / EP2C602-4L Only)

This allows you to enable or disable the Onboard LAN3.

#### Onboard LAN4 (For EP2C606-4L/D16 / EP2C602-4L/D16 / EP2C606-4L / EP2C602-4L Only)

This allows you to enable or disable the Onboard LAN4.

#### Onboard Debug Port LED

Use this to enable or disable the Onboard Debug Port LED. The default value is [Auto].

---

### 3.3.6 USB Configuration

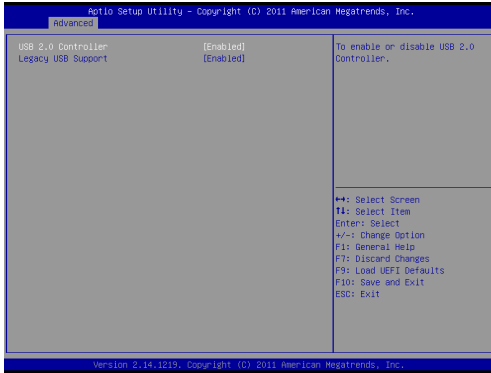

#### USB 2.0 Controller

Use this item to enable or disable the use of USB 2.0 controller.

#### Legacy USB Support

Use this option to select legacy support for USB devices. There are four configuration options: [Enabled], [Auto], [Disabled] and [UEFI Setup Only]. The default value is [Enabled]. Please refer to below descriptions for the details of these four options:

[Enabled] - Enables support for legacy USB.

[Auto] - Enables legacy support if USB devices are connected.

[Disabled] - USB devices are not allowed to use under legacy OS and UEFI setup when [Disabled] is selected. If you have USB compatibility issues, it is recommended to select [Disabled] to enter OS.

[UEFI Setup Only] - USB devices are allowed to use only under UEFI setup and Windows / Linux OS.



---

### 3.3.7 Intel® ME Subsystem

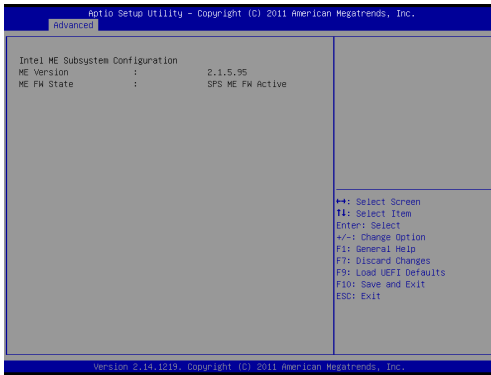

### Intel® ME Subsystem

Display information regarding Intel® Management Engine.

---

### 3.3.8 Clock Generator Configuration

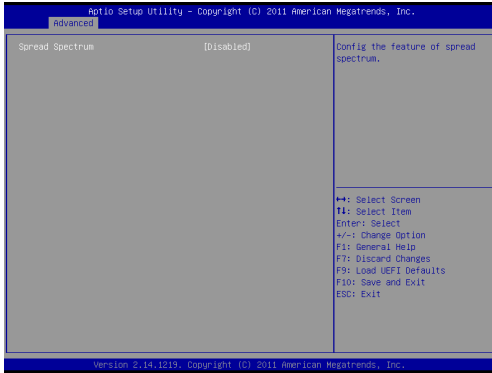

#### Spread Spectrum

It is recommended to disable this option for better system stability.

---

### 3.3.9 Storage Configuration

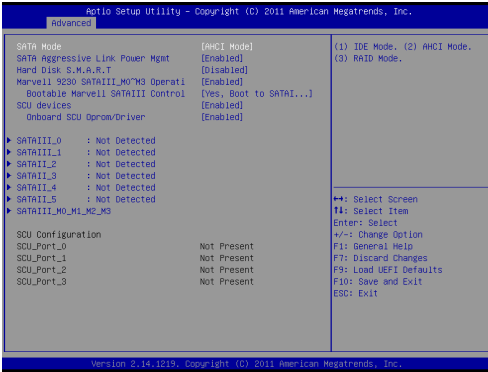

#### SATA Mode Selection

This item is for SATAIII\_0\_1, SATAII\_2\_3 and SATAII\_4\_5 ports. Use this to select SATA mode. Configuration options: [IDE Mode], [AHCI Mode], [RAID Mode] and [Disabled]. The default value is [AHCI Mode].



AHCI (Advanced Host Controller Interface) supports NCQ and other new features that will improve SATA disk performance but IDE mode does not have these advantages.

#### SATA Aggressive Link Power Management

Use this item to configure Aggressive Link Power Management.

#### Hard Disk S.M.A.R.T.

Use this to enable or disable S.M.A.R.T. (Self-Monitoring, Analysis, and Reporting Technology).

#### Marvell 9230 SATA3\_M0~M3 Operation:

This item is for SATAIII\_M0\_M1 and SATAIII\_M2\_M3 ports. Use this to enable or disable Marvell SATA3 operation mode.

#### Bootable Marvell SATA3 Controller

Use this to select onboard Marvell SATAIII Option ROM

#### SCU Devices

Use this to enable or disable SCU devices.

---

### **Onboard SCU Oprom/Driver**

Use this to enable or disable Onboard Marvell SATA3 Option ROM. If Option ROM is disabled, you cannot use the SATA devices connected to the Marvell SATA3 controller as Boot Device.



We recommend to use Intel® C606/C602 SATA ports (SATAIII\_0\_1, SATAII\_2\_3 and SATAII\_4\_5) for your bootable devices. This will minimum your boot time and get the best performance. But if you still want to boot from the Marvell SATA3 controller, you can enable it from the UEFI.

---

### 3.3.10 Super IO Configuration

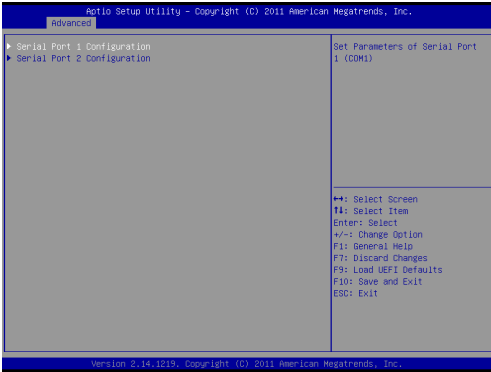

#### Serial Port 1 Configuration

Use this item to configure the onboard serial port 1.

#### Serial Port 2 Configuration

Use this item to configure the onboard serial port 2.

---

### 3.3.11 Serial Port Console Redirection

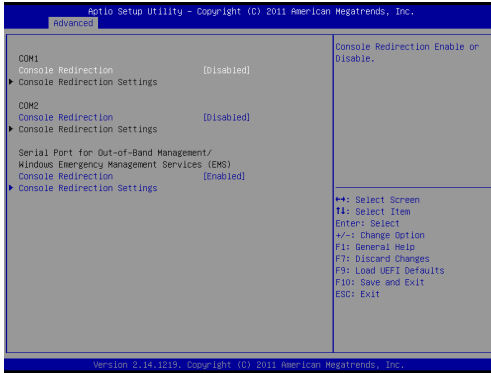

#### Console Redirection

Use this option to enable or disable Console Redirection.

#### Console Redirection Settings

Use this option to configure Console Redirection Settings.

---

### 3.3.12 Voltage Control

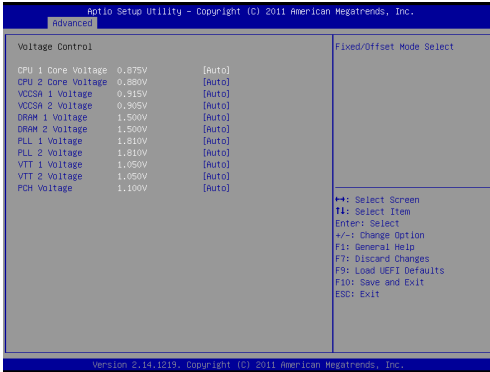

#### **CPU 1 Core voltage**

Use this to select CPU 1 Core voltage. The default value is [Auto].

#### **CPU 2 Core voltage**

Use this to select CPU 2 Core voltage. The default value is [Auto].

#### **VCCSA 1 Voltage**

Use this to select VCCSA 1 Voltage. The default value is [Auto].

#### **VCCSA 2 Voltage**

Use this to select VCCSA 2 Voltage. The default value is [Auto].

#### **DRAM 1 Voltage**

Use this to select DRAM 1 Voltage. The default value is [Auto].

#### **DRAM 2 Voltage**

Use this to select DRAM 2 Voltage. The default value is [Auto].

#### **PLL 1 Voltage**

Use this to select CPU PLL 1 Voltage. The default value is [Auto].

#### **PLL 2 Voltage**

Use this to select CPU PLL 2 Voltage. The default value is [Auto].

#### **VTT 1 Voltage**

Use this to select VTT 1 Voltage. The default value is [Auto].

#### **VTT 2 Voltage**

Use this to select VTT 2 Voltage. The default value is [Auto].

#### **PCH Voltage**

Use this to select PCH Voltage. The default value is [Auto].

---

### 3.4 Hardware Health Event Monitoring Screen

In this section, it allows you to monitor the status of the hardware on your system, including the parameters of the CPU temperature, motherboard temperature and the critical voltage.

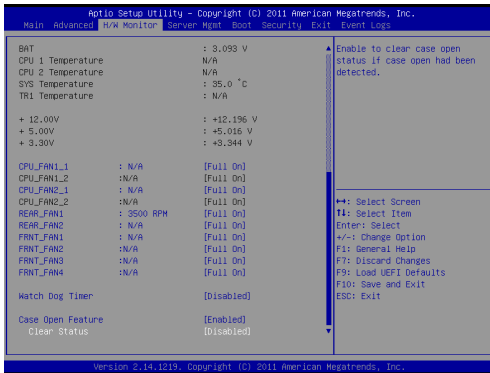

#### CPU\_Fan1\_1 Setting

This allows you to set the speed of CPU\_Fan1\_1. The default value is [Full On].

#### CPU\_Fan1\_2 Setting

This allows you to set the speed of CPU\_Fan1\_2. The default value is [Full On].

#### CPU\_Fan2\_1 Setting

This allows you to set the speed of CPU\_Fan2\_1. The default value is [Full On].

#### CPU\_Fan2\_2 Setting

This allows you to set the speed of CPU\_Fan2\_2. The default value is [Full On].

#### REAR\_Fan1 Setting

This allows you to set the speed of REAR Fan1. The default value is [Full On].

#### REAR\_Fan2 Setting

This allows you to set the speed of REAR Fan1. The default value is [Full On].

#### FRNT\_Fan1 Setting

This allows you to set the speed of FRNT Fan1. The default value is [Full On].



---

**FRNT Fan2 Setting**

This allows you to set the speed of FRNT Fan2. The default value is [Full On].

**FRNT Fan3 Setting**

This allows you to set the speed of FRNT Fan3. The default value is [Full On].

**FRNT Fan4 Setting**

This allows you to set the speed of FRNT Fan4. The default value is [Full On].

**Watch Dog Timer**

This allows you to enable or disable the Watch Dog Timer. The default value is [Disabled].

**Case Open Feature**

This allows you to enable or disable the Case Open Feature. The default value is [Enabled].

**Clear Status**

Enable to clear case open status if case open has been detected.

---

## 3.5 Server Management

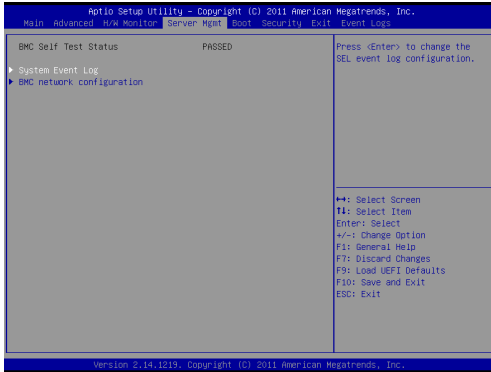

### System Event Log

Enter to configure System Event Logging features during boot.

### BMC Network Configuration

Enter to configure BMC Network parameters.

### Configuration Address Source

Select to configure BMC network parameters statically or dynamically (by BIOS or BMC).

Configuration options: [Unspecified], [Static], and [Dynamic].

Unspecified: BMC network parameters are configured by BMC itself.

Static: Manually enter the IP Address, Subnet Mask and Gateway Address in the BIOS for BMC LAN channel configuration.

Dynamic: IP address, Subnet Mask and Gateway Address are automatically assigned by the network's DHCP server.

To configure BMC network parameters using the BIOS setup, select either [Static] or [Dynamic] option.

To configure BMC network parameters using the BMC web interface, select [Unspecified] option.

---

## 3.6 Boot Screen

In this section, it will display the available devices on your system for you to configure the boot settings and the boot priority.

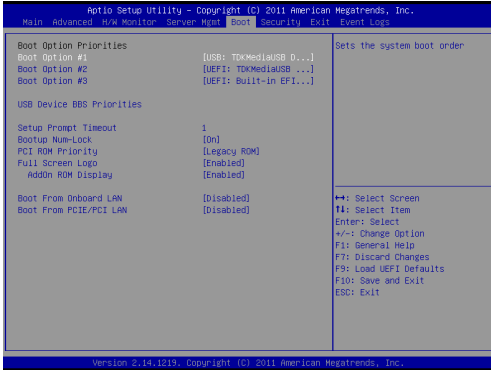

### Boot Option #1

Select boot option #1.

### Boot Option #2

Select boot option #2.

### Boot Option #3

Select boot option #3.

### Hard Drive BBS Priorities

Set the boot priorities for hard drives.

### CD/DVD ROM Drive BBS Priorities

Set the boot priorities for CD/DVD ROM Drive.

### USB Device BBS Priorities

Set the boot priorities for USB devices.

### Setup Prompt Timeout

This shows the number of seconds to wait for setup activation key. 65535(0XFFFF) means indefinite waiting.

### Bootup NumLock State

If this item is set to [On], it will automatically activate the Numeric Lock function after boot-up.

---

### **PCI ROM Priority**

Use this to adjust the PCI ROM Priority. The default value is [Legacy ROM].

### **Full Screen Logo**

Use this item to enable or disable OEM Logo. The default value is [Enabled].

### **AddOn ROM Display**

Use this option to adjust AddOn ROM Display. If you enable the option “Full Screen Logo” but you want to see the AddOn ROM information when the system boots, please select [Enabled]. Configuration options: [Enabled] and [Disabled]. The default value is [Enabled].

### **Boot From Onboard LAN**

Use this item to enable or disable the Boot From Onboard LAN feature.

### **Boot From PCIE/PCI LAN**

Use this item to enable or disable the Boot From PCIE/PCI LAN feature.

---

### 3.7 Security Screen

In this section, you may set or change the supervisor/user password for the system. For the user password, you may also clear it.

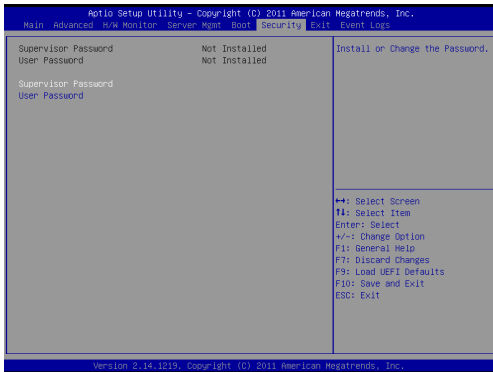

---

## 3.8 Exit Screen



### Save Changes and Exit

When you select this option, the following message “Save configuration changes and exit setup?” will pop-out. Select [Yes] to save the changes and exit the UEFI SETUP UTILITY.

### Discard Changes and Exit

When you select this option, the following message “Discard changes and exit setup?” will pop-out. Select [Yes] to exit the UEFI SETUP UTILITY without saving any changes.

### Discard Changes

When you select this option, the following message “Discard changes?” will pop-out. Select [Yes] to discard all changes.

### Load UEFI Defaults

Load UEFI default values for all the setup questions. F9 key can be used for this operation.

---

## 3.9 Event Logs

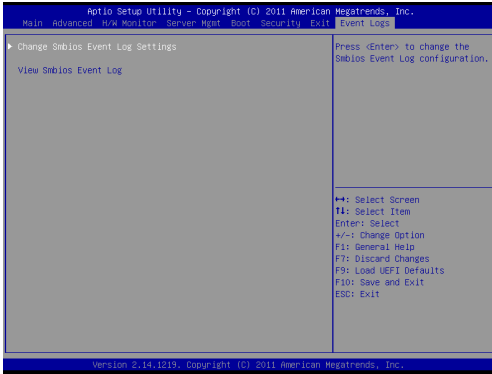

### Change Smbios Event Log Settings

This allows you to configure the Smbios Event Log Settings.

### View Smbios Event Log

This allows you to view the Smbios Event Log.

---

## **Chapter 4: Software Support**

### **4.1 Install Operating System**

This motherboard supports Microsoft® Windows® Server 2003 / 2003 R2 / 2008 / 2008 R2 / 2012 / 2012 R2 / Linux compliant. Because motherboard settings and hardware options vary, use the setup procedures in this chapter for general reference only. Refer your OS documentation for more information.

### **4.2 Support CD Information**

The Support CD that came with the motherboard contains necessary drivers and useful utilities that enhance the motherboard's features.

#### **4.2.1 Running The Support CD**

To begin using the support CD, insert the CD into your CD-ROM drive. The CD automatically displays the Main Menu if "AUTORUN" is enabled in your computer. If the Main Menu does not appear automatically, locate and double click on the file "ASRSETUP.EXE" in the Support CD to display the menu.

#### **4.2.2 Drivers Menu**

The Drivers Menu shows the available device's drivers if the system detects installed devices. Please install the necessary drivers to activate the devices.

#### **4.2.3 Utilities Menu**

The Utilities Menu shows the application softwares that the motherboard supports. Click on a specific item then follow the installation wizard to install it.

#### **4.2.4 Contact Information**

If you need to contact ASRock Rack or want to know more about ASRock Rack, you're welcome to visit ASRock Rack's website at <http://www.asrockrack.com>; or you may contact your dealer for further information.



---

## Chapter 5: Troubleshooting

### 5.1 Troubleshooting Procedures

Follow the procedures below to troubleshoot your system.



Always unplug the power cord before adding, removing or changing any hardware components. Failure to do so may cause physical injuries to you and damages to motherboard components.

1. Disconnect the power cable and check whether the PWR LED is off.
2. Unplug all cables, connectors and remove all add-on cards from the motherboard. Make sure that the jumpers are set to default settings.
3. Confirm that there are no short circuits between the motherboard and the chassis.
4. Install a CPU and fan on the motherboard, then connect the chassis speaker and power LED.

#### **If there is no power...**

1. Confirm that there are no short circuits between the motherboard and the chassis.
2. Make sure that the jumpers are set to default settings.
3. Check the settings of the 115V/230V switch on the power supply.
4. Verify if the battery on the motherboard provides ~3VDC. Install a new battery if it does not.

#### **If there is no video...**

1. Try replugging the monitor cables and power cord.
2. Check for memory errors.

#### **If there are memory errors...**

1. Verify that the DIMM modules are properly seated in the slots.
2. Use recommended DDR3 1600/1333/1066 ECC DIMMs.
3. If you have installed more than one DIMM modules, they should be identical with the same brand, speed, size and chip-type.
4. Try inserting different DIMM modules into different slots to identify

---

faulty ones.

5. Check the settings of the 115V/230V switch on the power supply.

### **Unable to save system setup configurations...**

1. Verify if the battery on the motherboard provides ~3VDC. Install a new battery if it does not.
2. Confirm whether your power supply provides adequate and stable power.

### **Other problems...**

1. Try searching keywords related to your problem on ASRock Rack's FAQ page:  
<http://www.asrockrack.com/support/faq.asp>
2. Try downloading and updating the latest UEFI on ASRock Rack's website:  
<http://www.asrockrack.com/support/download.asp>

---

## 5.2 Technical Support Procedures

If you have tried the troubleshooting procedures mentioned above and the problems are still unsolved, please contact ASRock Rack's technical support with the following information:

1. Your contact information
2. Model name, BIOS version and problem type.
3. System configuration.
4. Problem description.

You may contact ASRock Rack's technical support at:  
<http://www.asrockrack.com/support/tsd.asp>

## 5.3 Returning Merchandise for Service

For warranty service, the receipt or a copy of your invoice marked with the date of purchase is required. By calling your vendor or going to our RMA website (<http://www.asrockrack.com/support/index.asp?cat=RMA>) you may obtain a Returned Merchandise Authorization (RMA) number.

The RMA number should be displayed on the outside of the shipping carton which is mailed prepaid or hand-carried when you return the motherboard to the manufacturer. Shipping and handling charges will be applied for all orders that must be mailed when service is complete.

This warranty does not cover damages incurred in shipping or from failure due to alteration, misuse, abuse or improper maintenance of products.

Contact your distributor first for any product related problems during the warranty period.