

LCW620AD

Dual Monitor Wall Arm for up to 30" Monitors

The LCW620AD is a dual monitor mount with flexible articulating arms. Installation is quick and easy and allows positioning of the monitor for greater productivity. Instantly set the height of the monitor into a comfortable viewing position. A quick release mechanism instantly secures the monitor. Raise or lower the monitors, extend out, tilt forward and back, pan and rotate for portrait and landscape viewing.



FEATURES

- Each arm extends and adjusts for perfect positioning and ergonomic comfort to help reduce eye, back and neck strain
- Independent tension adjustment on the arm
- Tilt: +80°/-20°
Pan/Swivel: 180°
Rotate: 360°
- Portrait or landscape without removing the monitor
- Compatible with VESA® 75 and 100mm
- Can be used in laptop configuration with ACC329



Display size: up to 30"



Max load: 30lb (13kg)
Per arm: 15lb (7kg)



■ **QUICK RELEASE MECHANISM**
Monitors slide onto the pedestal and can be locked into place in seconds

■ **360° ROTATION**
Arm folds back into a compact retracted position

■ **CABLE MANAGEMENT**
Internal cable management keeps cables organized and out of the way



Quick release mechanism



Internal cable management



RoHS
COMPLIANT

Model Numbers

WARRANTY: Limited 5-year

LCW620AD Monitor Wall Arm for up to 30" monitors

Product Specifications

	DIMENSIONS (W x H x D)	PRODUCT WEIGHT	LOAD CAPACITY	FINISH	AVAILABLE COLORS
LCW620AD	9.00" x 3.94" x 24.76" (228 x 100 x 629mm)	8.0lb (3.6kg)	30.0lb (13kg)	Powder coat	Black

Package Specifications

	PACKAGE SIZE (L x W x H)	PACKAGE SHIP WEIGHT	PACKAGE UPC CODE	PACKAGE CONTENTS	UNITS IN PACKAGE
LCW620AD	5.50" x 17.50" x 22.12" (140 x 445 x 562mm)	13.0lb (5.8kg)	735029279921	Wall plate, two arms, two display mounts, mounting hardware	1

Accessories

- ACC918:** Security Fasteners
- ACC329:** Laptop Cooling Tray

All dimensions = inch (mm)

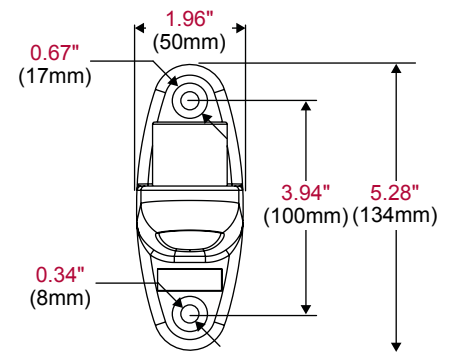
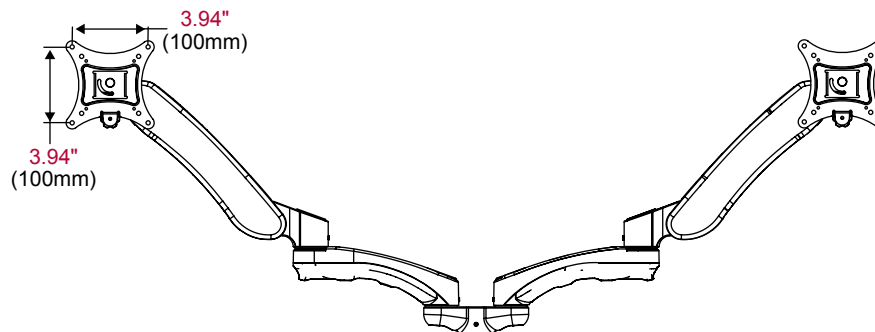
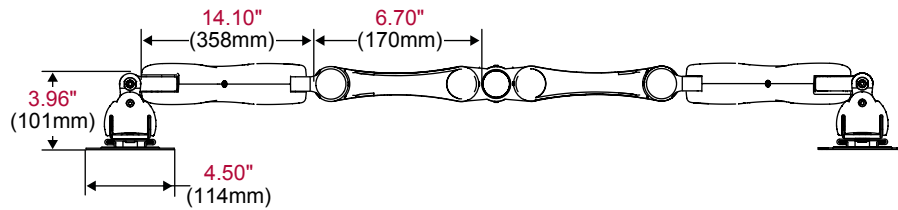

WALL PLATE

ARCHITECTS SPECIFICATIONS

The 620D-Series Wall Mount shall be a Peerless-AV model LCW620AD and shall be located where indicated on the plans. Assembly and installation shall be done according to instructions provided by the manufacturer.

Peerless Industries, Inc. ■ 2300 White Oak Circle ■ Aurora, IL 60502 ■ (800) 865-2112 ■ (630) 375-5100 ■ Fax: (800) 359-6500 ■ peerless-av.com

Visit peerless-av.com to see the complete line of AV solutions from Peerless-AV, including flat panel mounts, projector mounts, carts/stands, furniture, cables, screen cleaners and a full assortment of accessories.