



A SUPER RESOLUTION PERSPECTIVE



VIEW YOUR WORLD - IN SUPER RESOLUTION.

- ▶ CLEAR-NIGHT TECHNOLOGY
- ▶ VANDAL RESISTANT
- ▶ FLEXIBLE INSTALLATION

PROFESSIONAL-GRADE

For high performance video with Super Resolution (600 TVL) detail

WATCH DAY OR NIGHT

Digital Noise Reduction improves night vision clarity and recording efficiency

VERSATILE DESIGN

Install indoors or outdoors, on walls or ceilings

FEATURES

- Advanced Sony Super HAD™ II image sensor
- Video image processor delivers 600TV lines of resolution
- Night Vision up to 50ft (15m) away in total darkness¹
- ClearNight imaging technology ensures clear night vision and improves recording efficiency up to 30%
- 3.6mm wide angle lens for wide area coverage (80° FOV)²
- IP66 rated aluminum housing for indoor / outdoor installations³

FEATURES

600 TVL

50ft NIGHT VISION

INDOOR/OUTDOOR

RESOLUTION COMPARISON



Standard Resolution



Super Resolution

NIGHT VISION COMPARISON



Typical



With Advanced Digital Noise Reduction



LOREX[®]

VIEW YOUR WORLD™

SECURITY CAMERA

PRODUCT INFORMATION

LDC6051	7-78597-60510-5
Package Weight:	1.05 kg / 2.3 lbs
Package Dimensions: (W x D x H)	216mm/8.5" (w) x 172mm/6.7" (d) x 140.5mm/4.1 (h)
Package Cube:	0.13 Cbf / 0.003681 Cbm
Contents:	1x Camera, 1x 60ft BNC / Power extension cable 1x BNC female / RCA male adapter 1x 12V DC power adapter

SPECIFICATIONS

Image Sensor:	1/3" Sony Super HAD™ II
Video Format:	NTSC
Effective Pixels:	H: 768 V: 494
Resolution:	600 TV Lines
Scan System:	2:1 Interlace
Sync System:	Internal
S / N Ratio:	50dB (AGC Off)
Iris:	AES
AES Shutter Speed:	1/60 ~ 1/100,000 sec.
Min. Illumination:	0.2 Lux without IR LED 0 Lux with IR LED
Video Output:	Composite 1.0Vpp @ 75ohm
Lens / Lens Type:	3.6mm F2.0 / Fixed
FOV (Diagonal):	80°
Termination:	BNC Type
IR LED Qty / Type:	14 pieces / 850nm
Night Vision Range:	50ft. / 15m
Power Requirement:	12V DC ±10%
Power Consumption Max.:	250mA (w / IR)
Operating Temp. Range:	14° ~ 122°F / -10° ~ 50°C
Operating Humidity Range:	< 90% RH
Environmental Rating:	IP66
Weight (including stand):	0.8lbs. / 0.4kg

DISCLAIMERS

1. IR illumination range under ideal conditions. Objects at or beyond this range may be partially or completely obscured, depending on the camera application.
2. Field of view, diagonal.
3. Not intended for submersion in water. Installation in a sheltered location recommended.

INSTALLATION DIAGRAM

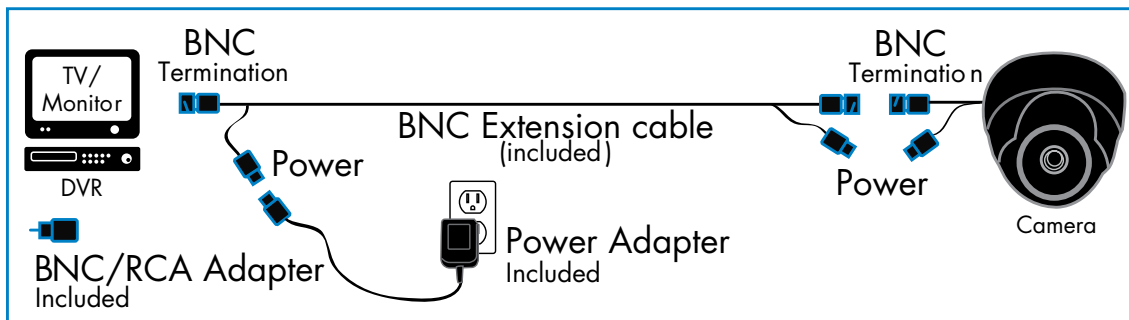

VANTAGE

LDC6051

www.lorexttechnology.com

Lorex Technology Inc.

250 Royal Crest Court, Markham,
Ontario L3R 3S1
Canada.

3700 Koppers Street
Baltimore, Maryland 21227,
USA.

As our product is subject to continuous improvement, Lorex Technology & subsidiaries reserve the right to modify product design, specifications & prices without notice and without incurring any obligation. E&OE.

©2011 Lorex Technology Inc.