

AXIS Q1931-E Thermal Network Cameras

Superior detection and wide range coverage.



- > Thermal imaging for IP-Surveillance
- > Bullet-style design
- > Multiple lens options
- > Intelligent video applications included
- > Power over Ethernet
- > Full duplex audio

AXIS Q1931-E Thermal Network Cameras are a perfect complement to any network video system that needs to secure an area or a perimeter 24 hours a day, seven days a week. The cameras use thermal imaging, which allows users to detect people, objects and incidents in complete darkness and difficult conditions such as smoke, haze, dust and light fog.

AXIS Q1931-E is a bullet-style outdoor-ready camera that is designed to withstand harsh weather conditions.

A resolution of 384x288 and a range of lenses make it possible to optimize detection performance to meet high security application requirements. Contrast enhancement and a frame rate of up to 30 fps improve thermal image quality, providing more pixels on target and enhancing the possibility to efficiently use the included intelligent video applications.

Since thermal cameras are less sensitive to problems with light conditions and shadows, they can achieve higher accuracy and less false alarms than conventional cameras in most applications.

AXIS Q1931-E offers built-in motion detection, cross-line detection and audio detection. The cameras also provide capacity for third-party analytics modules, including support for AXIS Camera Application Platform. AXIS Q1931-E cameras support ONVIF for interoperability between network video products.

Installation is made easy and cost-effective with Power over Ethernet (IEEE 802.3af). AXIS Q1931-E cameras support H.264 video compression, which reduces bandwidth usage and storage needs. The cameras provide multiple, individually configurable video streams in H.264 and Motion JPEG.



Range Chart

Wide range coverage for AXIS Q1931-E

	Focal length	Viewing angle	Human: 1.8 x 0.5 m Critical dimension: 0.75 m		Vehicle: 1.4 x 4.0 m Critical dimension: 2.3 m	
	mm	Horizontal	meters	yards	meters	yards
Detection (1.5 pixels on target) An observer can see an object	7	50°	220	240	675	740
	13	28°	390	430	1200	1300
	35	10°	1030	1130	3170	3460
	60	6°	1770	1930	5420	5920
Recognition (6 pixels on target) An observer can distinguish an object	7	50°	55	60	170	185
	13	28°	100	110	300	330
	35	10°	260	280	790	860
	60	6°	440	480	1350	1480
Identification (12 pixels on target) An observer can distinguish a specific object	7	50°	28	30	84	92
	13	28°	50	54	150	165
	35	10°	130	145	400	440
	60	6°	220	240	680	750

The ranges are calculated according to Johnson's criteria and vary in different weather conditions.

Environmental considerations

Johnson's criteria assume ideal conditions. The weather conditions at site will affect the thermal energy emitted from the object and decrease the effective detection range. The detection range in the tables above is based on a temperature difference of 2 °C between the targeted object and the background. However, weather conditions such as rain, snow and fog will attenuate the radiated energy from the object since the heat radiation from the object is scattered when it hits particles in the air. To avoid performance and reliability problems always test the camera in the actual environment where it should be used.

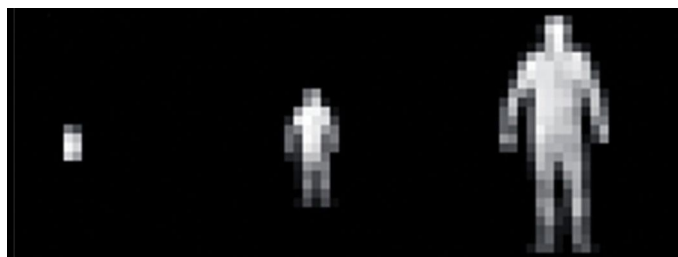

The difference in number of pixels between detection, recognition and identification illustrated with a human target.

Use of intelligent applications

The sensor in a thermal camera reacts to differences in thermal energy. Thus, the sensor is less sensitive to changing light conditions, darkness and other challenging conditions. This makes thermal cameras a perfect platform to combine with intelligent video applications to build more efficient 24/7 surveillance systems. Through our Application Development Partner Program Axis can offer the widest range of third party applications available.

Integrated with intelligent video applications such as video motion detection or tripwire, the camera can automatically trigger an alert to the operator. To maximize performance of the application and safeguard reliable operation 6 pixels across the object is recommended and the surrounding environment always needs to be considered.

Dimensions AXIS Q1931-E Thermal Network Camera

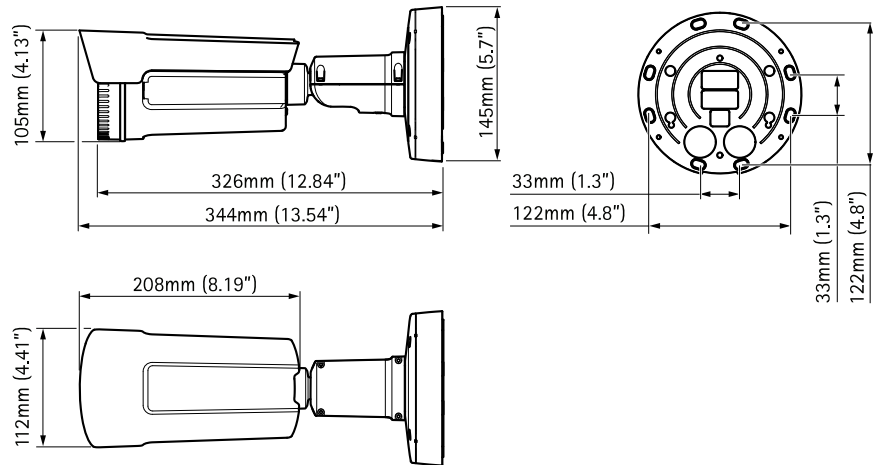

Optional accessories

1. AXIS T98A17-VE Surveillance Cabinet
2. AXIS Multicable A I/O Audio 5m

Power

3. AXIS T8120 Midspan 15 W 1-port
4. AXIS T8129 PoE Extender

Media converters

5. AXIS T8640 Ethernet over Coax Adapter PoE+
6. AXIS T8604 Media Converter Switch

Mounts

7. AXIS T91A47 Pole Mount 60mm-110mm
8. AXIS T91A47 Pole Mount 110mm-400mm
9. AXIS T94P01B Corner Bracket

1



2



3



4



5



6



7



8



9



Technical Specifications – AXIS Q1931–E Thermal Network Cameras

Models	Outdoor: AXIS Q1931–E, 7 mm, 13 mm, 35 mm and 60 mm	General	
Camera		Casing	IP66-rated metal casing (Aluminium) with integrated dehumidifying membrane and a germanium window
Image sensor	Uncooled Micro bolometer 384x288, pixel size: 17µm	Memory	256 MB RAM, 128 MB Flash
Light sensitivity	NETD < 70 mK	Power	Power over Ethernet IEEE 802.3af Class 3 8–20 V DC, max 11 W or 20–24 V AC 50–60 Hz, max 15 VA, power supply not included
Video		Connectors	RJ45 10BASE-T/100BASE-TX PoE, terminal block for power, eight circuit PCB header for two configurable inputs/outputs and audio
Video compression	H.264 (MPEG-4 Part 10/AVC) baseline profile and main profile Motion JPEG	Edge storage	MicroSD/microSDHC/microSDXC slot supporting memory card up to 64 GB (card not included) Support for recording to dedicated network-attached storage (NAS)
Resolutions	Sensor is 384x288 Image can be scaled up to 768x576	Operating conditions	–40 °C to 60 °C (–40 °F to 140 °F) Humidity 10–85% RH (condensing)
Frame rate	Up to 30 fps within EU, Norway, Switzerland, Canada, USA, Japan, Australia, New Zealand Up to 8.3 fps in other countries ^a	Approvals	EN 55022 Class B, EN 50121–4, EN 55024, EN 61000–6–1, EN 61000–6–2, FCC Part 15 Subpart B Class B, ICES–003 Class B, VCCI Class B, C-tick AS/NZS CISPR22 Class B, KCC KN22 Class B, KN24, IEC/EN/UL 60950–1, IEC/EN/UL 60950–22, EN 50581 (RoHS), IEC 60529 IP66, NEMA 250, IEC 60068–2–1, IEC 60068–2–2, IEC 60068–2–6, IEC 60068–2–27, IEC 60068–2–78, IEC 60721–3–4 Class 4K3, 4C3, 4S3, 4M4
Video streaming	At least 3 H.264 and Motion JPEG streams using the same palette, simultaneous and individually configured in max. resolution at 30 fps Controllable frame rate and bandwidth VBR/CBR H.264	Weight	AXIS Q1931–E 7 mm: 2000 g (4.4 lb) AXIS Q1931–E 13 mm: 2000 g (4.4 lb) AXIS Q1931–E 35 mm: 2100 g (4.6 lb) AXIS Q1931–E 60 mm: 2200 g (4.85 lb)
Image settings	Compression, Brightness, Exposure control, Rotation, Mirroring of images, Text and image overlay, Privacy mask	Included accessories	Wall and ceiling mount bracket, Installation Guide Installation and Management Software CD, Pipe converter for US, Windows decoder 1-user license Wall mount bracket, 5 m (16 ft) Ethernet cable
Audio		Video management software	AXIS Camera Companion (included), AXIS Camera Station and video management software from Axis' Application Development Partners (not included). For more information, see www.axis.com/products/video/software
Audio streaming	Two-way, full duplex	Warranty	Axis 3-year warranty, see www.axis.com/warranty
Audio compression	AAC LC 8/16 kHz, G.711 PCM 8 kHz, G.726 ADPCM 8 kHz Configurable bit rate		
Audio input/output	External microphone or line input, line output		
Network			
Security	Password protection, IP address filtering, HTTPS ^b encryption, IEEE 802.1X ^b network access control, Digest authentication, User access log		
Supported protocols	IPv4/v6, HTTP, HTTPS ^b , SSL/TLS ^b , QoS Layer 3 DiffServ, FTP, CIFS/SMB, SMTP, Bonjour, UPnP TM , SNMPv1/v2c/v3 (MIB-II), DNS, DynDNS, NTP, RTSP, RTP, TCP, UDP, IGMP, RTCP, ICMP, DHCP, ARP, SOCKS		
System integration			
Application Programming Interface	Open API for software integration, including VAPIX [®] and AXIS Camera Application Platform; specifications at www.axis.com AXIS Video Hosting System (AVHS) with One-Click Camera Connection ONVIF Profile S; specification at www.onvif.org		
Intelligent video	Video motion detection, Cross line detection, Audio detection, AXIS Camera Application Platform enabling installation of additional applications		
Event triggers	Intelligent video, Audio, Temperature, External input, Time scheduled, Edge storage events		
Event actions	File upload: FTP, HTTP, network share and email Notification: email, HTTP and TCP External output activation Pre- and post-alarm video buffering Video and audio recording to edge storage		

- a. *Frame rate above 9 fps may be subject to export control regulations*
b. *This product includes software developed by the OpenSSL Project for use in the OpenSSL Toolkit (<http://www.openssl.org/>), and cryptographic software written by Eric Young (ey@cryptsoft.com).*

More information is available at www.axis.com