



Suitable for pole & flush mounted projectors



Max weight capacity 22.7kg (50lbs)



Suits suspended ceiling structures



Allows alignment/focus adjustment

The Telehook 8" and 24" Ceiling Tiles are designed to assist with the mounting of projectors into a suspended ceiling; providing a safe and secure attachment point, improving the finished appearance, and enhancing cabling / connection option. PT24 is designed to slot directly into a 24" grid as a replacement tile while the PT8 is designed to be hidden above alternative grid configurations and ceiling types. Both are compatible with the Telehook Flush and Pole mounts, as well as 3rd party mounts which conform to the US 1.5" NPT standard. The tiles come with attachment hardware to suit a variety of roofing structures and feature removable panels for connector block / socket socket installation. Depending on the installation orientation they can enable fine adjustment for either focal length or screen alignment.



Product key features:

- Designed to be used with Atdec Telehook and third party projector mounting solutions
- Suit standard 8" and 24" tile matrix configurations
- Can be also used with non-standard tile configurations and ceiling types (PT8 only)
- Removable panels allow for connector block / plug mounting
- Supplied with mounting hardware to suit timber, concrete and truss beam ceiling supports
- Gloss white finish which can be painted if required
- Supplied with a security / safety tie
- Supplied with an installation guide



Removable panels allow for connector block mounting

Available in two sizes; 8" (TH-PT-8) and 24" (TH-PT-24)

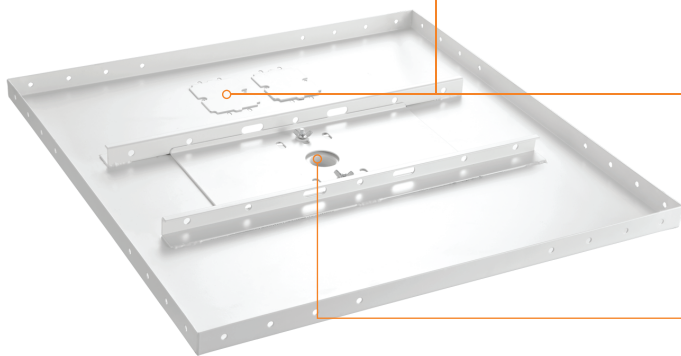

Allows focal length / alignment adjustment

Also compatible with standard 1.5" NPT mounts



Compatible with Telehook TH-WH-PJ-FM and TH-WH-PJ-CM mounts



Product information, single unit

Model code	Load capacity	Material	Color
TH-PT-8 / TH-PT-24	22.7Kg (50lbs)	Steel	Gloss white

Package information, single unit

Product	Size	Ship weight	UPC code	Contents
TH-PT8	680mm x 250mm x 90mm (26.8" x 9.8" x 3.5")	4kg (8.8lbs)	88 1493006447	Tile & ceiling covers, support wire and turn buckles, concrete and timber eye bolts, safety wire and clamps, NPT bracket and attachment screws
TH-PT24	655mm x 650mm x 90mm (25.8" x 25.6" x 3.5")	9kg (19.8lbs)	88 1493006430	

Package information, master pack

Product	Size	Ship weight	UPC	Units per master pack
TH-PT8	705mm x 260mm x 375mm (27.8" x 10.2" x 14.8")	10kg (22lbs)	88 1493006454	4
TH-PT24	N/a	N/a	N/a	1

Technical drawings

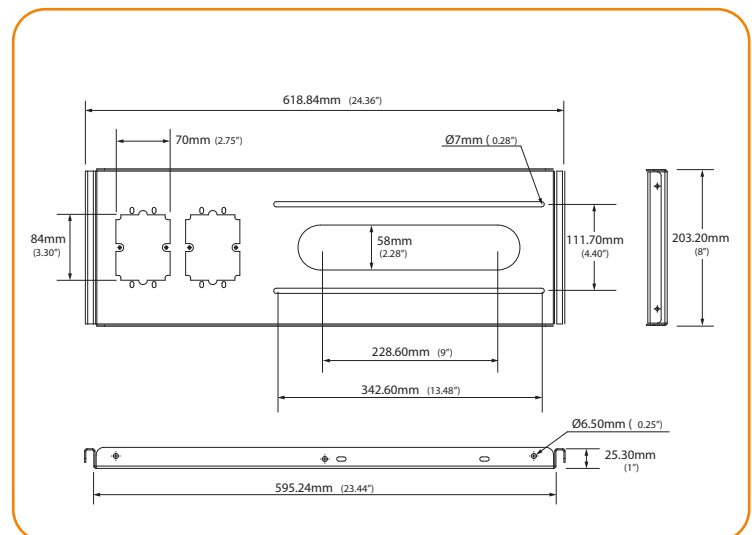
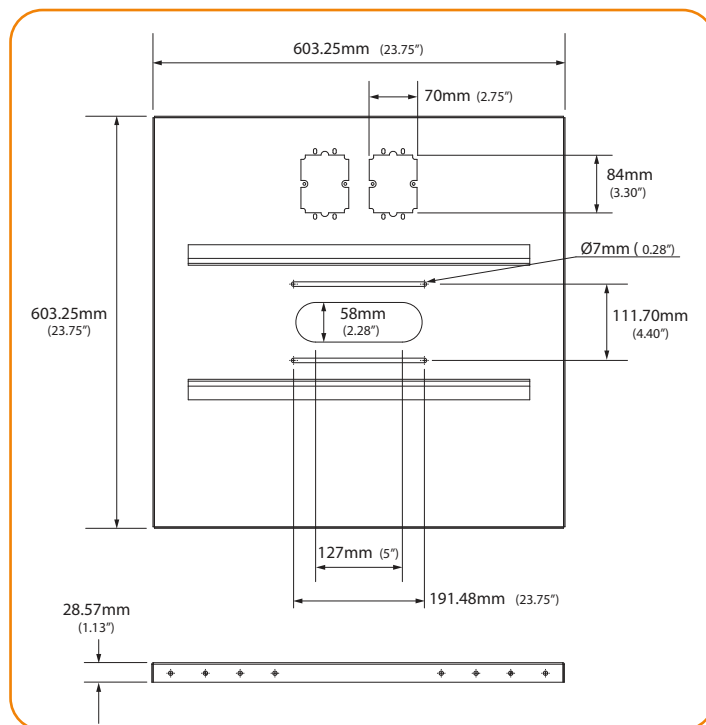

Related Products

TH-WH-PJ-CM	Projector Pole Mount
TH-WH-PJ-FM	Projector Flush Mount