



Focus | Wall mounted monitor arm VF-AT-W

The Visidec Focus VF-AT-W wall mount combines ergonomic functionality with effortless adjustability. Its sleek and contemporary design features an elegant polished aluminium finish that will add style to any home, office or retail environment. The articulated arm allows for an attached screen to be pulled out from the wall and subsequently folded back. The viewing angle can be adjusted and the screen orientation rotated from landscape to portrait. Height adjustment is also possible while cables are managed internally for a clean and uncluttered workspace.



Mounting hole pattern:
75x75mm & 100x100mm mounting
(100x200mm optional)*



Maximum weight carrying capacity:
8kg (17.5lbs)



Product key features:

- ✕ Sleek and contemporary design
- ✕ Durable materials (die-cast anodised aluminium)
- ✕ Arm maximum reach: 454mm (17.8")
- ✕ Display height adjustment range: 128mm (5")
- ✕ Comes with all mounting hardware



FlexiStar™ mechanism to support 75x75 and 100x100 VESA mounting hole patterns



Adjustable tilt: 70° up and 70° down

Offers a wide range of movement via 3 pivot points

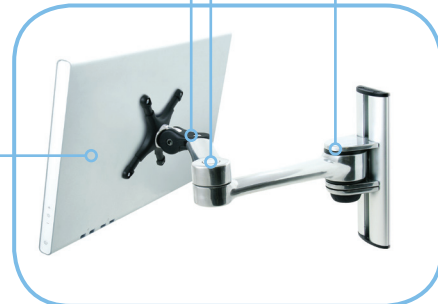

Portrait to landscape rotation

Unique locking mechanism supports the screen weight during height adjustment

Advanced cable management

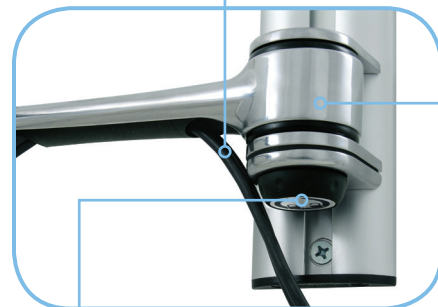

Tool-less height adjustment

Adjustable pan: 90° left and 90° right



Atdec Global www.atdec.com.au
Atdec North America www.atdec.com

Product information

| Product Code | Load capacity | Material | Colour |
|--------------|---------------|----------|-------------------|
| VF-AT-W | 8kg (17.5lbs) | Aluminum | Polished Aluminum |

Package information, single unit

| Size (L x W x H) | Ship weight | UPC code | Contents |
|--------------------------------------------|---------------|--------------|-------------------------------------------------|
| 32cm x 17cm x 12cm (12" x 6.5" x 4.75") | 1.4kgs (3lbs) | 881493004382 | All hardware required for installation supplied |

Package information, master pack

| Size (L x W x H) | Ship weight | UPC code | Units per master pack |
|-----------------------------------------|----------------|--------------|-----------------------|
| 87cm x 36cm x 26cm (34" x 13" x 10") | 15kg (33.2lbs) | 881493004399 | 10 |

Technical drawings

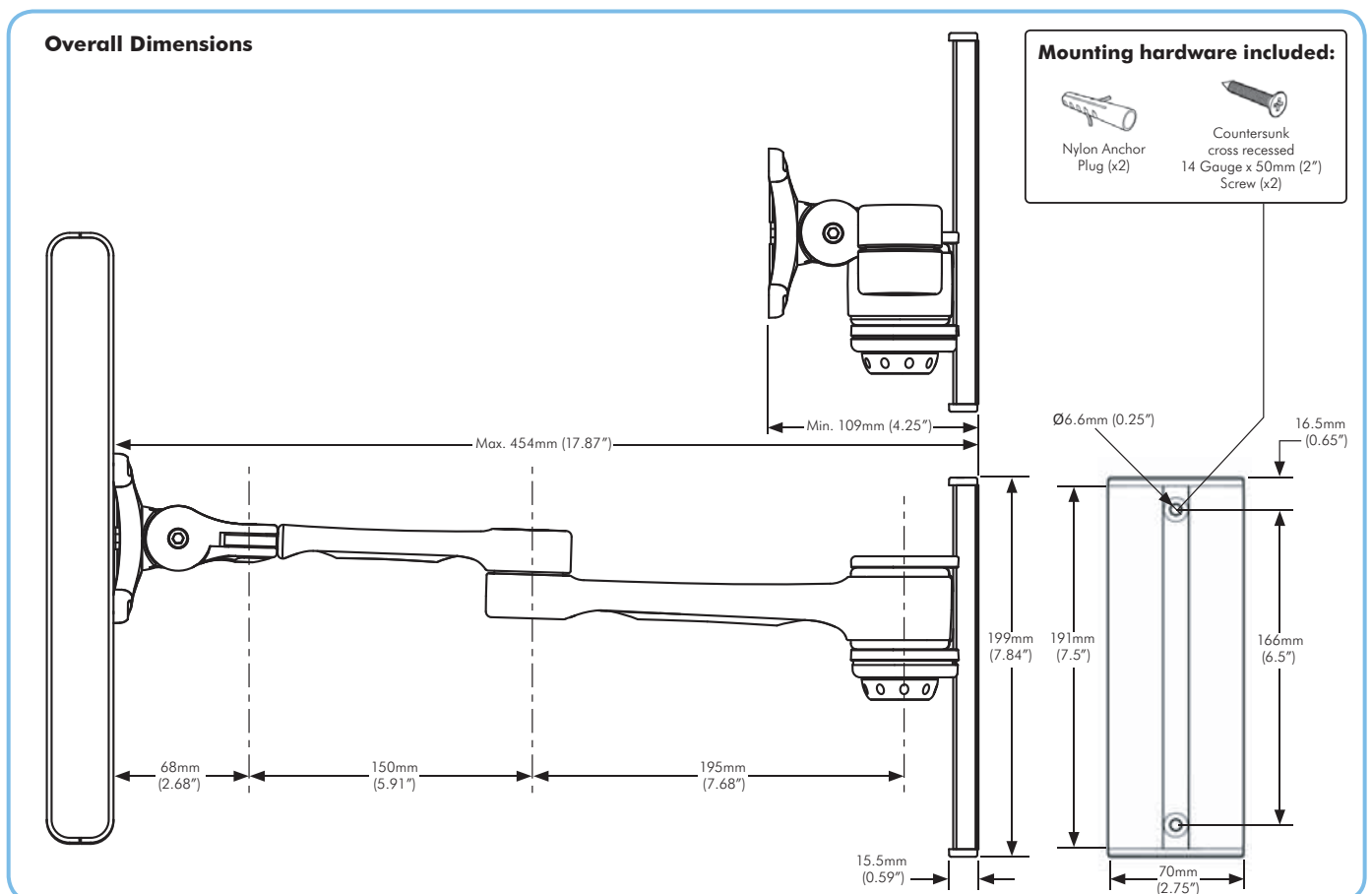

Atdec mounts are designed, developed and tested in Australia. We manufacture an extensive range of display and projector mountings for a variety of user types and situations. While all efforts have been made to ensure the information in this brochure was correct as of the date of printing, we reserve the right to change specifications without notice. Please refer to the website for our full range along with the latest details on specifications, compatibility and dealer location. Atdec and Visidec are registered trademarks with all rights reserved. Copyright July 2012.



Atdec Global www.atdec.com.au
Atdec North America www.atdec.com