

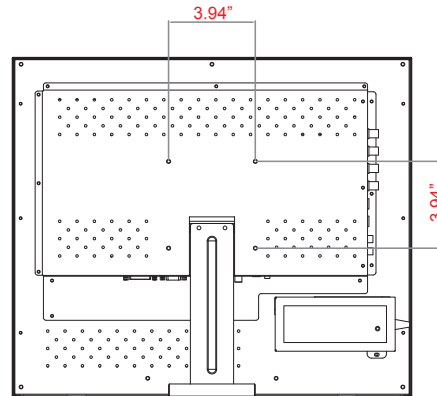

MODEL #	VZ-20RTH
DISPLAY	
Screen Size	20"
Max. Resolution	1600 x 1200 @60Hz
Pixel Pitch	0.255mm x 0.255mm
Brightness	300cd/m²(Typical)
Contrast Ratio	800:1
Aspect Ratio	4 : 3
Viewing Angle (H/V)	178°/178°
Display Color	16.7 Million
Response Time	< 16ms
Video System	NTSC / PAL
Frequency (H)	31 ~ 80Khz
Frequency (V)	56 ~ 75Hz
INTERFACE	
AV(Composite) In/ Out	2 / 2
S-Video In / Out	1 / 1
RGB In(15Pin D-Sub)	1
Component(Y, Pb, Pr, Sound L/R) In	1
DVI-In	1
HDMI1 / HDMI2 In	1 / 1
Trigger In	1
AV(Composite) Sound In/Out (RCA Type)	2 / 2
PC Stereo In/Out	1 / 1
AUDIO	
Built in speaker	2W x 2
SPECIAL FEATURES	
Multi Display Function	PIP / PBP / VOV
Filter Type	3D Comb filter / DeInterlace
LCD Protection Glass	YES
Trigger Sensor / Image Rotation	YES / Not Available
Video Resolution(Max)	600 TV Line
Camera Mounting Hole	1(Bottom)
Multi-lingual Language	English, Spanish, French, German, Italian, Portuguese, Dutch
DIMENSIONS	
Outline Dimension (W x H x D)	18.13" x 15.35" x 3.19"
Net Weight	(460.4mm x 390.0mm x 81.0mm) 17.90 lbs (8.12kg)
MOUNT	
VESA	100mm x 100mm, M4x10 Screws
GENERAL	
Transmitter - IR Remote Control	YES
Power - Electrical Ratings - Consumption	DC 12V / 5A(AC100 ~ 240V[50/60Hz]) 35W
Warranty - Parts/ Labor - MTBF (Approx.)	3 Year / 3 Year 50,000 Hours
Operating Temperature	32 - 104°F / 0 - 40°C
Regulations	UL, CB, FCC(B), CE-Emc(LVD)
Compatible Mounts - WALL - CEILING - Rack	VZ-WM05, VZ-WM10, VZ-WM31 VZ-CMK01, VZ-CMK-05 VZ-RMK08

VZ-20RTH ADVANTAGES:

- 20" LCD CCTV Monitor
- BNC, VGA, HDMI, DVI
- 3D Comb-filter, De-interlace, Built-in Speakers
- 3-Year Warranty

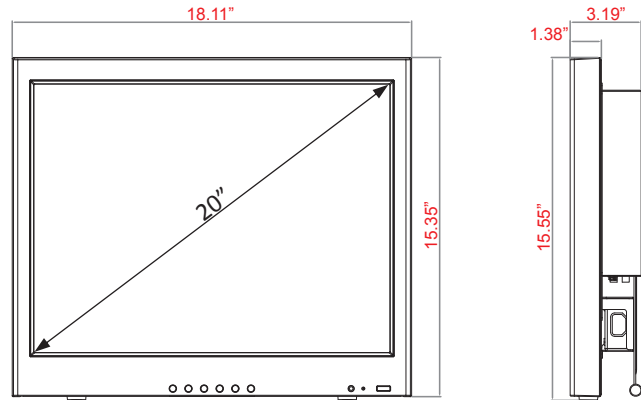

INTERFACE

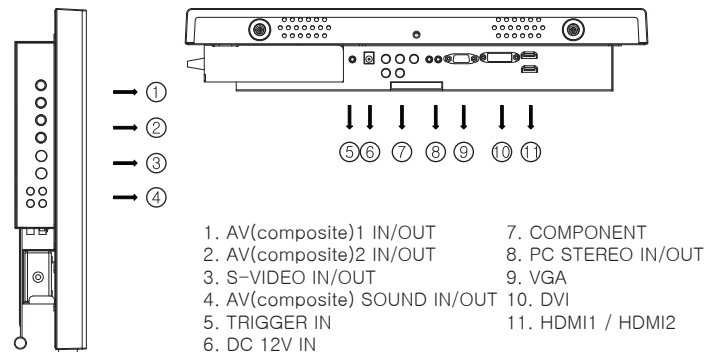

Contact ViewZ

- Address: 1220 N.Kraemer Blvd, Anaheim, CA, 92806
- Phone: (714)630-3380, Fax: (714)630-2335
- Sales: sales@viewzusa.com
- Specifications subject to change without notice.