

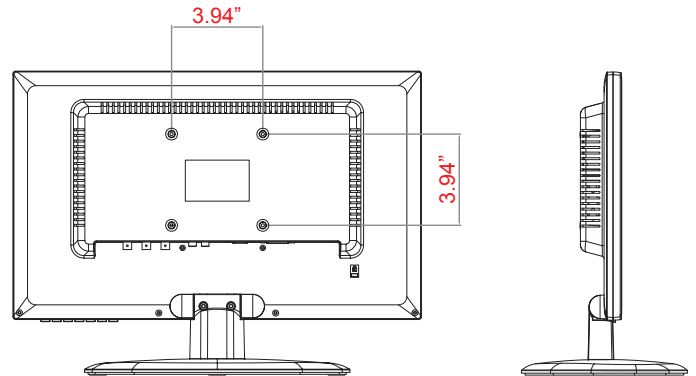

MODEL #	VZ-215LED-P
DISPLAY	
Screen Size	21.5"
Max. Resolution	1920 x 1080 @60Hz
Pixel Pitch	0.248mm x 0.248mm
Brightness	250cd/m²(Typical)
Contrast Ratio	1000:1
Aspect Ratio	16 : 9
Viewing Angle (H/V)	170°/160°
Display Color	16.7 Million
Response Time	< 5ms
Video System	NTSC / PAL
Frequency (H)	31 ~ 80Khz
Frequency (V)	56 ~ 75Hz
INTERFACE	
AV(Composite) In/ Out	2 / 1
S-Video In / Out	N / A
RGB In(15Pin D-Sub)	1
Component(Y, Pb, Pr, Sound L/R) In	N / A
DVI-In	1
HDMI In	1
Trigger In	1
AV(Composite) Sound In/Out (RCA Type)	1 / 0
PC Stereo In/Out	1 / 0
AUDIO	
Built in speaker	2 W x2
SPECIAL FEATURES	
Multi Display Function	PIP / PBP / VOV
Filter Type	3D Comb filter / DeInterlace
Video Resolution(Max)	600 TV Line
Multi-lingual Language	English, Spanish, French, Italian Dutch, Portuguese or Nederland
DIMENSIONS	
Outline Dimension (W x H x D)	20.25" x 14.56" x 1.77" (514.5mm x 370.0mm x 44.96mm)
Net Weight	8.4 lbs (3.81kg)
MOUNT	
VESA	100mm x 100mm, M4x10 Screws
GENERAL	
Transmitter - IR Remote Control	YES
Power - Electrical Ratings	DC12V(AC100 ~ 240V[50/60Hz])
- Consumption	21.6W
Warranty - Parts/ Labor	3 Year / 3 Year
- MTBF (Approx.)	50,000 Hours
Operating Temperature	32 - 104°F / 0 - 40°C
Regulations	TUV-NRTL (=UL), CB, FCC(A), CE-Emc(LVD)
Compatible Mounts - WALL	VZ-WM05, VZ-WM10, VZ-WM31
- CEILING	VZ-CMK01, VZ-CMK05
- RACK	N / A

VZ-215LED-P ADVANTAGES:

- 1080p Resolution
- 40% Lower Power Consumption
- BNC, HDMI, DVI, VGA
- 3D Comb-filter, De-interlace, Built-in Speakers
- 3-Year Warranty

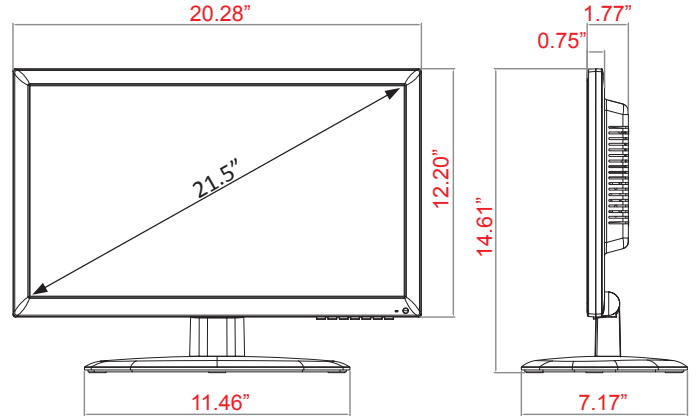

INTERFACE

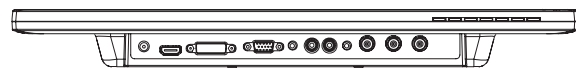

- | | |
|---------------------------|-----------------------|
| 1. DC12V IN | 7. TRIGGER IN |
| 2. HDMI | 8. AV(composite)1 IN |
| 3. DVI | 9. AV(composite)1 OUT |
| 4. VGA | 10. AV(composite)2 IN |
| 5. PC STEREO IN | |
| 6. AV(composite) SOUND IN | |

Contact ViewZ

- Address: 1220 N.Kraemer Blvd, Anaheim, CA, 92806
- Phone: (714)630-3380, Fax: (714)630-2335
- Sales: sales@viewzusa.com
- Specifications subject to change without notice.