

19" CLASS (18.5" MEASURED DIAGONALLY)

E1942S

LCD
MONITOR

LED Back-lit Commercial Monitor



EXPAND YOUR VIEW - WIDE FORMAT MONITOR

Go Wide with LG's E1942S WIDESCREEN Monitor. Designed with a remarkable 30000:1 Digital Fine Contrast, 5ms response and 16.7 million colors. As a result, your images are rendered with striking effect while text comes through sharp. From web browsing to desktop publishing, the E1942S wide screen monitor can enhance productivity in professional environments.

REMARKABLE DFC 5,000,000:1 RATIO

5MS RESPONSE TIME

TILT ADJUSTABLE STAND

INTEGRATED F-ENGINE™
(picture-quality enhancing chip)

VESA™ COMPLIANT WALL MOUNTABLE

 SUPER ENERGY SAVING

3 YEAR LIMITED WARRANTY
(parts/labor/backlight)

LGsolutions.com



LG
Life's Good

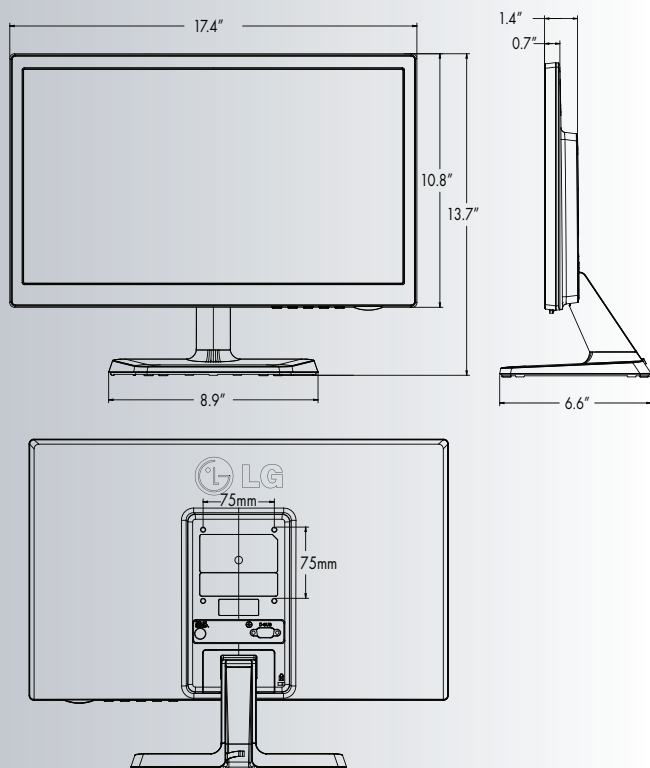

DIMENSIONS

SPECIFICATIONS

DISPLAY

LCD Panel Type	19" class
Display Area	18.5" measured diagonally
Color	Black
Color Gamut (CIE1931)	72%
Color Depth	16.7 Million Colors
Pixel Pitch	0.3mm
Aspect Ratio	16:09
Maximum Resolution	1366 x 768
Brightness	250 cd/m ²
Contrast Ratio	1,000:1, DFC 5,000,000:1
Response Time	5ms
Viewing Angle (HxV)	170°/160°
Surface Treatment	Non-Glare

USER INTERFACE

PC Input	D-Sub
----------	-------

POWER

Input	100~240V
Normal Usage	15W
Stand-by Usage	0.3W

FREQUENCY

Analog	H-Frequency	30~61KHz
	V-Frequency	56~75Hz

RESOLUTION

PC	Analog	1360 x 768
----	--------	------------

DIMENSIONS

Set w/Stand (W x D x H)	17.4" x 6.6" x 13.7"
Set w/o Stand (W x D x H)	17.4" x 2.2" x 10.8"
Box	20.0" x 13.3" x 4.5"

WEIGHT

Set w/Stand	4.6 lbs
Set w/o Stand	4.2 lbs
Box	7.1 lbs

STAND

Base Detachable
Tilt (-5° Front ~ 20° Rear)

CERTIFICATIONS

Safety	TCO5.2, UL (cUL), TUV-GS (TUV-Type), SEMKO
EMC	FCC-B, CE
EPA	Yes
VESA Mounting	75mm x 75mm
Microsoft Logo	Windows 7

SPECIAL FEATURES

Picture Mode
PC, 4:3 in Wide (ARC)
Intelligent Auto (Auto Resolution)
Photo Effect
sRGB
Plug & Play - DDC2B, DDC/CI
Super Energy Saving

ACCESSORIES

Power Cord (Option)
D-Sub Cable

LIMITED WARRANTY

3 Years (parts/labor/backlight)
Swap Program available
Call Toll-Free 1-800-243-0000

UPC CODE

7 19192 19026 9

LGSolutions.com



LG Electronics U.S.A., Inc.
HE B2B Division
2000 Millbrook Drive
Lincolnshire, IL 60069

Customer Service: 888.865.3026
www.LGSolutions.com/support

Contact your LG Regional Sales Representative:
Channel: 800.897.8871
Hospitality: 800.228.1236
E-mail: info@LGSolutions.com

SPEC_E1942S_041203_PR



All screen images are simulated. Dimensions and weights are approximate. Design, features and specifications subject to change without notice.

© Copyright 2012 LG Electronics USA, Inc. All Rights Reserved. "LG Life's Good" is a registered trademark of LG Corp. VESA is a trademark of Video Electronics Standards Association. All other product and brand names are trademarks or registered trademarks of their respective companies.

Printed in the USA. April 2012



LG

Life's Good