

A

B

C

D

E

F

G

H

A

B

C

D

E

F

G

H

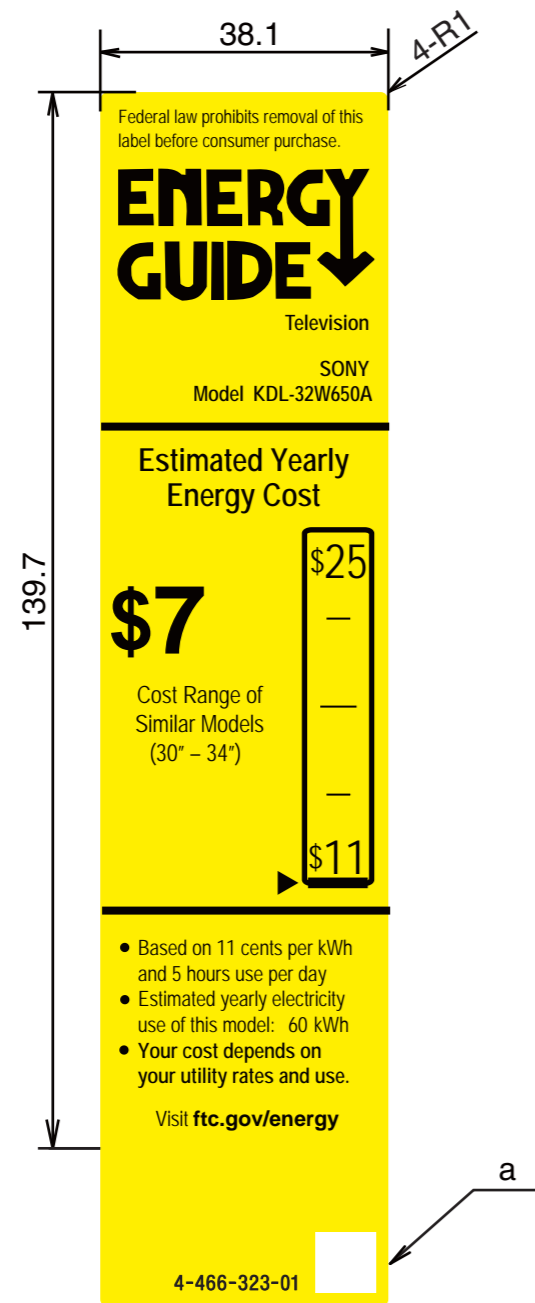

<ARTWORK TEMPLATE>

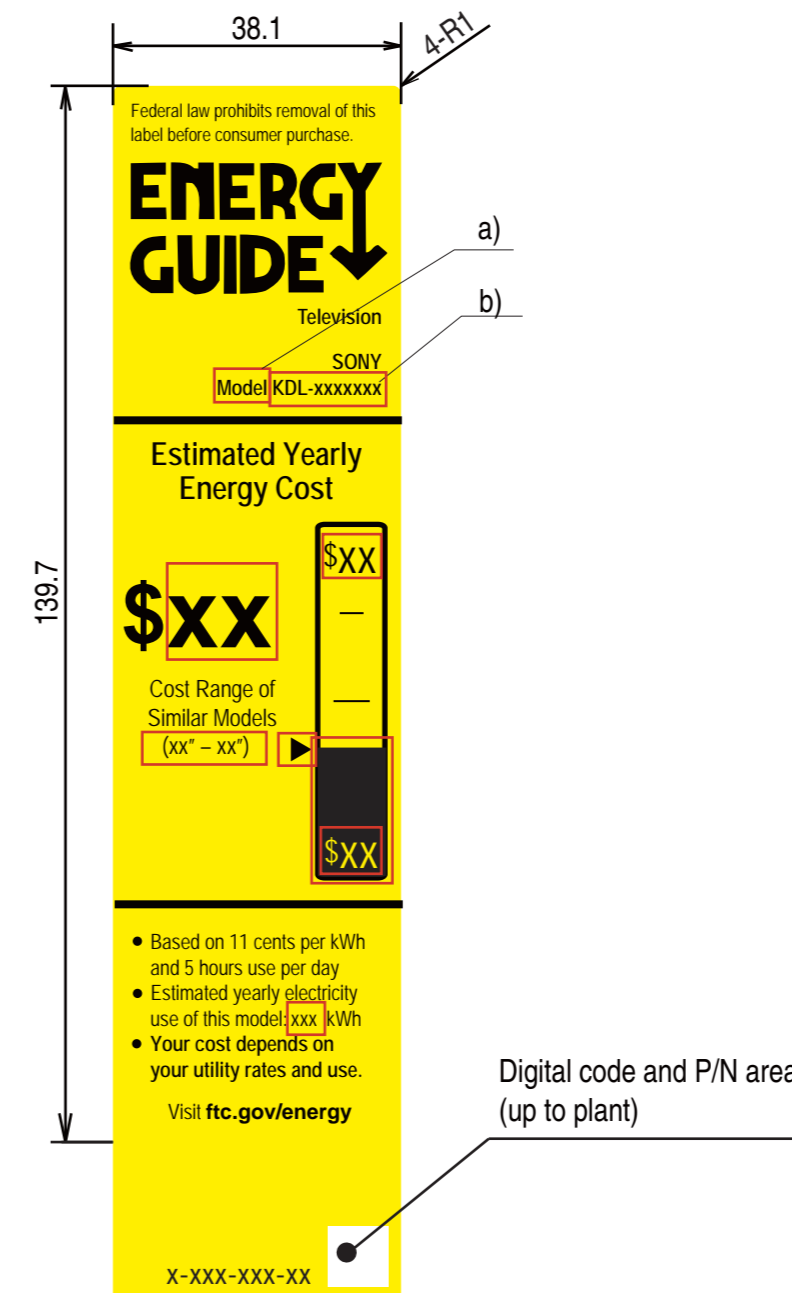

<BACK SIDE>

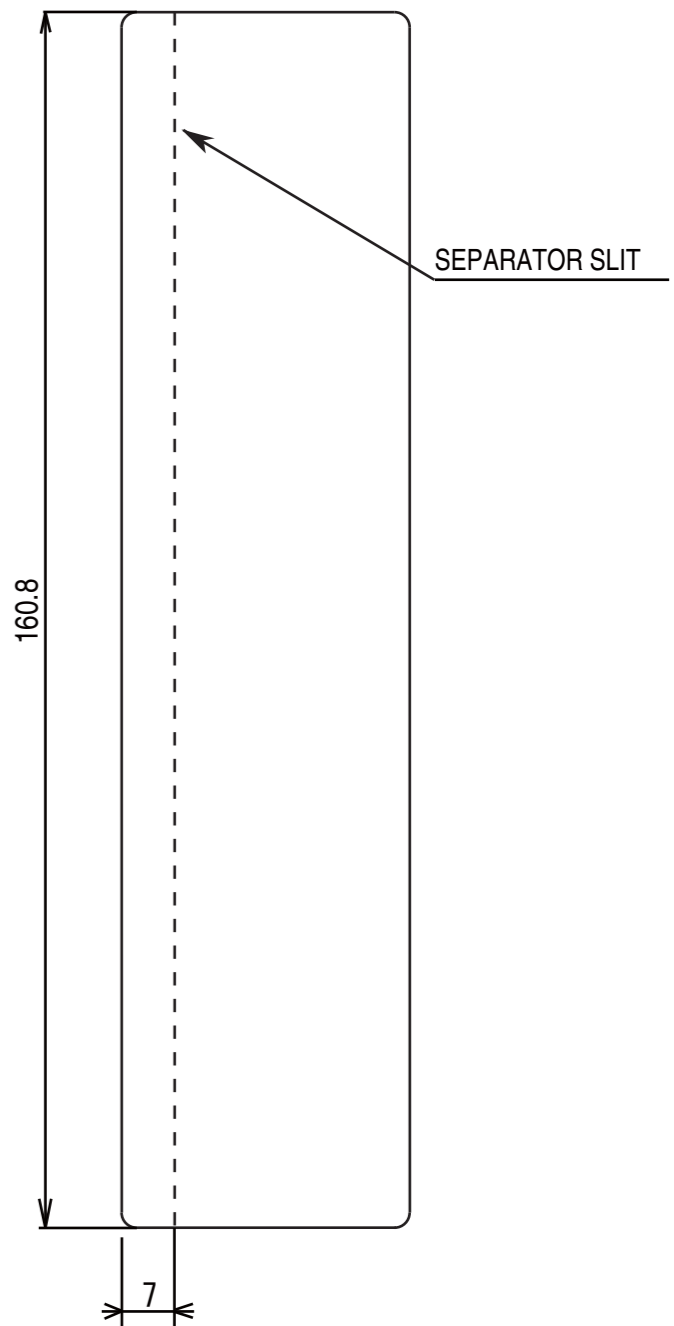

Red frames are data change needs.



- a) Same label has one model → Model
- Same label has a few models → Models

- b) If same label has suffix difference of model name, suffix should be 'X'

ex. KDL-32EX720 → KDL-32EX72X
 KDL-32EX721 → KDL-32EX72X

| SUFFIX | MODEL NAME | ORIGINAL MODEL | TOOL LOCATED |
|--------|-------------|----------------|--------------|
| -01 | KDL-32W650A | SV-24033(LA1) | USA |

QR Code
 Parts No.(Without "-")
 BLACK

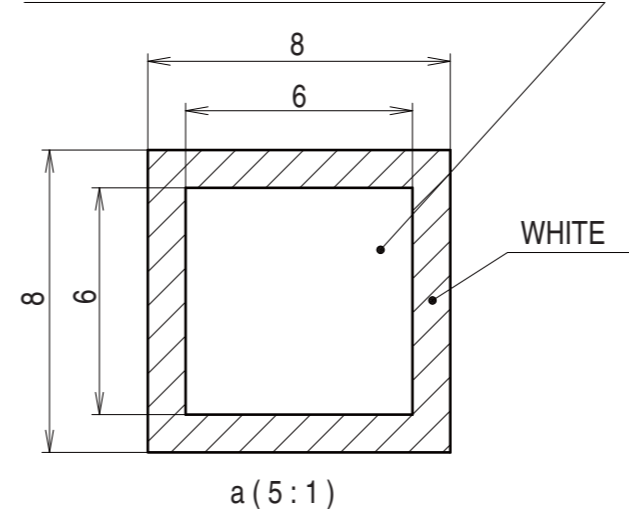

MATERIAL STRUCTURE

- LAMINATION PET 16 micron
- ADHESIVE NPL
- Printed Surface
- Synthetic Paper Yupo 1.0.08 (Yupo 80)
- Adhesive (M4)
- Release Paper

THIS PARTS SHOULD NOT CONTAIN ANY SUBSTANCES WHICH ARE SPECIFIED IN SS-00259-1.
 PURCHASE RECYCLED RESINS AND WIRE RODS ONLY FROM THE BUSINESS PARTNERS THAT SONY APPROVES AS GREEN PARTNERS.

| UNIT | TOLERANCE | ST S-3 | USED ON | RANK |
|------------------------------|---------------------|----------------|---------|------------------------------|
| mm | L ≤ 410.2 | | | |
| ANGLE | 4 < L ≤ 16 ±0.3 | | | FAMILY |
| | 16 < L ≤ 63 ±0.4 | | | |
| | 63 < L ≤ 250 ±0.5 | | | |
| SCALE | 250 < L ≤ 400 ±0.7 | | | |
| | 400 < L ≤ 1000 ±1.5 | | | |
| | 1000 < L ≤ 2000 ±3 | | | ORIGINAL MODEL SV-24033(LA1) |
| | 2000 < L ≤ 4000 ±4 | | | |
| MATERIAL(COLOR) | | FINISH(COLOR) | | |
| ABOVE | | COLOR PRINTING | | |
| DESCRIPTION | | | | |
| (B) LABEL, ENERGY GUIDE(MBB) | | | | |
| (I) LABEL, ENERGY GUIDE(MBB) | | | | |
| PART NO. | | | | SHEET |
| 4-466-323-01 | | | | |