

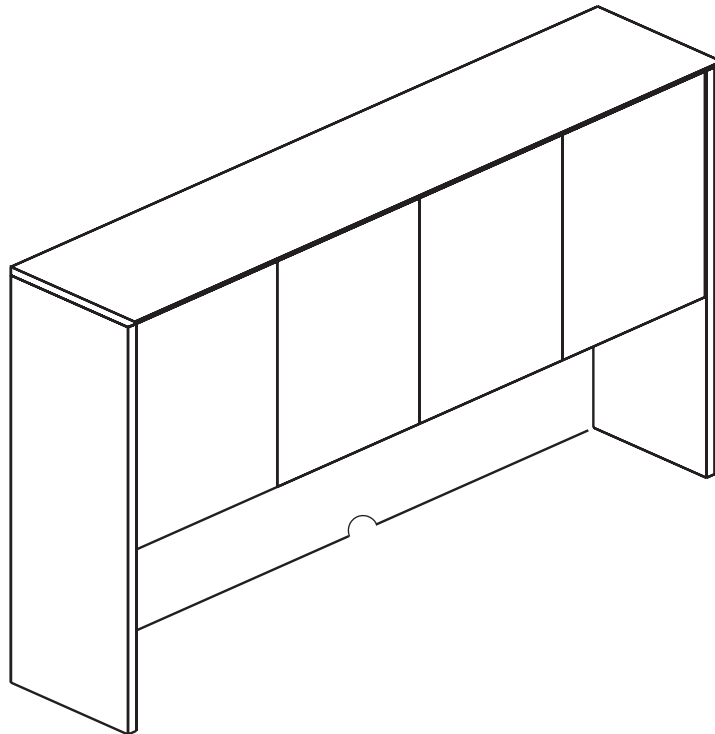





Tiffany Industries™
A MAYLINE GROUP COMPANY





Corsica Hutch, Wood Doors Model No. CHTC66/72/84

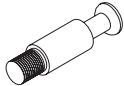

ASSEMBLY INSTRUCTIONS
CALL 1-800-822-8037 FOR ASSISTANCE



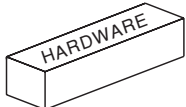

PARTS LIST

Name	Part	Qty.	Spare Qty
A*	 HB REALS001 Cam Fastener	12	1
B*	 HB REALS002 Cam Cap	8	1
C*	 HB REALS004 Wood Dowel	12	1
D*	 HB REALS003 Cam Post	12	1

Name	Part	Qty.	Spare Qty
E*	 HB REALS018 4mm x 14mm	4	1
F*	 HB REALS006 Cap	4	
G	 REALS046 4mm x 25mm	4	1
H*	 REALS042 Connection Bracket	2	
	 HARDWARE CHTCHB		

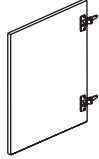
items with HB are in the hardware box.
 *For Individual Items, Order By Part Number.
 ** Denotes Color Code

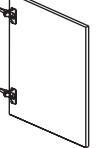
PARTS LIST

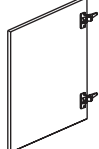
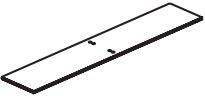
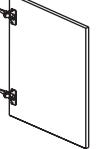
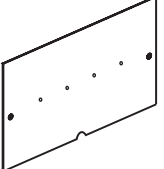
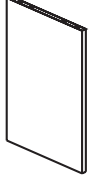
Name	Part	Qty.	Name	Part	Qty.
K*	 CHTC~~K** Top	1	O1*	 CHTC~~O** Left Outside Door	1
L1*	 CHTCL1** Left Panel	1	O2*	 CHTC~~O** Left Inside Door	1
L2*	 CHTCL2** Right Panel	1	O3*	 CHTC~~O** Right Inside Door	1
M*	 CHTC~~M** Shelf	1	O4*	 CHTC~~O** Right Outside Door	1
N*	 CHTC~~N** Back Panel	1	P*	 CHTCP** Center Support	1

*NOTE: When ordering replacement doors (CHTC~~O**) you will get a PAIR of doors.

*For Individual Items, Order By Part Number.

** Denotes Color Code

~~ Denotes Size (66, 72, 84)

1

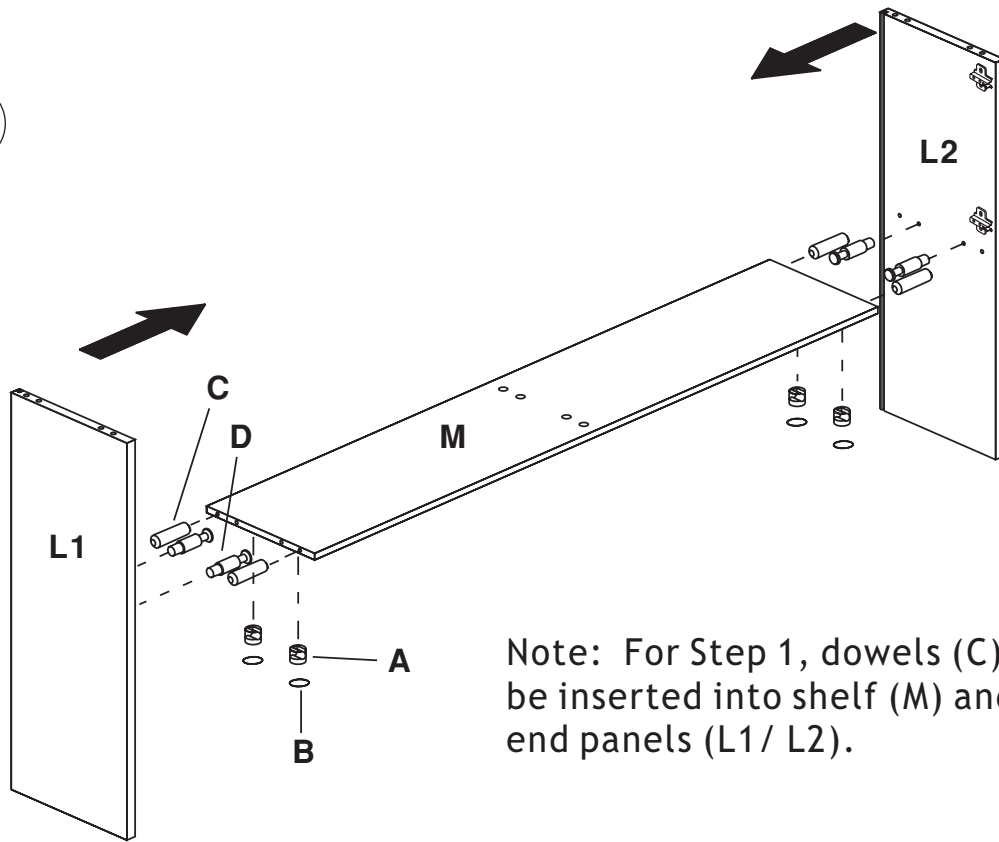

Note: For Step 1, dowels (C) are to be inserted into shelf (M) and not end panels (L1/ L2).

2

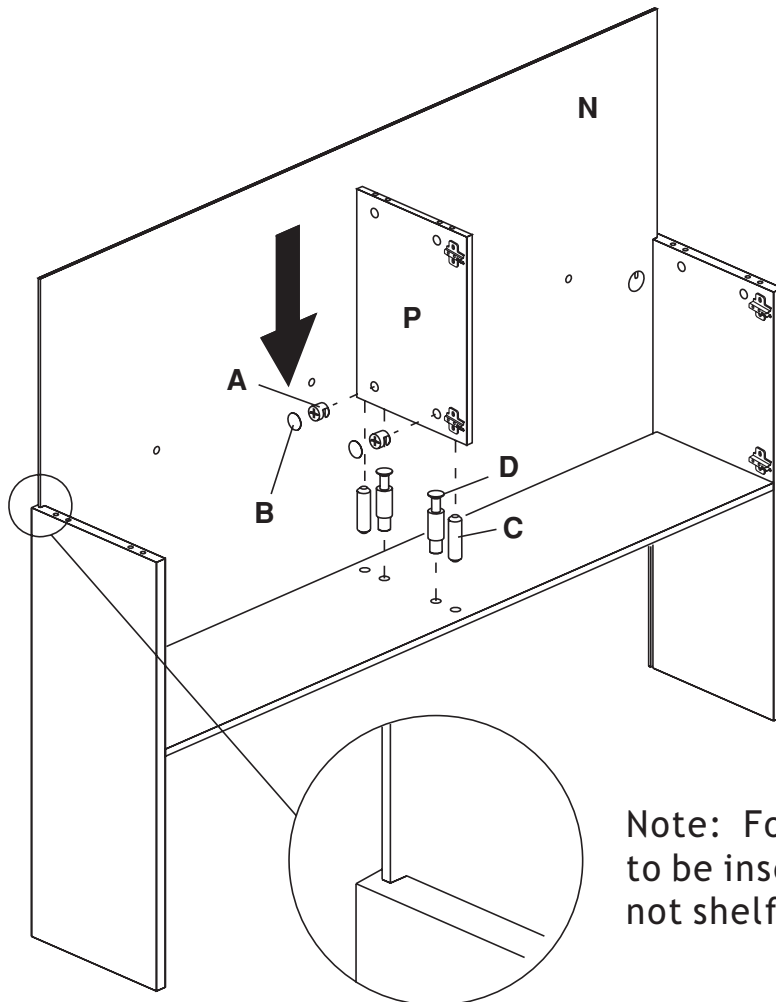

Note: For Step 2, dowels (C) are to be inserted into divider (P) and not shelf (M).

3

3

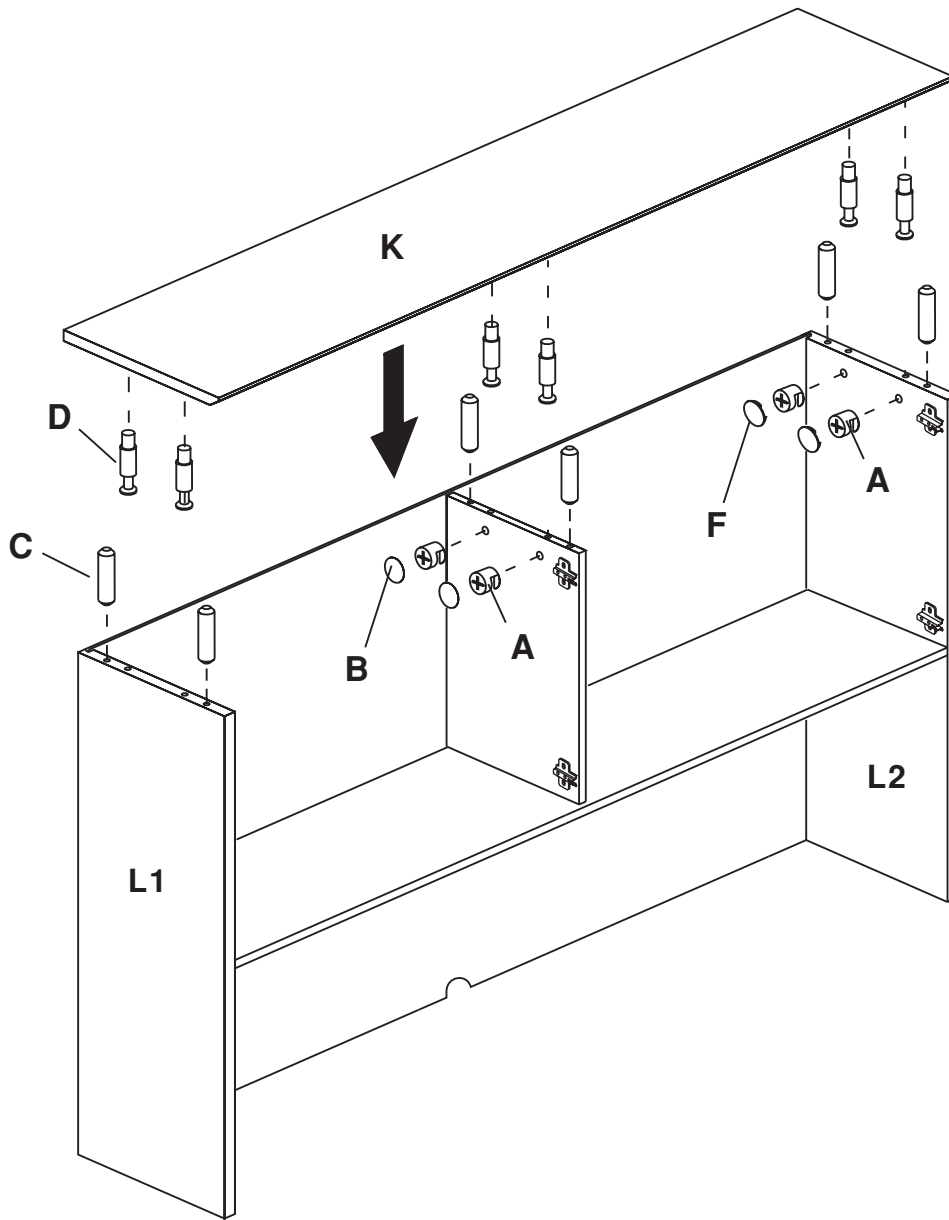

Note: For Step 3, dowels (C) are to be inserted into end panels (L1/L2) and center support (P) and not top (K).

4

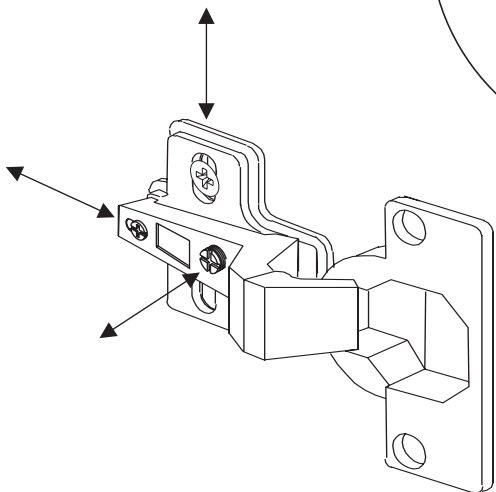
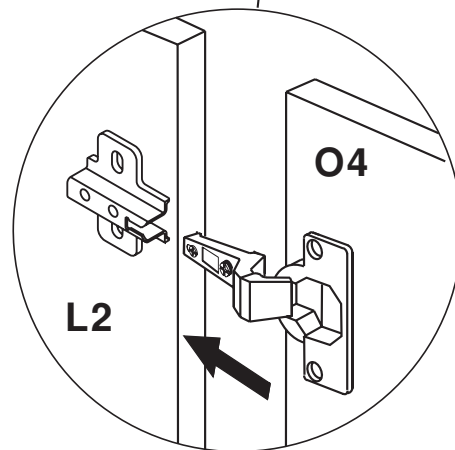
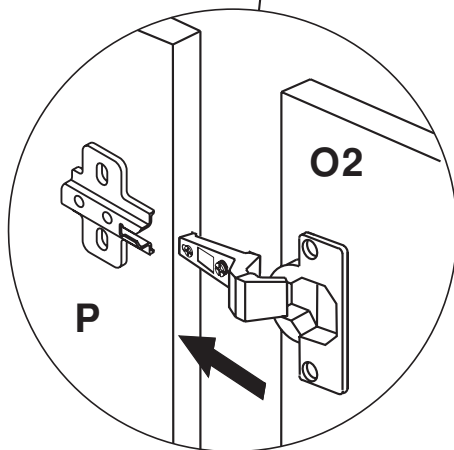
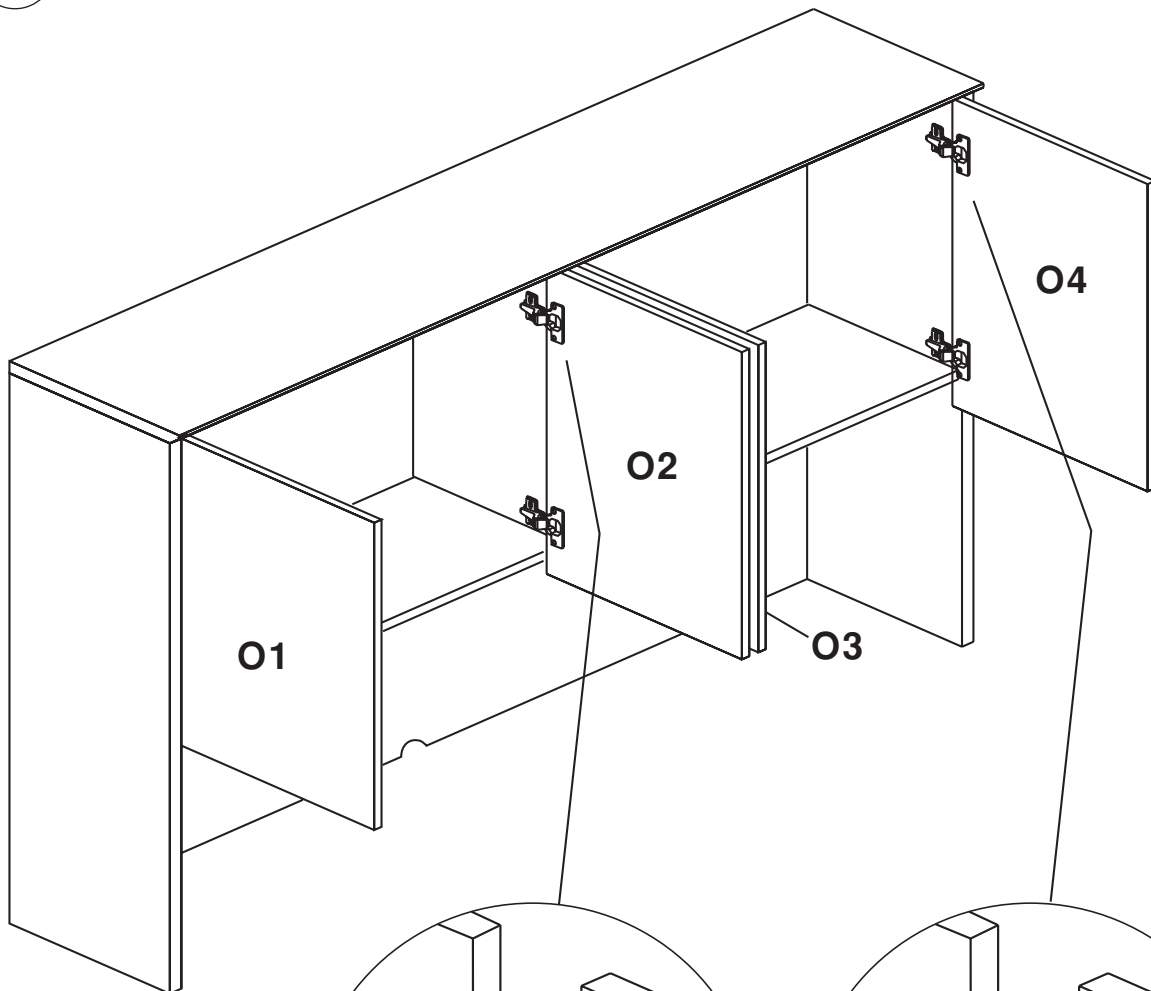

Note: Adjust doors alignment as necessary by using the adjustment screws on the hinges.

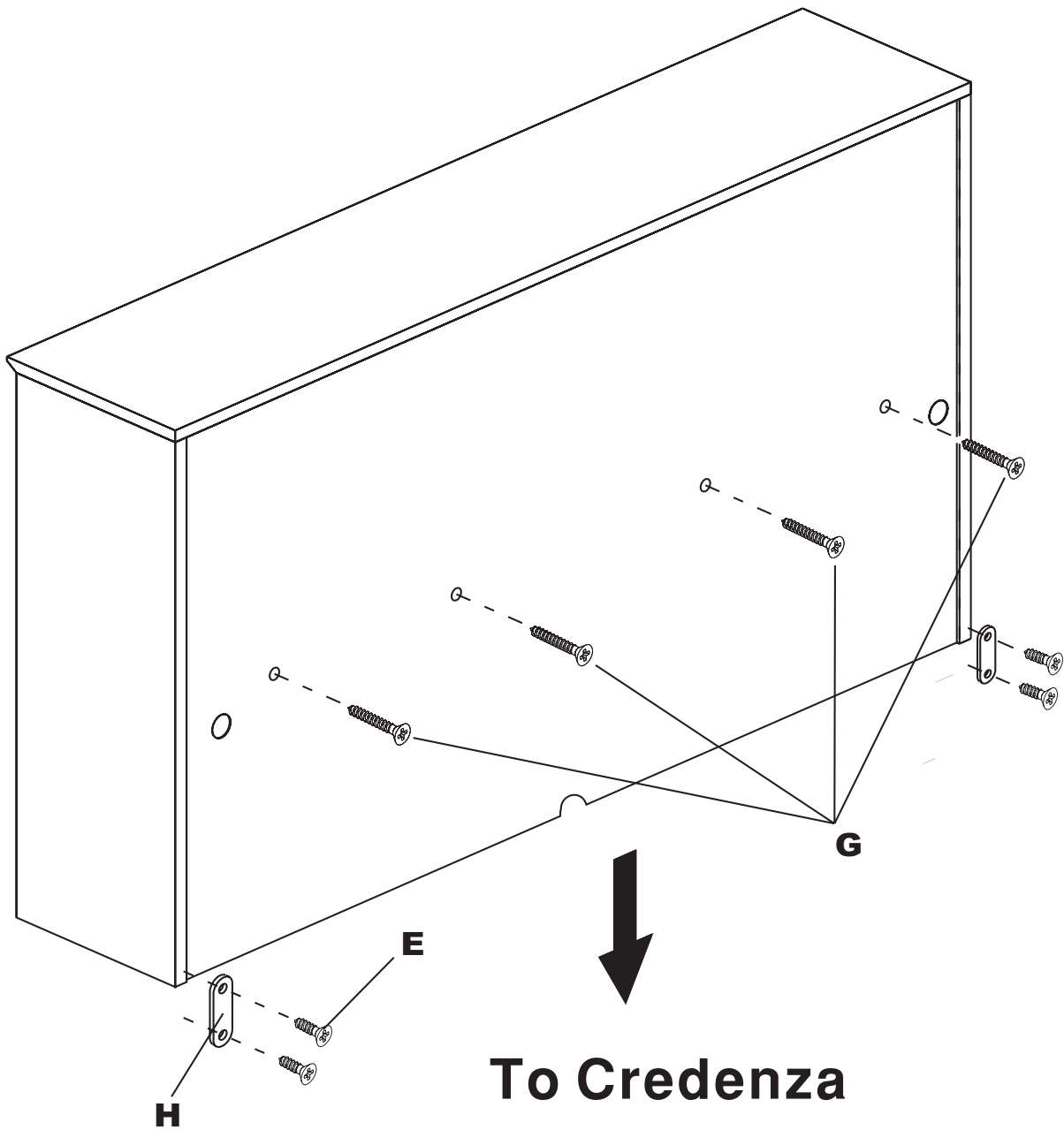

5

5

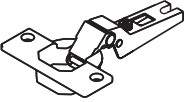
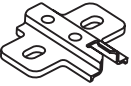
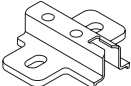

6

Pre-Assembled Replacement Part List

Replacement #	Part	Qty.
REALS051*	 Hinge-Raised Arm	1
REALS013P*	 Hinge Plate-Short	1
REALS051P*	 Hinge Plate-Tall	1
REALS018*	 Hinge Screw 4 x 14mm	1
REALS104*	 Grommet 35mm	1

*For Individual Items, Order By Part Number.