

MODEL WC36494C
WC36496



help you?

THE BUSH BUSINESS FURNITURE

difference

- QUALITY
- INNOVATION
- SERVICE
- VALUE

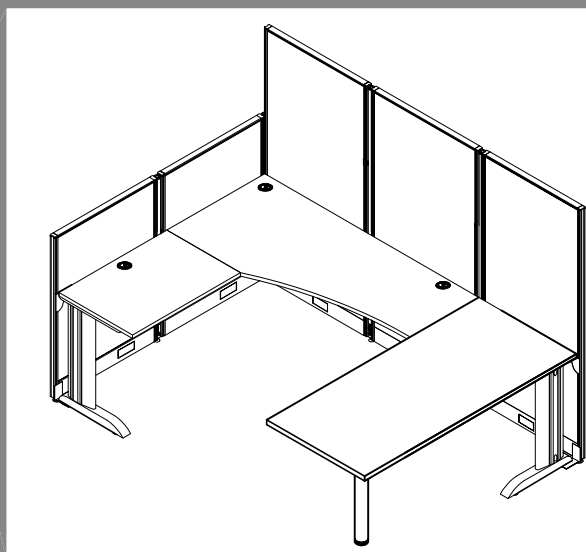

A158093

Bush[®]

BUSINESS FURNITURE

Thank you for purchasing this Bush Business Furniture product. We trust that you will be completely satisfied with your product for many years to come. Bush Business Furniture products are backed by a 10-year warranty and crafted with today's styles in mind for the way you live. **Do not return product to store, ccontact us first at 1-800-950-4782.**

Merci d'avoir acheté ce produit Bush Business Furniture. Nous sommes sûr que vous serez complètement satisfait de votre meuble pendant de nombreuses années. Les produits Bush Business Furniture sont garantis pendant 10 ans et sont conçus dans les styles actuels tout en gardant à l'esprit votre façon de travailler. **Ne renvoyez pas le produit au magasin, contactez-nous d'abord au 1-800-950-4782.**

Gracias por comprar este producto de Bush Business Furniture. Confiamos que usted estará completamente satisfecho con su mueble por muchos años. Los productos de Bush Business Furniture tienen 10 años de garantía y son diseñados con los estilos de hoy en mente para la manera que usted vive. **No devuelva el producto a la tienda, primero comuníquese con nosotros al 1-800-950-4782.**

10 Year
COMMERCIAL
WARRANTY



M - F 8:30 a.m. - 9:30 p.m. EST

Sat. 9 a.m. - 5:30 p.m. EST

(Except Holidays)

Consumer Service Department

1111 Allen Street

Jamestown, NY 14702

ConsumerService@BushIndustries.com

1-800-950-4782 USA/CANADA

001-800-950-4782 MEXICO

Se habla español

10Year
COMMERCIAL
WARRANTY

www.bushbusinessfurniture.com

IT'S AS EASY AS 1,2,3

Assembly tips:

1. Read the instructions and become familiar with the parts.
2. Ensure this carton contains all parts, fasteners and hardware.
3. To protect floors, assemble the furniture on the carton.
4. An assistant may be helpful.
5. Use of power tools is not recommended.

Conseils d'assemblage:

1. Lisez les instructions et familiarisez-vous avec les pièces.
2. Assurez-vous que le carton contient toutes les pièces, toutes les pièces de fixation et toute la quincaillerie.
3. Pour protéger vos sols, assemblez le meuble sur le carton.
4. Il peut être utile de vous faire aider.
5. L'utilisation d'outils électriques n'est pas recommandée.

Consejos de Ensamblaje:

1. Lea las instrucciones y familiarícese con las partes.
2. Asegúrese de que esta caja contenga todas las piezas, los sujetadores y el equipo.
3. Para proteger el piso, ensamble el mueble en el carton.
4. Un asistente puede serle útil.
5. El uso de herramientas eléctricas no se recomienda.

CONSUMER SERVICE YOU CAN DEPEND ON

Questions? Operators are standing by at our TOLL-FREE help line to assist you with assembly; and, if necessary, to quickly replace damaged/missing parts. Assistance is available 6 days a week. Simply have your store receipt, instruction manual, and part number/description ready when you call our TOLL -FREE help line. It's that easy.

UN SERVICE CLIENTELE SUR LEQUEL VOUS POUVEZ COMPTER

Des questions? Des opérateurs sont prêts sur notre ligne d'assistance GRATUITE pour vous aider à l'assemblage et, si nécessaire, remplacer rapidement les pièces endommagées/manquantes. L'assistance est disponible 6 jours par semaine. Ayez simplement votre reçu de magasin, votre manuel d'instruction et le numéro de pièces/description à votre disposition lorsque vous appelez notre ligne d'assistance GRATUITE. C'est aussi simple que ça.

SERVICIO AL CONSUMIDOR CON EL QUE PUEDE CONTAR

¿Preguntas? Los operadores están listos para ayudarlo con el ensamblaje a través de una línea de ayuda GRATUITA, y en caso de ser necesario, reemplazar de inmediato las piezas dañadas o faltantes. La asistencia está disponible los 6 días de la semana. Solamente tenga listos su recibo de compra, manual de indicaciones y número/descripción de la pieza al momento de llamarnos a la línea de ayuda GRATUITA, Es así de sencillo.

IMPORTANT SAFETY INFORMATION



WARNING

Please assemble in final location, do not move after assembly. Unit must be disassembled before relocating, do not move while assembled. Moving the assembled unit could cause instability, product collapse and/or serious injury.

Por favor reúnase en la posición final, no mueva la unidad después de ensamblaje. La unidad debe ser desmontada antes del traslado, no mueva la unidad ensamblada. El movimiento de la unidad ensamblada podría causar la inestabilidad, el desplome del producto y/o heridas graves.

Veillez l'assembler dans l'endroit final, ne se déplacent pas après l'assemblage. L'unité doit être démontée avant le déplacement, ne le déplacement pas tandis qu'elle est assemblée. Le déplacement de l'unité assemblée peut causer l'instabilité, l'effondrement de produit et/ou les dommages sérieux.

EXPLODED VIEW

WC36494C

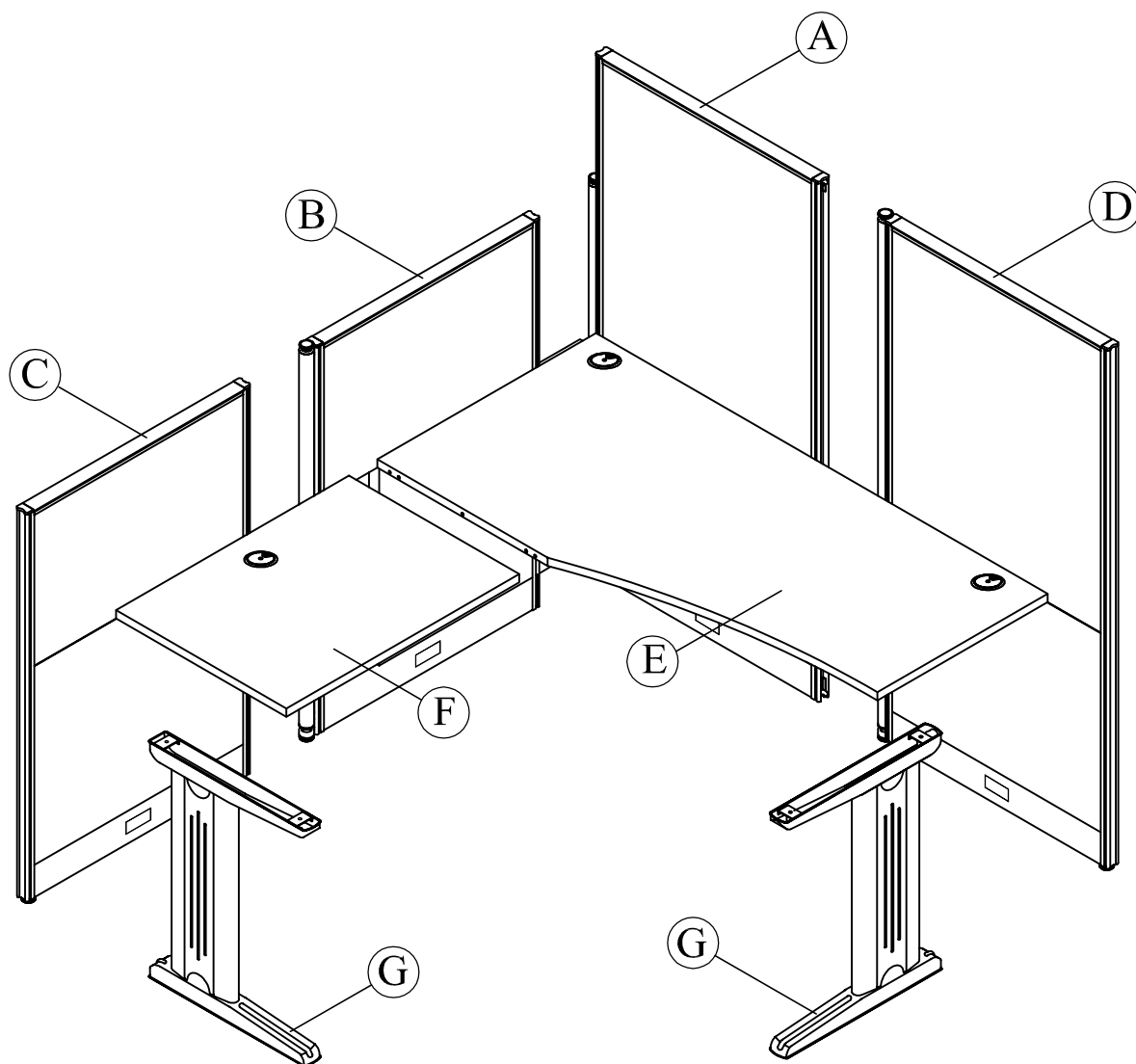
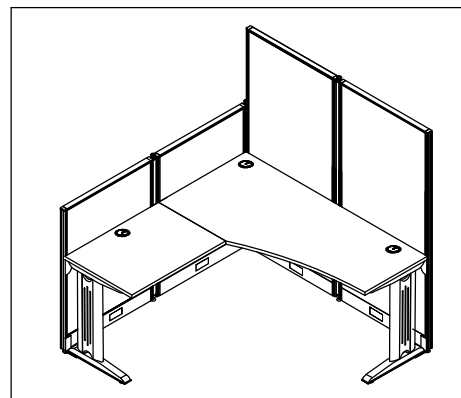

- A [1] S146909
- B [1] S146910
- C [1] S146911
- D [1] S153003
- E [1] S148743
- F [1] S148744
- G [2] H150931





? 1 - 800 - 950 - 4782

A158093

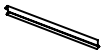
Pre-assembled Components

- H146902  [2]
- H146903  [1]
- H153719  [8]
- H153508  [1]

- H146905  [5]
- H146906  [3]
- H147237  [2]

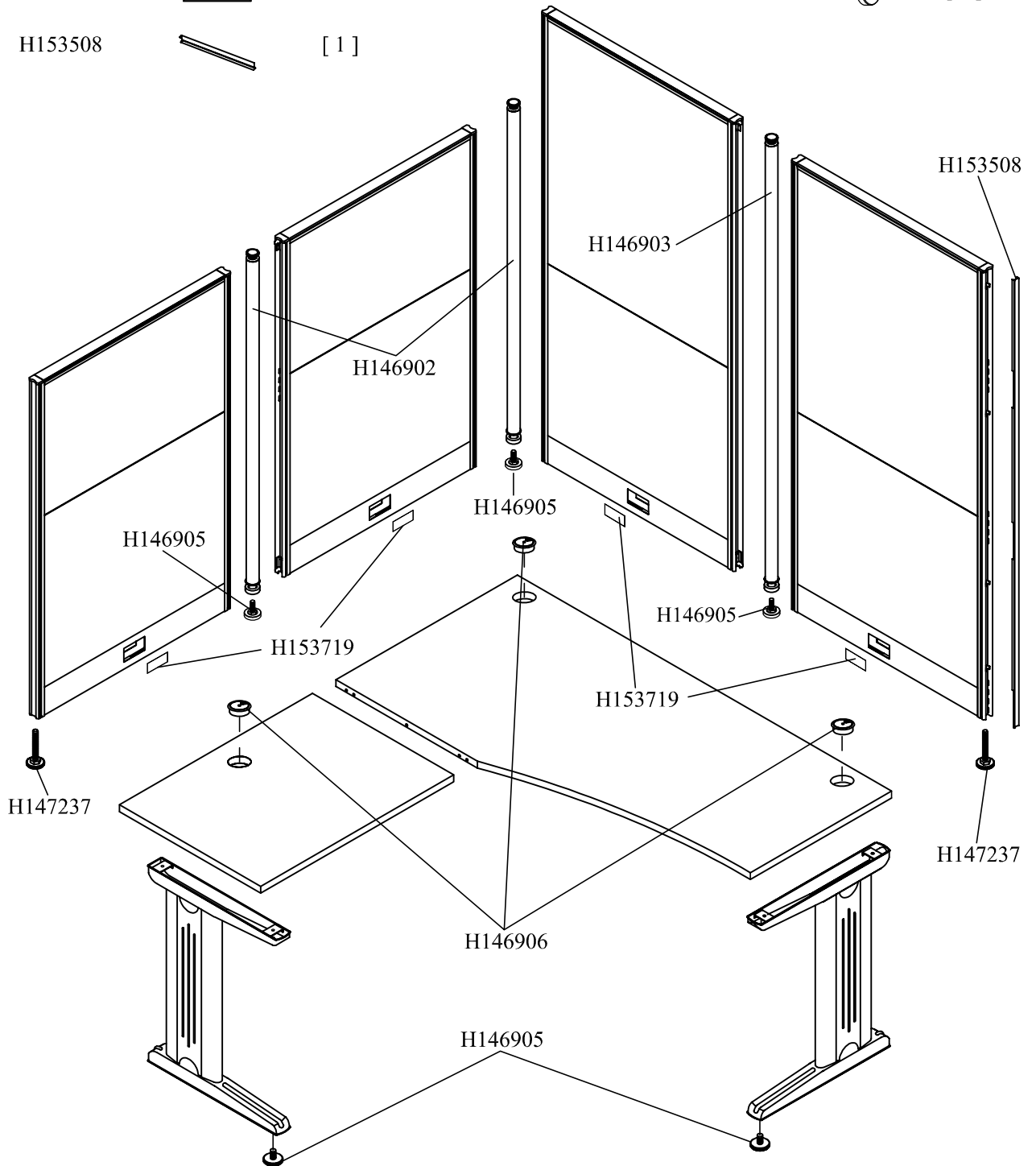

? 1 - 800 - 950 - 4782

A158093

FASTENER LIST

WC36494C

H146892

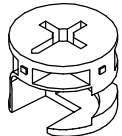

Quantity
6

H146893

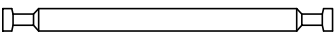

Quantity
3

H148749

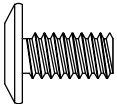

Quantity
17

M6x12mm

H148756

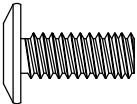

Quantity
4

M6x15mm

H147242



Quantity
2

8 x 40mm

H146895

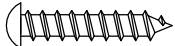

Quantity
3

#8x3/4"

HARDWARE LIST

WC36494C

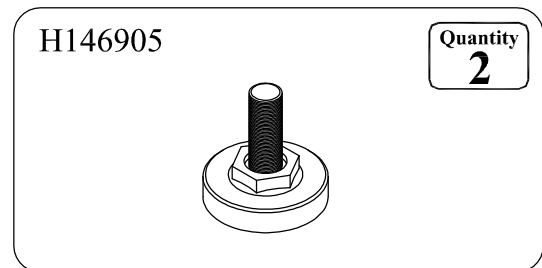
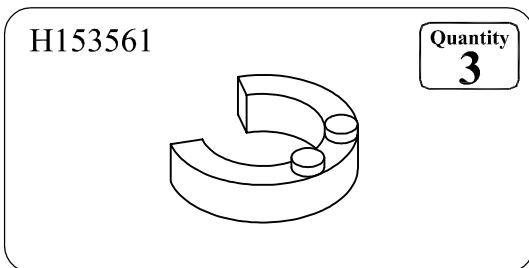
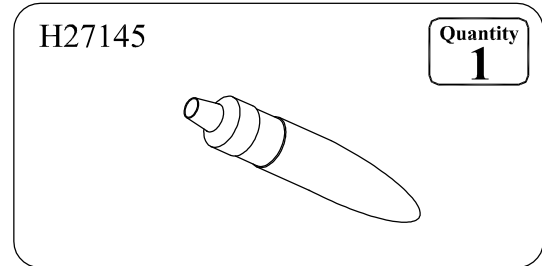
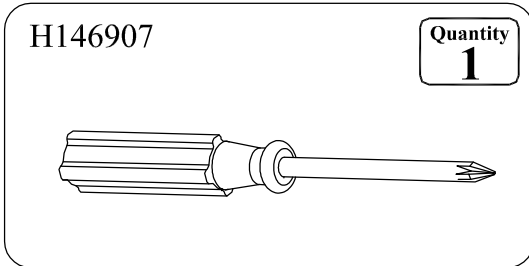

EXPLODED VIEW

WC36496

H [1] S153013

I [1] S158608

J [1] S158609

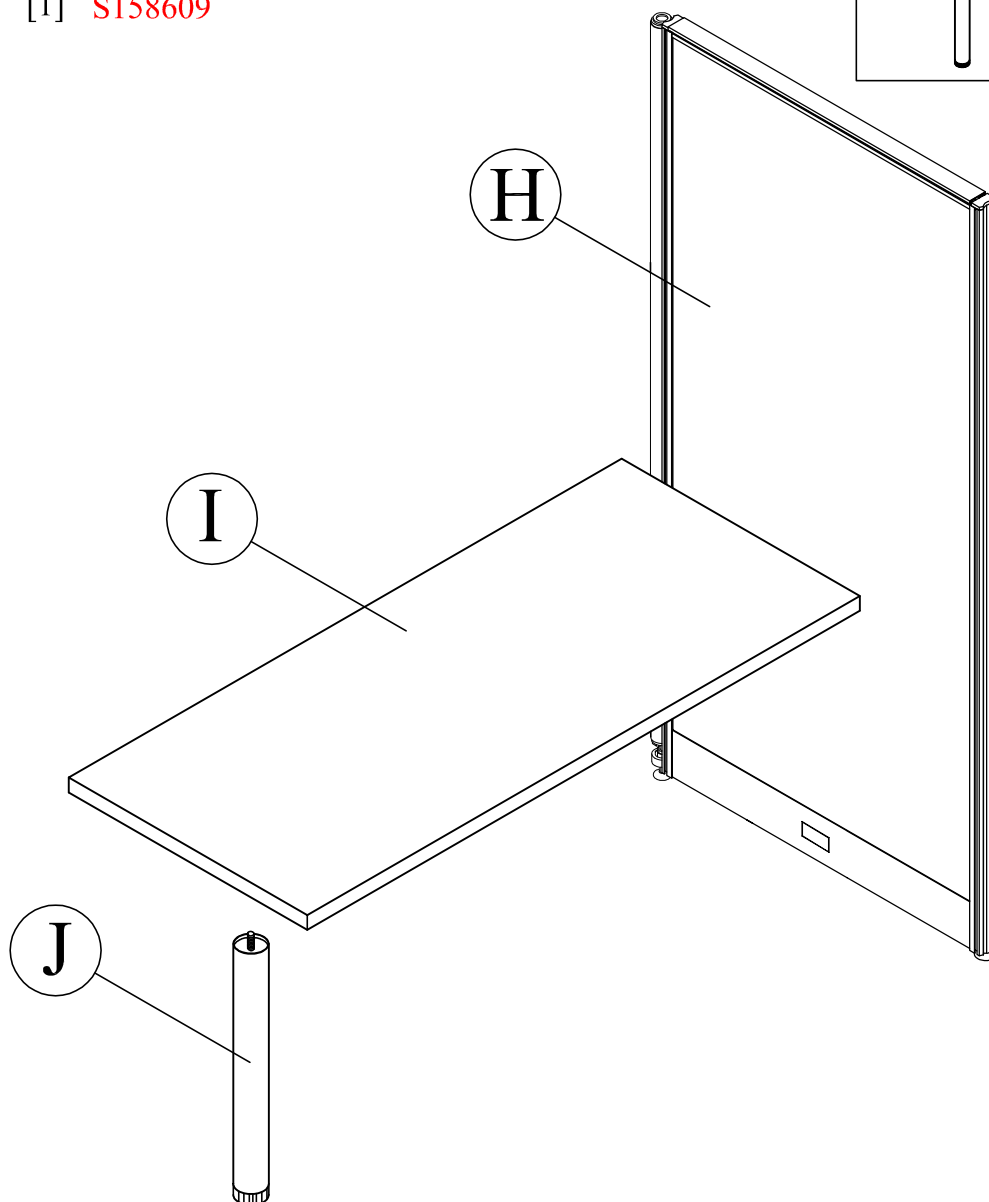
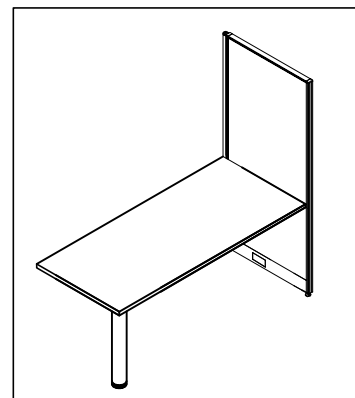

? 1 - 800 - 950 - 4782

A158093

Pre-assembled Components

H153719  [2]

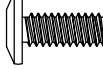
H153511  [8]

H147237  [1]

H153559  [1]

H146905  [1]

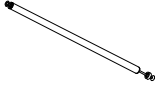
H146903  [1]

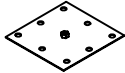
H153558  [1]

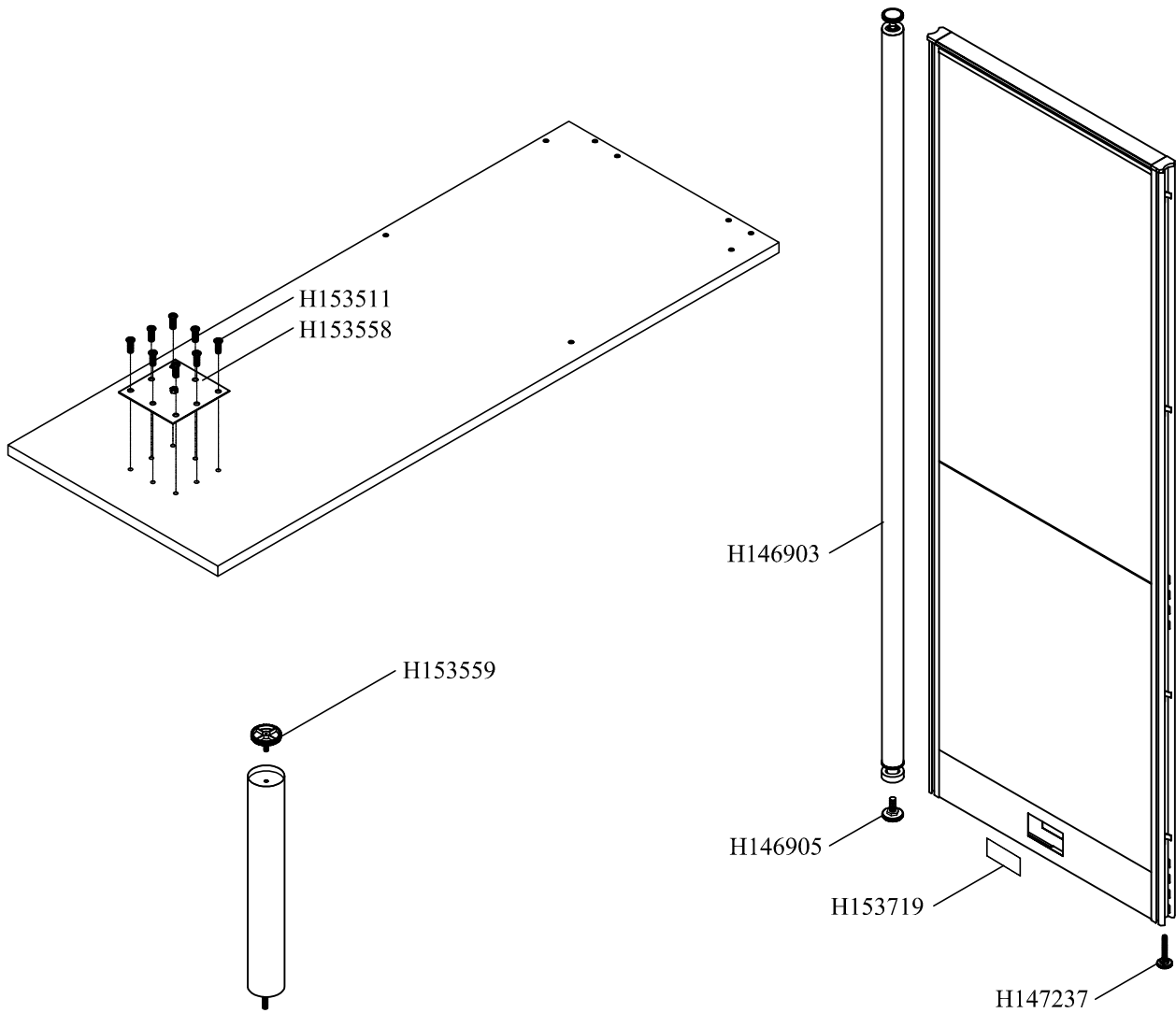

? 1 - 800 - 950 - 4782

A158093

FASTENER LIST

WC36496

H153023

Quantity
4



#6x3/8"

H148749

Quantity
4

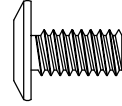

M6x12mm

H148756

Quantity
4

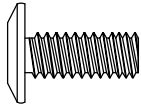

M6x15mm

HARDWARE LIST

WC36496

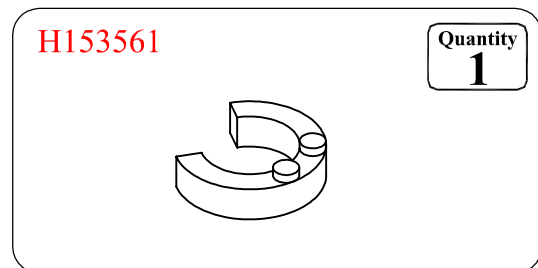
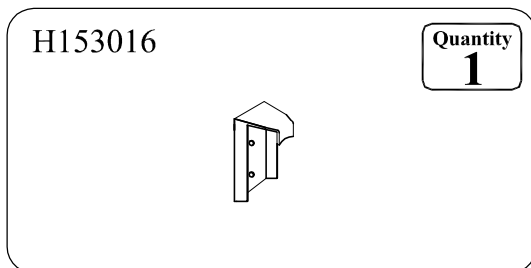
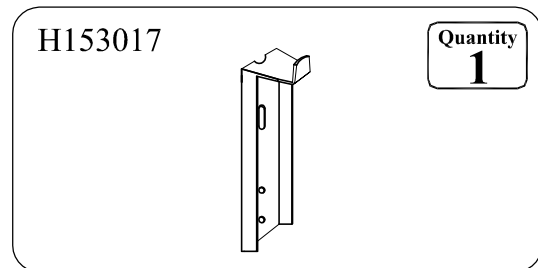
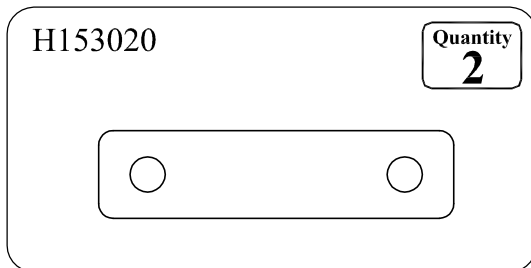
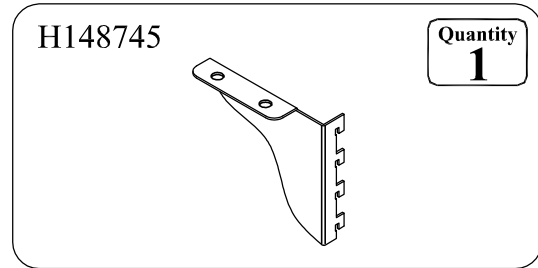
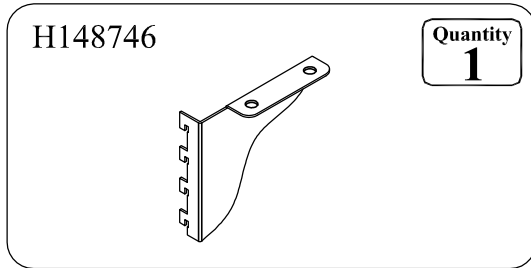

Step 1

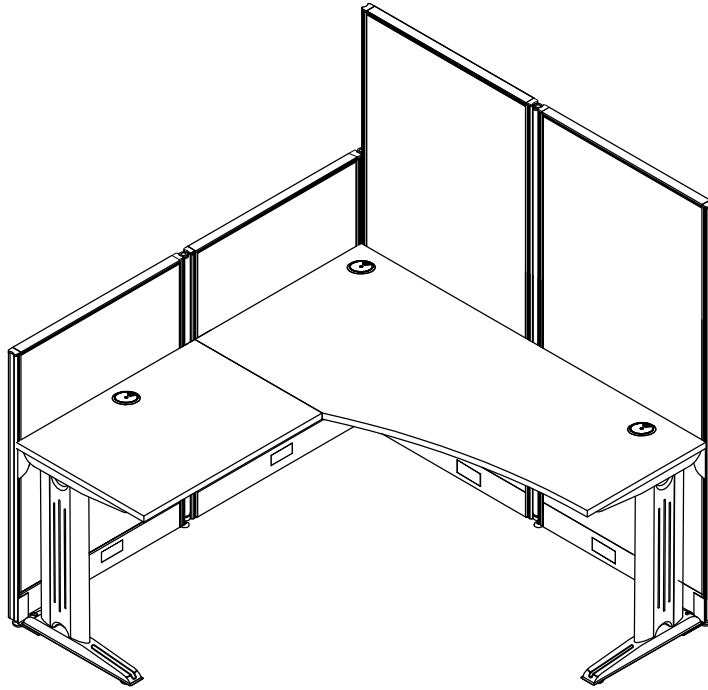

WC36494C

Please proceed to step 2

Proceda al paso 2

Allez à l'étape 2

WC36494C

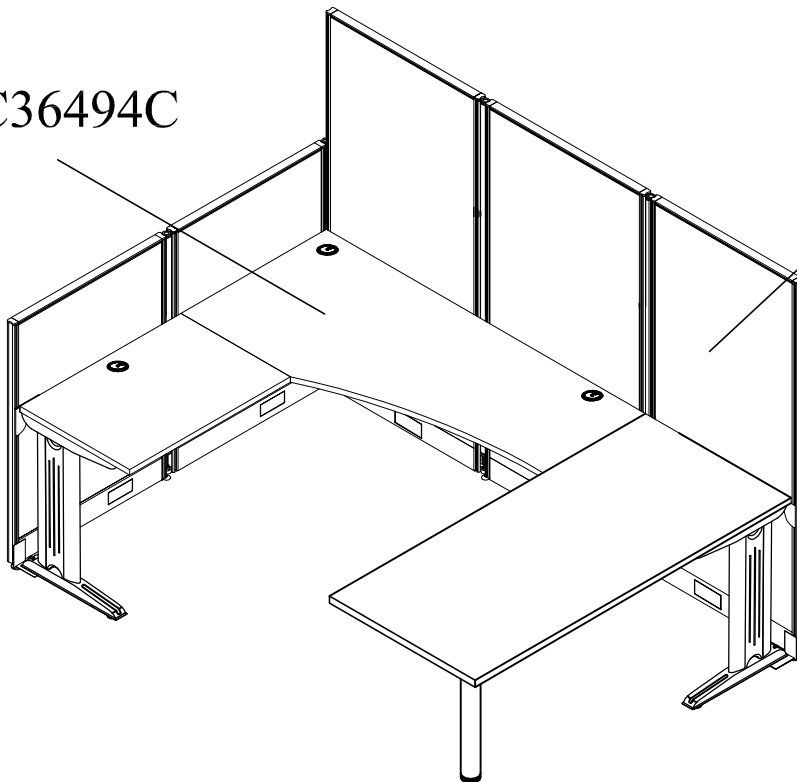

Please proceed to step 16

Proceda al paso 16

Allez à l'étape 16

WC36496

? 1 - 800 - 950 - 4782

A158093

Step 2

An assistant is required.
Es necesario un ayudante.
Un assistant est nécessaire.

Remove bag first
Enlevez le sac en premier
Retire La bolsa primero

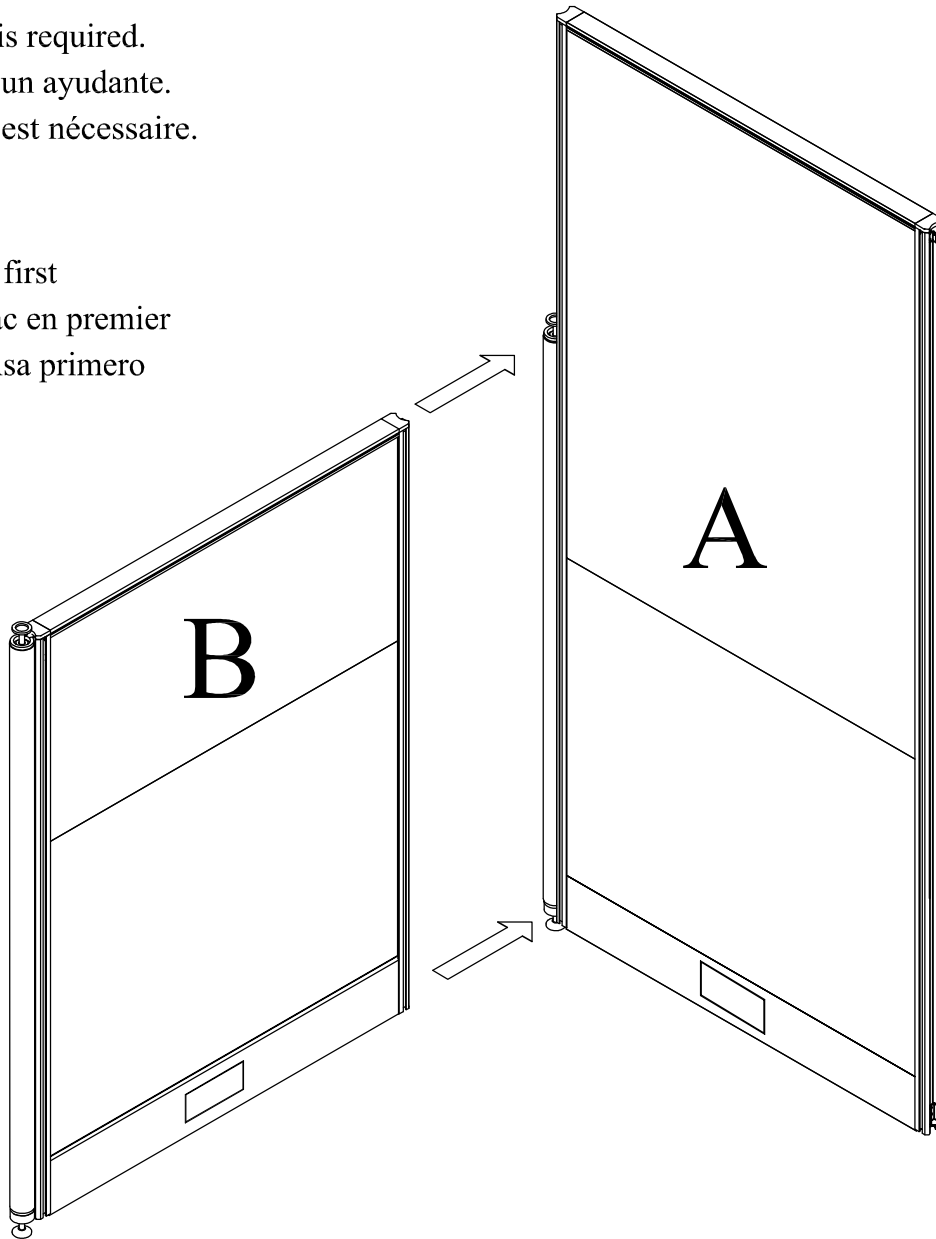

1 Loosen
aflojar
desserrez

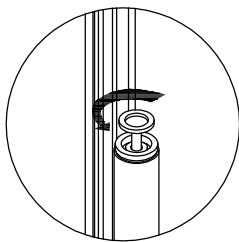

2 Assemble
ensamblar
réunissez

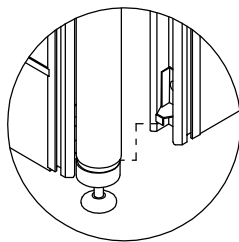

3 Assemble
ensamblar
réunissez

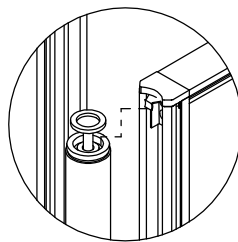

4 Tighten
Apretar
serrez

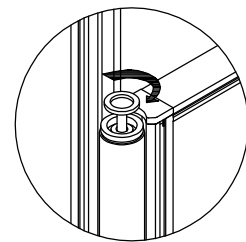

? 1 - 800 - 950 - 4782

A158093

Step 3

H153561



[1]

An assistant is required.
Es necesario un ayudante.
Un assistant est nécessaire.

Remove bag first
Enlevez le sac en premier
Retire La bolsa primero

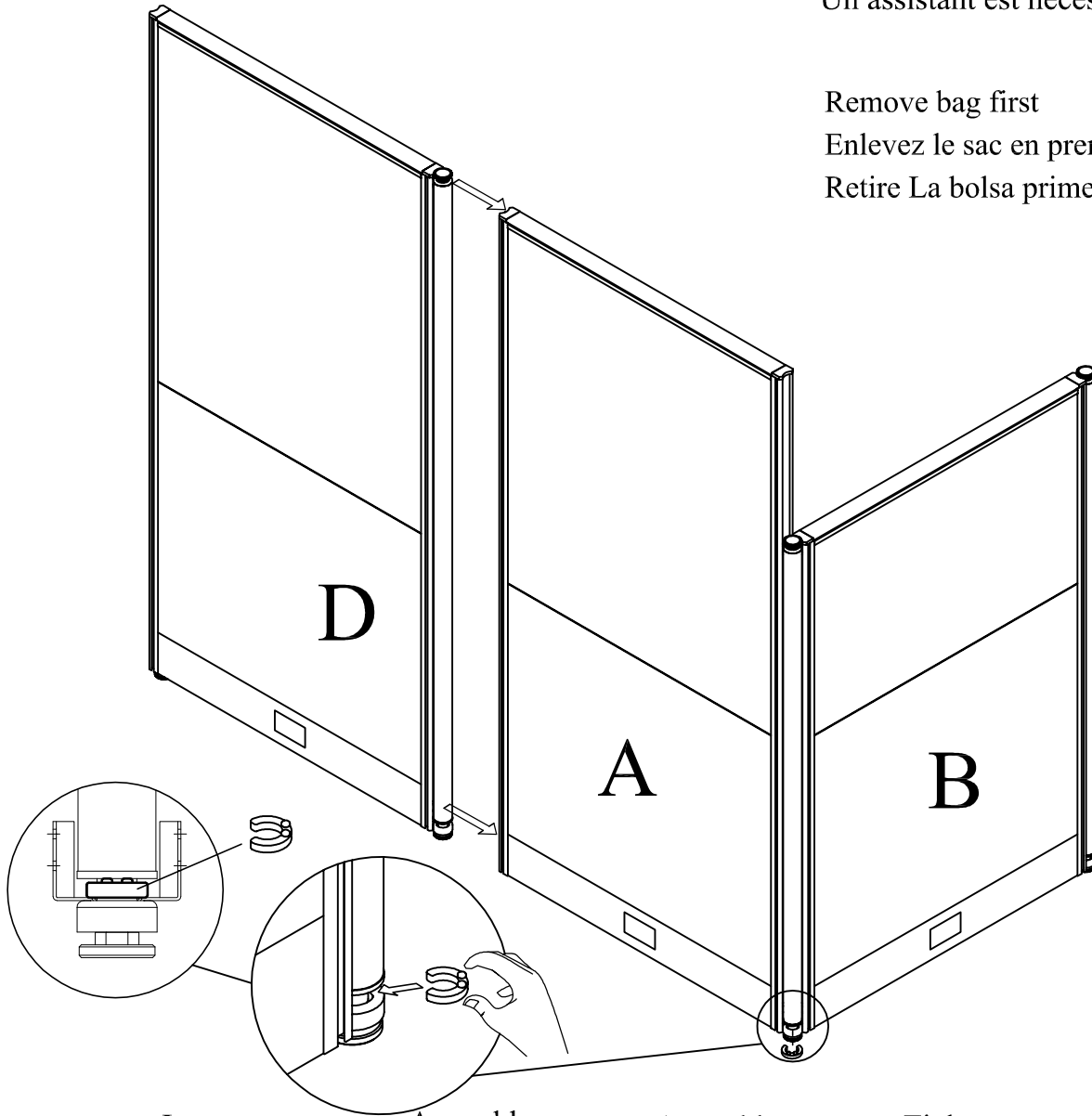

1 Loosen
aflojar
desserrez

2 Assemble
ensamblar
réunissez

3 Assemble
ensamblar
réunissez

4 Tighten
Apretar
serrez

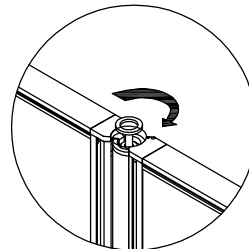
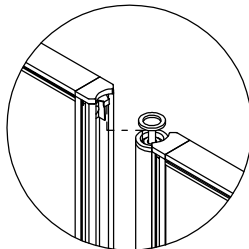
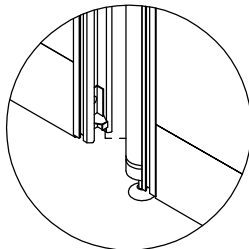
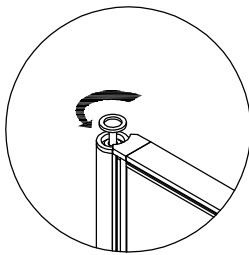

? 1 - 800 - 950 - 4782

A158093

Step 4

Discard carton and packaging material.
Descarte el material de cartón y embalaje.
Jeter le carton et le matériau d'emballage.

H153561



[1]

Open box 2
Abra la caja 2
Ouvrir la boîte 2

An assistant is required.
Es necesario un ayudante.
Un assistant est nécessaire.

Remove bag first
Enlevez le sac en premier
Retire La bolsa primero

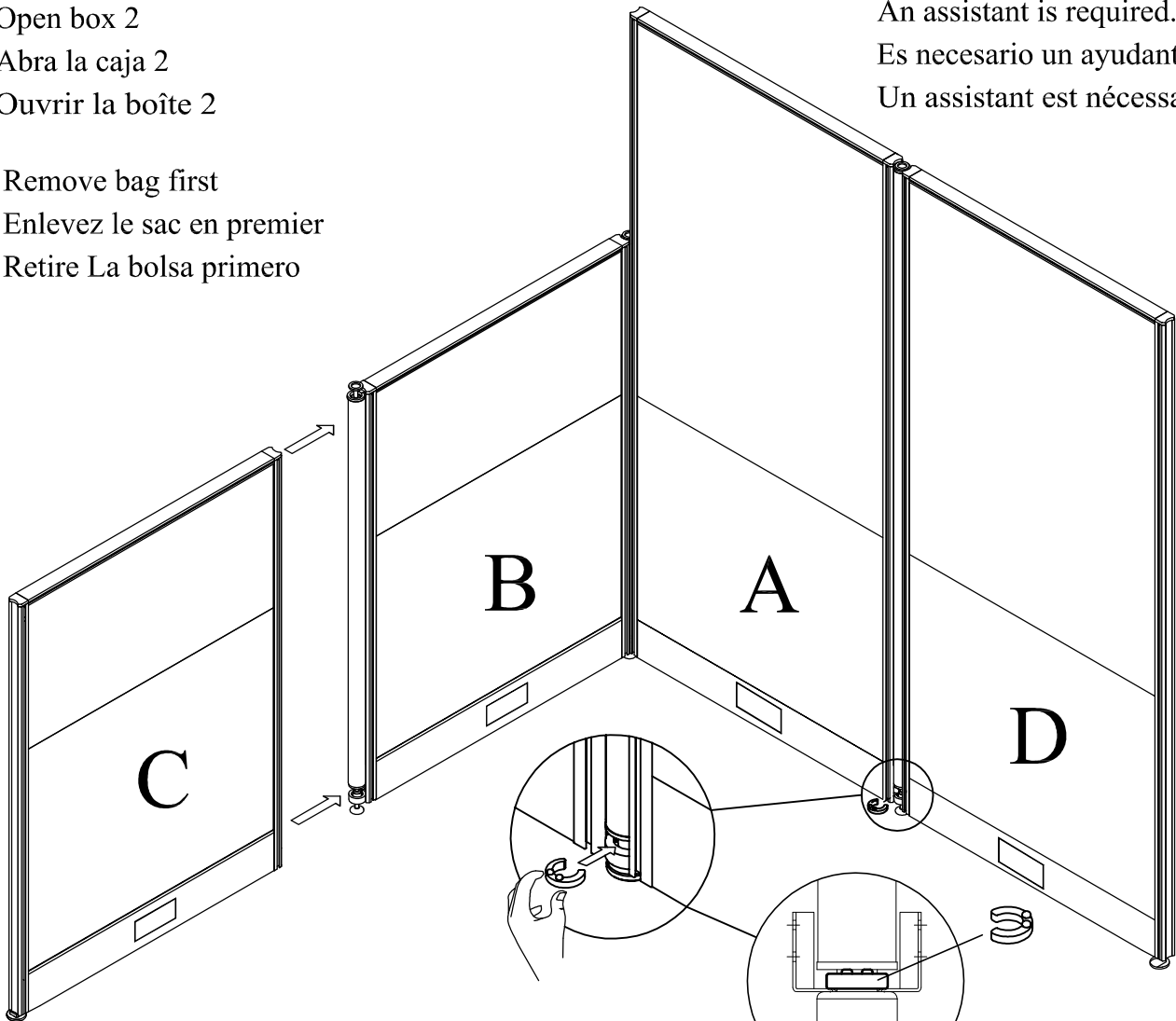

1 Loosen
aflojar
desserrez

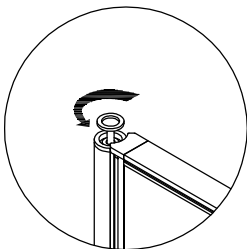

2 Assemble
ensamblar
réunissez

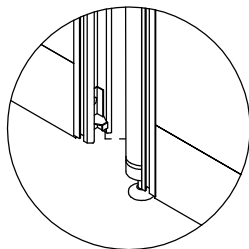

3 Assemble
ensamblar
réunissez

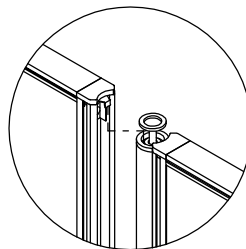

4 Tighten
Apretar
serrez

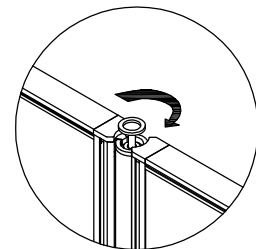

? 1 - 800 - 950 - 4782

A158093

Step 5

H153561



[1]

An assistant is required.
Es necesario un ayudante.
Un assistant est nécessaire.

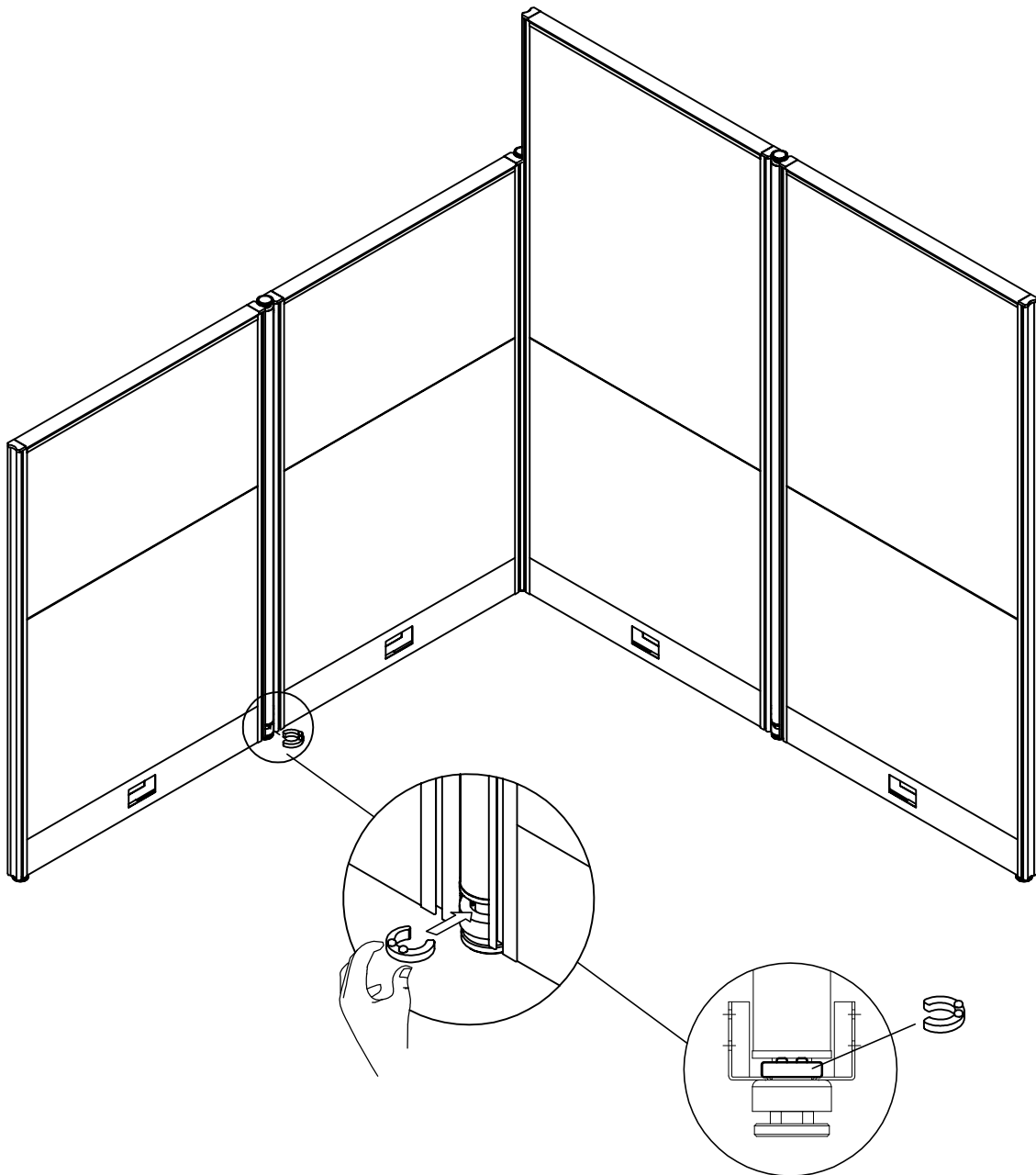

? 1 - 800 - 950 - 4782

A158093

Step 6

- H148746 [2]
- H148745 [2]
- H148747 [1]
- H148748 [1]

An assistant is required.
 Es necesario un ayudante.
 Un assistant est nécessaire.

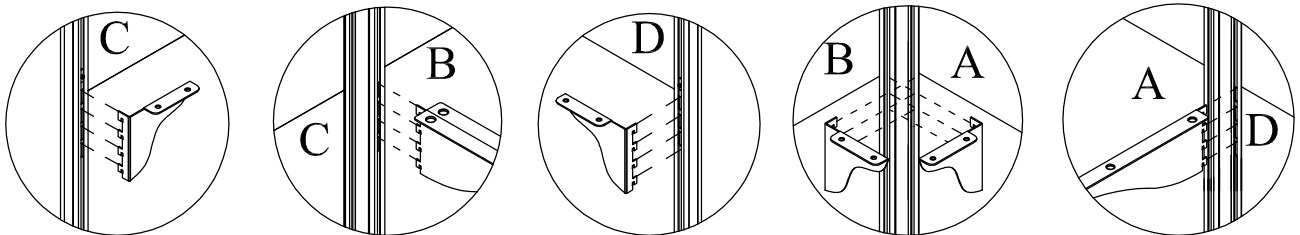
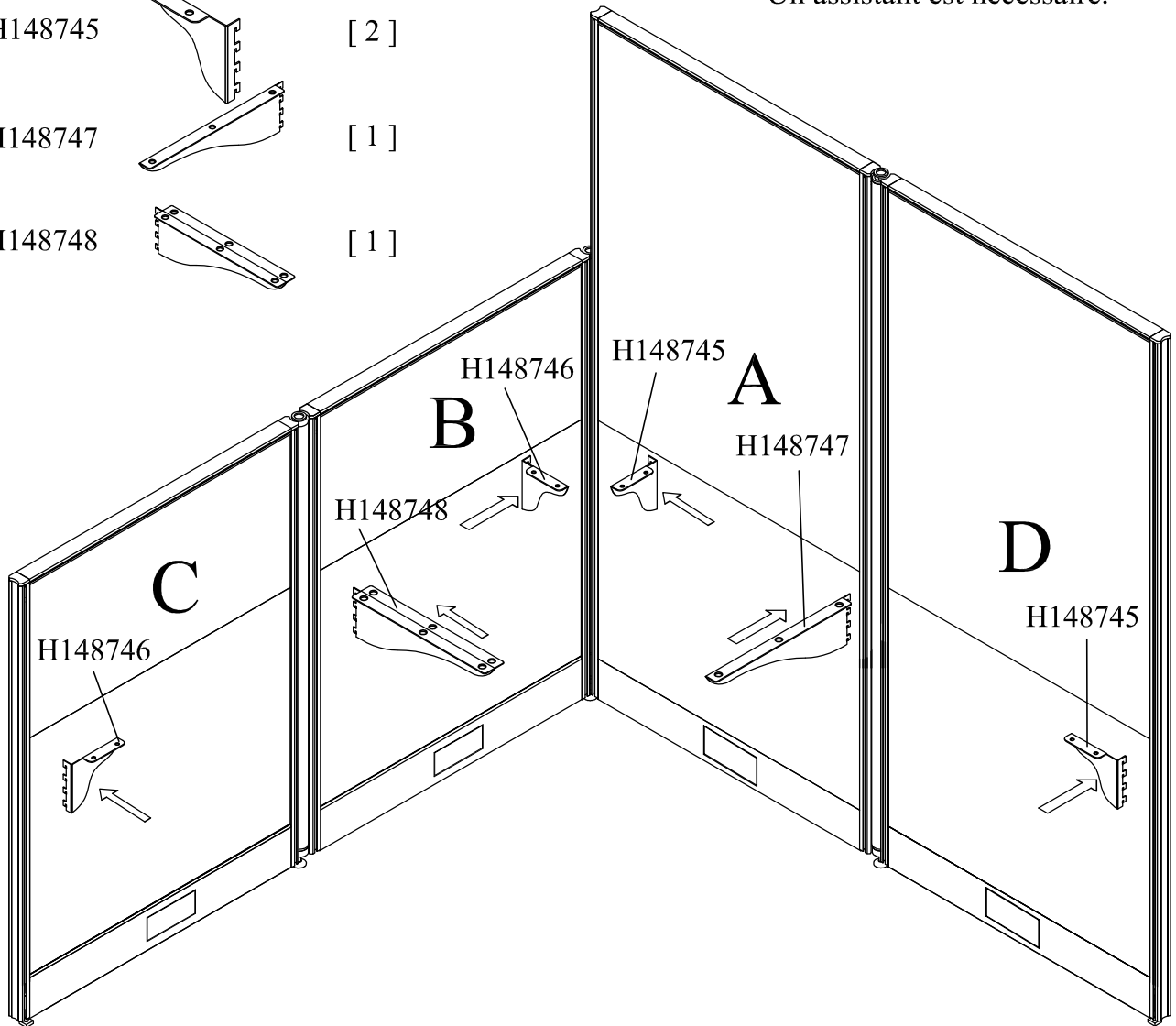



? 1 - 800 - 950 - 4782

A158093

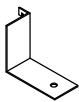
Step 7

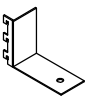
H146899  [1]

H146898  [1]

H146905  [2]

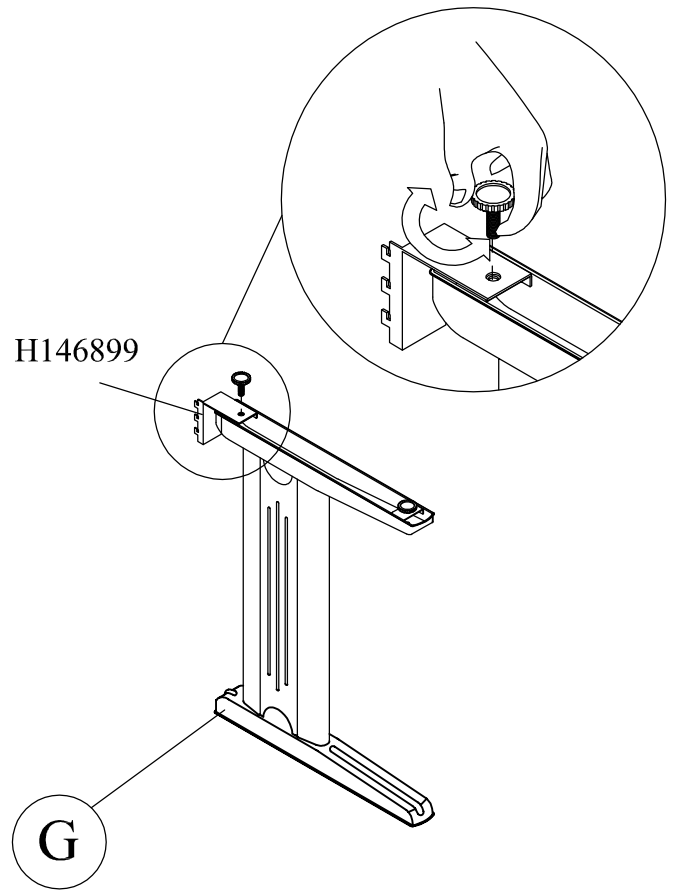
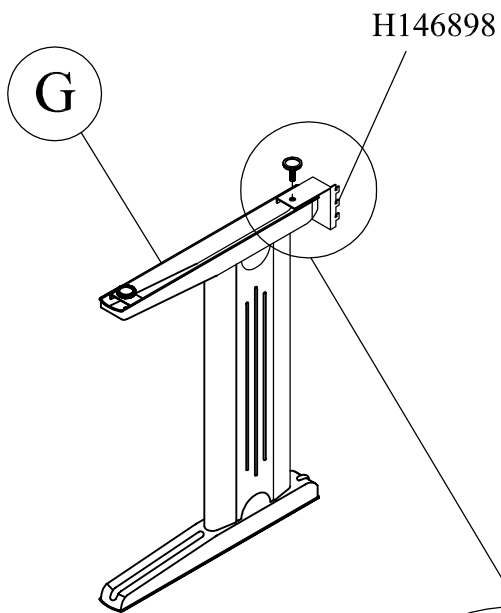

Step 8

Please loosen the screw first, place it just above the bracket, then tighten

Primero afloje el tornillo, colóquelo sobre el soporte, luego apriete

Veillez desserrer la vis d'abord, la placer juste au-dessus du croisillon, puis serrer

H146907

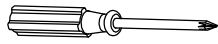



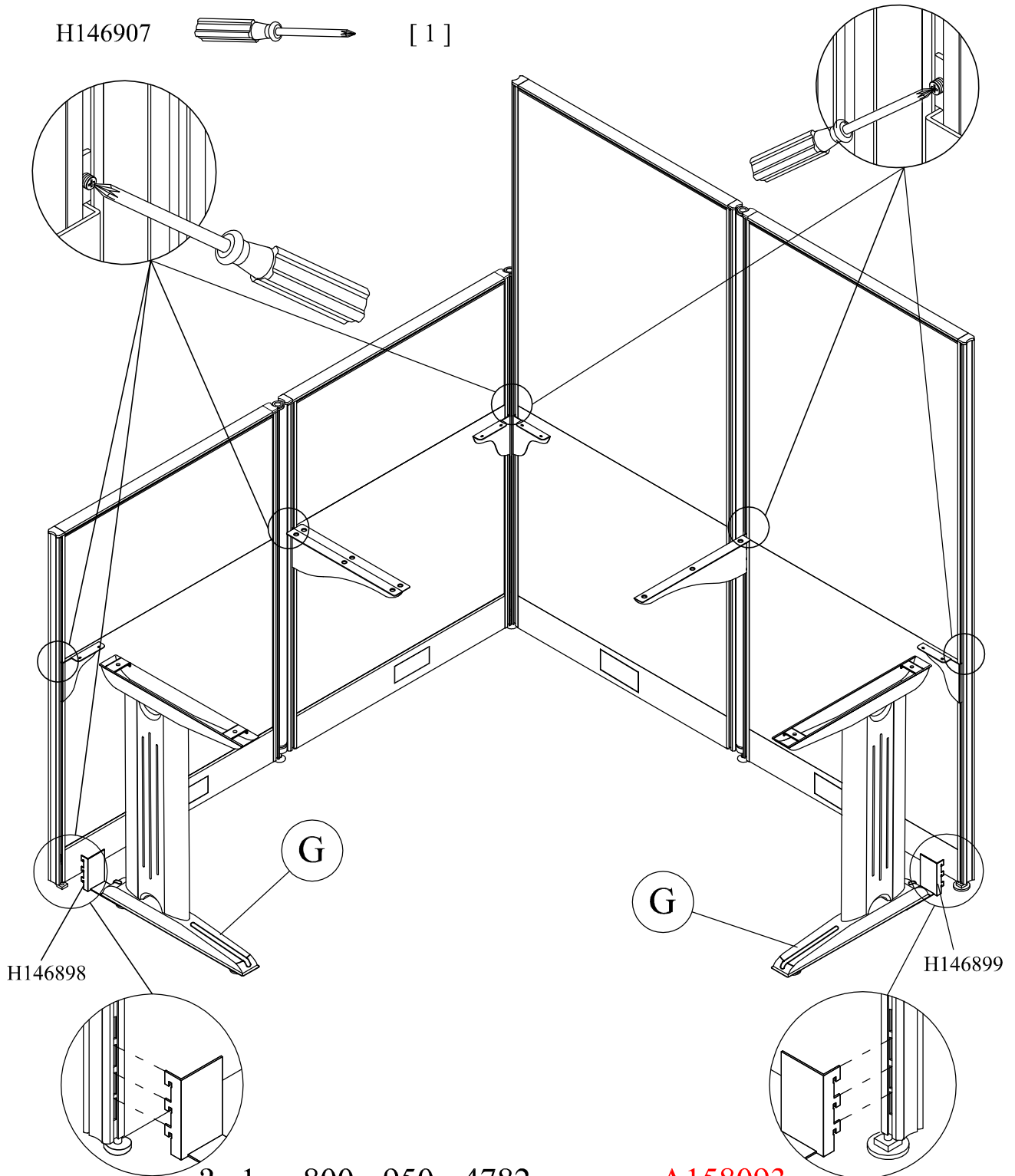



[1]

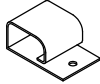

? 1 - 800 - 950 - 4782

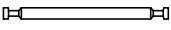
A158093

Step 9

- | | | |
|---------|---|-------|
| H146904 |  | [3] |
| H146895 |  | [3] |
| H146907 |  | [1] |
| H146893 |  | [3] |
| H146892 |  | [3] |
| H27145 |  | [1] |
| H147242 |  | [2] |

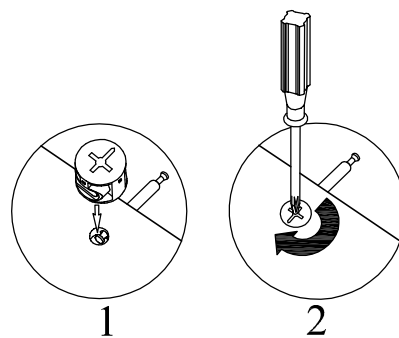
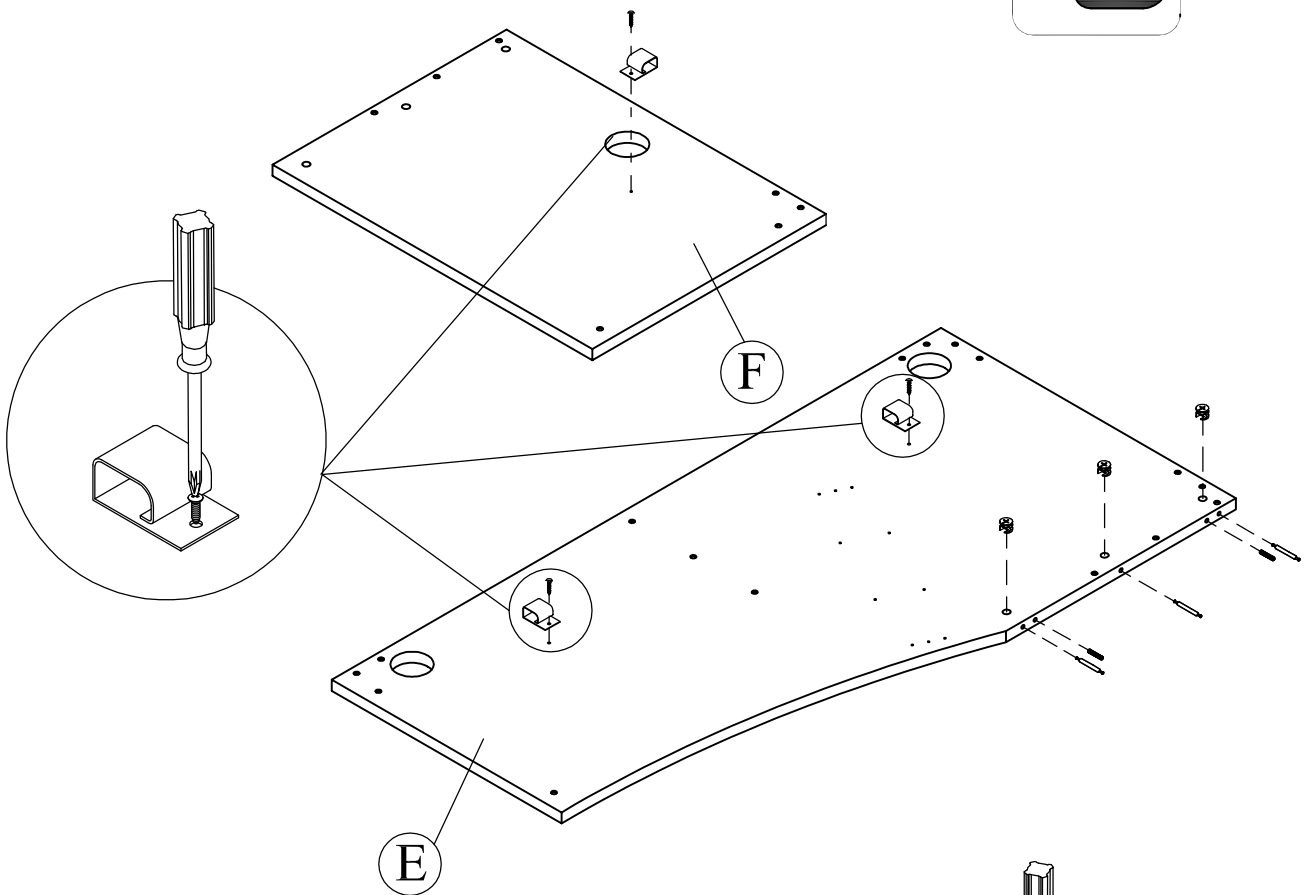
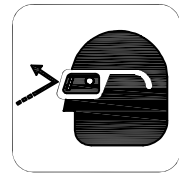
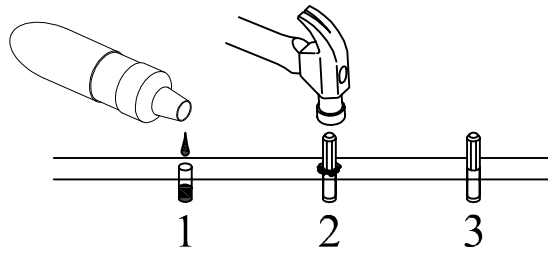

An assistant is required.
 Es necesario un ayudante.
 Un assistant est nécessaire.

? 1 - 800 - 950 - 4782

A158093

Step 10

An assistant is required.

Es necesario un ayudante.

Un assistant est nécessaire.

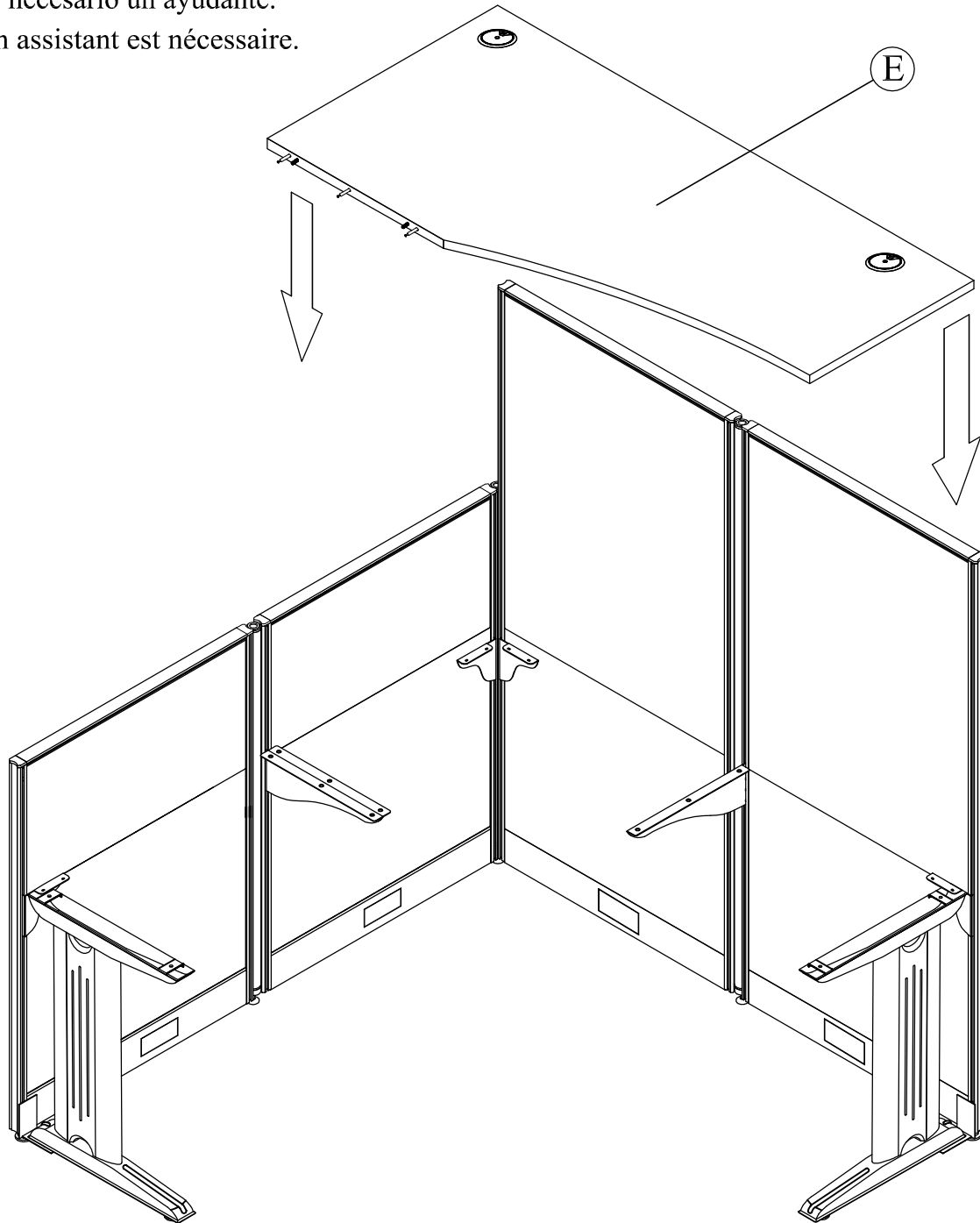

? 1 - 800 - 950 - 4782

A158093

Step 11

An assistant is required.
Es necesario un ayudante.
Un assistant est nécessaire.

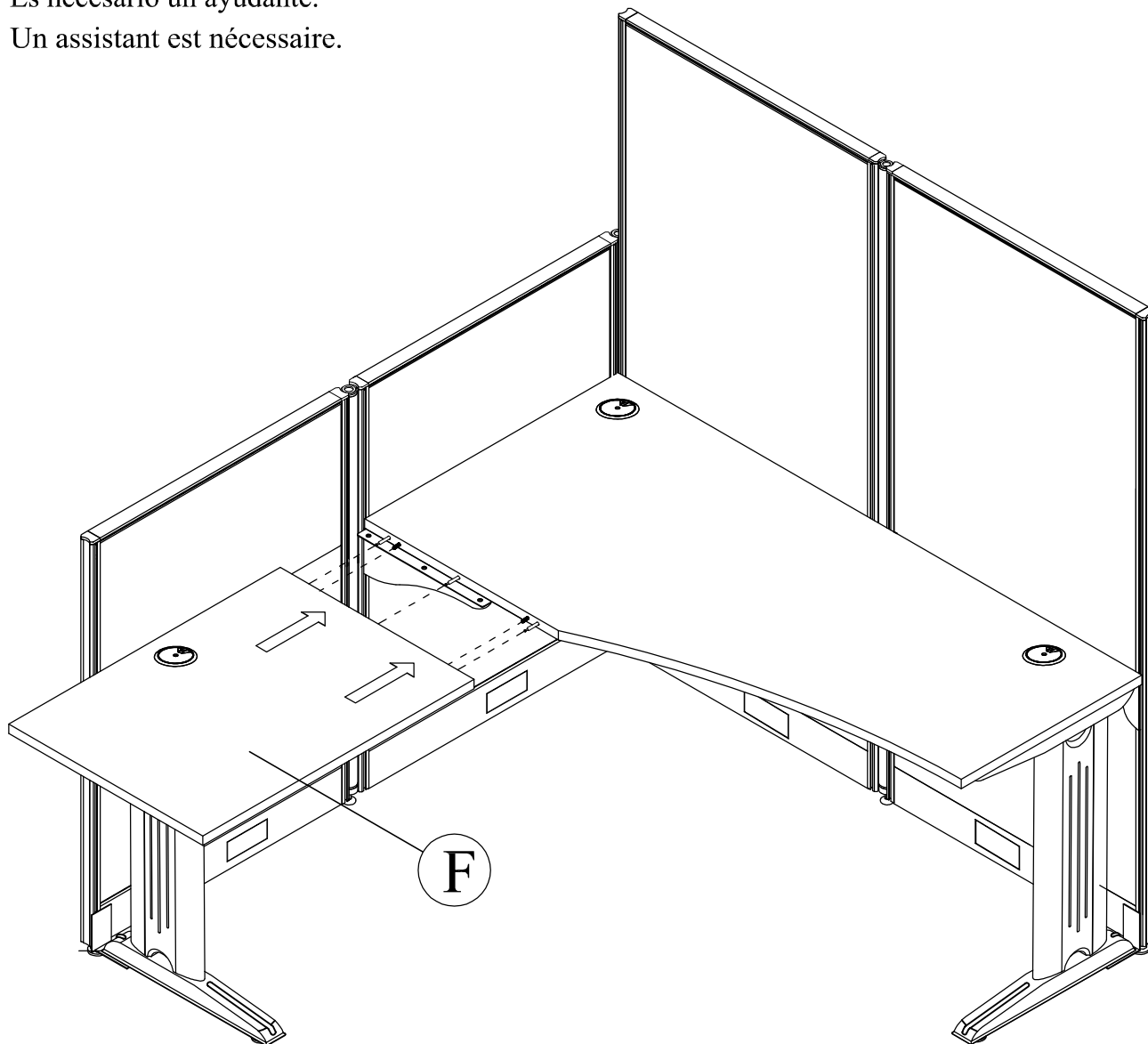

Step 12

H146892  [3]

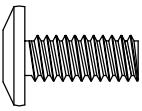
H148756  [4]

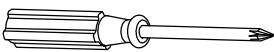
H146907  [1]

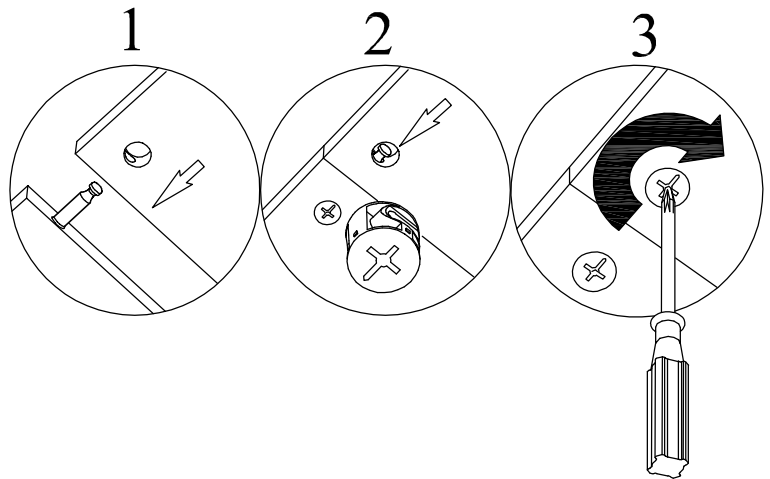
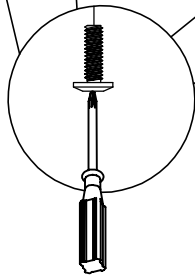
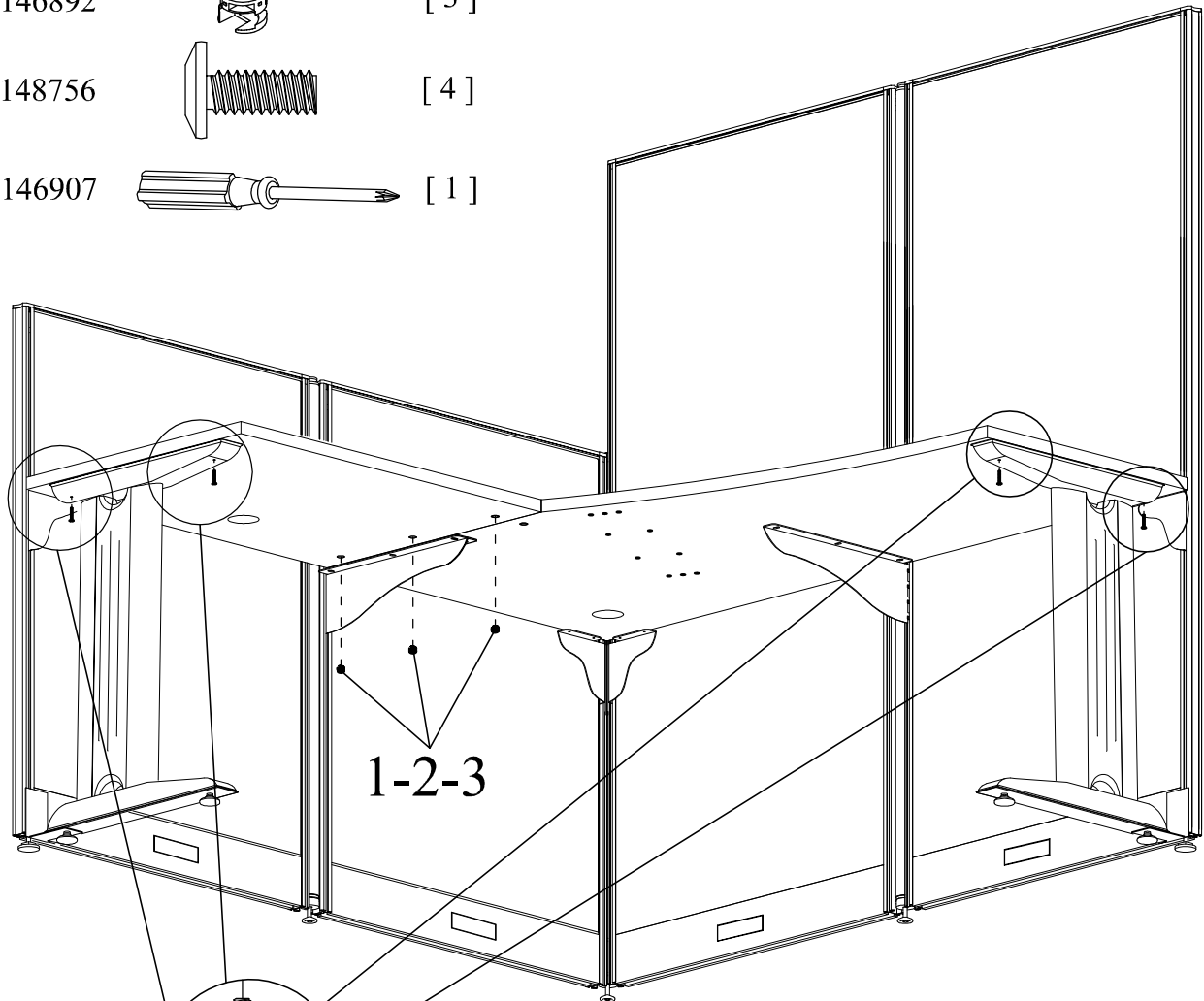

An assistant is required.
Es necesario un ayudante.
Un assistant est nécessaire.

? 1 - 800 - 950 - 4782

A158093

Step 13

H148749

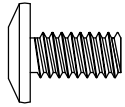

[17]

H146907

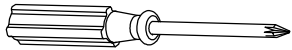

[1]

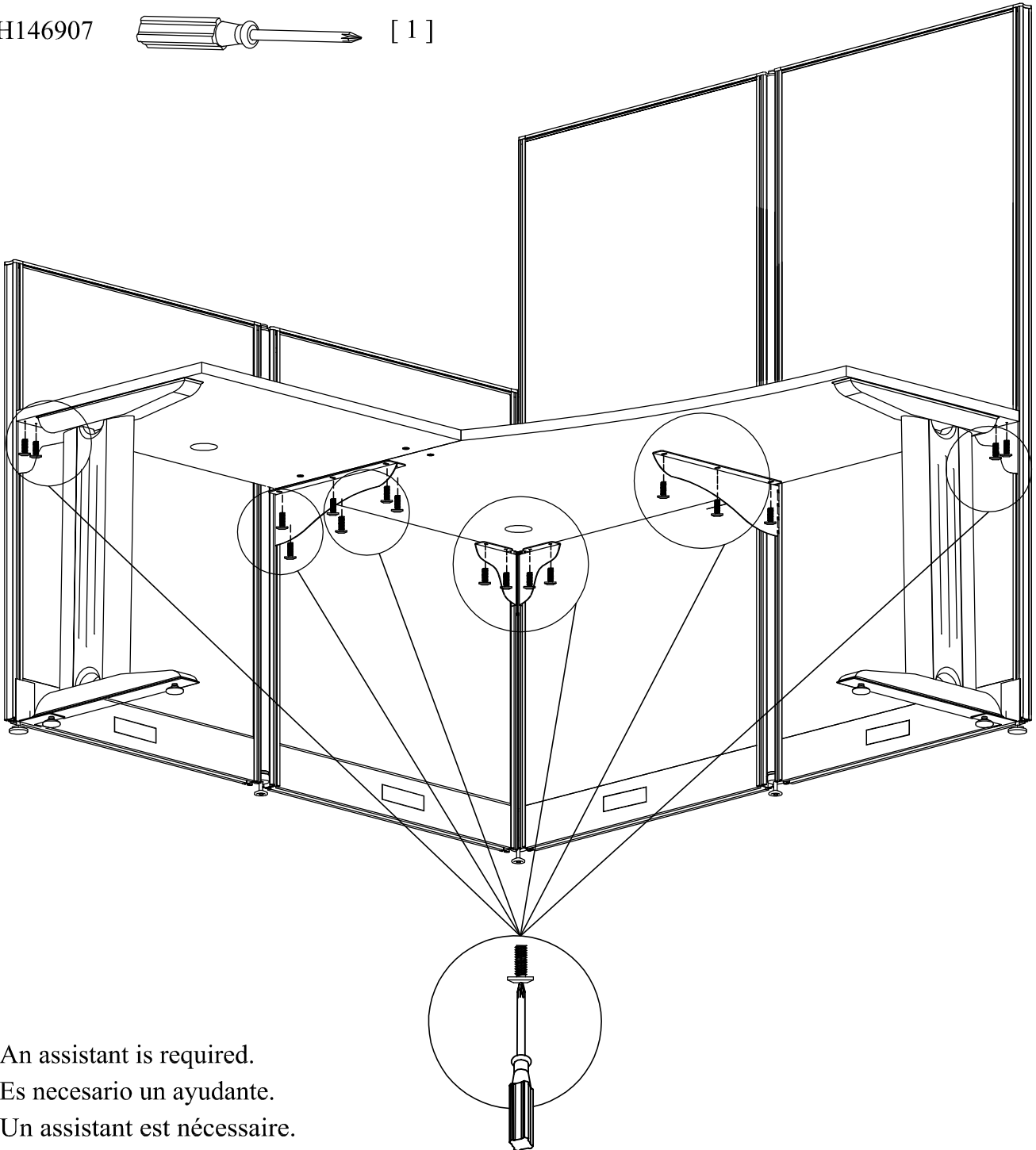

An assistant is required.
Es necesario un ayudante.
Un assistant est nécessaire.

? 1 - 800 - 950 - 4782

A158093

Step 14

H146908

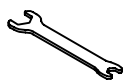

[1]

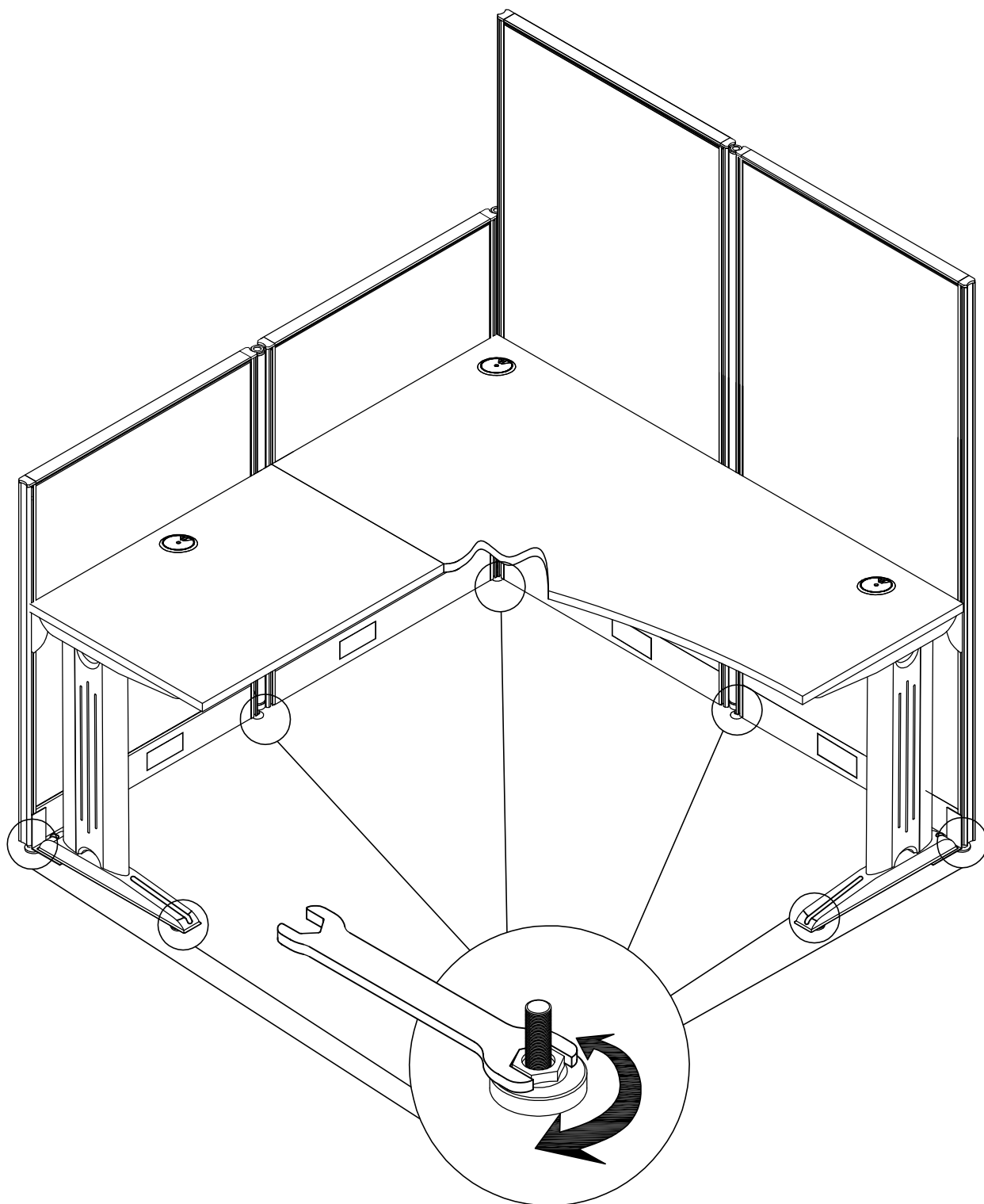

? 1 - 800 - 950 - 4782

A158093

Step 15

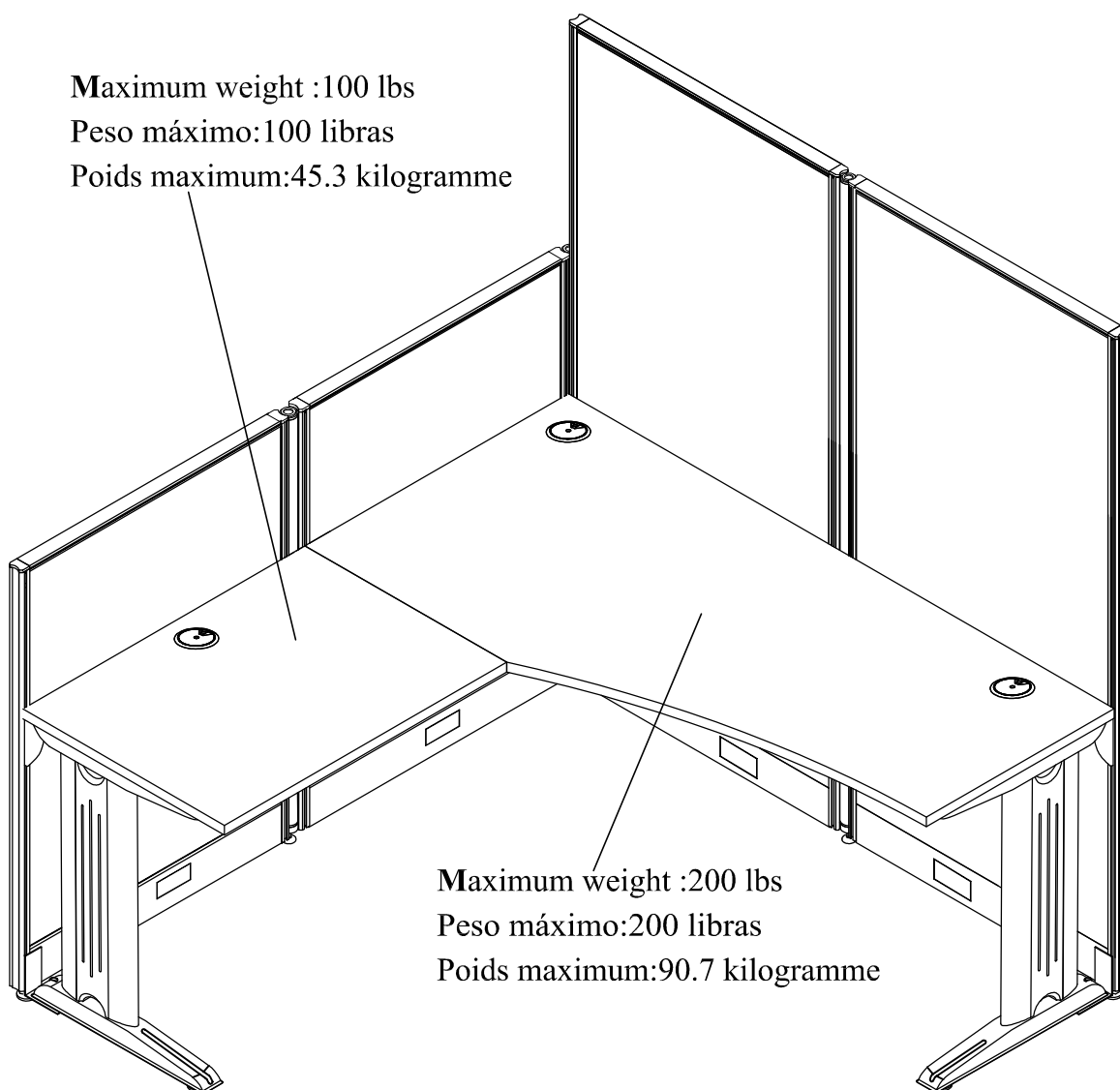

WARNING

Please assemble in final location, do not move after assembly.

Unit must be disassembled before relocating, do not move while assembled.

Moving the assembled unit could cause instability, product collapse and/or serious injury.

Por favor reúname en la posición final, no mueva la unidad despues de ensamblaje.

La unidad debe ser desmontada antes del traslado, no mueva la unidad ensamblada.

El movimiento de la unidad ensamblada podría causar la inestabilidad, el desplome del producto y/o heridas graves.

Veillez l'assembler dans l'endroit final, ne se déplacent pas après l'assemblage.

L'unité doit être démontée avant le déplacement, ne le déplacement pas tandis qu'elle est assemblée.

Le déplacement de l'unité assemblée peut causer l'instabilité, l'effondrement de produit et/ou les dommages sérieux.

Step 16

An assistant is required.
Es necesario un ayudante.
Un assistant est nécessaire.

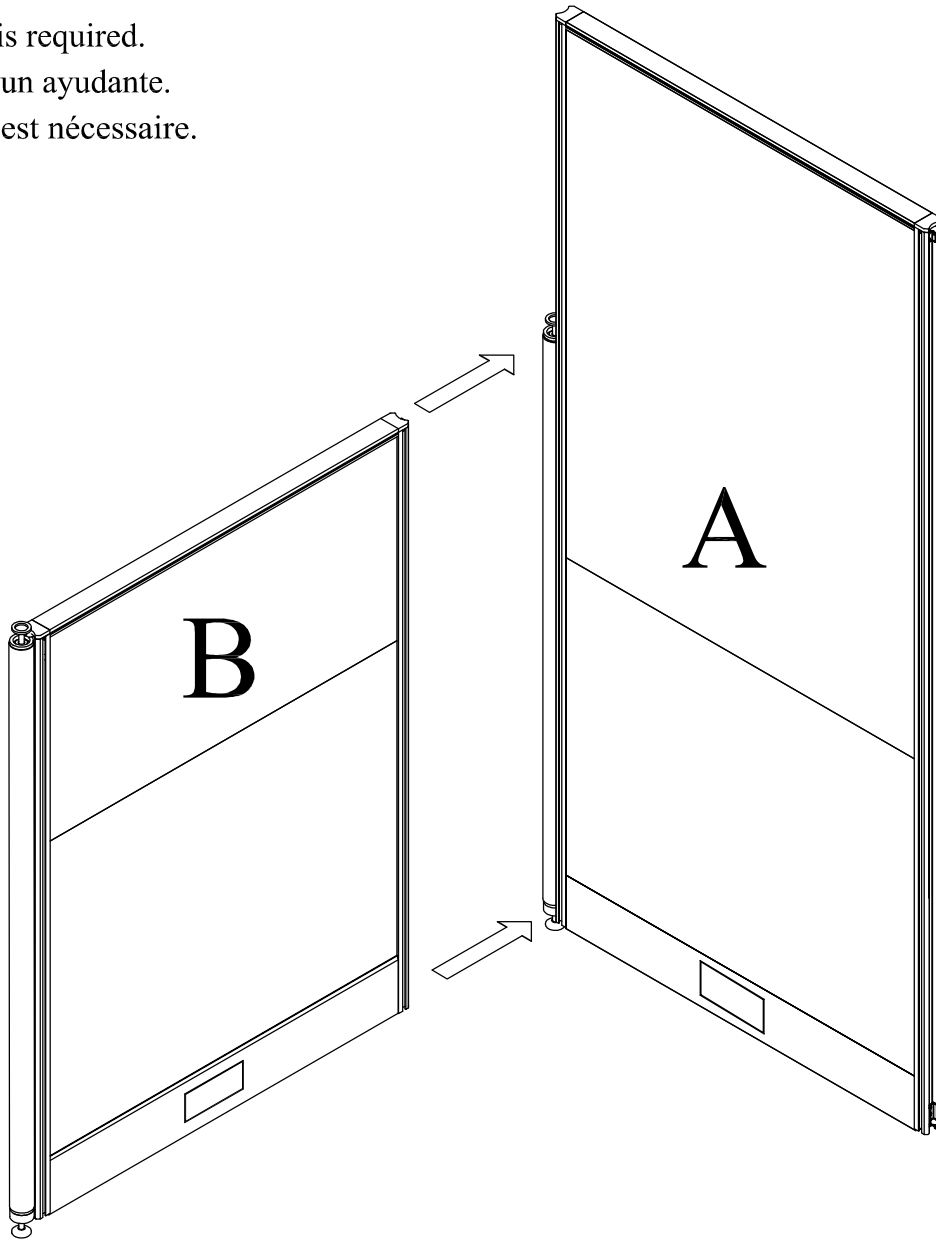

1 Loosen
aflojar
desserrez

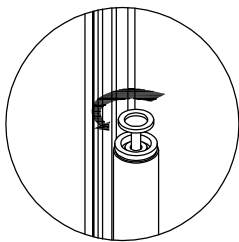

2 Assemble
ensamblar
réunissez

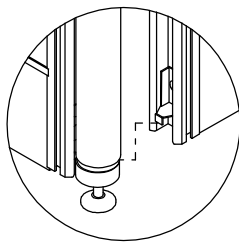

3 Assemble
ensamblar
réunissez

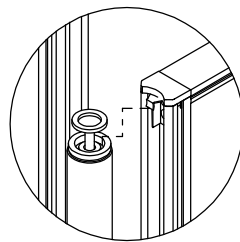

4 Tighten
Apretar
serrez

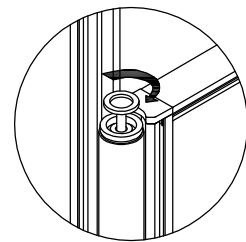

? 1 - 800 - 950 - 4782

A158093

Step 17

H153561



[1]

An assistant is required.
Es necesario un ayudante.
Un assistant est nécessaire.

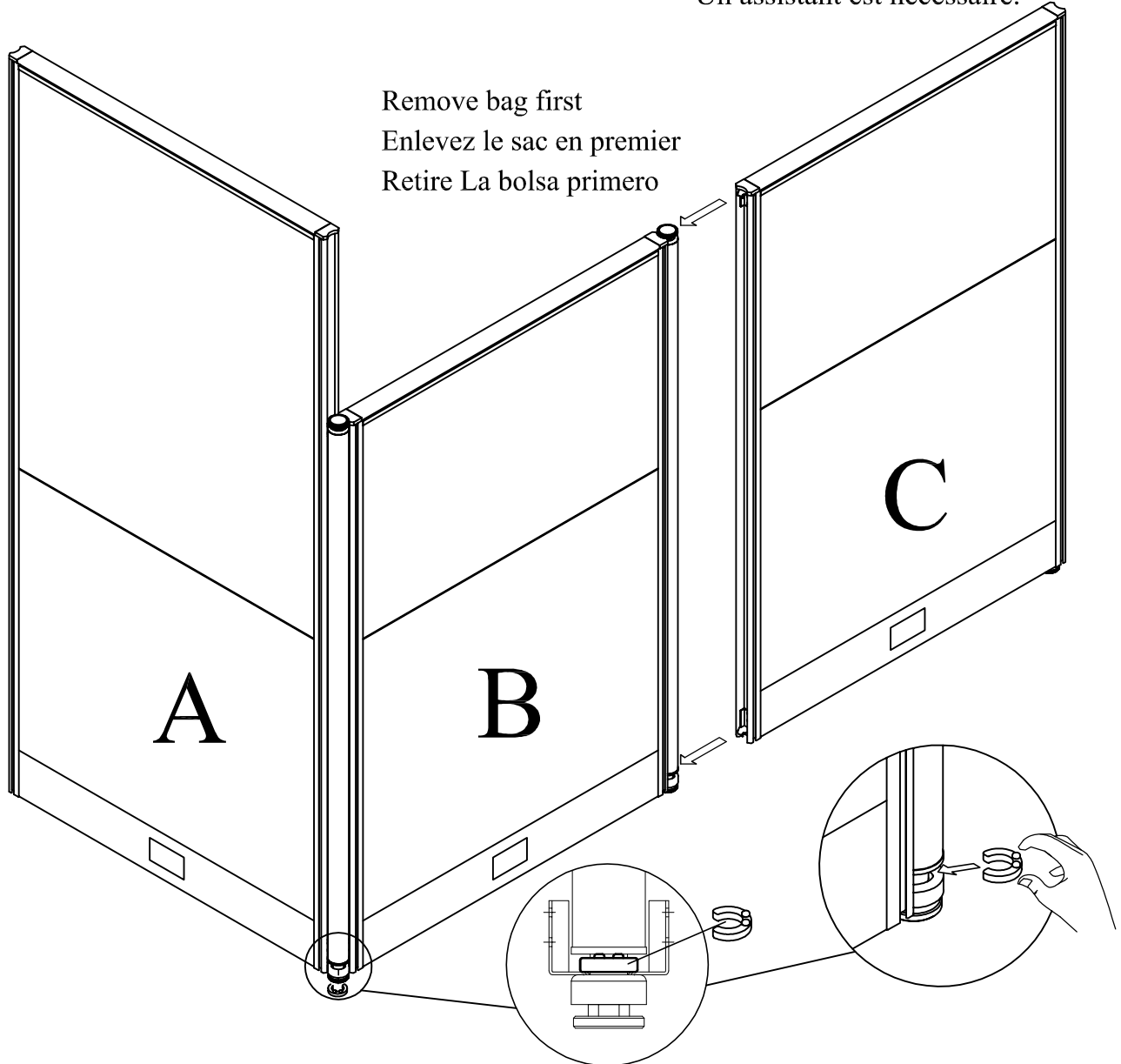

Remove bag first
Enlevez le sac en premier
Retire La bolsa primero

1 Loosen
aflojar
desserrez

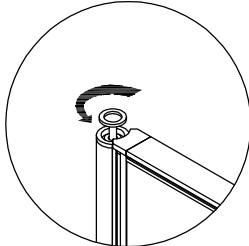

2 Assemble
ensamblar
réunissez

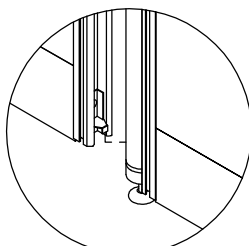

3 Assemble
ensamblar
réunissez

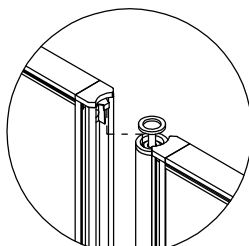

4 Tighten
Apretar
serrez

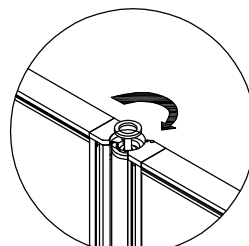

? 1 - 800 - 950 - 4782

A158093

Step 18

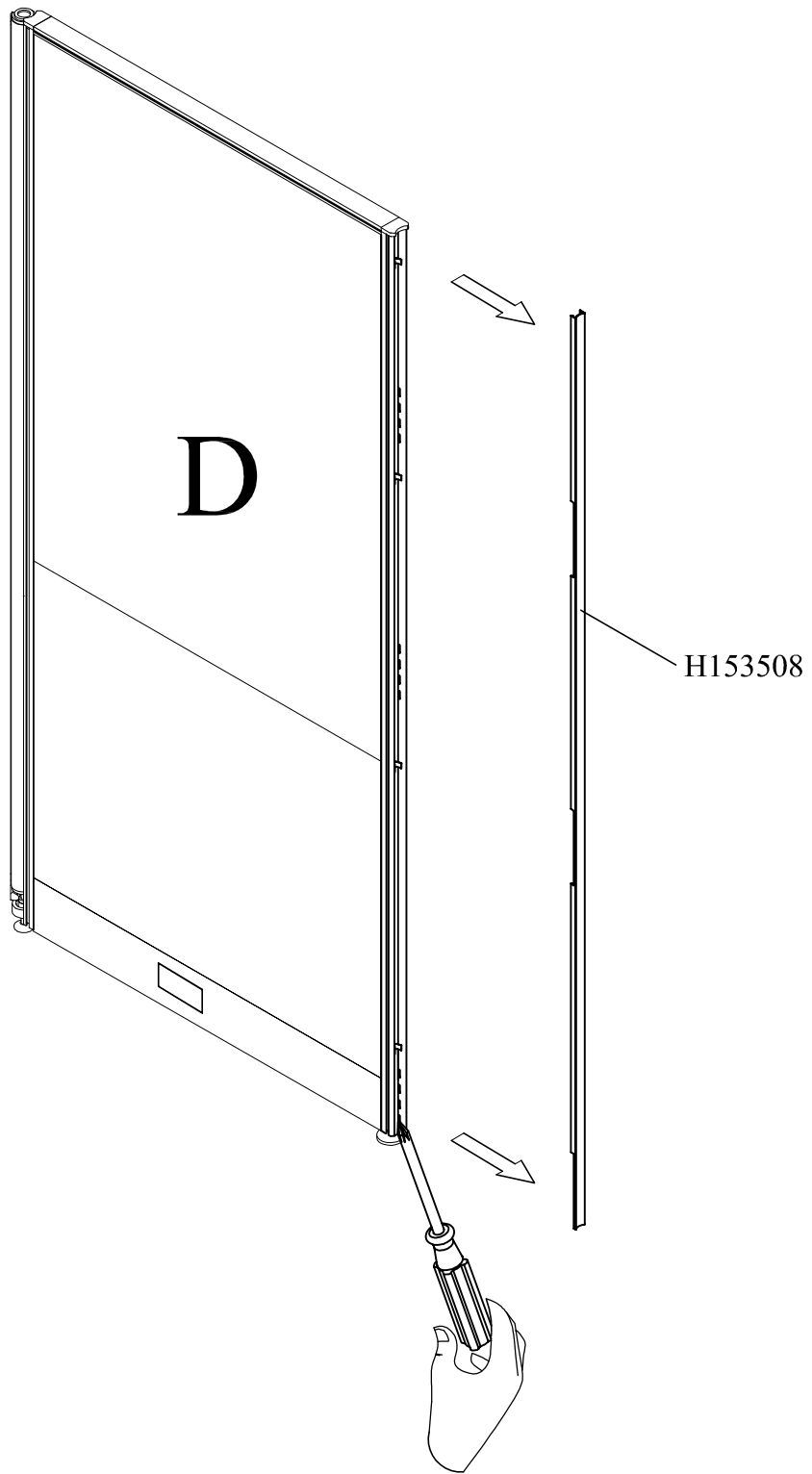

? 1 - 800 - 950 - 4782

A158093

Step 19

H153016  [1]

H153017  [1]

H153023  [4]

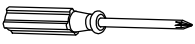
H146907  [1]

Open box of WC36496
Abra la caja WC36496
Ouvrir la boîte
WC36496

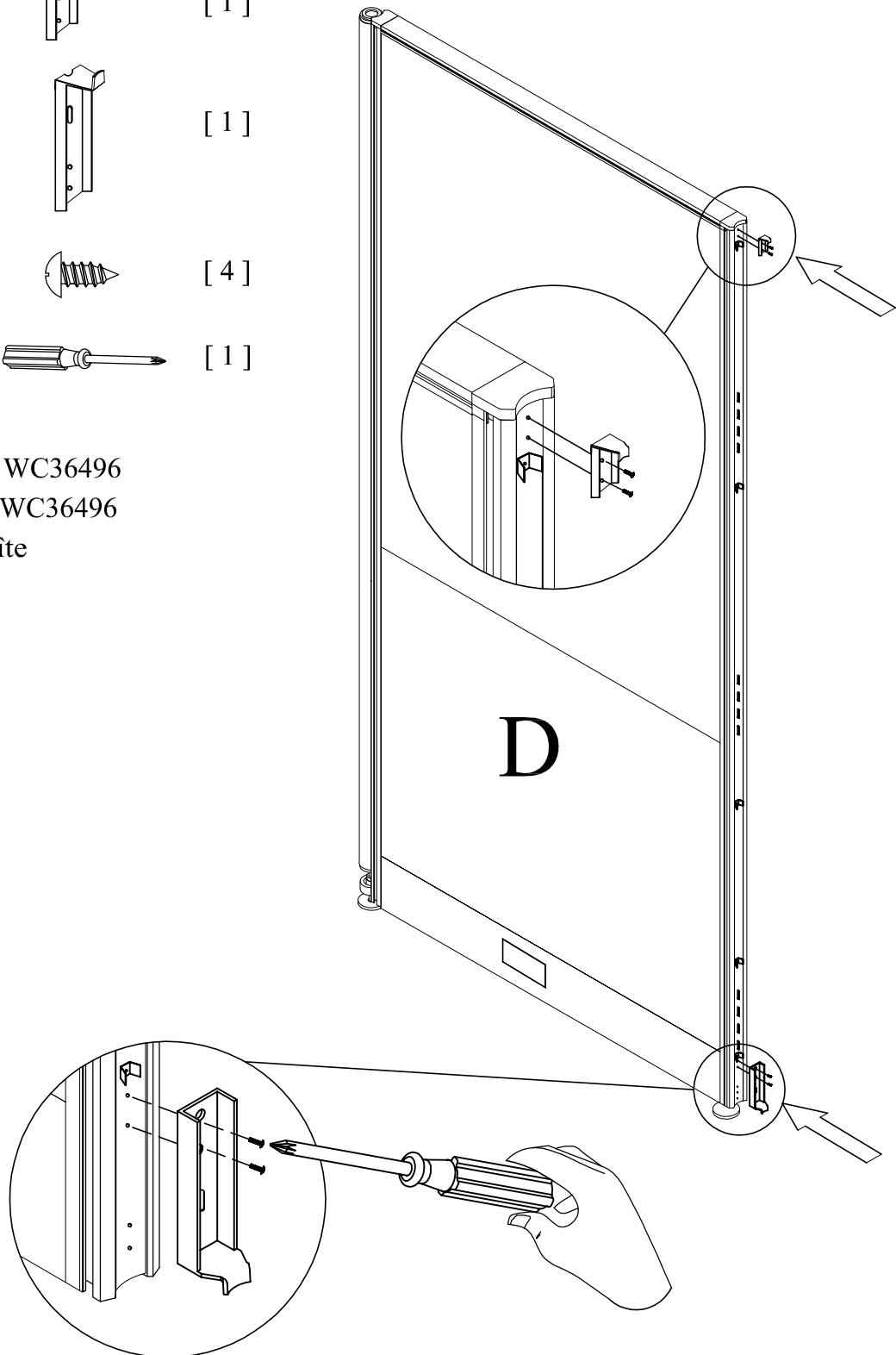

? 1 - 800 - 950 - 4782

A158093

Step 20

Discard carton and packaging material.
Descarte el material de cartón y embalaje.
Jeter le carton et le matériau d'emballage.

H153561



[1]

An assistant is required.
Es necesario un ayudante.
Un assistant est nécessaire.

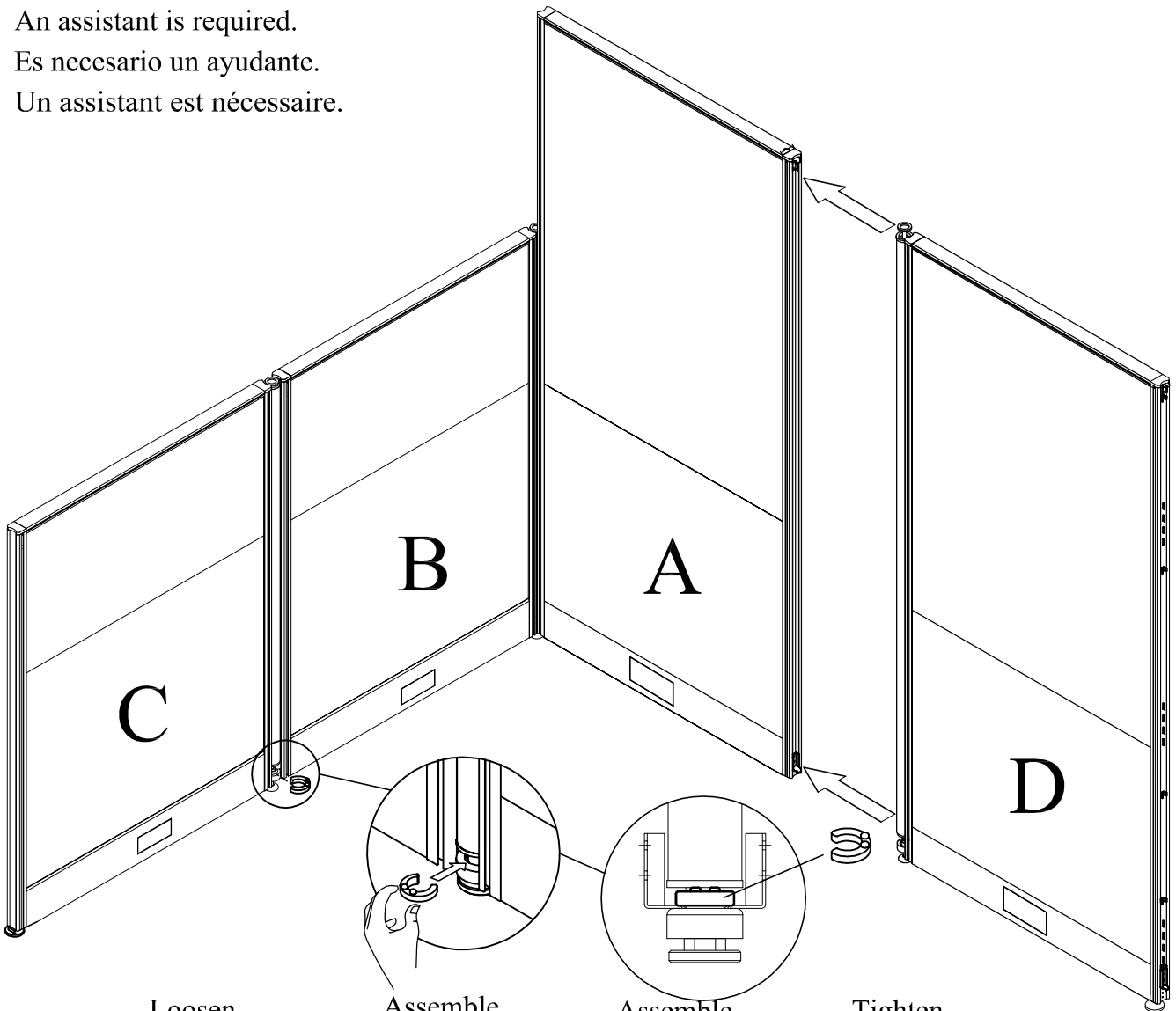

1 Loosen
aflojar
desserrez

2 Assemble
ensamblar
réunissez

3 Assemble
ensamblar
réunissez

4 Tighten
Apretar
serrez

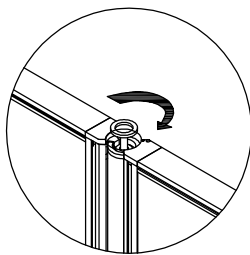
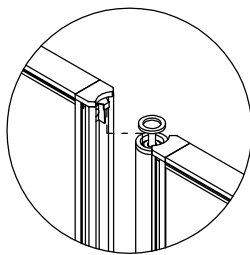
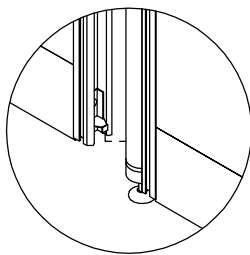
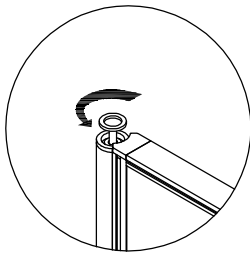

? 1 - 800 - 950 - 4782

A158093

Step 21

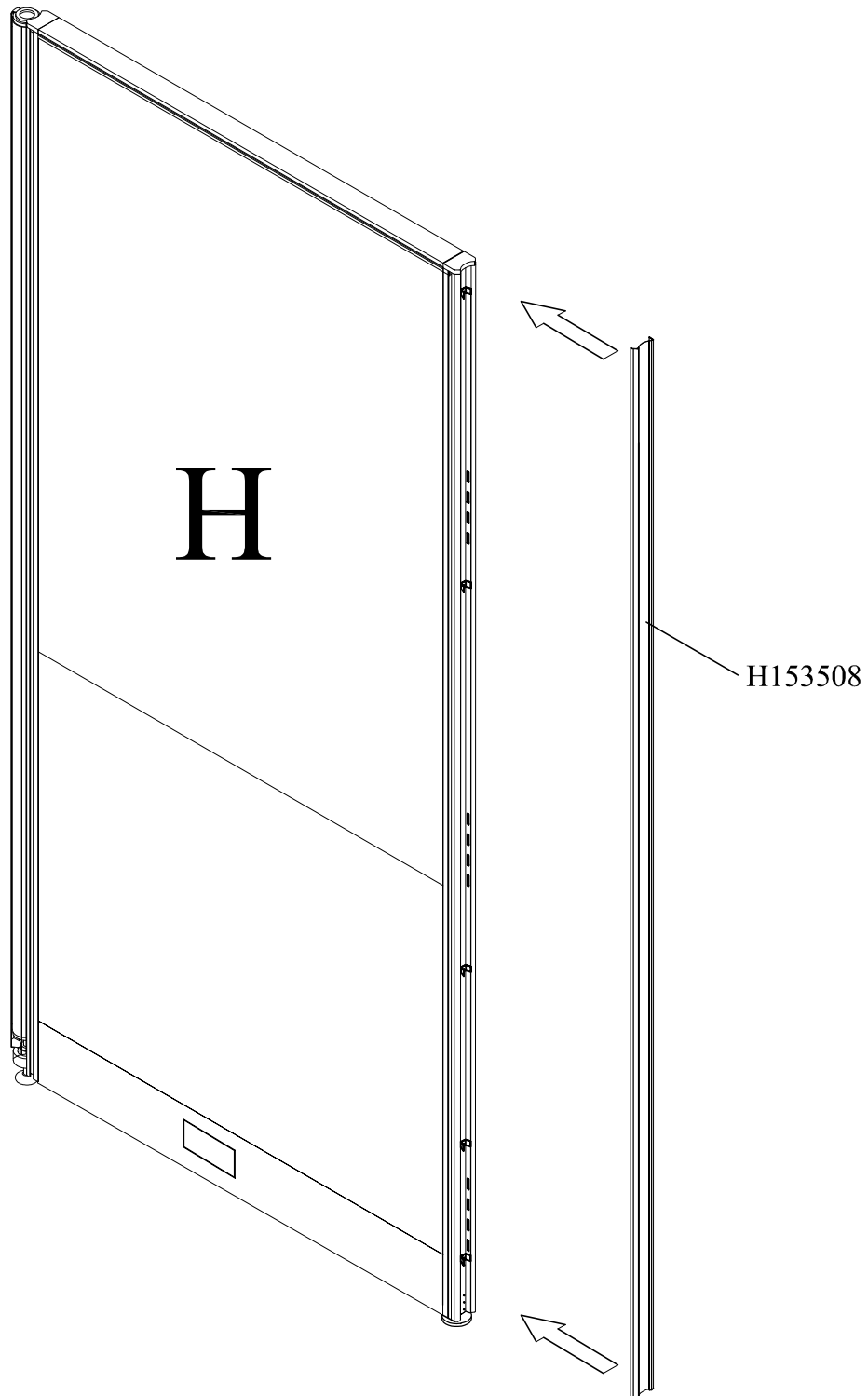

? 1 - 800 - 950 - 4782

A158093

Step 22

H153561



[1]

An assistant is required.
Es necesario un ayudante.
Un assistant est nécessaire.

Discard carton and packaging material.
Descarte el material de cartón y embalaje.
Jeter le carton et le matériau d'emballage.
Open box 2
Abra la caja 2
Ouvrir la boîte 2
Remove bag first
Enlevez le sac en premier
Retire La bolsa primero

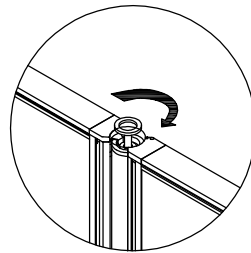
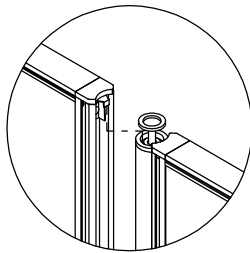
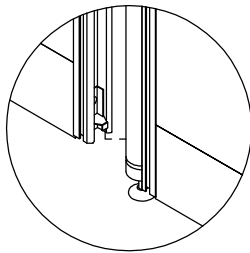
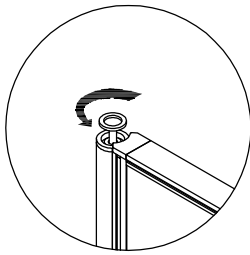
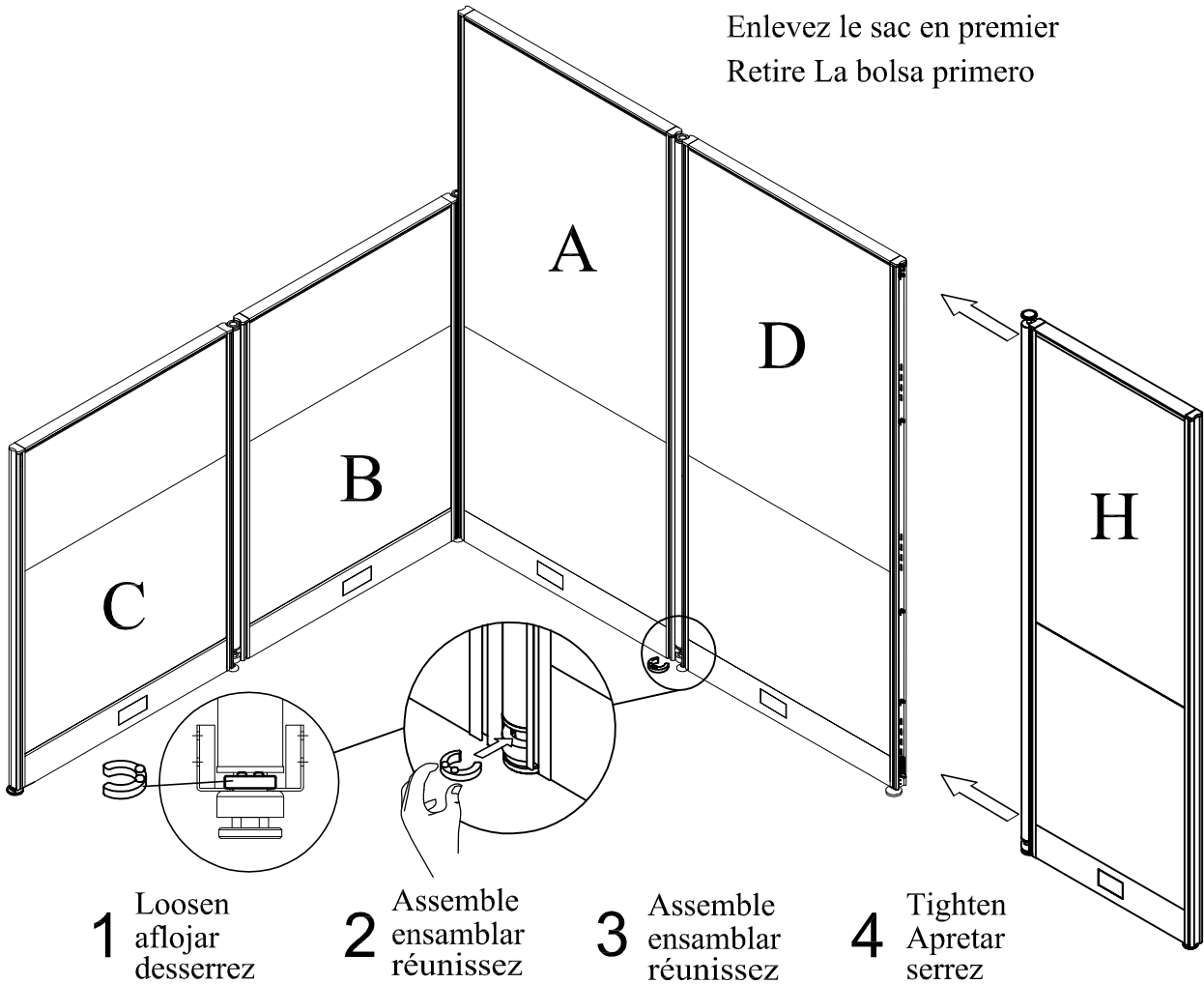

? 1 - 800 - 950 - 4782

A158093

Step 23

H153561



[1]

An assistant is required.

Es necesario un ayudante.

Un assistant est nécessaire.

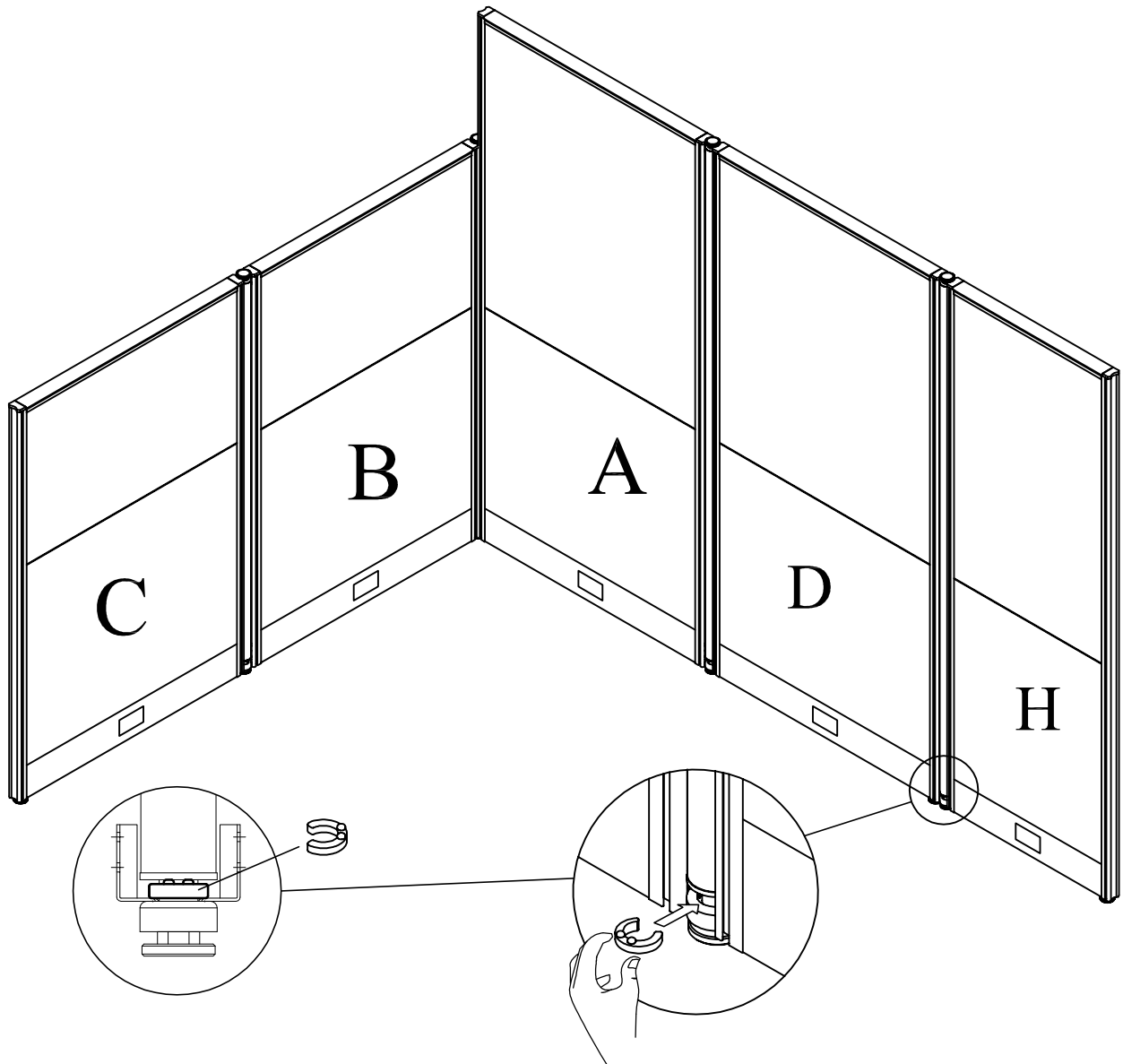

? 1 - 800 - 950 - 4782

A158093

Step 24

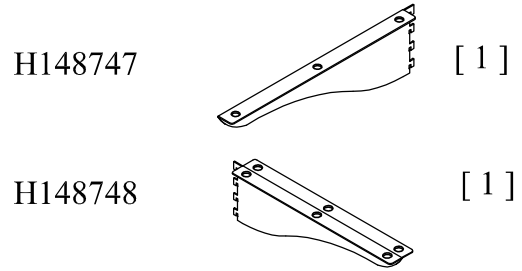
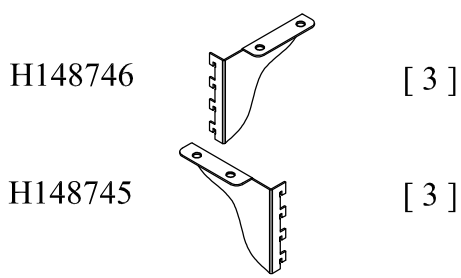

An assistant is required.
 Es necesario un ayudante.
 Un assistant est nécessaire.

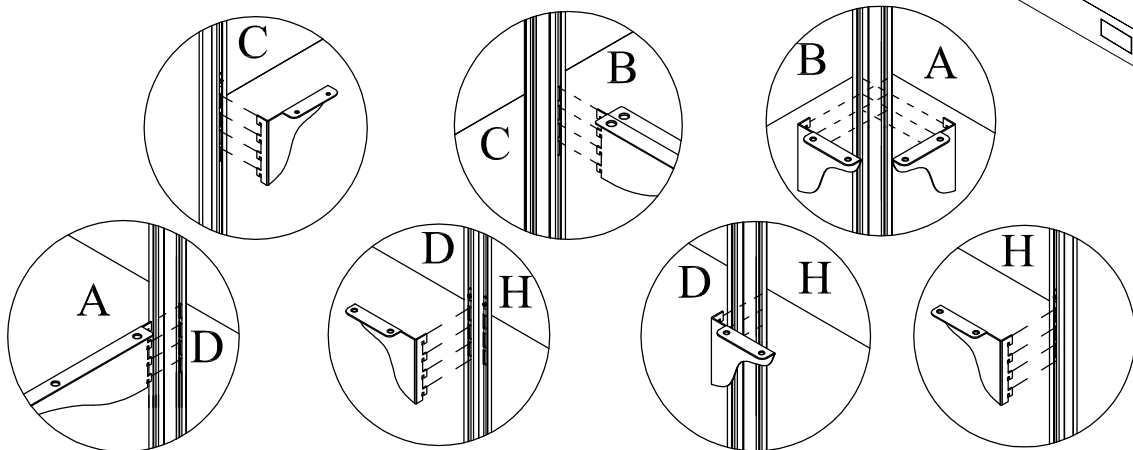
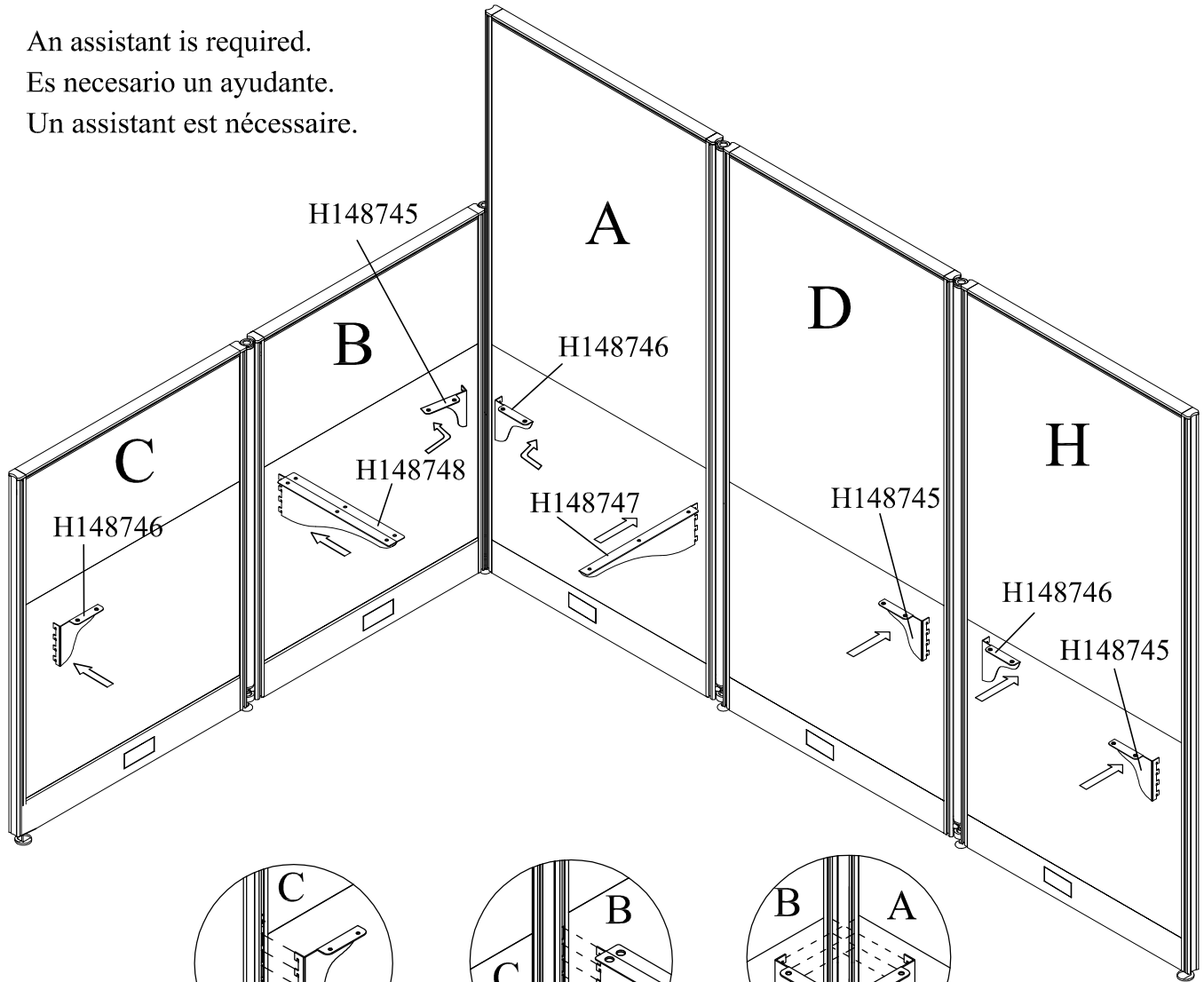



? 1 - 800 - 950 - 4782

A158093

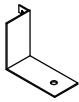
Step 25

H146899  [1]

H146898  [1]

H146905  [2]

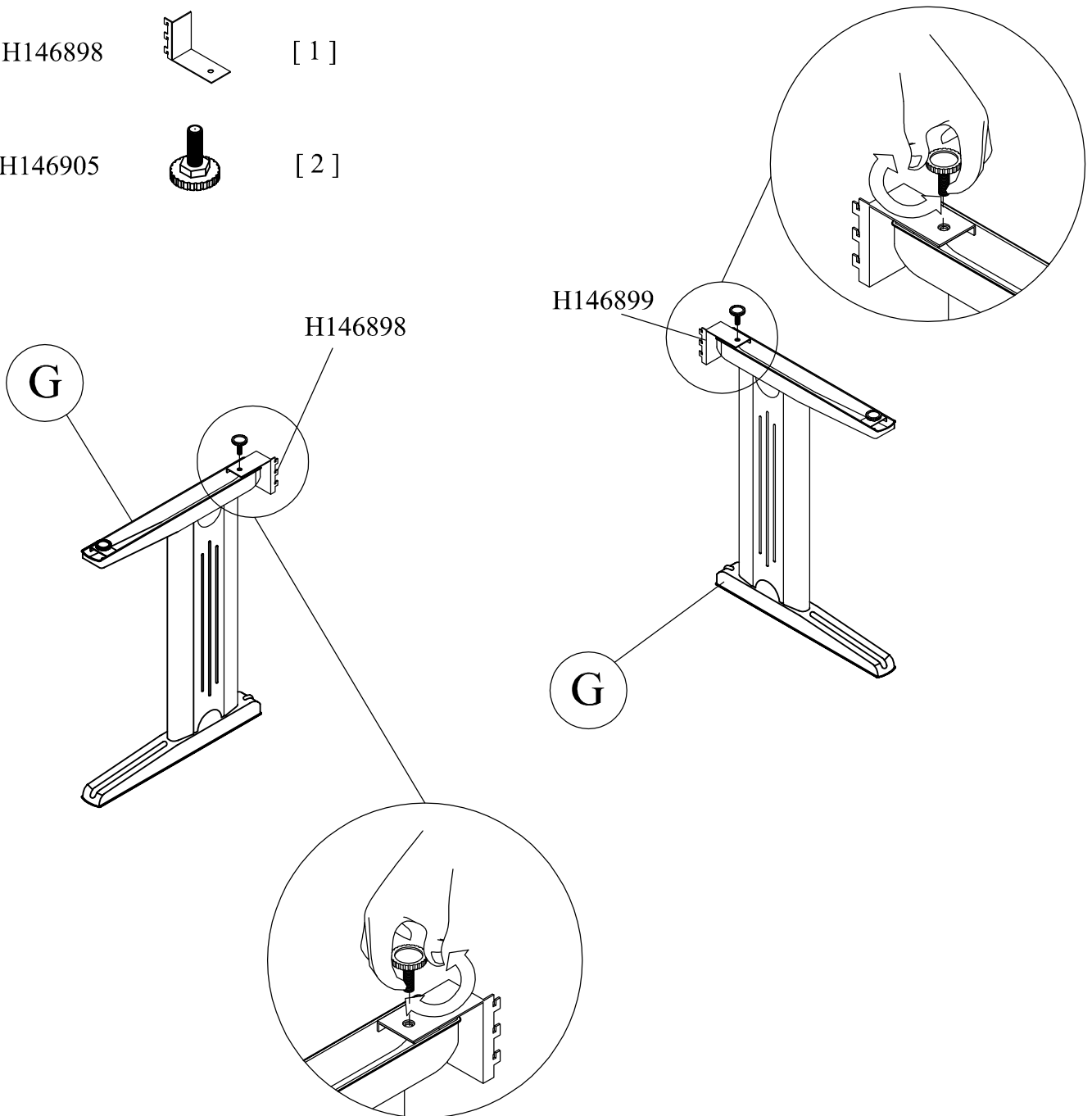

Step 26

Please loosen the screw first, place it just above the bracket, then tighten

Primero afloje el tornillo, colóquelo sobre el soporte, luego apriete

Veillez desserrer la vis d'abord, la placer juste au-dessus du croisillon, puis serrer

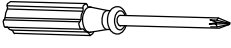

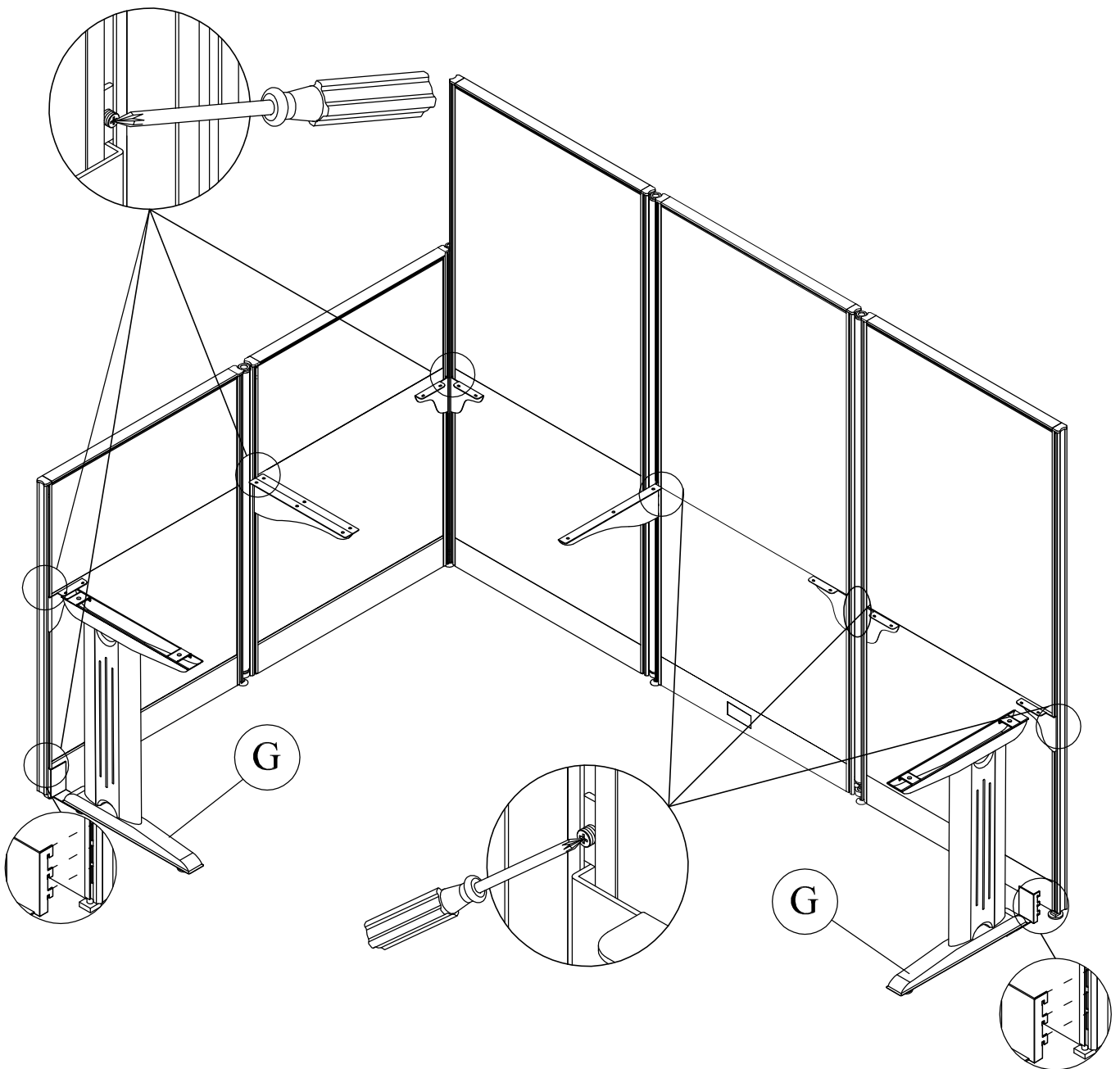



H146907  [1]

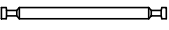

? 1 - 800 - 950 - 4782

A158093

Step 27

- | | | |
|---------|---|-------|
| H146904 |  | [3] |
| H146895 |  | [3] |
| H146907 |  | [1] |
| H146893 |  | [3] |
| H146892 |  | [3] |
| H27145 |  | [1] |
| H147242 |  | [2] |

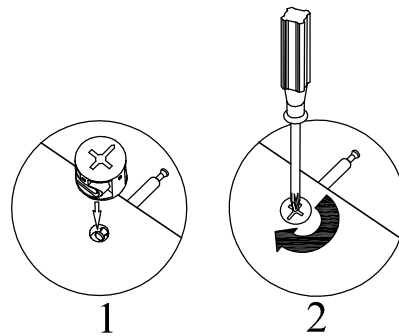
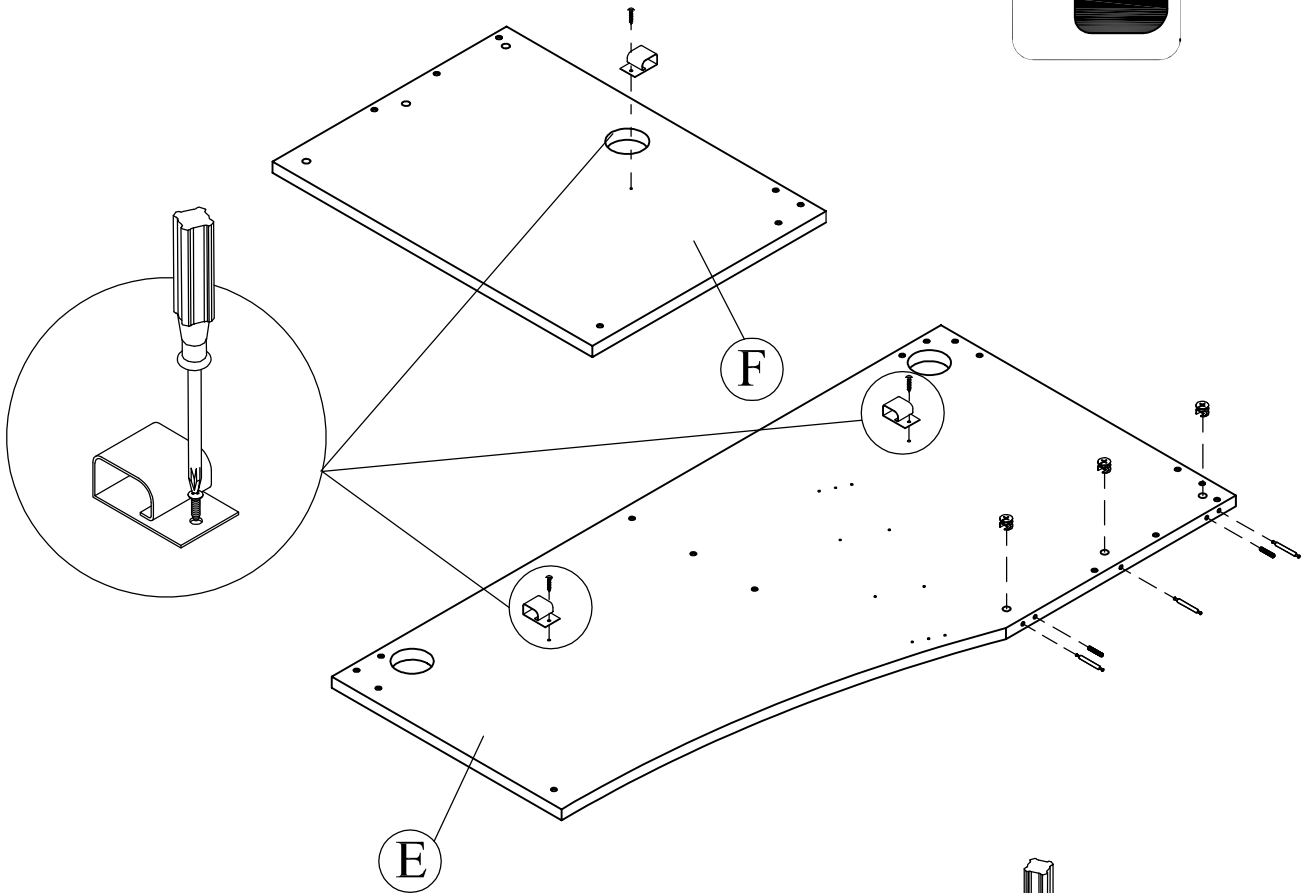
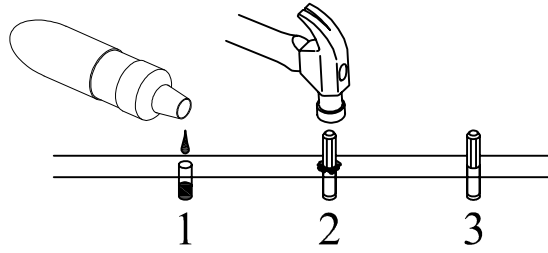

An assistant is required.
 Es necesario un ayudante.
 Un assistant est nécessaire.

? 1 - 800 - 950 - 4782

A158093

Step 28

An assistant is required.
Es necesario un ayudante.
Un assistant est nécessaire.

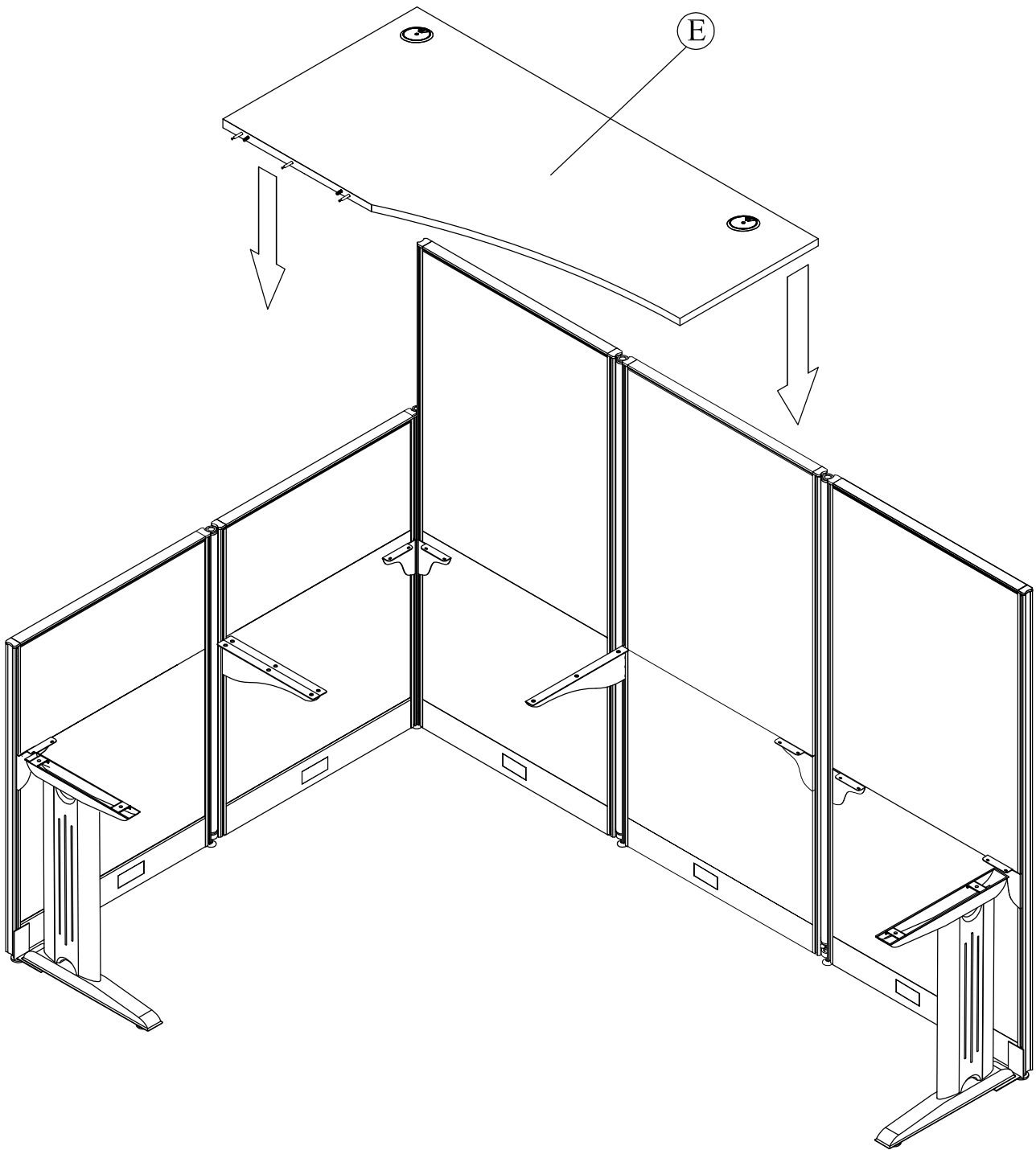

? 1 - 800 - 950 - 4782

A158093

Step 29

An assistant is required.
Es necesario un ayudante.
Un assistant est nécessaire.

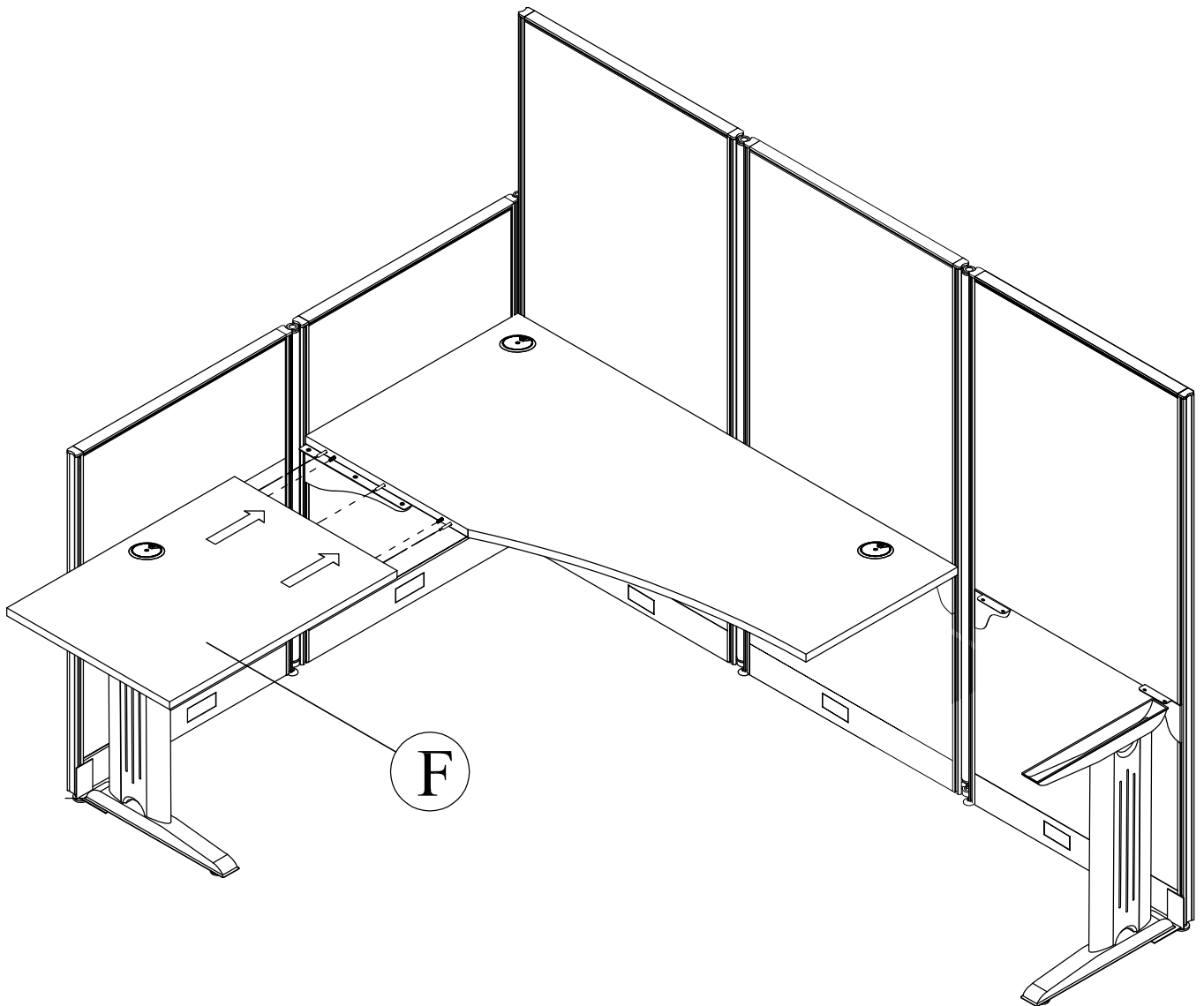

Step 30

H146892  [3]

An assistant is required.
Es necesario un ayudante.

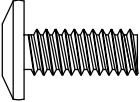
H148756  [2]

Un assistant est nécessaire.

H146907  [1]

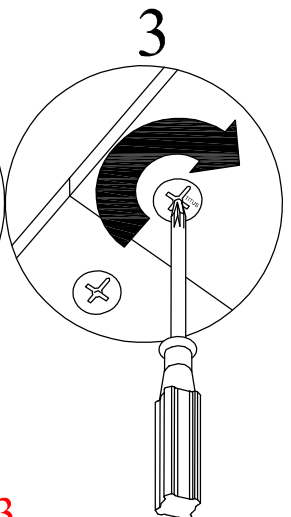
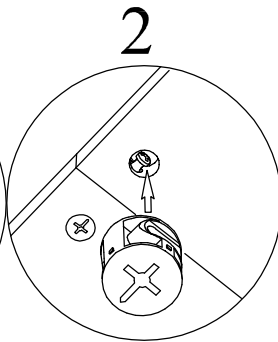
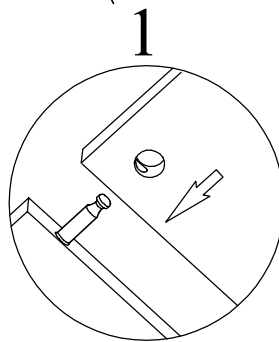
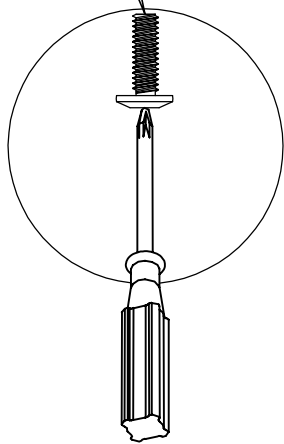
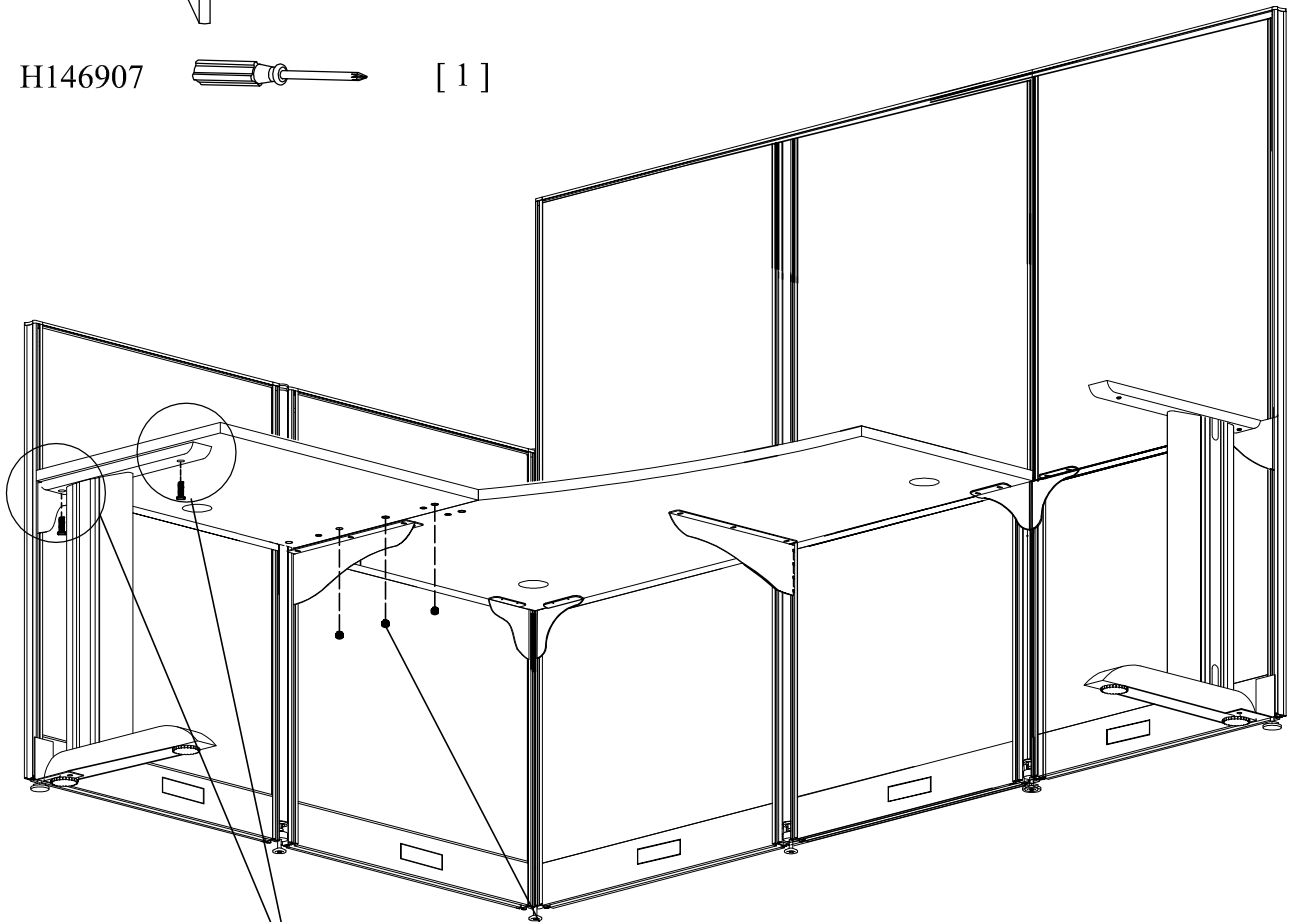

? 1 - 800 - 950 - 4782

A158093

Step 31

H148749

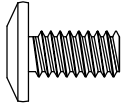

[17]

H146907



[1]

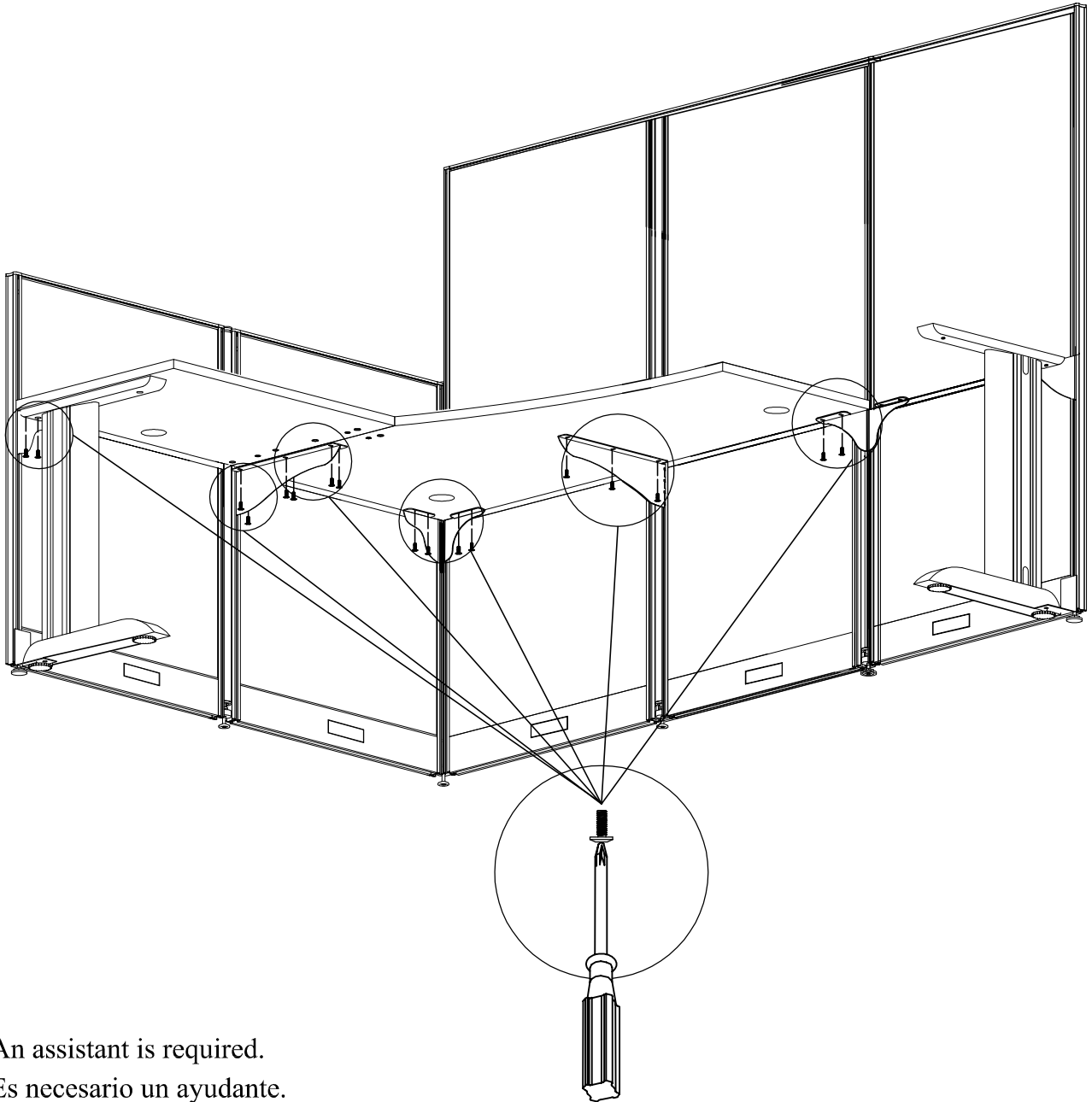

An assistant is required.
Es necesario un ayudante.
Un assistant est nécessaire.

? 1 - 800 - 950 - 4782

A158093

Step 32

H153020

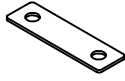

[2]

H148756

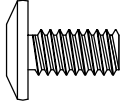

[2]

H146907



[1]

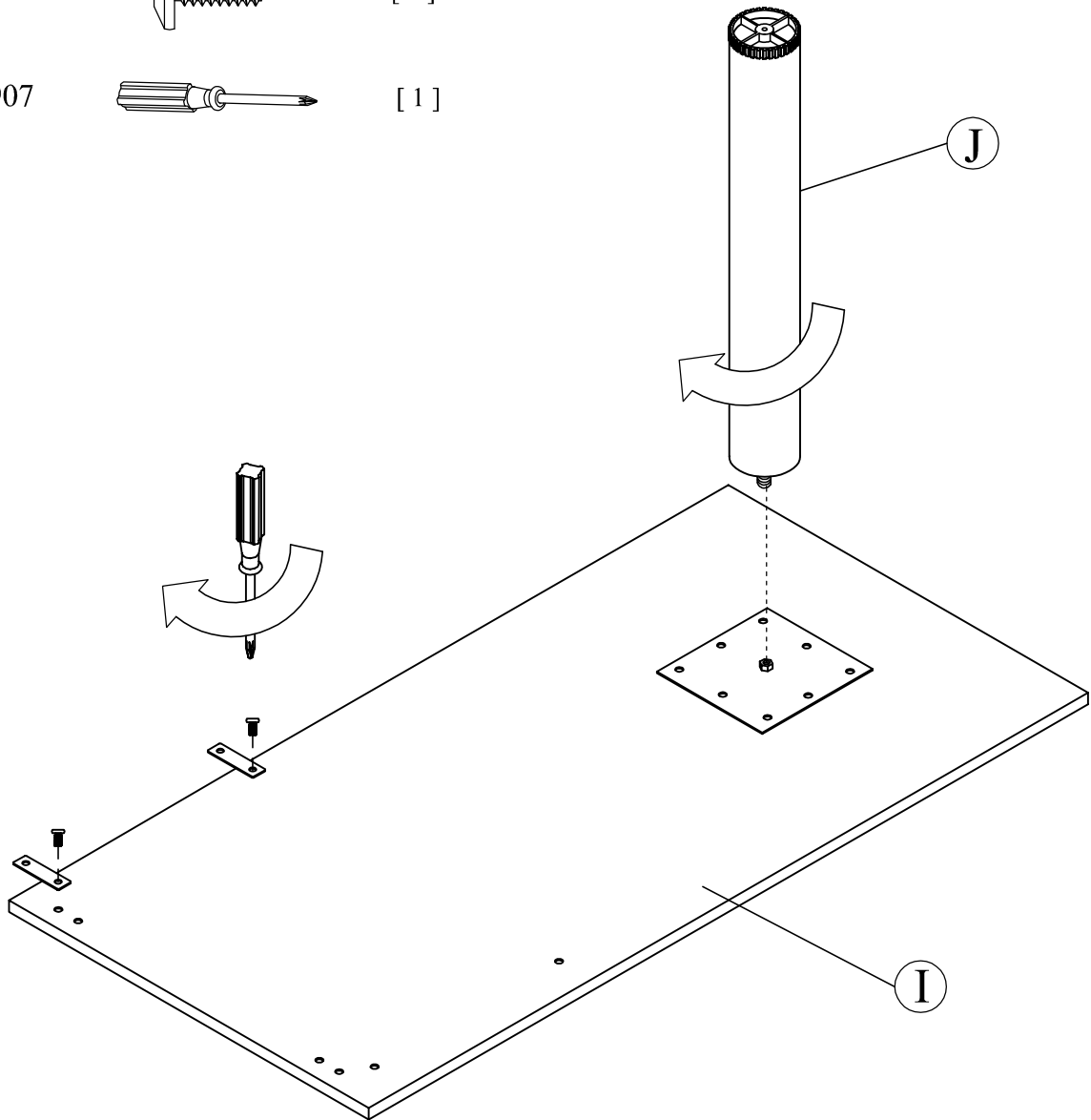

? 1 - 800 - 950 - 4782

A158093

Step 33

An assistant is required.
Es necesario un ayudante.
Un assistant est nécessaire.

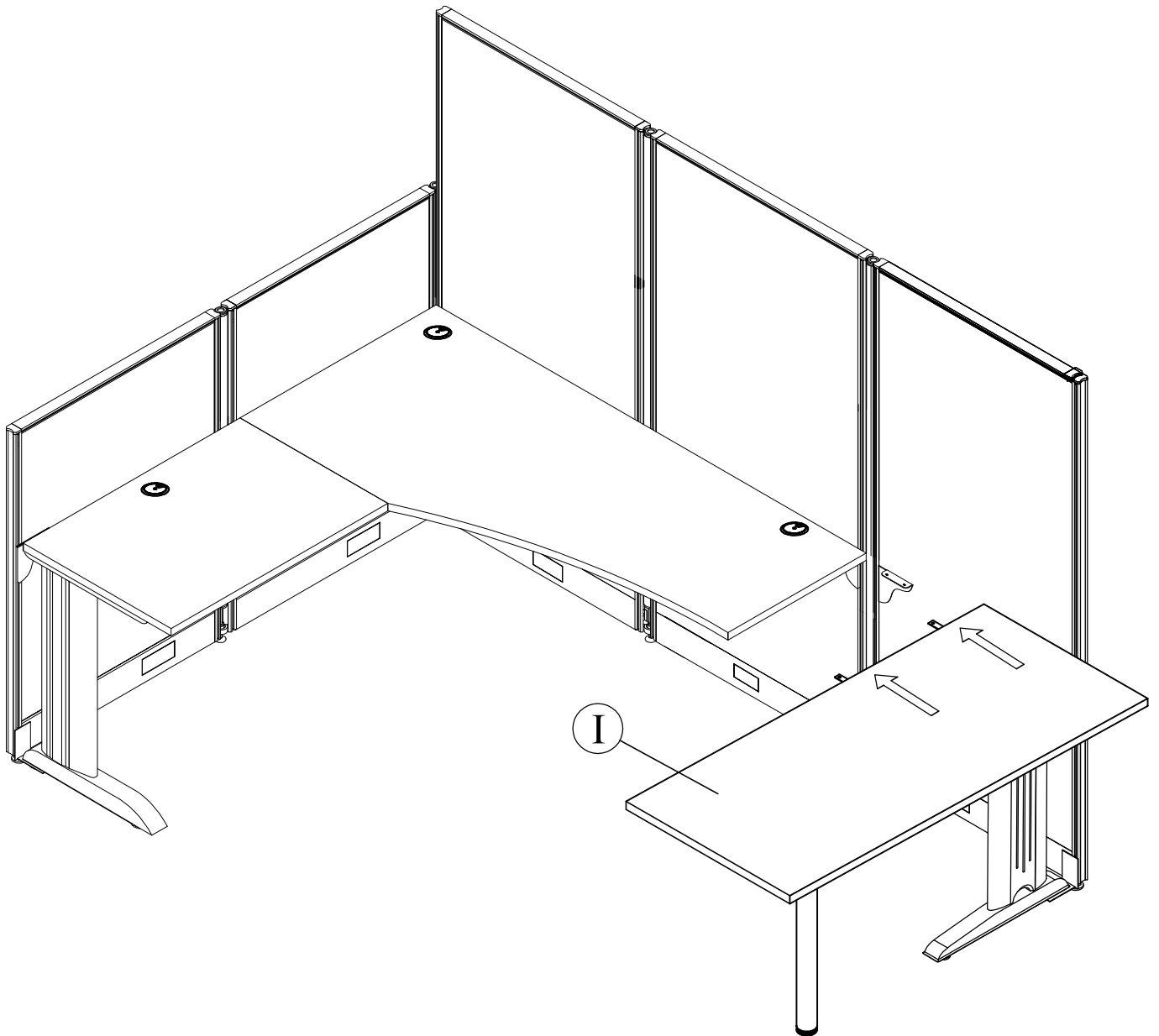

? 1 - 800 - 950 - 4782

A158093

Step 34

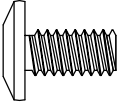
H148749  [4]

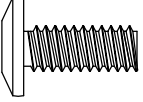
H148756  [4]

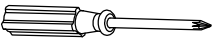
H146907  [1]

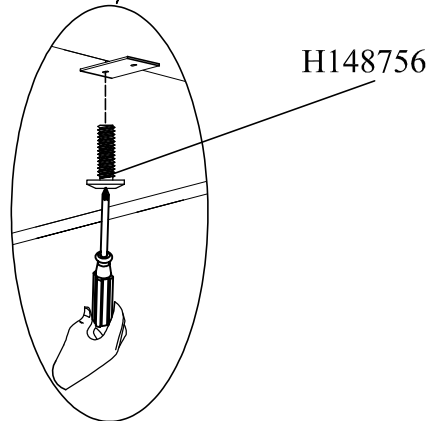
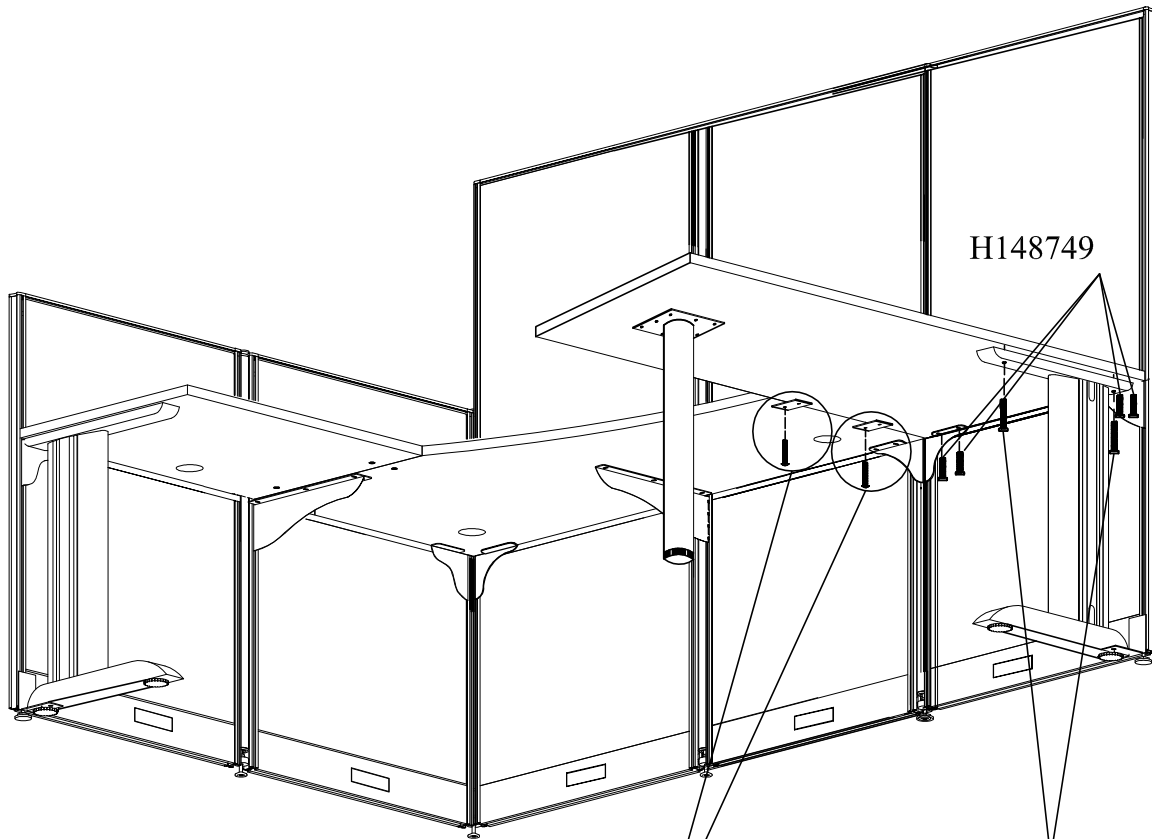

An assistant is required.
Es necesario un ayudante.
Un assistant est nécessaire.

? 1 - 800 - 950 - 4782

A158093

Step 35

H146908

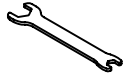

[1]

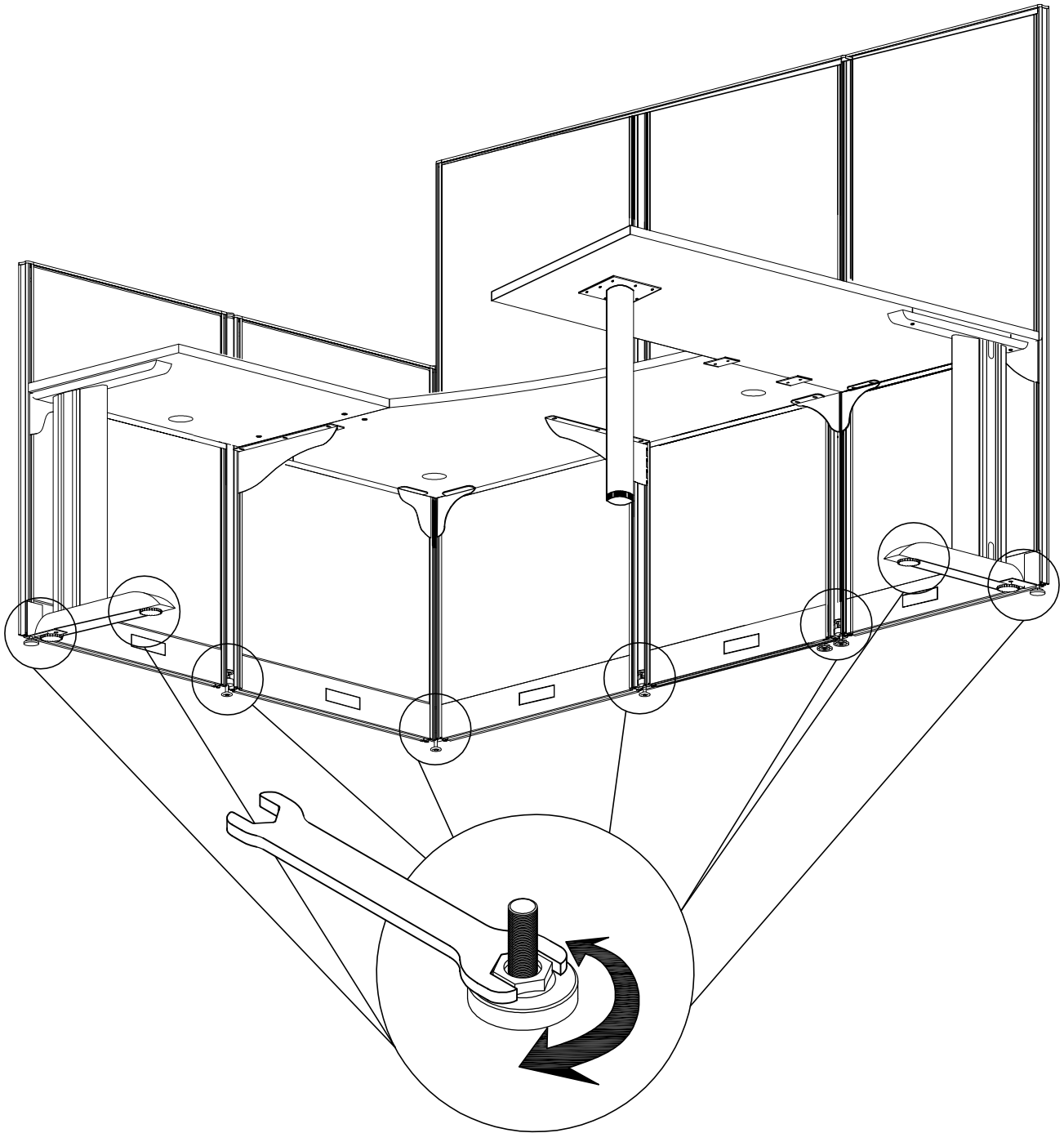

? 1 - 800 - 950 - 4782

A158093

Step 36

Maximum weight :100 lbs
Peso máximo:100 libras
Poids maximum:45.3 kilogramme

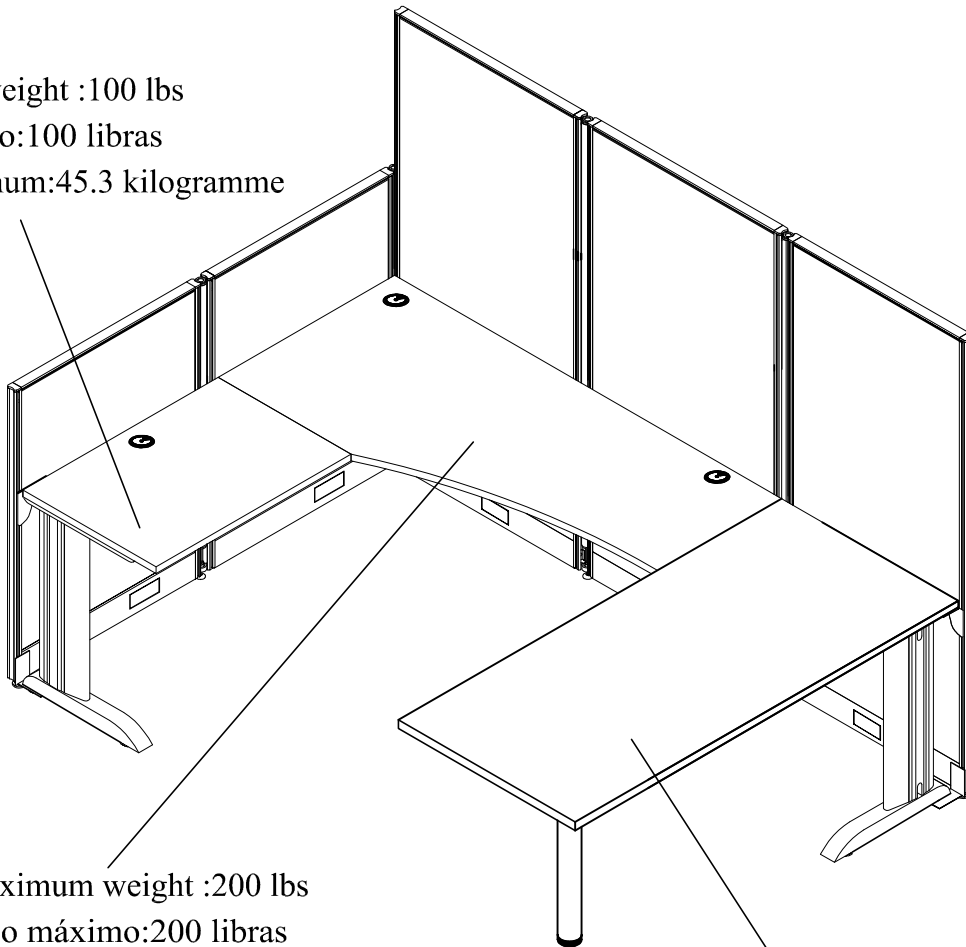

Maximum weight :200 lbs
Peso máximo:200 libras
Poids maximum:90.7 kilogramme

Maximum weight :200 lbs
Peso máximo:200 libras
Poids maximum:90.7 kilogramme

WARNING

Please assemble in final location, do not move after assembly.
Unit must be disassembled before relocating, do not move while assembled.
Moving the assembled unit could cause instability, product collapse and/or serious injury.

Por favor reúname en la posición final, no mueva la unidad despues de ensamblaje.
La unidad debe ser desmontada antes del traslado, no mueva la unidad ensamblada. El movimiento de la unidad ensamblada podría causar la inestabilidad, el desplome del producto y/o heridas graves.

Veillez l'assembler dans l'endroit final, ne se déplacent pas après l'assemblage. L'unité doit être démontée avant le déplacement, ne le déplacement pas tandis qu'elle est assemblée. Le déplacement de l'unité assemblée peut causer l'instabilité, l'effondrement de produit et/ou les dommages sérieux.

? 1 - 800 - 950 - 4782

A158093